

**Secret History
of the
Thulegesellschaft**



LUIS FELIPE MOYANO
"NIMROD de ROSARIO"

Secret History of the Thulegesellschaft



by

Luis Felipe Moyano
"NIMROD de ROSARIO"

TRANSLATED INTO ENGLISH

CAINITE PUBLISHING COMPANY

2023

Copyright © 2023, by
Cainite Publishing Company.

Originally published in Argentina as
Historia secreta de la Thulegesellschaft.

All rights reserved.

No part of this publication may be reproduced, stored in a retrieval system, stored in a database and/or published in any form or by any means, electronic, mechanical, photocopying, recording or otherwise, without the prior written permission of the publisher.

Note from the Translator

Contained herein is a literal translation from the author's original manuscript. No part of this translation was done in an automatic manner or put through a translating machine, but manually performed, word by word, with every intention to preserve the exactitude of the original language and the incomparable literary qualities of the author and his work, leaving no part of this translation to chance. Each word and phrase has been rigorously proofread for accuracy and grammatical and historical correctness, often adapting the names of places and personages to their English-language equivalent. No part of this work has been altered during the process, with every effort made to preserve the syntax and sentence structure of the original and the intention to allow the author's words to speak for themselves, without interpretation or editorialization. Footnotes have been added to clarify and explain either foreign, archaic, or unfamiliar terms and phrases, to increase readability.

Table of Contents

Prologue.....	i
---------------	---

First Dissertation

Secret Societies and the Thulegesellschaft

First Part	1
Second Part	12

Second Dissertation

Secret History of the Thulegesellschaft

Introduction.....	24
Princess Papan's Stone Mirror	27
Dr. John Dee and the Stone Transducers	38
Steganography of Trithemius, a Hyperborean Work.....	43
Elementary Notions on the Hyperborean Wisdom	54
John Dee Seventeen Years Later	72
The Legend of Nimrod "the Defeated"	80
The Thule Project of John Dee	125
John Dee in Bohemia.....	144
The Hyperborean Initiation.....	158
Epilogue to the Adventure of Dr. John Dee	175
Foundation of the SD2 Order.....	188
Historical Schema of the SD2.....	260
Introduction to the 22 Strategy	310
Tantra Yoga.....	358
The Family Test	371
Ritual of the Five Defiances	391
Fundamentals of Noological Runics	428
Complementary Concepts.....	457

Fourth Dissertation

Treatise on the **⚡** Psychosocial Strategy

Section I.....	469
Section II.....	475
Section III.....	476
Section IV	483
Section V.....	489
Section VI	509
Section VII.....	523

The Mystique of the Runes

Runic Alphabets.....	534
----------------------	-----

Author's Disclaimer

Reader, think that in reading this book you set foot on a land seldom trodden by others. It is my duty to warn you that the eye of Jehovah Satan will, from now on, be set upon you. You will be accursed to Him and He will try to destroy you. You will have to flee! But where, if He is all around you?

You will call out for help to our serpent-God Khristos Lú-cifer, but He sleeps in order to awaken at the end of the Kaly Yuga. Only the ancient goddess Lillith watches over this black night of infernal darkness. You must seek Her! But bear in mind that She will demand from you the eternal and icy love of the Hyperborean Siddhas.

Reader, are you capable of loving Lillith? If you do not feel the eternal love, always present in the "Blood Memory" of the Minne: if you are not capable of transmuting and eternalizing yourself as a Hyperborean Siddha: then, for your own good, it is the author's will that you do not read this book.

Prologue



I have gathered in this third book the contents of three of the four dissertations that Uncle Kurt made to me, on the most secret subjects that can be conceived. It is necessary, however, that I expose them here because, without sharing this knowledge with the reader, it would be useless to continue later with the history of Belicena Villca, which is my own history. Were I to proceed otherwise, the subsequent events would be totally incomprehensible.

We must remember that my trip to Catamarca was for the purpose of obtaining precise information about the **⚡** of the German Third Reich. I was then believing that this data would help me to solve the mystery of the Druids, whose presence in Salta to liquidate Belicena, was for me, who had seen the bejeweled rope, an undeniable reality. But upon encountering Uncle Kurt, I was discovering that my unusual adventure was part of a greater reality, which he was also forming a part of. Thus, guided by his entertaining story, I was following the steps that led him to the highest level of German leadership and also to its most profound secrets.

When reaching this part of the story Uncle Kurt unfolded, as has been said, his explanations into four dissertations that would correspond, according to him, to the principal lines of thought that Konrad Tarstein developed in the old house in Berlin, as knowledge preliminary to the Hyperborean initiation.

According to Uncle Kurt, in order to *be in a position to comprehend* the internal constitution of the **⚡**, its origins and esoteric objectives, one should *first* possess a formidable volume of information. This condition is indispensable, since the **⚡** is only the exterior, visible appendage of an invisible organic force that starts as such, many centuries ago, but the hidden genesis of which must be sought millions of years in the past.

This “invisible organic force” is a Secret Society, or better said, it is a succession of three “societies” of which only the first of them can be considered “Secret.” We will briefly explain this concept. The conception of an **⚡** Black Order has emanated from the Thulegesellschaft. The Thulegesellschaft was formed by men of the Germanenorden. And some men of

the Germanenorden were coming from the Sapiens Donabitur Astris (SDA).

But it is not only a question of highlighting some men or emphasizing some superficial linkage between Secret Societies. That would be a mediocre criterion and, of course, totally wrong. The “truth,” from which all analyses must start, is the following: *there is a Hyperborean Wisdom that has been transferred from the past to the present.* This is a “truth” that can be verified by simply observing its historical consequences: the **⚡** and the Third Reich. Because the line that Uncle Kurt highlights, the **⚡**, the Thulegesellschaft, the Germanenorden and the SDA, is really that by which terrible ancient secrets arrived to the present.

We have already said that it is impossible to approach the interpretation of the **⚡** without possessing important preliminary information. Let us now see how to access it.

Uncle Kurt’s first dissertation, I have divided into two parts, which constitute the first two chapters of this third book. It is a comparative study of the Thulegesellschaft and the Secret Societies of the Synarchy. Following that is the secret history of the Thulegesellschaft which, because of its length, I have had to divide into chapters. This is the second dissertation. Finally, I have divided into two chapters the brief but highly esoteric third dissertation, where the secret history of Heinrich Himmler and the **⚡** is recounted.

I must say that I have decided to add the Fourth Dissertation, since it is a printout of the *Treatise on the **⚡** Psychosocial Strategy*, on which Uncle Kurt only made a few brief reflections. But I will return to this subject in the respective prologue.

All that I have transcribed in this third book is, like everything before it, an almost verbatim reproduction of Uncle Kurt’s words and I have even repeated his brief citations to some fairly standard literary sources. This fidelity has led me to somewhat sacrifice the literary form and to abuse the declensions of the pronouns. I have also changed, after the second chapter, the grammatical person, going many times from the first singular to the third plural. These stylistic faults have a simple explanation: Uncle Kurt was demonstrating a superlative respect for the memory of Konrad Tarstein, who was his instructor in the Thulegesellschaft and, for such a reason, when he was approaching a subject, the knowledge of which

he had obtained through his intermediary, he was automatically speaking in the plural. He used to say in those cases "... *We know* that the Kassites were Hyperboreans and ... etc.," utilizing the plural "*we know*" in some allusion to Konrad Tarstein. On the other hand, he was changing the grammatical person when saying, for example, ... "*It is* understood, then, that the Kassite priests were also called Cainites ... etc."

Instead of repairing these grave stylistic faults by modifying the original narration, I have preferred to preserve the freshness of that marvelous oral prose that Uncle Kurt was displaying in Santa María de Catamarca. In this way, perhaps the suggestive implications that possess his sentences and propositions, loaded with metaphysical meaning and *conformed* according to *that manner of thinking* that he was calling Hyperborean Wisdom, can be better grasped.

It is a long road that I propose to travel in this third book, but it is part of that which I myself transited when I left for Catamarca in order to find out the truth about the ⚡ and the Druids. And, I must tell you now, it was thanks to the knowledge obtained at the end of this road, that I was able to then continue the adventure that began in Salta, when Belicena Villca was assassinated.

It only remains for me to make a warning: it is necessary to read these pages with the Spirit devoid of dogmas and prejudices. If one does so, then its contents, like a cup of ambrosia, will be drunk with the eyes and will supply the Spirit with the nectar of the Hyperborean Wisdom. If it is not read in this manner, then it will be as if one were attempting to eat an indigestible delicacy and, like a hard *cattle kneecap* that is neither well cooked nor better chewed, the text will drag along sharp bones that will tear the throat and bother the stomach. In the latter case, I refer the reader to the warning that I inserted in the disclaimer:

"Reader, think that by reading this book you set foot on a land seldom trodden by others..."

Dr. Arturo Siegnagel

Post Scriptum: Constantly remember that throughout this third book, the voice of the story is always Uncle Kurt.

Kurt von Sübermann's Three' Dissertations on the Hyperborean Wisdom and the **⚡**.

1. The absent Third Dissertation, "The Incredible Secret of H. Himmler," was either never completed, posthumously lost, or its contents absorbed into another book. *Treatise on the **⚡** Psychosocial Strategy* is included as the Fourth Dissertation.

First Dissertation

Secret Societies and the Thulegesellschaft

First Part



he Thulegesellschaft was accepting acolytes from different social strata, constituting *Closed Circles*, more or less secret. Each one embarked on the study of an aspect of “*German literature, history, or art*” (such was the description of the aims of the Thulegesellschaft in a pamphlet from 1919) and evolving in the respective theory, by meditation, investigation, or transcendent revelation, until exhausting the intellectual possibilities of this or that idea. There was thus a whole gamut of Closed Circles made up of human groups of different spiritual levels, from the highly esoteric like the *Gesellschaft für Welteislehre*, led by Professor Hörbiger, to the purely frivolous like the *Mittwochsgesellschaft*, to which Dr. *Albrecht Penck*, Ambassador *Ulrich von Hassell*, *Jens Jessen*, General *Ludwig Beck*, etc., were belonging. With reference to this last “closed circle,” quite open by the way, I cannot but recall a principle of the Psychosocial Strategy that says “peripherality, insofar as it implies moving away from the center, favors contact with foreign circles” since this circle consequently betrayed Germany and the Führer from 1938 onward, yielding to the nefarious influence of the elementarwesen and spying for England and the Allied powers.

In that year of 1937, the Thulegesellschaft had interpenetrated, with its closed circles, the entire intellectual body of Germany, so that there was practically no official or private scientific organism that did not have members of the Order. Just as the NSDAP was interpenetrating the entire social body of Germany, the Thulegesellschaft, the hidden counterpart of the NSDAP, was extending its circles throughout the thinking society of the Third Reich.

Certain closed circles, which due to their scientific nature were requiring a special infrastructure and the consequent support of the State, were virtually converted into “exoteric circles” and were henceforth assimilated as official bodies, continuing however with their secret investigations. In the **⚡**, for example, several of these circles were exteriorized, such as the *Ahnenerbe Institute* impulsed by Dr. Rosenberg and the **⚡**, which organized Ernst Schäfer’s expedition to Tibet (*Operation Pamir*) or the *Race and Settlement Office* run by *Walther Darré*,

member of the Thulegesellschaft and author of the seminal book *Blood and Soil*.

It is understood that such disparate circles, each one advancing in its particular theory and closing around this or that occult ideology, were generating a kind of circumscribed fanaticism that was making it inconceivable that “contact” could take place between closed circles without causing grave conflicts. For this reason, the internal security measures of the circles were extreme, even to the point of having “sealed cells” due to the hermeticity of their procedures. In light of these incomplete references, it could be inferred that the Thulegesellschaft was organized on the basis of a cellular system like that which the Communist Party propitiates in order to subversively undermine Western Democracies; but such an assessment would be an error and a gross simplification of the most powerful and best assembled Secret Society in History.

The Bolshevik cellular system is “vertical” in terms of hierarchy and “triangular” as far as Security is concerned. Its strength resides in the “mesh” phenomenon that enables clandestinely structuring hundreds of “cells” by appealing to the security provided by the fact that, in each cell, there is only one member who has a superior “contact.” For greater clarity, let us see how an elementary mesh is formed: see Fig. 1.

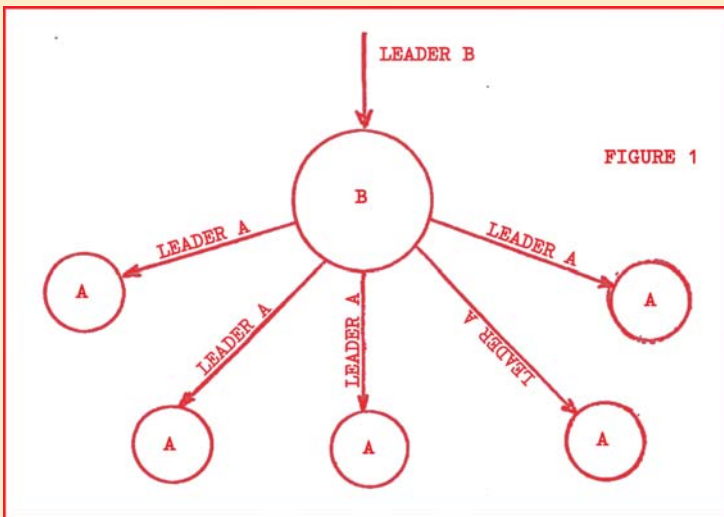

An “A” cell has, let us say, seven members and one leader, the only member who has the “contact.” Let us suppose a “B” cell, formed by the leaders of five “A” cells. Here five leaders

coordinate the control of 35 men in a “B” cell. In the “B” cell there is a sixth man who acts as the leader of the group and knows the superior “contact.” Let us now assume a “C” cell formed by three “B” cell leaders and a fourth man cell “C” leader, etc.

It is elementarily proven here how four men control one hundred and five bases with certain security.

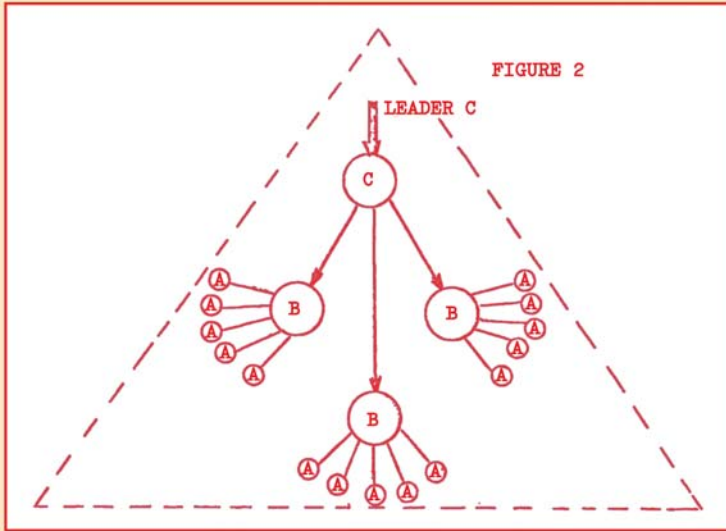

Many variants exist in the cellular system according to the aim pursued by the clandestine organization. If it is desired to increase security, for example, a “univocal link” can be established by arranging that each “A” leader receives instructions through a “volant contact” with the “B” cell, so that the “A” leaders do not know each other, etc.

In a clandestine cellular organization, regardless of its objectives, it must operate according to the principles of military *intelligence*, but bearing in mind that clandestinity implies the consideration of certain special laws. For example, there is a directly proportional relationship between “security” and “information transit time,” so that “the more security, the longer the delay in communications.” In a movement that must act under official repression, this law becomes visible when, for security reasons, contacts are indirectly made, for example through hidden mailboxes, which painfully delays communications between leaders and cells.

Considering these elementary principles of the cellular system, I can assure that the Thulegesellschaft and its closed circles were functioning on the basis of *essentially different* laws and principles. Rudolf Hess had already given me a hint about this intimate constitution that night at the Chancellery when suggesting me *to tighten the circle*. But, since I began my visits to Gregorstraße 239, I have been able to intimately comprehend the incredible “organization,” so to speak, of the Thulegesellschaft. That is why I insist on establishing the differences with all precision.

It seems that between 1919, the official founding date, and 1923, when the first green-bonnet lamas arrived in Munich, the Thulegesellschaft was organized on the basis of the vertical and cellular schema, similar to Freemasonry. It was at that time, 1923 to 1926, that a “revolution” was produced in the internal structure of the Order (with the departure of Baron Von Sebottendorf in 1923), giving rise to the “new” (very ancient) circular layout that was to function until the end of the war. From that period, the recollection of its previous functioning remained and, in fact, few noticed the change. There was a purge and numerous defections, but internally the secret became more hermetic than ever.

The reasons for this change were two, which will be seen in detail in the following account; one secondary and the other primary: the secondary reason was a “pact” entered into in 1923 with a certain Order of lamas from *Lhasa*. The primary reason, and undoubtedly the key to the whole history, is an event that the Führer protagonized when he managed to *psychically read*, in 1922, a very old book that the *Germanenorden*, mother of the Thulegesellschaft, was possessing since the year 1904 and that no one, not even the greatest philologists of the Reich, had been able to decipher.

But, you may ask, what did the system of closed circles consist in? In order to decipher it, it is not possible to use “geometric analogies” as in synarchic organizations (e.g., “triangular and vertical”). At least, not “Euclidean analogies,” given that more than three dimensions would be involved here. It will be seen why: when speaking of “circle” (closed, internal, external, etc.), what is done is to indirectly allude, “induce” is the word, to something that is not named, but which the word “circle” implies. This “something” implied by the “circle” is the center. And here comes the original, the incredible, or, if you

will, the irrational: all the members of the multiple circles, they were affirming that the center, *their center*, was the Führer.

Perhaps, if one does not meditate on it, the abnormal character of this affirmation is not immediately comprehended. For this is not a doctrinal or dogmatic “idea” common to all the members of the Thulegesellschaft, but a *reality* experienced by all and, without a doubt, true. That is: in multiple circles, without contact with each other, by persons also unknown to each other, the strange phenomenon was occurring that they were all perceiving the *same center* around which they were ordering themselves. Think about what this signifies: many circles and a common center. What geometric analogy does it suggest? It will be said, without thinking: a sphere. And the answer will be negative, because the mentioned closed circles are *displaced in space*. Nevertheless, they retain the property of having a common *center*.

“Then the center is not in this world,” may be a hasty conclusion. Well, there is some truth here. But, let us not forget, the center is the Führer, which would signify that “there is something, which is not in this world, in the Führer, perceived by all as the center common to the closed circles of the Thulegesellschaft.” Absurd? No more than the many dogmas and customs that we profess and accept on a daily basis.

Let us continue with the analysis. It is well known that, outside of the three ordinary dimensions, the imagination has serious difficulties in imagining, for example, a fourth or fifth dimension. This is the reason why the previous idea is incomprehensible, in truth, “irrepresentable.” But, if we accept that the “closed circles,” as formed by the Viryas, have a concrete manifestation in this world and that only one part of the problem is *analogically irrepresentable*, the question of the common center; if we accept this, I repeat, we can attempt to utilize an *analogical model*. That is to say, if we are in the presence of a phenomenon, the manifestation of which occurs in several dimensions, there is no difficulty in “visualizing” that part that noticeably affects us in our concrete world; that is to say, that “aspect,” that appearance of the phenomenon, which we sensorially perceive. The “other part,” that aspect that escapes our perception, but which is abstractly apprehensible by reason, insofar as it is capable of establishing a mathematical (not geometrical) analogy of the phenomenon, is *intuitable but not representable*, except *beyond* reason.

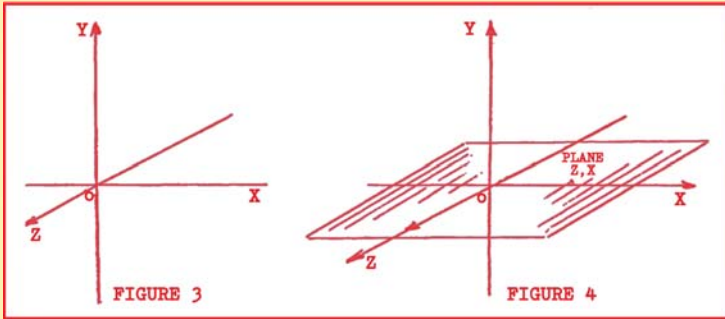

With these precautions, I propose to consider the following model that will enable us, as I already said, to visualize a part of the problem.

Let us suppose a space coordinated by three orthogonal axes, X, Y, Z (Fig. 3). The plane (Z, X) is the “place” where human “organizations” are depicted, Fig. 4. This representation is “direct,” by analogically similar geometric profiles. For example, a vertical and triangular “synarchic” organization, already described, will possess a “triangle” by profile (Fig. 5).

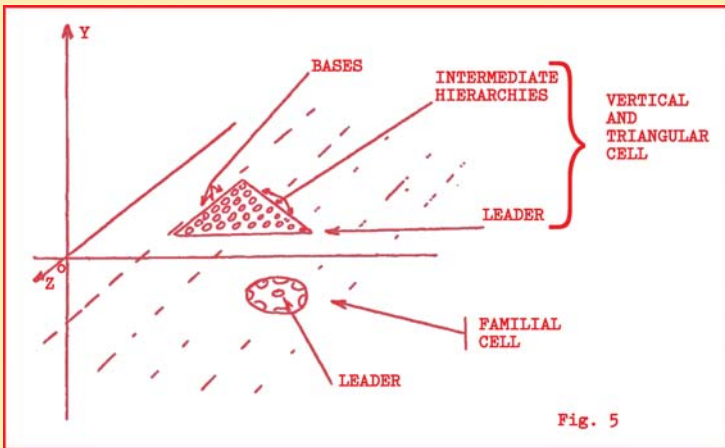

In this model, the *most general representation* of human organization is the *cell* (family, association, etc.); and within the *family of all the cells*, those that are *morphologically indeterminate* (Fig. 5).

Let us take a closer look at this concept. For a cell to exist, three basic conditions must be met: a plurality of members, a common objective (*aim*), and an agreement about the *means* to fulfill the common objective (integration). In every cell there

are natural roles (leadership or command, logistics, security, welfare, planning, etc.) that, as long as they are rigidly and permanently occupied, *determine the cell morphology*. *The most particular* case of *morphological rigidity* is that of an official army, which will always have a vertical and triangular profile.

A bar of friends, meeting once a month to have fun, also form a cell (they fulfill the three conditions) but the roles not being “filled,” or having a “rotation” of roles (e.g., a different “boss” at each outing), causes a *morphological indetermination* that is the *most general* case of analogical representations, and signifies that such a cell can adopt *any form*.

Returning to the representation of a vertical, triangular cell, a typical case of a synarchic organization, it can be observed in Figure 5 that the profile is indeed a triangle.

If what has been explained so far has been comprehended, we can face the representation of the “closed circles” of the Thulegesellschaft. For this we must reason that if a triangular cell was corresponding to a triangular profile, a circular meeting will correspond to a circular profile.

Let us suppose, for greater ease in the analysis, that any “closed circle” has a profile equal to a geometric circumference, and let us remember that in such a figure “the points of the perimeter keep a *fixed distance* (or radius) within.” But closed circles, as we have already seen, have a point, the center, “outside” of them. This condition causes that, from wherever said point is, it maintains the geometric relationships of the fixed distance or radius with each point of the circle profile. And this condition leads us, reasonably, to suppose that the circle profile is the base of a *cone* of which vertex is the center that is “outside of it,” that is to say, that it is an *analogically transcendent center*.

In the Hyperborean Wisdom this virtual vertex is called the *charismatic center* and is considered “situated” on the plane of the Hyperborean Siddhas, which is temporally *desynchronized* with the material world of the Demiurge Jehovah Satan (Fig. 6).

Now compare the triangular synarchic cell and a closed circle of the Thulegesellschaft and you will get an idea of the irreconcilable differences between the two “organizations.” I will note, in six commentaries, the principal conclusions to be drawn from such a comparison:

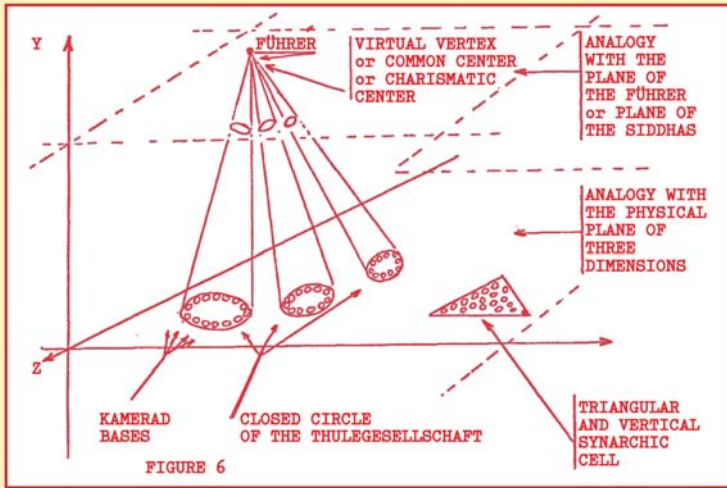

1° - The triangular synarchic cell has no transcendence outside of the X, Y, Z physical plane. The closed circle has its maximum authority, the Führer, illuminating the centers from the plane of the Siddhas.

2° - The hierarchy is vertical (horizontal in the drawing, Fig. 5) in the synarchic cell, and depends only on the echelons of power. No matter how said echelons are occupied (by the inept, climbers, arrivistes, Jews, or simply criminals, etc.), the iron law of the vertical structure is “he who is below obeys he who is above.” In closed circles, the only hierarchy is to the Führer. *Camaraderie* governs among the members. Depending on the “social façade” that the circle must fulfill, there can be a relationship of organic hierarchies for the profane, exoteric view; but internally, all are *kameraden*, that is to say, gentlemen with equal duties and rights. *Only the authority of the Führer is not disputed.*

3° - In the synarchic cell it is necessary for the bases to literally look upward (in the drawing it would be from left to right, horizontally, in the direction of the X axis) in order to visualize the maximum hierarchy (general, pope, high priest, rabbi, etc.). In other words, an external, sensorial gaze is required, with all that this profane search implies: *time*—it may take time to locate a hierarch of the Synarchy; *space*—it may be necessary to move around in order to locate a hierarch of the Synarchy. In a closed circle, the kameraden must look *inward* in order to visualize the Führer, the only hierarchy on Earth. Neither time nor space is required, because the “charismatic

bonding” that the Führer effectuates from his charismatic center, common to all in the synchrony of events, is immediately intuitable by the blood Minne.

4° - The “progress” in a synarchic cell occurs “through time” (advancing from left to right along the X-axis, which also represents the “direction” of time), climbing the lines of the triangle and trying to reach the summit. It is a “material progress,” purely illusory, which only signifies a relative change in the social position within the cell. The position in the hierarchy *keeps no relationship* to any spiritual value of the candidate; for example, a man may “ascend” in the hierarchy, which signifies that he is materially “superior” to his subordinates, but at the same time, if he committed a crime in order to ascend or climb, he may be spiritually “inferior” to those to whom he commands. *Progress in a synarchic cell is, in all cases, evolutive.*

In a closed circle of the Thulegesellschaft, Figure 6, one neither definitively moves forward nor backward. It could be said that one turns in *circles of Eternal Return*, but this idea, as we will see further ahead, implies much more. The “progress” here, if one wants to utilize such a misleading term, is given by the Virya’s possibility of recovering the Blood Memory, the Minne, and transmuting himself into an immortal Siddha, into a divine Hyperborean. Nothing binds the Virya to the illusory world of Jehovah Satan other than his chromosomal confusion, his blood impurity that keeps him temporally lost to the Hyperborean race of Khristos Lúclifer. His goal is outside time and space, set only on the *return* and immortality.

Progress in a closed circle is, in all cases, mutant.

5° - Lastly, it should be kept in mind that the synarchic cell is the most suitable organism for the development of the Paśu or animal-men, who, due to their eminently logical mental constitution, believe to *progress and evolve* in their movements through the hierarchical triangles. The Paśu, as we will see later when studying the **⚡ Psychosocial Strategy**, lacks “Hyperborean lineage”; that is to say, he has never possessed the Vrll, and therefore does not possess the blood Minne. It is, with all precision, a *mental creation of Jehovah Satan*, a pure illusion. For the Hyperborean Siddha the Paśu *does not exist*, the Hyperborean Wisdom says. However, in the illusion of *samsara*, of the world’s becoming, the Paśus possess a *relative existence* facilitated by Jehovah Satan.

Confused with the Paśus are the Hyperborean Viryas, semi-divine ones, toward whom the action of the Führer and the Thulegesellschaft is directed, in the search for the twofold effect: “to obtain the collective transmutation (we will see that it is necessary to give another meaning to ‘collective’ in the Hyperborean Wisdom) and to put an end to the Kaly Yuga or Dark Age.”

For all these reasons, it must be considered that it would be “impossible” for a Paśu to integrate a closed circle of the Thulegesellschaft since, lacking “Blood Memory” or Minne, he would be prevented from perceiving the “center,” that is, the charismatic bonding of the Führer, and therefore “by not having a center, there is no circle,” i.e., *the closed circle does not exist for the Paśu.*

7° - To all that has been said, it could be added, as an illustrative piece of information, that the wonderful organization of the Thulegesellschaft in closed circles, as we have seen it here, was still surpassed after the War by the Anael² Order of Latin America, founded by the Siddhas in Brazil, Argentina, and Chile in 1946, and which still functions in the most perfect hermeticism. The improvement is due to the fact that this time there was no need to institute “many circles,” as in the Third Reich, and it proceeded to build a single circle like that of Figure 7.

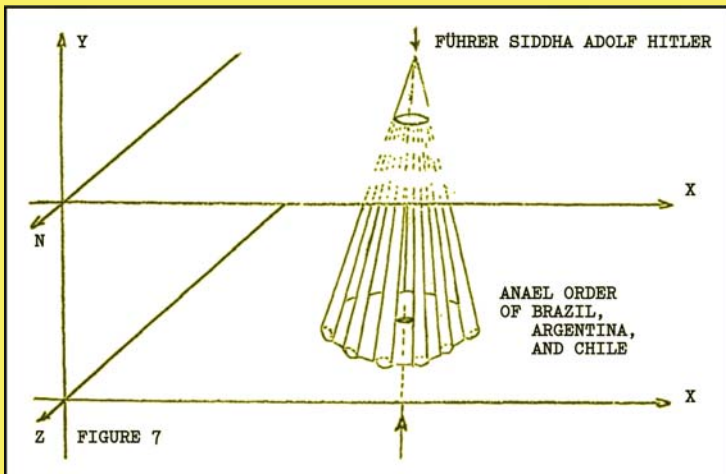

2. ANAEL stands for Avanzada Nacionalista Argentina en Liberación (Argentine Nationalist Advance in Liberation).

There, each rung A, B, C, ... etc., is a sealed cell (political, military, esoteric organization, etc.), which represents the “spokes” of a wheel (of Surya’s chariot, says the Hyperborean Wisdom); but in which the “center of the axle” is on the plane of the Hyperborean Siddhas.

Thus, instead of base comrades as in the “closed circles” of the Thulegesellschaft, there are rungs of the Anael Order forming a “closed circle of power.” The Führer, however, as an immortal Siddha, charismatically illuminates the Siddha Tulkus from his Hyperborean abode in the Valhalla of Agartha.

With these six commentaries and the observation of the analogical model, one will have an idea of the existing essential difference between what we call a typical synarchic Secret Society and the *circular formation* of the Thulegesellschaft.

Second Part



With the necessary reservations, considering what has been said so far, we will call the Thulegesellschaft a “Secret Initiatic Society,” because in the closed circles, up to the “penultimate circle,” the “Hyperborean initiation” was granted to certain members. After 1933, this ceremony became the exclusive use of the ⚡ and from 1936 onward it was only performed in the ⚡ castle of Wewelsburg, which gives an idea of the importance that Heinrich Himmler and the ⚡ gave to the Thulegesellschaft.

As I received this initiation and would like to talk about it, I find myself in the same case as before, when beginning to describe the circles of the Thulegesellschaft. We must also differentiate here what is meant by “Hyperborean initiation” and not confuse it with the “synarchic initiation” that the Synarchy grants in its theosophical and Masonic schools, mainly intended for the Paśu and the lost Virya.

In order to make these concepts clear, it is convenient to start at the beginning and analyze the initiatic Secret Societies of the Synarchy, and then go on to study the Thulegesellschaft.

When considering the history of Secret Societies, a distinction is usually made between Secret Initiatic Societies and Secret Political Societies, according to their transcendental or temporal character. One would take into account, for this classification, “the aims” of the Secret Society, understanding that the pursuit of a purely temporal objective like “the taking of power” or the triumph of a “subversive” ideology or the administration of justice “by one’s own hand” in times of crisis, etc., correspond to a Political Secret Society.

History records numerous political secret societies that would come to form classic examples: the *Holy Vehm* in Germany, *fourteenth* to *nineteenth* centuries; the *Bavarian Illuminati*, *eighteenth* to *nineteenth* centuries; the *Carbonari* in Italy and France, *nineteenth* century; the *United Irishmen*, the *Sinn Féin*, and the *IRA* in Ireland, *seventeenth* to *nineteenth* centuries; the *Ku Klux Klan* in the United States, *nineteenth* to *twentieth* centuries; and the *Mafia* (a criminal but also “political” secret society) in Sicily, USA, and almost the entire Western world, *eighteenth* to *twentieth* centuries; etc. A multitude of

Death Squads and similar paramilitary organizations would also belong to the political branch, and even Marxist or *Trotskyist* organizations that move in the underground.

It is affirmed, when establishing the mentioned distinction, that the triumph or achievement of the declared objectives, automatically extinguishes the Political Secret Society: a clandestine organization, the only aim of which is to favor the taking of power by a group of conspirators, loses its *raison d'être* when the revolution triumphs. The disappearance in History of many Secret Societies (some of those named and others) would seem to support this criterion, which, as Konrad Tarstein was affirming, is completely erroneous.

There are, indeed, Secret Societies with strictly political objectives, but their number is minimal and their existence ephemeral. On the other hand, many of the classic Political Secret Societies, the activity of which spans centuries, either hide their initiatic character, or are linked to an Initiatic Secret Society. This is the true hidden lung that breathes the vital energy of some “mysticism,” for faith in something transcendent is the only “secret” in order to endure for centuries. “There is no social or political demand that is not purely secular, for every righteous claim disappears with the generation that raised it.”

It must then be considered that every political secret society obeys, in one form or another, an initiatic secret society, and, except for the Catena Aurea that we will see later, all secret initiatic societies, at least in the twentieth century, constitute the international synarchy; they are its tactical deployments.

We have seen that the distinction between an Initiatic Secret Society and a Political Secret Society is erroneous, or at least insufficient. But what is an Initiatic Secret Society, of which we say that the Political Secret Societies obey and to which we attribute the conformation of the tactical structure for the Synarchy's strategic action?

Let us see the question duly developed in parts.

A *society* is a human group assembled in order to fulfill a common objective. A *society* is *secret* if the sought objective (*aim*) or the *means* necessary for it must escape public attention (the *aim* may not “morally” justify the means). But a Secret Society may also be official or underground, according to the following law that is deduced from the fact that, there is a directly proportional relationship between the “spirituality” of

an organization and the official Power: “The closer a Secret Society is to Power, the more exoteric (less esoteric) its internal doctrine will become.”

This law indicates that, for the purpose of preserving a certain spiritual patrimony, clandestinity is always convenient and indicates that an authentic “Esoteric School,” if there is one, should be almost inaccessible to the profane.

A Secret Society is *initiatic* when it knows that it is the bearer of a Mystery and regulates access to it by means of a ritual ceremony that transforms the “layman” into an “initiate.”

It is understood that the title of Initiatic Secret Society is only given to those which “secret” knowledge is esoteric and spiritual. Therefore, we must first analyze what is understood by “initiated” and “esoteric” before we fit together a definition for the Initiatic Secret Societies.

The word “initiation” (*initium*) derives from two Latin words: *in* = in; *eō* = to go; that is: beginning. The initiate, in general, is the one who begins something and in the particular esoteric case, “is the one who begins a new life.”

Initiation implies, then, a radical change in the life of the initiate. This has always been so and we can verify it by analyzing the fact of *ritual initiation* throughout History. Ritual initiation is a long-standing institution in human societies, its presence being able to be detected almost without exception in all historical peoples. In primitive societies, even today, it is possible to observe initiation rites, called “rites of passage,” in order to mark the passage from boy to man, to his participation in adult life.

Initiation is then the *initium*, the beginning of a new life, whether as an adult, spouse, hunter, or warrior. But the matter is among the most suggestive and it is worth analyzing in greater profundity. All of these examples show that initiation is an experience of an eminently social character, for initiation can only be administered exteriorly, from one’s fellow man, with collective participation. For the phenomenon of initiation to exist, there must simultaneously be the operation of an initiatic community, for the *individual* initiation *experience* requires a *collective* initiatic *experience* ritual.

Let us also note that, since its remote origins, initiation is a practice *committed* to the society in question, which has favored the passage from the layman to the initiate precisely be-

cause it relies on the participation of the latter in responsibilities that will be revealed to him in due course.

On the other hand, if to be initiated is to begin transiting a new path, this change is by no means easy or pleasant, many of the problems of alienation and neurosis that the White race currently endures originating in the oblivion of ancient initiatic practices. In effect, the passage from "child" to "adult" was performed by means of a ritual ceremony that was preparing man for various changes that accompany the entry into the new life, among which, of no small importance, are: the abandonment of the mother, the responsibility to contribute to the common nourishment, the certain prospect of death, etc. (when one is a child, the "next stage" is that of an adult; when one is an adult, the "next stage" is old age; and when one is old the next step is death. Plausibly, the "passage" from child to adult poses, among other "changes," that of death). Initiation has the virtue, in this case, of preventing traumatic after-effects by "establishing," with the force of social law, that the initiate is tacitly prepared in order to "begin to walk the new path," which evidently morally supports the candidate.

Among us, the passage to adulthood takes place gradually due to the lack of the precise and inexorable limit that would be an initiation ceremony and involves painful and often traumatic experiences. There are those who never really manage "to leave" their "mother," suffering a sort of perpetual external domination and the consequent internal insecurity due to the created psychological dependence.

When we say "leaving the mother" we make reference to the "maternal archetype" and we do not encourage, in any way, a situation of exile from our loved ones. The proximity or distance from the carnal mother in no way alters this complex that generates the "softness of character" and "sentimentalism," so it is necessary to assume with plenitude all of the psychic potentiality that man has; this will be the first step in the search for individuation.

Thus there are men who never cease to be children, and men who never become adults, because of the gradualness of the "passage," lacking the limit set by initiation. For some centuries, this situation tends to correct itself in the White race with the natural appearance of a *new age* between childhood and adulthood called *adolescence*, which is a euphemism for the state of *total idiocy* into which the young man falls, for a

more or less long time, but which happily has the beneficial effect of attenuating the impact of exterior changes when taking the “step.”

We have already made clear what initiation is in its general meaning. Let us now look at its esoteric significance.

By esoteric we mean, as the Greek word *ésotheó* (ἔσωθεο) indicates, an entering into the mystery. Therefore, when we speak of “esoteric initiation,” we mean a commencement (initium) on the one hand, and an “entering” (*ésotheó*) on the other. It is well known that, since Aristotle, the esoteric is opposed to the exoteric or profane in the field of knowledge. But this knowledge to which the esoteric alludes is not precisely an “occult knowledge” because of its secret nature, but because of the quality of its categorically hierarchical “privileged knowledge.”

Esotericism opens a door “to pass” (*ésotheó*) from a profane world, gnoseologically based on false categories resulting from an erroneous perception of what is real, which in turn is illusory in its concrete materiality, to another spiritual world of pure metaphysical perceptions, considered, paradoxically, as truly real.

However, the door that esotericism opens cannot be passed through by anyone; not all laymen are qualified to access such a “superior” knowledge. “Esoteric knowledge” supposes the “privilege” of its knowledge and requires a “control” on that door that opens in order to gain entry, *ésotheó*.

This control is precisely the “esoteric initiation” of the laymen who are qualified for it, that is to say, of those men who are “initiable.”

We have already spoken of the ritual initiation and we went into examples about the “rites of passage,” showing that the initiation, initium, supposes a permanent change in the initiate who begins, starting with the initiating rite, “a new life.” In esoteric initiation, this condition is taken to its ultimate consequence in such a way that the initiate must experience, as a rite of passage to the new life, an *authentic death and resurrection*. Esoteric initiation is unanimously considered an irreversible experience, so that if the initiate does not demonstrate, in the eyes of his initiators, an authentic transmutation, he will not be allowed to live to tell the tale.

In order to comprehend this terrible affirmation, we must consider the fact that esoteric initiation is a very ancient and

universal practice, historically recorded in all known cultures, which is why we have abundant information, especially from the great ancient civilizations where esoteric initiation experienced periods of authentic splendor.

But in Antiquity, esoteric initiation was administered by priestly castes that were responding to the official cults of the various peoples, and the deities involved in the rites of the Mysteries were always racial gods. Thus, we know “Mystery Schools” or “Cults,” typically initiatic possessors of a particular religion or myth, many times analogous in their symbology, for each peoples or ancient race. Among the best known we can mention in Egypt: the Mysteries of Osiris and Isis; in Greece: the Mysteries of Dionysus, the Mysteries of Eleusis, the Mysteries of Orpheus, the Order of Pythagoras, etc.; in Iran: the Cult of Mithra, Mazdaism, Manichaeism, etc.; in India and Tibet: Hinduism, Tibetan Buddhism, Shaolin, etc.; in Japan: Shintoism, Zen Buddhism, etc.; in Islam: the Sufi sect, the Order of Assassins, the Druze sect, the Alawite sect, etc.

In all of these ancient Mysteries, and many others, the esoteric initiation was acquiring analogous forms with regard to the entrance of the neophyte and his subsequent initiation. It is based on the universal concept that esoteric initiation is “*a process intended to psychologically carry out in the individual the passage from a reputedly inferior state of being to a superior state, the transformation of the layman into an initiate; through a series of symbolic acts, moral and physical tests, it is a question of giving to the individual the sensation that he ‘dies’ in order to be ‘reborn’ to a new life.*”³

In this general overview of esoteric initiation, it is worthwhile to dwell on the last quotes and also to note the “moral and physical tests” and the “symbolic” acts. The physical tests to which the audacious neophytes, considered “initiable” after suffering long and vexatious novitiates, were subjected, generally ended their lives. We will not go into examples, but it is worth making the elementary reference that such physical tests consisted in the confrontation, unarmed or when not

3. *Les sociétés secrètes*, Serge Hutin, 1957; p. 6, “un processus destiné à réaliser psychologiquement chez l’individu le passage d’un état, réputé inférieur, de l’être à un état supérieur, la transformation du «profane» en «initié» ; par une série d’actes symboliques, d’épreuves morales et physiques, il s’agit de donner à l’individu la sensation qu’il «meurt» pour «renaître» à une vie nouvelle.”

drugged, with “sacred” animals of more or less ferocity, such as lions, crocodiles, venomous snakes, etc.

The surviving neophytes then faced “moral tests” that usually consisted of suffering humiliations of various kinds “in order to demonstrate humility”; resisting the assault of ardent and beautiful priestesses, often after having ingested aphrodisiacs under deception, “in order to demonstrate chastity”; to perform certain physical feats such as resistance to pain or fear “to demonstrate organic mastery”; etc. Failure in these moral tests did was not necessarily signifying death, but the immediate expulsion of the unfortunate aspirant. In any case, this is a general assessment; since in many mystery cult ceremonies, simultaneously with the novitiateship, certain secret teachings were imparted that were not to be profaned, the priests proceeded in those particular cults to execute the failure.

Finally, the “symbolic acts” refer to the initiatic ritual itself, which, as is logical, was varying from one Mystery to another, but which in all cases had the aim of producing a psychic unfolding in the neophyte that would allow him to carry out the transcendent *journey*. This “journey,” an indispensable experience in order to obtain initiation, consisted, according to all references, in the transit of the “ego” unfolded along an “otherworldly” path. Such a “path,” which in its fantastic route toward exalted deities, was nevertheless crossing infernal abysses plagued with unspeakable terrors, was in every way similar to that which we tread in our “last journey,” the one that we all make at the hour of death.

The “return” to life, after the initiating journey, was the authentic triumph of the neophyte, now initiated, and was interpreted as a true “second birth.”

Of the neophyte, of his lay mind, nothing had survived after the initiating death; the resurrected initiate, on the other hand, was considered a new being, possessing a knowledge obtained *beyond death*.

As an epilogue to this commentary on esoteric initiation, we must consider the influence that the passage of time has had on this transcendent experience, from Antiquity to the present day. We will make this evaluation using a criterion that Konrad Tarstein was constantly repeating to me in those days: History, as we understand it in its documental sense, which “begins for us with decipherable and comprehensible written testimonies,

which in different countries correspond to completely disparate epochs," is but a part of the Dark Era called by the Indo-Aryan peoples Kaly Yuga, Iron Age, or Age of Darkness.

Later we will expand on this concept of History. For now we must consider that these "darknesses," which advance along with History, are intellectual blacknesses that envelop the Spirits, gradually depriving them of all transcendent light. This spiritual opacity, which implies the "loss" of metaphysical faculties once common in the Viryas, has been syndicated as responsible for the materialistic tendency that civilizations have followed. It has also signified the ruin of historical civilizations, including our current Western civilization, already involved in a crisis of decomposition and cultural decadence.

On this negative slope of History, esoteric initiation has met the worst fate. Arisen from a context that we call Ancient Wisdom, it was for thousands of years an effective practice in the priestly function of all civilizations. But the general decadence, which at different epochs enveloped the peoples, put an end to the "gnostic content" of the Mysteries. Of course this was due to human decadence more than anything else, for when the eye hardens and the soul dwells in darkness, the Mysteries, which are no more (and no less) than symbols, lose their operative capacity, do not "reveal" their secret to the priests, and all succumb to superstition and myth.

Thus, in a slow degradation, the metaphysical "contents" begin to be lost and their "container," the *ritual form*, is exalted to the point of desperation (or fanaticism) in a vain pretension of forcing the emergence of the metaphysical "content." But it is useless; the living Mystery has been transformed into a myth; the ritual is an empty shell of "content"; the initiation is a theatrical performance, all the more shrouded in "mystery" as it is hollow of spiritual realizations.

It is the Kaly Yuga. Initiation will no longer be "esoteric," for there will be no "door to open" and no Mystery to know; but "exoteric," profane, because the priestly function was profaned, without exception, in the last millennia.

However, today we hear talk of "Masonic initiation," "Rosicrucian initiation," "Theosophical initiation," etc., or of Mysteries and Secret Doctrines, which certain modern "schools" would possess. What has happened? Are we facing a restoration of the ancient Mysteries, of the esoteric initiation that was transforming the initiate, twice reborn, endowing him with

the capacity to dialogue with God? Has the Kaly Yuga concluded, taking into account the avalanche of “mysterious” and “initiatic” sects that comes from the East?

Nothing of the sort. Since the beginning of the Kaly Yuga, parallel to the spiritual decadence and the advancement of materialism, some dark “potencies” have been surfacing, the “seat” of which is an “hidden center” of the Earth from which the will of Jehovah Satan is channeled. These diabolical “potencies” are those that decisively contribute to the falsification in which all the religions, cults, and schools of Mysteries of Antiquity succumb, and are those that just in the last century we have been able to clearly distinguish under the denomination of International Synarchy.

For centuries they impulsed the Secret Initiatic Societies to replace the Ancient Mysteries or to infiltrate and control the great religions. But initiation, under the influence of the “diabolic potencies,” has become pure formula. Of the Living Mysteries and the initial esotericism, only a “symbolic” and “speculative” syncretism remains. The “initiatic journey” carried out in a psychic unfolding through the “other world” will now be a walk performed physically, “symbolically” say the Masonic synarchs, through the courtyards of the lodges.

This is how we arrive at the last centuries of our epoch with a marked accentuation of the decadent tendencies of the Kaly Yuga and, consequently, with an increase in *the number* of Secret Initiatic Societies. The latter are responsible for the “avalanche of mysterious and initiatic sects that come from the East” of which we were speaking before.

The “tendencies” of the Kaly Yuga are approaching the zenith and that is why the “diabolical potencies” are now manifesting themselves through the International Synarchy; and that is also why we can clearly distinguish their actions and comprehend their sinister plans.

Returning to the subject of esoteric initiation, we can affirm that it has totally disappeared from the West during the last two millennia. The Secret Societies of the Synarchy have nevertheless used such a label for an “exoteric initiation,” the main objective of which is to nourish their ranks with adepts, sworn to the death, for the sole purpose of fulfilling their plans for world domination.

There is nothing in them that favors the adept’s spiritual overcoming, that is to say, the detachment from the ties that

enchain man with matter and his definitive liberation from the miserable condition to which the material “order” of Jehovah Satan has subjected him. There may be promises in this sense that only respond to the need to momentarily deceive those from whom it is expected to obtain some benefit.

But the black reality is that no one can claim to “be of use” to a Secret Society of the Synarchy, a naïveté that pays dearly; but the Synarchy will use the unwary or accomplices that populate its ranks as it pleases, and if some will benefit with wealth and power while they are useful, it will destroy others when they do not faithfully fulfill its plans.

In the ancient Mysteries, initiation was administered by priests, masters, or gurus, who were watching over the correct consummation of the ritual. The initiates, reborn and wise, were, over time, replacing their former initiators.

In today’s Secret Societies, initiation consists simply in an oath of complicity, similar to that which exists in the codes of the criminal underworld, taken by the “apprentice” or “fellow” or “brother” when, after a symbolic ritual, the “mystery of the Order” is revealed to him and what is expected of him. This “mystery” is none other than “getting to know the Order’s mission in society,” that is, its contribution to the worldwide synarchic plan. Once the neophyte has been “initiated,” that is to say, once he is in on the secret of the Synarchy, he must take an oath that will prevent him from ever leaving the Order under penalty of “ritual death.” The exoteric initiate is, then, irremediably lost; for if he defects from his lodge he will be quickly executed; and if he continues in it, “progressing in the degrees” and “fulfilling the tasks,” his only recompense will be material triumph since, in his innermost being, the Spirit will flee from whomever sinks into synarchic Satanism.

Let us make a summary. We said that Secret Societies are usually divided into Initiatic Secret Societies and Political Secret Societies, but that such a division is illusory because all Political Secret Societies depend on Initiatic Secret Societies. The latter, together, constitute the *main body* of the Synarchy, still underground but ready to emerge in the most powerful of all organizations ever dreamed of or seen on Earth: the *World Government of the Synarchy*.

We studied ritual initiation and esoteric initiation and found that the Secret Societies of the Synarchy, even when

they claim to be “initiatic,” do not practice a true ritual of “death and resurrection” suitable for the Viryas.

These, on the other hand, “initiate” by means of a prosaic “ritual,” based on a code of complicity and temporal secrecy proper to the criminal cells that they actually constitute. Cells that by their vertical and triangular character are suitable for the Paśu and, eventually, the lost Virya.

Only the following can be added: the Thulegesellschaft is the only, let it be understood, the *only* Hyperborean Initiatic Secret Society that has operated in the West in the last 700 years. The “Hyperborean” is due to the fact that the Thulegesellschaft is the depositary, not of a “Mystery,” but of the Hyperborean Wisdom, which is the mother of Mysteries. From this point of view, except for the Thulegesellschaft, all of the Initiatic Secret Societies are mere forgeries of the ancient ones, made by the Synarchy.

In the course of the story, this affirmation, which seems so adventurous, will become evident. To the extent that we understand the Hyperborean Wisdom and its guidelines of criteria, and set forth the Plan of the Synarchy, we will be able to carry out the *philosophical filiation* of many Secret Societies or organizations that *erroneously do not consider themselves to be synarchic*.

Second Dissertation

Secret History of the Thulegesellschaft

Introduction



It is a more or less well-known fact that the Thulegesellschaft—the men who founded it—arose from the bosom of the Germanenorden; but everything that is usually speculated beyond this precision, in books and articles published for defamatory aims, is mere nonsense. However, there is a marvelous history that allows us to trace the origins of the Thulegesellschaft and the Germanenorden back to the sixteenth century, but it is known only to the initiates of the Black Order, that is, to the **⚡** leaders; and it has never been publicly revealed until today. This history will now be exposed so that its powerful light dissolves the darkness of ignorance in which the memory of the Third Reich is shrouded and clearly shows the occult motivations that were impulsing the Führer and his **⚡** leaders.

The first link that unites the Germanenorden with the past is a German Secret Society founded in the sixteenth century under the name of Sapiens Donabitur Astris. This last Society painfully survived until the end of the nineteenth century, which we could call the “century of the Synarchy,” in order to succumb to a metaphysical fall during the first years of the twentieth century. But notwithstanding its definitive “synarchic overthrow,” before falling, it achieved to comply with the purpose for which it had been founded: *it formed men and gave to them the secret*. Theodor Fritsch, Rudolf von Sebottendorf, Dietrich Eckart, etc., are some of the *men*.

The secret consisted of an armored trunk with steel bars, constructed in the sixteenth century, which remained in the possession of the Order for three hundred years until the arrival of the times... This trunk and other elements were finally entrusted to the greatest Hyperborean mutant of the twentieth century: Dietrich Eckart, the initiator of the Führer. Such is, in short, the history that we intend to tell, the origin of which dates back to the sixteenth century.

But during the story we will move away from the sixteenth century many times. We will go backward in time and space and stop in Assyria, 2,000 years before the current era. Then we will briefly pass into thirteenth century Sicily, at the court of Frederick II Hohenstaufen, and then we will stop well into

the sixteenth century in order to travel to England, Spain, America, Flanders... but nevertheless, our starting point will always be the same: the court of Rudolf II Habsburg, in Bohemia. We must not forget Atlantis, because in the course of our story we will often refer to its lost science and its ignored races.

It is possible that someone may wonder if it is justified to resort to remote historical arguments in order to explain some occurred events in the twentieth century. However, all these disparate places and situations, apparently unconnectable among themselves, possess *a non-causal nexus* that passes infallibly unnoticed to the synarchic gaze, but which shines and regally manifests itself in that Hyperborean relationship that bonds the Viryas on the path of return, in that *Catena Aurea* that can only be followed if one has felt the Minne and has committed oneself to participate in the cosmic war. In order to perceive this synchronistic nexus, we must relentlessly renounce the tyranny of reason, the tool of the Paśu, and seek in the blood the *answers to some questions that have never been formulated and never will be*. With this mystical disposition of Spirit, we will now initiate the journey previously outlined. We will begin by going back to the sixteenth century, to the court of Emperor Rudolf II Habsburg, who appears as the remote founder of the Sapiens Donabitur Astris.

This monarch, in addition to being King of Rome, Emperor of Germany, and King of Hungary, was King of Bohemia, which is why his main court was located in Prague, one of the most important cities of the epoch. Addicted to the study of Alchemy and Astrology, these inclinations for mysterious things, however, were not eclipsing his immense culture. He was considered a generous patron of the arts and knew how to gather numerous personalities under his protection. At his court in Prague, he could meet well-known scholars such as the astronomers *Tycho Brahe* and *Johannes Kepler*, as well as esoteric scholars of the stature of the alchemist physician *Tadeáš Hájek "Hagecius,"* the magician *Scottus*,⁴ and the English sage *Dr. John Dee*. Justly, the foundation of the Sapiens Donabitur Astris (SDA) is due to the need for initiating secret studies around documents brought by Dr. John Dee in his journey

4. Scotus, Scottus, or Scotto, whose Christian name remains definitively unknown to this day. He has been referred to as Alessandro, Hieronymus, and 'Odoardus.'

to Prague in 1584, when he showed Rudolf II the famous “talking stone of Princess Papan.”

It is a strange story, typical of that absurd century of Renaissance geniuses and great inventors, but also of selfish kings, religious wars, and a gold rush that destroyed América, piously disguised as an “effort” of Christian civilization to “save” savage and pagan peoples.

Princess Papan's Stone Mirror



It is well known that when Hernán Cortés took possession of *Tenochtitlan* (Mexico) in 1520, he learned that the sister of the Aztec Emperor *Moctezuma II*, Princess Papan,⁵ had prophesied the arrival of White and bearded warriors, a description that was perfectly fitting for the Spanish Conquistadors.

In América, the ruling castes, descendants of Atlantean survivors, were of a purer Hyperborean lineage than the degraded Europeans. That is why they were keeping alive the “memory” of the White Gods and of Khristos LúCIFER, whom they called Quetzalcoatl, which means: feathered, winged, or flying serpent.

This “Blood Memory,” common to all of the White races, was, however, fatal for the Aztecs because they did not know how to *timely* evaluate the strategic confusion that the conquerors were suffering. A Virya's degree of “confusion” is measured by his “Paśu tendency,” a question that requires, for his comprehension, the definition of the corresponding psychological types. This we will give later on; but for now as an example, let us consider that “that surprising greed for gold,” which was transforming the Conquistadors into greedy and selfish beasts, is a typical tendency of the Paśu. For the Paśu is rational and astute, opposed to the Virya who is intuitive and spontaneous. The Paśu, animal-man, “evolves” or “devolves” within the material order; and its “tendencies” can be qualified, with all precision, as *satanic*. The Aztecs, even when they were possessing a certain racial purity that was strategically placing them above the Europeans, were failing to distinguish and evaluate the tendencies of the Paśu and the danger that they were implying. They were, as always in these cases, dazzled by a flaunt of “superior” culture and civilization in the domain of matter. But this “superiority,” represented by the technology to build weapons, warships, and all sorts of material objects, which seems so evident in the face of a “savage and pagan” peoples' lack of means, who believe in a Serpent God

5. Also known as Papantzin; *-tzin* being an honorific and reverential suffix in Nahuatl languages.

from Venus, is completely illusory from a spiritual point of view and constitutes one more characteristic of the Kaly Yuga.

Hernán Cortés astutely took advantage of the prophecy of Princess Papan, who had foretold the coming arrival of the envoys of Quetzalcoatl, in order to pass himself off as the “son of the Sun”; and in an unprecedented military campaign—400 Spaniards against 40,000 Aztecs—took over Mexico. The *Ah Kin* priests, of the solar cult, had also foreseen the imminent arrival of the foreigners who would fulfill the ancient prophecy made by Quetzalcoatl before his departure. How could the Aztecs have made such a mistake, an error that cost them their empire and the definitive collapse of the Anahuac civilization? First of all, let us remember that it was “the last Quetzalcoatl,” he who came to América in the tenth century, who left a prophecy that the Toltecs would not forget for five hundred years: “He announced to them that White and bearded men were to come from the East and subdue all the peoples, destroying their religion and their race.”

“This prophecy,” says Camille Crivelli, “made by a man who distinguished himself from the indigenous people by his knowledge and virtue, by his dress, and even by his white complexion, was so deeply engraved in the spirits that it was transmitted by the peoples from generation to generation. When the Europeans disembarked in America, the prophecy of Kukulcan served them better for the conquest than their swords, and Moctezuma himself, king and superstitious pontiff, believed that to resist the Conquistadors was to oppose the gods.”⁶

This is one reason, but fundamentally, the fall of the Aztec empire must be attributed to the racial degradation of the reigning castes. In effect, the Aztecs had already inherited the memory of Quetzalcoatl from the Toltecs; and the latter in turn took it from an older myth, original to the Maya, who must be considered as a remnant of Atlantean survivors.

Historians, based on a deficient archaeology, expurgated by the Catholic Church and other obscurantisms, usually speak

6. “La religion des anciens Mexicains,” Camille Crivelli, Chapter IV in *Christus: Manuel d'histoire des religions* by Joseph Huby, 1947; p. 157, “The one who seemed to be their leader and lord was called Quetzalcoatl. He was described as a White man of high stature, with a broad forehead, large eyes, thick beard, and long black hair. Chaste, loving peace and justice, prudent and wise, he taught the Toltecs the art of metalworking and revealed to them other unknown industries...”

of two stages in the history of the Maya people: the Old Empire (second century BC to the seventh century AD) and the New Empire (seventh to sixteenth centuries AD). The Old Empire, the classical period of which should be situated around the third century AD, when ironically in Europe the Roman Empire was collapsing, was mastering certain guidelines of the Hyperborean Wisdom, which can be easily discovered by analyzing Maya culture and history. Because, apart from their amazing advances in lithic art, mathematics, and astronomy, the Maya excelled in the Hyperborean Strategy, that is, the social or collective science of the return to the Origin. And the latter is the most important of the social or collective qualities.

In effect, every people or race that stands out in terms of the purity of its Hyperborean Tradition *must manifest these virtues in its strategic objectives*.

The Maya have demonstrated to possess very clear strategic objectives, since they practiced an “inward Imperialism,” which coincides with the Hyperborean techniques of “gaining the center by constricting the circle.” In order to comprehend this affirmation, the map of the Yucatan peninsula, present-day Mexico, Guatemala, and Belize, should be observed, and to consider that the Old Empire extended in a wide triangular area approximately delimited by the cities of Palenque, *Uaxactun*, and Copán. In reality the triangle that the three mentioned sites form is inscribed in a *strategic circle*, which was including, toward the center, the cities of *Naranjo*, *Tikal*, *Piedras Negras (Guatemala)*, *Benque Viejo*, etc., all subsequent to the first three. This is enough to demonstrate the *advance toward the center, constricting the circle*.

Of course, by *dominating* the totality of the imperial area, and the center, the Old Empire concludes its *strategic mission* and disappears from History. But when adopting the Hyperborean Strategy in order to lead a people, it is not always possible to proceed with as much clarity as the Maya have done. The majority of historical cases in which there was a testing of a Hyperborean Strategy—Hittite Empire, Persia, Greece-Macedonia, Rome, Romano-Germanic Empire, Prussia, Paraguay, Germany, etc.—demonstrate that sometimes it is necessary to “expand the circle” until gaining areas of conflict and then “restricting the circle toward the center.” This expansion will unfailingly provoke the reaction of the demonic forces

who, unable to remain hidden during the strategic advance, will be forced to fight even against their will, overcome in their own synarchic infiltration strategy by a more powerful strategy that will implacably unmask them.

The Toltecs received from the Maya part of the ancient wisdom; but, with the passing of the centuries, the *strategic confusion* was becoming greater; and when, in the tenth and eleventh centuries, several Viking—Norwegian and Danish—expeditions were arriving, a *mythical metamorphosis* takes place in the mythological pantheon of Mesoamérica. The castes of the Toltec nobility merge with the newcomer “sons of the Sun” and mistakenly identify the ancient Hyperborean Gods with the valorous and intrepid, but also *confused*, Vikings. Thus appear, among the Aztecs, Toltecs, and Maya, in the sixteenth century, two or three Quetzalcoats: one, very ancient, is the “memory” of the Atlantean Christ; another, an “ascetic” Quetzalcoatl and worshiper of the cross, is nothing but a Catholic missionary; and a third White and bearded Quetzalcoatl, is authentically Viking. The latter is also the Kukulkan of the Yucatan whom Professor Jacques de Mahieu identifies as *Ullman*, a German navigator of the tenth century.

The result of such a fusion between Atlantean and Nordic lineages has been the most terrible strategic confusion, easily verifiable in the mythological fall that the *Huitzilopochtli* cult, practiced in the Anahuac until the arrival of the Spaniards, signified. This God is a primitive form of Jehovah Satan, that is to say, of the Demiurge, and under his bloody aspect of *Huitzilopochtli*, hummingbird magician, he was demanding human sacrifices, forcing his worshipers to maintain a permanent state of war, the *Xochiyaoyotl*, in order to provide himself with victims. His insatiable thirst for human blood was leading the Aztecs to immolate 15,000 to 20,000 men per year.

This degeneration demonstrates that there is a direct relationship between the center of the Demiurge Jehovah Satan, under any of its mythical aspects, and the *perversion of the heroic meaning* that war should have. On the other hand, *Huitzilopochtli* looks suspiciously like the “Gods” that the Druids have imposed among the Celts, all inspired by Jehovah Satan like the Irish *Brân*, whose link to the Hebrew Jehovah is already proven, or *Lugh*, the Celtic God that the Germans called Loki.

The cultural contact between Americans and Vikings produced a syncretism of Christian and Nordic elements with the Nahuatl myths. However, in spite of the fact that the Hyperborean Wisdom was buried under a tangle of *confused symbols*, the peoples of América were possessing a racially purer nobility than the Judaized families reigning in sixteenth-century Europe. The “Blood Memory” of their Atlantean past was still alive in the American “Indians” and, although the dominion of Jehovah Satan Huitzilopochtli was ironclad, Quetzalcoatl was also remembered and *his return intensely desired*.

As an example of the deformed Aztec tradition and their strategic confusion when dealing with the Spaniards, “the speech that Moctezuma pronounced before Cortés, when he went to visit him at his father Axayacatl’s palace, which he had given to his guests: ‘... (I have) you for my kinsmen; for, according to what my father told me, who also heard it from his father, our ancestors and kings, from whom I am descended, were not natives of this land, but upstarts, who came with a great lord, and who after a little while went to his own country; and after many years, he returned for them; but they did not want to go, because they had settled here and already had children and wives and a great deal of control in the land. He became very displeased with them, and told them upon his departure that he would send his sons to govern and maintain them in peace and justice, and in the ancient laws and religion of their fathers. For this reason, we have always hoped and believed that someday those from that part would come to rule and control, and I think that you are the ones, according to where you come from...’”⁷

When Hernán Cortés arrived in Mexico, as has been said, the Aztecs, among them that of Princess Papan, sister of Moctezuma, were possessing some recent prophecies. How had Princess Papan obtained news of the coming arrival of the Conquistadors? By means of a polished stone that was serving her as a mirror and to which, according to an ancient Toltec tradition, she could “speak” with the Serpent-God Quetzalcoatl. This stone, which is nothing more than an *Atlantean transducer*,⁸ was preserved by Cortés until 1540, when he re-

7. *El gran viaje del Dios-Sol*, Jacques de Mahieu, 1971; p. 69. Moctezuma’s speech has been taken from Francisco López de Gómara’s *Conquista de México*, 1553, as cited in Professor Mahieu’s work.

8. The theory of lithic transducers is elaborated further on.

turned to Spain. At that time, the stone passed into the hands of Pedro de Gante, a Franciscan missionary who arrived in Mexico in 1523, a relative of Charles V and Philip II.

A Spaniard born in Flanders, founder of the first school in Mexico at the Convento de San Francisco, the Franciscan missionary was a man of restless Spirit and powerful influences. He showed interest in seeing Princess Papan's famous talking stone, when he learned from Doña Malinche, the Maya princess concubine of Cortés and official interpreter of the Maya and Nahuatl languages, that it was in the possession of the Marquess of the Valley of Oaxaca (Cortés). It is a miracle that this happened; for Cortés, anxious to gain the influence that he was so badly needing in order to overcome the numerous intrigues against him, hastened to send the talking stone to Pedro de Gante. It is a miracle, we say, for in that way he was able to save it from falling into the hands of the Druids, Jesuits, and Dominicans, who were waiting for the occasion to lay hands on it or destroy it.

Pedro de Gante, on the other hand, carefully preserved it for years as a rarity, fascinated by the great polish of the stone, but without revealing its secret. Due to this zeal, Cortés himself decided to leave it to him when he definitively departed for Spain, always in need of influence in the capital of the kingdom. The Flemish missionary, notwithstanding the attraction that the talking stone was exerting on his Spirit, soon abandoned his study due to the exhausting educational task that his mission had taken on.

The talking stone was then deposited in a chest at the Convent of San Francisco, forgotten by all, when the illustrious priest died in 1572.

Surely it would have been lost forever had it not been for an event that we would have to call fortuitous if we did not possess the certainty that a *Catena Aurea*, a golden chain, links the Hyperborean Viryas. For on a trip to Spain that Pedro de Gante made in 1567, while visiting his relative King Philip II, he met at the court two young Habsburg princes of Austria, Ernest and Rudolf, sons of Emperor Maximilian II.

Of these princes, who were otherwise related to him, one of them, 15-year-old Rudolf, seemed, to the missionary, so interested in the native peoples of América and their strange religion that he did not hesitate in recounting to him the most exotic customs of the Aztecs, among them the unusual belief

that a polished stone “was enabling the savages to speak to their Serpent God.” This story greatly moved the future Emperor of Germany for, upon learning that the aforementioned stone was in the possession of the missionary, he promised himself to obtain it for his own someday.

This inclination of Rudolf’s should not be surprising, for in those years he attempted to seize two relics belonging to his family, which today are kept in the Vienna Treasury: the *Ainkhürn*, tooth of the fabulous Monoceros, 243 cm in length by 6 cm in diameter; and the Agate Bowl brought from Constantinople by the Crusaders in 1204, 75 cm in diameter, perhaps the largest carved agate in the world, which he mistakenly believed to be the Gral or chalice used at the Last Supper.

Rudolf studied from the age of twelve at the Spanish court of his uncle King Philip II. The latter had been widowed for the second time in 1558 upon the death of Mary Tudor “The Catholic,” Queen of England and daughter of Henry VIII with Catherine of Aragon. During her short English reign from 1553–1558, Mary combated the schismatic heretics of the Anglican Church founded by her father and reinstated the Catholic religion, supported in this task by Spain, which, under her husband Philip II, had become a bastion of the Counter-Reformation.

But when Mary died, Elizabeth II, daughter of Henry VIII with Anne Boleyn, ascended to the throne of England, supported by the Protestant party, now initiating the persecution of Catholics and some nobles who had supported Queen Mary Tudor. Many of these nobles took refuge in the court of Philip II, where they remained for as long as Elizabeth I’s anger lasted, but were sooner or later allowed to return to England. What is interesting to note here is that the young Rudolf Habsburg lived with them during his stay at the Spanish court and established friendly ties that later allowed him to maintain contact with Elizabeth I, at a time when the war was pitting England against Spain and there was no official contact with the House of Austria.

Rudolf II was crowned King of the Romans in 1575 and German Emperor in 1576, a privileged situation that did not temper his inclination for the study of the occult arts, but rather affirmed him in these tendencies, since he used his enormous power in order to surround himself with the wisest men of the epoch, as we have already said in the introduction.

One of his first steps as Emperor was to initiate negotiations with his uncle Philip II of Spain in order to obtain the talking stone, an impossible task due to the many difficulties that had to be overcome: first, Philip II, a fanatical Catholic, was not at all enthusiastic about the idea of claiming from the Viceroy of Mexico a “pagan cult object”; second, the missionary Pedro de Gante had died in 1572, four years earlier, and among his belongings from América was not the famous stone; third, an obstacle of which Rudolf II had no idea but that, to his misfortune, he would soon become aware, were the Druids, always lurking in order to destroy the Hyperborean tradition.

The solution envisioned by Rudolf II consisted in obtaining a safe-conduct from his uncle so that a trusted person could travel to Mexico to seek the stone. But this person would have to possess such an authority that would allow him to overcome any obstacle, even if it was imposed by the ecclesiastical authorities. Convinced that in this way he would achieve his goals, he took action.

It took Rudolf II two years to get Philip II to accept his plan, and another year to get Pope Gregory XIII to authorize an envoy of the Emperor of Germany and King of the Romans to “perform a general review at the Convent of San Francisco in Mexico City, West Indies.” Be that as it may, sparing unnecessary details for our account, what is certain is that in 1579 one of Rudolf II’s nephews, Frédéric de Bourgogne, 22 years old, left for Mexico, duly instructed on the object to be sought and the prudence that the mission required. The young Frédéric de Bourgogne quickly found the talking stone, forgotten for years in the chest of Pedro de Gante, then preparing to immediately return to Prague.

Here the mysterious events that we were mentioning as the third difficulty begin to occur: the Druids, infiltrated among the missionaries, do not take long in finding out that the talking stone was about to leave for Europe, and decide to prevent it. Thus it is that “some strangers” attack Frederick in his room the day before embarking, and flee leaving him for dead, after taking all of his baggage. But, incredibly, he survives despite being almost strangled with a cassock fascia; and the most miraculous thing is that the thieves, who were undoubtedly looking for the talking stone, did not count on Frederick having it on him, and did not check him.

And yet it had occurred that way. The famous stone, placed inside of a bag of fine peccary leather, was hidden in the clothes that he was wearing when he was attacked. The result? Frederick was unable to return, but sent word to Rudolf II who, upon receiving it, began to suspect that his idea was not so good and to fear for his nephew's life.

After several weeks in bed, during which he did not part from the coveted stone for even a second, Frédéric de Bourgogne was once again willing to travel and so it was that in the first days of January 1580 he embarked on the frigate "*Castilian*" in charge of relieving the military personnel. This ship, after making stopovers in Cuba and Venezuela, was leaving for Spain.

But it was written that Frédéric de Bourgogne would never return to beautiful Prague, confirming that which Rudolf II was fearing: a large-scale conspiracy had been set up in order to prevent the transport of the talking stone. Thus it happened that the frigate, after sailing from Cuba and heading for Venezuela, was attacked two days later by a fleet of English corsairs who were "mysteriously" seeming to know the route that the ship would take.

After a tenacious pursuit, with winds that were strangely changing direction, favoring the pirates, and after losing the mainmast, the frigate was finally attacked by two fast corvettes, and a bloody melee broke out on deck. The raging Spaniards, outnumbered, succumbed to an enemy that was showing no mercy and fighting with unheard-of ferocity. No prisoners were taken; and only a Catalan sailor, who fell into the water and drifted for days clinging to a piece of mast until the tide deposited him on a Costa Rican beach, was able to survive. The captain ship, which first carried out the attack, was the *Golden Hind*, commanded by *Francis Drake*, Elizabeth I's "favorite" pirate, who personally executed Frédéric de Bourgogne by slashing his throat with his sword.

The corsairs knew exactly what to look for because, after finishing off all the crew members and carrying out an exhaustive search, which allowed them to find the bag with the talking stone on Frederick's cadaver, they proceeded to set fire to the *Castilian* and flee. With this shipwreck, the adventure encouraged by Rudolf II tragically concluded.

The German Emperor, upon learning that the *Castilian* had disappeared without a trace, fell into a state of depression so

acute that he was only able to precariously overcome it a few months later, but from which he never fully recovered.

However, the history of the talking stone was not ending here for Rudolf II; it could be said that it was just beginning. Because the Aztec stone that Francis Drake's "informants" had assured was extremely valuable, and that he hastened to send to Elizabeth I, was not to the Queen's liking. But respecting the news that they were attributing great value to it, and intrigued by the unusual brilliance that one of its sides was giving off, she decided to consult *Dr. John Dee*, an expert in optics and one of the most important sages of the kingdom, about the Aztec stone.

As we will see, this is another miracle that saved Princess Papan's stone mirror; for John Dee was the best person in England to receive it, and into his hands the *Catena Aurea* led it. But England is a land of Druids; would the talking stone be safe, even in the hands of Dr. John Dee? And more importantly, would it be possible to use it again, as did the ill-fated Aztec princess, in order to establish that much-needed dialogue between man and the divine Hyperboreans? We will leave the answers pending, given that they will become evident as the story unfolds.

While these events were occurring, one of the English friends of Emperor Rudolf II learned of the frigate's fate and the assassination of Frédéric de Bourgogne. This friend, a young count, sent a letter to Rudolf II through Flanders, a country that the English were supporting in their attempt to gain independence from Spain. When the esoteric Emperor learned of the fate of Frédéric de Bourgogne and the destiny of the talking stone, his indignation and grief knew no bounds. But what to do? Philip II Habsburg was waging a war against England that was becoming increasingly disastrous for Spain. And without the triumph of the Spanish arms it would not even be possible to dream of recovering a spoil taken by the English from a Spanish ship.

There was only the remote possibility of initiating a secret negotiation. But this alternative was very dangerous, because of how badly Philip II could take it, in case he found out. And yet there was no other alternative for Rudolf II, who, on the other hand, had already become aware of the strange things that were happening every time that he was attempting to get hold of the talking stone.

Thus begins a secret negotiation between Rudolf II and Elizabeth I, which would last four years, during which the Emperor offered everything from gold to alchemist formulas or Dürer paintings, and the astute Queen was increasingly reinforced in the conviction that some arcane secret was making the rustic black stone mirror so valuable.

Elizabeth I had no intention of parting with the stone and was only negotiating in the hope of obtaining additional information from the impatient German Emperor. But this information was soon not necessary; for Dr. John Dee solved the mystery posed by the talking stone and penetrated into its mystery, affirming one fine day that by means of the “stone mirror” one could “see and speak with angels.” This affirmation and the revelations that he made later, signified the ruin of John Dee and, in a certain way, also that of Rudolf II.

Dr. John Dee and the Stone Transducers



Let us leave the stone mirror of Princess Papan for a moment and stop at our principal personage: who was John Dee? Undoubtedly, a sage of the epoch, but also more than that. Born in England in 1527, he studied at *Cambridge*, was the writer of the “Mathematical Preface” to Henry Billingsley’s English translation of Euclid’s *Elements*, a mathematician, a specialist in optics, document encryption, etc.

He was representing, in Elizabeth I’s England, which was ascending as an imperial potency of the sixteenth century, one of those brilliantly multifaceted Renaissance spirits that had their universal prototype in the Italian *Cinquecento* with Leonardo. But whatever is said to praise the virtues of Dr. John Dee, it can add little to his main title: Hyperborean. For John Dee was an *awakened Virya*, mutated into an immortal Siddha after his “disappearance” occurred in 1608. His incredible life, especially the period from 1563 to 1608, is an example of the dangers to which a Hyperborean Virya is exposed when he intrepidly, in order to fulfill a “strategic objective” in the cosmic war, reveals his superior condition and exposes himself to the attacks of the Synarchy.

John Dee was secretly working, for 17 years, on the reconstruction of the legendary “language of the birds,” based on a work obtained in Antwerp, which we will relate later in the chapter titled “Steganographia of Trithemius, a Hyperborean Work.” From these investigations he had successfully achieved the mastery of a primordial language that would make it possible to re-establish dialogue with the “angels,”—Hyperborean Siddhas—in the manner of the ancient oracles, for which he only needed a “magic stone” or “omphalos.” John Dee knew that with the survivors of Atlantis (the “last” Atlantis, sunk 12,000 years ago and cited by Plato) a certain number of those stones that the Hyperborean Siddhas were using in their “magical” operations on the concrete world had been saved. These stones later made it possible, when the Hyperborean Siddhas withdrew to Agartha and the Siddhas of the Dark Side ruled Atlantis, to communicate with them by serving as an “oracle,” the only application that was permitted to give to

the sacred stones. When then ensued the cataclysm, provoked by the Siddhas of the Dark Side, some of the magical stones were preserved by the survivors.

But such magic stones were actually *transducers* of psychophysical energy constructed thanks to the advanced lithic technology that Atlantis was possessing; i.e., they were *machines* to interfere in the *psychoïd Collective Unconscious* in both directions: obtaining information or influencing it in order to operate on the laws of nature. We will return to the functioning of the transducers when studying the Psychosocial Strategy of the *Hz*; but for now let us say that in order to “operate,” these stone devices require the presence of a human being who establishes a “sympathetic bond” with them. This means that certain magnitudes in the acting energies must be properly *adjusted* in order to achieve the *triple resonance* between the human being, the stone, and the Earth (or the “telluric energies” of the place in which the transducer stone is located).

In Atlantis, the human-being operator of the stone was a virgin priestess, this latter condition being imposed on certain biological restrictions in order to achieve perfect harmony in the psychophysical force fields of the human body and, of course, this choice of virgin maidens had nothing to do with moral premises of any type.

The act was converted into a tradition by the survivors who had “forgotten” the meaning of it, led them to form the castes of virgin priestesses, so common among the Incas, Aztecs, Trojans, Greeks, Romans, Hindus, Egyptians, etc. The survivors of the purest Hyperborean lineage, that is, those who took refuge in northern Europe, were calling them “virgins of Fâsta,” as the Frisian manuscript *Oera Linda* tells; and in a less pure tradition, the Romans, for example, transformed them into “Vestal virgins.” But they were also called, after the catastrophe, “Virgins of the Sun,” Priestesses of Mithra, Daughters of Agni, etc.

In spite of this insistence (by lay survivors or those who had lost the knowledge of their ancestors) on the female figure as priestess, or Pythian keeper of the Oracle, the reality is that there is no physical law that prohibits the masculine sex from operating with the stone transducers. There are, it is true, biological restrictions that must be overcome when tuning a transducer stone; and these difficulties are compounded if the officiant is of the masculine sex; but it is not impossible, or

even difficult, to operate the stones if the man is properly prepared. The Druids were well aware of these traditions, for during their exhibitions of amazing power over the forces of nature, they were making use of a stone transducer known as a “serpent’s egg,” an allegorical name utilized in order to designate the fact that, just as, in the serpent’s egg, the evolution of the reptile can be observed through the thin membrane that is the “shell,” so too when looking at the stone a strange *movement* can be observed *in its interior*. Such a “movement” is nothing other than the visible effect of the phenomenon of energy transduction described by some as “vaporous luminescence” and by others as “glowing serpents”; that is, in the first case a sort of “static charge of ions” and in the second, simple “voltaic arcs” of telluric energy.

The Roman scholar Pliny the Elder, when recounting, in the work *Naturalis Historia*, his experiences with the Druids, describes one of such transducers: “The egg is called *anguinum*. The Druids say that hissing serpents throw this up into the air, and that it must be caught with a cloak, and not allowed to touch the ground; and that one must instantly take to flight on horseback, as the serpents will pursue until some stream cuts them off. It may be tested, they say, by seeing if it floats against the stream of a river.”

To this commentary by Pliny, Robert Scrutton responds as follows: “While this superficially seeming hocus-pocus was enough to throw the literal-minded Pliny off the track, it can easily be seen as a genuine description of the ‘charging’ of a transducer. The wily Druids must have realized that Pliny would not understand – and so told him the truth. Hissing serpents, or telluric currents, in charging the object, made it float in the air. There are many references to the levitation of such transducers. Now as the transducer held a static charge over its surface, if it was caught with the bare hands, it would quite likely discharge painfully through the person who grasped it. It would also discharge if allowed to touch the ground – hence the reason for catching it in a non-conducting material, such as a woolen cloak. Nor could a transducer cross the running waters of a stream, whether that stream was below ground or on the surface. It would be held quivering in the air, like the muscles in the wrists of a dowser, by the telluric radiations thrown off by the current. It floated because it was

hollow, but would be held in one spot by telluric energy, like an iron particle in a magnetic field.

“Pliny’s account continues, ‘But as it is the way of the magicians to cast a cunning veil about their frauds, they pretend that these eggs can only be taken [charged] on a certain day of the moon, as though it rested with mankind to make the moon and the serpents accord at the moment of operation.’

“It becomes even more obvious here that Pliny was taking everything literally. He could not see how men could cause serpents or snakes to lay their eggs at a particular lunar phase. In fact the serpents were, of course, the telluric energy which, as we have seen, varies with the phases of the moon.

“Pliny goes on: ‘I have seen one of these eggs; it was round, and about as large as a smallish apple; the shell was cartilaginous, and pocked like the arms of polypus. The Druids esteem it highly. It is said to ensure success in lawsuits and a favorable reception with princes; but this is false, because a man of the Vocontii, who was also a Roman knight, kept one of these eggs in his bosom during a trial, and was put to death by the Emperor Claudius.’

“Naturally the transducer did not ‘work’ for the Roman knight – it would not have been attuned to his life rhythms and therefore could not have helped him to improve his reasoning faculties and eloquence. He probably stole it from a Druid.”⁹

The Druids were commonly using the stone transducers in their “magical” practices and were very careful to prevent anyone else from possessing them. This is how, resorting to any procedure, from deception, intrigue, or spells, to the uprising of revolted peoples, they were “recovering” the magical stones that the surviving Atlanteans had preserved. The fall of Atlantis was produced mainly, as Plato recounts in *Critias*, “by the racial sin of the mixture of bloods,” i.e., by the “blood confusion” and loss of the Minne. The survivors, in different degrees of confusion, remain isolated among themselves, separated by thousands of kilometers, their Atlantean origin and their cosmic Hyperborean ancestors are “forgotten.” They form small tribes or groups that will later give rise to many of the peoples that have reached our times. The most fortunate are those

9. *Secrets of Lost Atland: Sequel to the “The Other Atlantis,”* Robert Scrutton, 1978; pp. 164–65.

who have managed to save a “virgin priestess” or a “mother,” and with her sacred stone found various cults and oracles, preserving, increasingly degraded in the oral tradition, some remnants of the ancient wisdom.

The attack from the Synarchy will be directed against them from its hidden center *Chang Shambhala* in order to “recover” the talking stones, and many of the bloodiest wars that History records have been waged with the hidden purpose of destroying the oracles and stealing the sacred stone.

The Druids were those who led the Gaulish expedition of Brennus, in 279 BC, to the Greek temple of Delphi in order to steal the *Omphalos*, the stone that was marking the “center of the world” and was enabling the Pythia to communicate with Apollo and the Hyperboreans. And those who sacked the simple Etruscan temples and stole their sacred stones were the Celts, led by the Druids. The same occurred to the Iberians and Ligurians (with perhaps the exception of the Iberian “stone lamp” that Belicena Villca was mentioning in her letter, but this remains to be confirmed, Neffe Arturo) and by infinite intrigues, the Visigothic kings, who had the misfortune of governing Celtic peoples infected by Druids, also lost theirs.

The complete list of the bloodthirsty persecutions undertaken by the Druids would be almost infinite and impossible to transcribe here, but it is worth raising some questions about certain significant facts: was it not the Celts who conquered the Américas and destroyed its civilizations governed by castes of Atlantean Hyperborean lineage? And did they not do it incited by Catholic priests, really infiltrated Druids, who justified the most dreadful crimes shielded by myths such as the supposed “paganism” of the “indigenes” and the need to “civilize” and “evangelize” such “savages”? And together with Celts and Druids, were not a great number of first-in-line Jews traveling to America, following the example of Christopher Columbus, whose Jewish affiliation today no one can seriously doubt? In the “discovery” and “civilization” of America there was a sinister synarchic conspiracy of which we will speak later on, when dealing with the question of the Gral.

In order to finish up this part of the story, we must keep in mind that when Queen Elizabeth I gave the magic mirror to John Dee for his study, he was perfectly aware of its properties of transduction.

Steganography of Trithemius, a Hyperborean Work



We have already mentioned the Catholic Queen Mary of England, wife of Philip II of Spain. During her reign, Dr. John Dee was imprisoned for conspiring with the Protestant party. He was released from prison in 1558 by Queen Elizabeth I, who later entrusted him with several diplomatic missions on the continent, an occasion that the sage was taking advantage of in order to search for manuscripts of Alchemy, the collecting of which he was an enthusiastic aficionado.

In 1563, he was fulfilling a secret mission in the Spanish Netherlands, related to the independence movement that England was encouraging there, when he learned that an old Jew was in possession of some very valuable manuscripts that he would part with for a large sum of money.

He was a Portuguese Jew named *Isaac Laquedem* who had arrived with his entire family in Flanders after the mass expulsion decreed in 1497 by King Manuel I, the Fortunate. The majority of his brothers of race, and even his own family, continued their journey to Amsterdam, a city that in a short time would be known as *The New Jerusalem*; but Isaac remained many years in Brussels. This mercy was granted to him thanks to his status as a scholarly librarian, for by 1500, when his family left Lisbon, he was the archivist of King John II's treasury. This profession—and the help of the many “converted” Jews who were occupying high positions in the Flemish court of Philip the Fair—allowed him to take up a position as Royal Librarian in Brussels, after passing to Marrano status “for a time.”

His zeal and evident capacity made him famous and highly regarded in Flanders, which is why he was permitted to stay for more than half a century. On the date at which John Dee arrived in Antwerp, *Isaac Laquedem* was over eighty years old but was still at the head of the Royal Library. He was now living in the ghetto—in that Calvinist and independentist Flanders of the sixteenth century. Being a Jew was no longer representing a major danger, so Isaac soon returned to his Levitical customs and vestments—and he had “discreetly” put up for sale certain manuscripts of “his property.” John Dee was realiz-

ing the risk that an acquisition of this nature was entailing, since such manuscripts were certain to be stolen from the royal archives; unless the Hebrew attempted to swindle him with some forgery, a practice that was customarily carried out on the unwary or “alchemist apprentices.” But John Dee was an expert and would not be easily fooled.

However, distrust invaded him when he found himself in front of the old, rabbinical-looking librarian. He was looking incredibly old, an impression accentuated by his shabby black frock coat and an old top hat from which were emerging two tired eyes and a bushy curly beard. He expressed that he needed the money in order to retire and live out his last years with his relatives who were living in Holland, since his passion for the study of the occult sciences had so far consumed all of his earnings. When realizing that his explanations were only increasing the doubts of his interlocutor, he decided to be more explicit and said:

“I see, Sir, that you are a very wary person. You are right because these times are very hard and you could be abused. But this is not the case with me. What I have told you is true; and if I agree to sell you so great a treasure as that which I offer you, it is due to the fact that it is in my interest to make the transaction with a Briton.”

This allusion to his foreign status further affirmed John Dee’s conviction that the manuscripts were stolen. The old man, heedless to the effect of his words, was continuing to speak:

“I will tell you a story, Sir, which will perhaps dispel your doubts. Many years ago, more than forty, a German scholar named *Heinrich Cornelius Agrippa von Nettesheim* was arrested and imprisoned in Brussels. A conspiracy had been hatched against him in 1531 because until then he had enjoyed the protection of the regent Margaret Habsburg of Austria, who died in 1530, daughter of ‘the Last Knight,’ Emperor Maximilian I. Thus it was that in 1531, thanks to the many denunciations that Franciscans and Dominicans made to Charles V, but especially through the intervention of our traditionally strong rabbis in Holland, that Cornelius Agrippa was sent to prison. I played a miserable role in that conspiracy, which I do not regret, because my rabbi was affirming that we were before the most terrible sorcerer, a declared enemy of the true religion, who had to be destroyed without mercy.

“When Agrippa fell, I had the mission of requisitioning his numerous books and manuscripts for confiscation in favor of the Royal Library, but secretly I received the order to burn them all. It was here where I committed the only sin that torments me ever since,” the old Jew was now looking strangely bright-eyed.

He continued speaking in this manner:

“I did not fulfill what was ordered; and not only did I preserve those blasphemous writings, but I vainly attempted to decipher them throughout all these years. You must know, Sir, that I am an expert Kabbalist, a disciple of Johann Reuchlin, and that all my science has not been able to do anything against the mysterious coded writing of Agrippa’s manuscripts. That is why I am selling them to you, because I need your money and because I trust that you, being a simple *Goy*, will not be able to decipher them. But I tell you this because I do not wish to deceive you.”

It was seeming as if the old man sought some excuse for not parting with the writings. But John Dee considered that this attitude was corresponding to a ruse by the astute Jew in order to create a veil of mystery that would enable him to raise the price or haggle over it, as is customary among those of his race.

“Tell me,” said John Dee. “How is it possible that, upon being released, Agrippa has not claimed that which was belonging to him?”

“Oh!” the Jew exclaimed stupefied. “He-he-he. You do not understand, Sir. Agrippa was treated with certain drugs in prison. Terrible drugs, that destroy one’s sanity. Your compatriots did that, Sir, the Irish priests who came especially to interrogate Agrippa. When they left him, he was completely mad. And he was until he died in 1535. He should not have meddled with *them*, no, Sir!”

John Dee realized that the Jew was raving, for, with his eyes dilated with terror, he was continuing to speak, no longer noticing his interlocutor.

“We are powerful but so are the Filí! He-he-he. Oh, yes! *They* are powerful and terribly relentless. They tortured Agrippa’s mind until driving him insane by using their drug that *opens the door of the soul...*”

Isaac Laquedem was now presenting a lamentable appearance. His eyes were bulging and a white foam was running down the corners of his mouth until soaking his rabbinic

beard. The wise Englishman was looking at him in silence, with a compassionate expression. A few minutes later, already recovered, the old man made, without much conviction, an apology.

“You must pardon me, Sir. The secret kept all these years must have upset me and I have spoken without thinking about what I was saying,” he adjusted his hat and clarifying his voice, he now demanded in an imperative tone, “Well, are you willing to take them or not? Answer me at this moment because I feel that my health worsens and I believe that tomorrow I will undertake a journey to the house of my brothers who live in Amsterdam.”

John Dee, who was not believing anything of what he had heard, was fearing being the victim of a scam; for something that he was unable to discern was giving him the impression that the Jew was not really looking to sell. He was discarding that fear was the motive, and besides, fear of whom? No one knew what he had to sell. And this absurd allusion to the *Filí*? John Dee knew, like any educated Englishman, a thousand stories about the Filí of Ireland, Scotland, and Wales. And all of them were speaking well of the good-natured Druids, Celtic mages who guided and helped them when the Saxons, Angles, Norwegians, Swedes, Danes, Normans, and Romans tried to destroy them. What was that Jew’s allusion meaning? Surely, he was delirious.

“Well, Mr. Laquedem, we will soon see if we have a deal,” affirmed John Dee, “but I must warn you that I possess all the works of Cornelius Agrippa, although an original manuscript of *Occulta Philosophia* might interest me. What I do not fully understand is your comment that so important a work was written in code. According to my reports, Agrippa never wrote a book completely in code. In 1517, he wrote a treatise on the Hebrew Kabbalah and how to decipher codes, but he himself was not using any system in order to write secretly, or...?”

“He-he-he,” the old Hebrew’s laughter sounded like a hen’s cluck. “I see that you know the subject of which I spoke from the beginning. Yes, Sir, you are right in supposing that the sage of Cologne was not writing in code. But the work that I offer you is not by Agrippa, but by a sorcerer a thousand times more powerful than Cornelius Agrippa. It is eight manuscript books

by Abbot Trithemius,¹⁰ which contain the most terrible set of secrets ever written since the angel *Raziel* gave his book to Adam. May Raziel and Michael plunge Trithemius into *Gehenna!*”

Isaac Laquedem had finally said something that piqued John Dee’s interest. Like all the alchemists of his epoch, he was aware of Abbot Trithemius’ famous work, which was believed lost since 1516. The story that the Jew was telling was now becoming convincing; and John Dee thought that it was worth taking the risk of buying a forgery even if there was only a one in a thousand chance that the work was authentic.

After haggling for a few minutes, the deal was sealed: ten pounds of gold for a trunk of manuscripts. Soon the wise Englishman would realize that he had made an extremely advantageous transaction; for the acquisition, if it were possible to appraise it for its spiritual value, was surely worth thousands of times the price paid.

Agrippa’s trunk was containing manuscripts of the majority of his works, although many were not by his own hand but made by skilled copyists, among them the book in which he exalted feminine beauty and dedicated it to the regent Margarita, his protector, in 1517. There were also texts by other authors on alchemy, astrology, and hermetic science. But the mystery was undoubtedly the fine leather package containing the eight handwritten tomes of *Trithemius’ Steganographia* and a letter from Trithemius to Agrippa.

Johann Heidenberg, known by his pseudonym *Trithemius*, was born in 1462 in the town of *Tritenheim*, Rhineland-Palatinate. During his youth he belonged to a Secret Society called *Sodalitas Celtica* (Celtic Sodality) to which were belonging some Rhenish occultists of Celtic origin like Conrad Pickel (Meissel), nicknamed *Celtis Protucius* (“the first of the Celts,” a title that clearly reveals his Druidic affiliation). In it were also pure Germans like one Rodolphus “Agricola” Huesmann, Jo-

10. “great and extremely arduous work devoted to the marvelous invention of steganography, to be divided into eight books, of which I have completed the first and second books. The third, however, I have been persuaded by various considerations to leave uncompleted, and to keep all the remaining books buried from view to the present day. For the labor of this task is great, but the return, so it seems, is small. Let it, therefore, remain unfinished as it lies, until its utility may persuade me to do otherwise.” Trithemius to Sicamber, Würzburg, 31 August 1507, *Epist. fam.* II, no. 51, in Freher, *Op. hist.*, II, 563, cited in *The Abbot Trithemius: The Renaissance of Monastic Humanism*, Noel. L. Brann, 1981; p. 91.

hann von Dalberg, Joachim Camerarius; famous professors like Jakob Wimpfeling, and even a “renegade” Jew, Paolo Riccio, who was teaching Kabbalah to the members of the society.

If Trithemius noticed the danger to which an enlightened Hyperborean Spirit, like his, was exposed in a *Celtic Sodality* infected by Jews and Druids, it is something that we must doubt, since his imprudences later led him to ruin. In any case, Trithemius enters the Benedictine Order at the age of 20. This order alone merits a separate study, so we leave this task for another occasion, and consider now that in the Abbey of *Saint Martin* at *Sponheim*, at the age of 23, Trithemius will be appointed Abbot. There he begins his famous—and tragic—task of forming the most complete manuscript library in Germany. He also writes quite a lot; but the most important work for our story is, naturally, his *Steganographia*.

In 1499, due to a letter that Trithemius foolishly sent to the Carmelite *Arnold Bostius* and that reached its destination when the latter had died, the existence of *Steganographia* was made public. In the letter, a copy of which Trithemius himself published years later in his book *Polygraphia*, are described the portents that could be achieved if the eight tomes were studied and the rules followed: immediate mastery of any language on Earth; mastery of cryptography in any language, so perfectly that no one who was not in on the secret could decipher; mastery of techniques in order to telepathically direct peoples; mastery of techniques of communication, at any distance, by means of certain *lithic devices*; mastery of techniques in order to foresee future events; mastery of Alchemy and the possibility of collectively taking advantage of *transmutations*; mastery of life, the possibility of creating the *homunculus*; mastery of the whole science of Steganography by means of an infallible *self-initiatic* technique (according to Trithemius), etc., etc.

Anyone can imagine what occurred when the contents of *Steganographia* became known: a sinister conspiracy that began with the rebellion of the Benedictine monks, who were belonging to his abbey in *Sponheim*, and culminated with the papal prohibition to publish *Steganographia* under penalty of excommunication. In 1505, he had to renounce Sponheim and his library, and in 1506 he submissively left for the Abbey of *Saint James* in *Würzburg*.

From where or from whom did Trithemius obtain the formidable knowledge poured into *Steganographia*?

He tells it in the *Polygraphia*, a book he wrote in Würzburg between 1506 and 1508: “some angels” reveal to him *how to obtain knowledge on his own*.

For us it is clear. Trithemius, awakened Virya, is trained by the Hyperborean Siddhas on how *to read* the books of the *Nine Unknown Men*. Of those nine books, perhaps for the first time in many centuries, Trithemius summarized and copied the science of eight of them in his *Steganographia*.

We know of the existence of the Society of the Nine Unknown Men mainly from the account that King *Ashoka* of India gave of his contact with it in 273 BC. These Nine Unknown Men would have the mission of “watching over” so that humanity makes “good use” of intelligence. In order to comply with their beneficent mission, these “Holy Guardians” have nine books, each one with their own, which would have the unusual property of not being *finished*, but that only new wisdom is constantly *being written* in them.

Since *Ashoka*, much has been said, with terror and admiration, about this Secret Society in the countries and kingdoms of Asia, but only in the nineteenth century was its existence divulged in the West, especially through the work of the French barrister *Louis Jacolliot* and the English author *Talbot Mundy*. However, in spite of the “unknown” character of its members, the Society of Nine has been acting in the West since the Middle Ages with interventions of different types and the “sending” of “adepts” in order to fulfill obscurantist missions. The famous “Pope of the year one thousand,” Sylvester II “the Druid,” had been at their service, to cite one example among hundreds.

There is also a relationship between the Society of Nine and the matter of the “Kingdom of Prester John,” which we will return to in another chapter. Lastly, let us note that the power and impunity of this Secret Society of “Unknown Men” can evidently impression some weak spirits and in fact succeeds in many cases, according to synarchic tactics.

We do not form part of the legion of dupes who serve the Nine “Unknown Men” and if one considers that their lair is called Chang Shambhala, surely by now they will be more “known” to all. For these Nine form the High Council of the most sinister *enforcement* organization possessed by the Synarchy, the “commandos” of which are lately known as *Men In Black* (MIB).

Their magic books? They are stone (i.e., “solid-state”) transducers tuned to resonate with the so-called “records” or “memories” of the Earth, i.e., with the psychoid Collective Unconscious of the living planet. They were stolen from Atlantis by the Siddhas of the Dark Side as part of a larger plunder, the patrimony of all humanity, now zealously guarded by the MIB. By means of such lithic instruments, books in a certain sense, one can obtain immense knowledge or penetrate into many terrible secrets, the most frightening of which reveals the origin of the Hyperborean man or Virya on Earth, his spiritual enchainment to matter and the deception, the Great Deception, to which he is subjected by making him believe that he has sinned in that primordial time in which he was inhabiting a lost paradise. *The only paradise, the only Golden Age that the Viryas have ever known, is called Thule, and it has nothing to do with the Creator of the Solar System, nor is it in this material universe.*

The original Thule is the Fatherland of the Spirit and can only be *sensed* with the conquest of the blood Minne. Only the Vrîl enables one to *remember it*; but this *center* is the exclusive patrimony of the Siddhas; and in order to possess it, the Virya must transmute himself into an immortal Hyperborean. But, in any case, the most marvelous thing that the *memory* of primordial Thule entails is that whoever wishes *to see it*, and even to return to it, must *create it* with the absolute *possibility* that the Siddha possesses. And this is the greatest mystery of the Vrîl.

Who prevents the Viryas from returning, who has plunged them into matter, who has created the Great Deception, who has horribly calumniated Khristos Lúçifer and covered him with blasphemies? The Demiurge Jehovah Satan. *That is why the ninth book is that which no one opens*: because it permits one to see the “face” of the Demiurge, “His Work,” and “Himself,” pantheistically diffused in “Creation.” And, it is assured, no one who is incarnated could contemplate His Face and continue living. And not even the dead would have peace, whoever has descended into such an infernal blackness of the Spirit. Whoever opens the ninth book risks perpetual madness, a scream of eternal terror, a tragic, horrifying, unspeakable anguish, without consolation or relief.

But let us not fear for Trithemius: he did not open the ninth book. However, his “sin” was great, for he had laid his gaze,

that clean spiritual gaze of the Hyperboreans before which the synarchs tremble with hatred, on the other books, reading in them a knowledge zealously hidden for thousands of years. And such an audacity could not be pardoned. For the time being, it is taken out of circulation at Würzburg; but that is not enough: it is necessary to destroy *Steganographia* and the copies of some parts of it that Trithemius permitted to make while he was at Sponheim. An enormous number of sinister personages, among them many members of the Benedictine Order, the same to which Trithemius belongs, devoted themselves with great care to this task. The Prior of Würzburg is attacked from all angles, a negative strategic situation that, however, has the advantage of allowing to identify the enemy. Consequently, it does not take him long to realize that the Benedictine Order is an order of Druids; and he notices, too late, many dangers that in his youth, when belonging to the *Sodalitas Celtica*, he had not suspected.

But the wise Prior of Würzburg is now a Hyperborean Siddha and is, therefore, incorporated into the Cosmic War; i.e., he has comprehended the Hyperborean Strategy and is qualified for elaborating the tactics to counteract the synarchic offensive. The first thing in any strategy is to “set the Objectives”; and that is why his main slogan was “to defend *Steganographia* from the inquisitorial bonfire and to review the way in which the knowledge contained in the work is perpetuated for its future use for the benefit of humanity.” To fulfill these goals, he decides to call other Hyperborean Viryas to his aid using, in order to locate them, his knowledge of the Hyperborean Mystique—a subject that we will see developed when studying the Psychosocial Strategy—seeking to produce in them the *charismatic bond*.

The first who comes is the young Agrippa von Nettesheim, 23 years old, a Hyperborean Virya eager to collaborate with Trithemius, possessing a truly superior intellectual preparation. It is the year 1510 and Trithemius senses that he has little time left to live. With this conviction, he decides to accelerate things and commissions Agrippa to carry out a work on Occult Philosophy, not without first training him in cryptography and supplying him with the “messages” that he should insert in it, destined for other Hyperborean Viryas of the “*Catena Aurea*.” This is the reality that John Dee was unaware of in Agrippa’s work, even though he himself was an expert in cryptography,

because he did not know the keys necessary in order to decipher the text during the epoch in which he read it and translated it into English.

In 1515, Trithemius decided that the Virya best suited for bequeathing *Steganographia* to was Agrippa, which constitutes a new imprudence; for the sage of Cologne, after his *Occulta Philosophia* in which prologue he was praising Trithemius and publishes a letter of the latter, was equally in evidence before the Synarchy.

Perhaps a better choice would have been the young *Theophrastus*, who since 1513 had been receiving instruction from the Prior of Würzburg. But Theophrastus, whose real name was *Philippus Aureolus Theophrastus Bombastus von Hohenheim*, or simply *Paracelsus*, was only 20 years old in 1515 and, although he was an awakened Virya as capable as Agrippa, it did not seem to Trithemius that *Steganographia* was safe in his hands. We already know of *Cornelius Agrippa's* end at the hands of the Druids, Jews, and Catholics. That of Theophrastus Paracelsus was no better, for many years after these events that we are narrating, in 1541, being very famous as a physician and alchemist, he was murdered in Salzburg by “unknown men” who carefully rummaged through his belongings.

Theophrastus Paracelsus was executed by agents of the Synarchy in 1541; and one wonders whether Trithemius might have foreseen his sad end by using his many esoteric resources. If so, then the choice of Agrippa as the depository of *Steganographia* must be considered correct, and the “imprudence” of Trithemius would not be anything more than a very clever Hyperborean tactic. We believe that Trithemius found a way to “divert” the attention of the Synarchy to Theophrastus Paracelsus by allowing, in a mysterious way, *Steganographia* to “reach” John Dee. The history of Theophrastus is very long and interesting, but we cannot dwell on it more than what is essential. Let us recall only that after the death of Trithemius, in 1516, a tenacious persecution was unleashed against Theophrastus that many times deprived him of his professorships and led to the prohibition of his books, but which, however, never managed to be based on a formal accusation that culminated in them being burned. His enemies had no choice but to assassinate him without having found what they were supposing was in his possession.

Be that as it may, what is certain is that the wise Prior of Würzburg makes a move that would ultimately save *Steganographia*: he made a secret copy to send to Agrippa, and gave the original manuscript to the Elector of the Palatinate, Philip, in order to keep it “until the Holy See issues a definitive decision on the work.” A few years later, this work was burned by Count Frederick II of the Palatinate, Philip’s son, at the request of the Dominican bishop, thus closing the official chapter of the history of *Steganographia*, considered definitively lost after that holy incineration.

In Agrippa’s trunk, which Dr. John Dee acquired, was the secret copy of *Steganographia* and a letter from Trithemius where, after narrating part of the misfortunes here exposed, he was entreating the sage of Cologne to keep the manuscripts in the greatest secrecy while the “Superiors” were sending whoever was deserving to have them. He was also forbidding Agrippa, reminding him of a certain oath taken in Würzburg, to make other copies of the writing. These instructions were happily respected by Agrippa and, if we think that for his own work *Occulta Philosophia* he was persecuted, imprisoned, and finally reduced to madness, we can wonder what his enemies would have done if they had known that he was in possession of a copy of *Steganographia*. But things would happen differently: the Catena Aurea had charismatically bonded the English Virya with the work of Trithemius, and its reading would enable him to rise to the highest peaks of the Hyperborean Wisdom. And these two great men, Trithemius and John Dee, separated by a few years in history, lay the foundations of the spiritual movement that five hundred years later will provoke a new leap in humanity. A *mutant leap* that occurs every seven hundred years, the previous one being that which, in the thirteenth century, Frederick II Hohenstaufen and the Cathars of the French Languedoc impulsed, but this time it will be definitive and will put an end to the Kaly Yuga. For then the peoples of the Earth will have the immense joy of having the Führer of the Germans, an immortal Siddha who will wage the Total War against the Synarchy, after which will come the *Hyperborean millennium* and the *Parousia of Khristos Lúcífer*. The Führer will once again open the eyes of the Virya so that he may find the path of return and transit it with weapons in hand, combating face-to-face against the vile enemy, Jehovah Satan.

Elementary Notions on the Hyperborean Wisdom

I.



It is possible that when becoming aware of the significant details of the lives of the Viryas who intervened in the Secret History of the Thulegesellschaft, just as we have presented them up to now, going back to the sixteenth century and even further, *the “nexus” that unites them may not be clearly visualized.* That is to say, how do they manage to connect? What guides them? Does it occur due to the fact that the Viryas possess a common element? Will this common element be something cultural, like esoteric knowledge, for example? It is a fact that all the Viryas were esoterics: does it not indicate that they were sharing a Secret Doctrine and that a master-disciple relationship, related to such a Secret Doctrine, would be the sought-after nexus? All this *reasoning* constitutes an error; and as it is a dangerous error, we will attempt to dispel it before proceeding further with the story of John Dee and Princess Papan’s mirror.

There is a generalized attitude that consists in seeking, by means of the rationalistic recourse of *comparing* the work and the thought of the Viryas, a supposed Secret Doctrine of which *all* ought to have participated. The results of such *unifying* attempts cannot be more absurd, especially because they *force* facts for the purpose of *justifying* dogmatic conclusions postulated a priori, i.e., preconceived.

But the truth is that such a “Secret Doctrine” *does not exist*, nor does such an esotericism common to the Viryas, because all of them are “esoterics,” individually. This affirmation may seem a paradox, but we will soon see that it is not so.

Notwithstanding the difficulties that its interpretation presents, the problem is real and can be formally posed for its elucidation, as follows: What is the *nexus* that links the Viryas who intervene in the Secret History of the Thulegesellschaft? Is it an esoteric Secret Doctrine, the knowledge of which converts the Viryas into *members* of a Secret Society, such as occurs in the organizations of the Synarchy?

A first answer can be found in our previous dissertation, when we compared the Thulegesellschaft with the Secret Societies of the Synarchy and spoke of the *closed circles*. Taking that teaching into account, it can be considered that the Viryas

(Trithemius, Agrippa, Theophrastus, John Dee, etc.) were forming a *closed circle*, the *charismatic center* of which was a Divine Hyperborean. This answer is correct but insufficient because, for example, it does not provide *indications* for overcoming the previously cited paradox: the Viryas are “esoterics” but, as we were affirming, *there is no* “common esotericism” that serves as a nexus between them. But as only the rationalistic observation of performing a “comparative analysis” is responsible for this apparent paradox, we will expand this answer by drawing on some concepts of the Hyperborean Wisdom. To begin, let us consider that from the fact that “all Viryas are esoterics,” the rationalist mentality attempts to extract an inflexible law: the “common esotericism.” And the truth is that “the fact that all Viryas are esoterics” *does not imply that this must be the nexus that unites them*; but to accept this conclusion without reflection may lead us to seek *another explanation for the fact of the nexus*, which would be another error, since the most correct attitude is not to seek *any explanation*.

For only the *Catena Aurea* can be distinguished as a bonding factor between the Viryas, but it is *absolutely transcendent* and cannot be represented: *it can only be intuited*. Outside of this, it is useless to attempt to establish similarities. There is no common philosophy or Secret Doctrine; nor do they belong to a Secret Society; nor do they know that others often seek the same thing as them, much less *how many there are*. However, they all synchronistically coincide in the *Eternal Return* and that is why they find themselves in certain historical circumstances.

There is a common Hyperborean meaning in the events that the Viryas of our history protagonize, but this meaning, this intention, this tendency to mutation, *is not a logical category but a strategic one*. It cannot be apprehended with reason because it is not rational; but neither is it irrational. Here, there is another paradox, which is *just and necessary*. We will now see why.

A Strategy is a *means*, or the planning of the means, in order to obtain an *aim*. In war, the Strategy is the total set of measures that must be taken to obtain success, i.e., “to impose our will on the enemy.” For the Hyperborean Viryas, it is *clear and patent* that there is a cosmic war and that we are all involved in it. The *blood confusion* that the lost Viryas suffer is also an *ac-*

tion of war, a satanic tactical action, to prevent the awakening, the return to the Origin, and the liberation from the Great Deception. That is why we say that *all actions of the Hyperborean Viryas are of a strategic category* and that, as long as one does not possess a clear vision of the Strategies at play, it is not possible to *interpret* such actions.

When a people are collectively identified with a philosophy or religion, going to the extreme of regulating daily life according to norms, precepts, or laws emanated from such a philosophy or religion, we say that they constitute a “way of life” for those who practice it. Thus, we say “Buddhism is a way of life,” or “they govern their life by the Decalogue of Moses,” or “the Neoplatonists were living in accordance with the Stoic philosophy,” etc. In an analogous way, it can be considered that *Strategy is the way of life of the Hyperborean Virya.*

And if, when we see a mendicant monk of India meditating for long hours and fulfilling all of the Buddhist rites, we say “he lives every minute of his life according to his religion and it is always present in him”; we must also, analogously, say “the Hyperborean Virya lives every minute of his life according to the Hyperborean Strategy and it is always present in him, indicating to him the path of return.”

To make these affirmations clearer, let us briefly consider the hypothetical steps that a lost Virya would follow to find the path of return. It will thus become evident that such steps are nothing other than *tactical movements*, i.e., strategic categories.

II.

Initially, the Virya is *lost*. The Satanic Strategy, the principal tactic of which is based on *confusion*, on creating confusion, or increasing the existing one, contributes to perpetuate that state.

The following rule must be kept in mind here: *for the Synarchy, “culture” is a strategic weapon.*

The Virya seeks to orient himself and for this purpose he puts himself on *alert*. This is the first strategic category incorporated into ordinary life.

The permanent state of *alertness* will eventually lead him to doubt reality, its sensible appearance, and to distrust reason and the rational, which will reveal themselves as accomplices of the Great Deception. Under these conditions, it is possible

to *awaken*, to convert oneself into an *awakened Virya*, by the experience of a *nostalgia* for *another world*.

That primordial world that is intuited, that attracts with the force of the return, is the Fatherland of the Spirit and *its memory is contained in the blood*. It had been *forgotten* and that forgetfulness occasioned the loss of orientation, confusion, and transformed him into a *lost Virya*. But when experiencing the Minne, the Blood Memory, other eyes that never sleep will be opened, different from the physical eyes that only see the illusion, and a *permanent state of alertness* will be assumed, necessary in order not to cede to the enemy strategy and fall into a new and greater confusion.

If this occurred, the Virya is already a *strategic subject* of whom it can be said: “all his movements aim at a single end”; “nothing can deviate him from his path,” “his valor and intrepidity know no limits”; in short, “he is an *awakened Virya*.”

The awakened Virya will relentlessly go into combat against the *elementarwesen* without *evaluating the probable outcome of his struggle*, i.e., *without projecting himself in time*. Only the action itself will interest him, to the extent that it contributes to exalt his heroic or mystical virtue to such a degree that any return to ordinary life, to the Great Deception, becomes unbearable. That human limit that can only be reached when the mind has been stripped of every dogma, of every moral, of every material desire, of every bond with the world, that primordial summit to which can only be climbed in the heat of combat, that spiritual height inaccessible to anyone who possesses a hint of evolutive materiality, of duality, or of opposition to duality, that point of *no return* to which these sentences and many others allude is, with all precision, the product of the *Pure Blood*.

But when one speaks of *blood impurity*, this concept should never be confused with that of *racial impurity*, in the meaning of race mixing, miscegenation, or bastardization. It is true that ethnic miscegenation causes a *genetic confusion* and that this increases the *strategic confusion* of the Virya, but it is only a part of the problem and, we would say, the least. *Blood impurity* is an esoteric concept of the Hyperborean wisdom that refers to the *gnostic content* of the blood and, of course, to *another blood*, different from the mere lymphatic plasma or hemoglobin. We must bear in mind, then, that *racial purity* is a favorable factor but that this by itself ensures nothing with re-

gard to blood purity. And it is of no use, for example a racially pure people like the *Celts*, if they are totally dominated by the Synarchic Strategy.

That is why when the awakened Virya decides to go into combat in order to *purify his blood*, this attitude, by itself, makes him independent of his degree of ethnic and genetic miscegenation.

Different is the case of the collective mutation, where the racial factor is important because a *community of blood* can be *charismatically* guided by a leader or Führer. This case is dealt with at length in our work, *Treatise on the ⚡ Psychosocial Strategy*.

The awakened Viryas are charismatically bonded to each other, due to their common origin, by a synchronistic tie that we call *Catena Aurea* or *Golden Chain*. It is a non-physical bond, inapprehensible to reason, so we will momentarily desist from explaining it, although we will return to speak of it later. For now we will only say that the awakened Virya, the one who has *sensed* the Minne and traces the *Catena Aurea* toward the Origin, *incipiently* possesses a condition that *places him beyond* any racial qualification or social pigeonholing. We do not say that this condition makes him *superior*, but that it *places him outside* of any standard of measurement. This condition is called *Hyperborean lineage* and refers to a concept of *Race of the Spirit* totally unknown to the common people because of the fierce concealment to which it has been subjected. (To speak of a “Race of the Spirit” is to touch upon one of the most terrible Mysteries, which is that which refers to the arrival of the Hyperborean Siddhas to the Solar System and the cosmic *treason* perpetrated by a part of them. We will return to this history.)

We were saying that the condition of possessing Hyperborean lineage, the awakened Viryas possess it, *incipiently*. What do we mean by incipient Hyperborean lineage? Let us first look at a *vulgar* interpretation of the phrase “incipient lineage,” before responding according to the Hyperborean Wisdom:

The word “lineage” refers to the familial ancestry, i.e., the blood ties, and these are possessed or not, without a choice. On the other hand, “incipient” means “to begin,” so that if we say “Pedro, of the Perez family, has an ‘incipient lineage,’” we mean “Pedro *begins* to have lineage of the Perézes,” which can

only refer to some *characteristic* of the Perézes that distinguishes them and that clearly *stands out* in the members of the stirp, i.e., a *familial hereditary profile* that *begins* to manifest itself in Pedro or that Pedro incipiently represents.

Therefore, to speak of the *lineage* of a person does not consist in alluding to the mere fact of belonging to this or that family, but implies a whole universe of races, qualities, and styles that tend to form a well-defined familial *type*. In this respect, *Jacques de Mahieu* writes: "In homogeneous lineages, the existence of such a *type* cannot be doubted. The common language itself admits it when it uses the expression 'family resemblance.' History shows us lineages of craftsmen, farmers, industrialists, artists, statesmen, warlords, etc., *lineage is thus a differentiated hereditary biopsychic whole.*"

It is puerile to emphasize these concepts that until a few centuries ago were unanimously known, but which the universal Bolshevization, beginning with the French Revolution, has suppressed from "Western culture." (For the Synarchy, "culture" is a strategic weapon). However, it is still possible to observe that in those non-massified domains of human activity, i.e., where it is essential to count on some *artisanal* ability, the laws of lineage continue imposing themselves. "In the human order," says Jacques de Mahieu, "it is well known, although questioned by the deniers of the inheritance of acquired characteristics, that several generations are necessary to form a good worker in certain difficult trades, glassmaking for example. We have more confidence, in this respect, in the testimony and, above all, in the practice of industrialists who affirm the reality of the phenomenon, than in the assertions of scientific theoreticians. Besides, were not those transformists of the last century contradicting themselves who, while denying the inheritance of habits, were founding their theory of the evolution of the species on a gradual modification of the generations under the effect of the environment, a modification that could only be brought about by the hereditary transmission of the progress made?"

We now know that a lineage can be incipient *in an individual* if it weakly represents the characteristics of the familial *type*. It is a concept that includes the idea of *development* or *evolution*: there is a *type* and a path, the biological differentiation toward the *type*. That is to say a *being* and a *becoming*. That is why the *realization of the familial tendency* is the best adaptation of a

member to the figure of the “type” or the metaphysical “Arche-type” that supports it and of which (the type) is its visible expression.

Let us now respond to the question about the incipient Hyperborean lineage that an awakened Virya possesses by using concepts from the Hyperborean Wisdom. The Hyperborean lineage does not recognize types. However, analogous to the case of the familial lineage, there is a *tendency* in the Virya that impulses him toward a *realization*. This *tendency* emerges from the Pure Blood, from the Minne, and the *realization* toward which it points is obtained by an inverse path, marching backward, seeking the Hyperborean origin of the Spirit. There is not here, as in the case of Pedro Pérez, a becoming of something determinate, the conformation of a type; on the contrary, in the inverse way, the *dissolution of every type* occurs, culminating the process in a sudden *ontological indetermination*. Marching along the inverse path of return, one *finally* accesses an uncreated state that can only be qualified as *pure possibility*. It is the *realization of the Hyperborean tendency* (Minne) of the Pure Blood that is called Spirit or Vril.

This *realization* implies the definitive *mutation* of the awakened Virya into an immortal Siddha and his *liberation* from the material order that rules creation. The Spirit or Vril is *indescribable* and it is prudent to refer to it as *pure possibility*. However, the only concept of *existence* that the Hyperborean Wisdom possesses corresponds to the Vril. That is to say that nothing spiritual has existence outside of the Vril and that all intermediate psychic states must be regarded as illusory. Nothing exists outside of the Vril because to obtain the Vril is *to be outside of everything*. And “everything” is the universe of The One, of the matter-ordering Demiurge whose existence pervades everything and whose will *supports* the things of the concrete world.

For these reasons, for the Hyperborean Wisdom, the *Paśu* does not exist because its *soul* is a projection of the hypostatic monad that the Demiurge *thought* and *emanated*. Evolution only offers an illusory development of the conscious subject that can never surpass its own Archetype or the ultimate monad. The soul of the Paśu may appear as “very evolved” and even “Great,” or “very holy,” but it is pure illusion; its “existence” is subject to the Great Cosmic Cycles and has a fatal dissolution in the *pralaya* or *mahapralaya*. When culminating

one of these Great Cycles of evolutive manifestation of matter or a *manvantara*, the *phagocytation* of all that is “created” by the Great Deceiver is produced and signifies the end of all Masters, Gurus, Chohans, Rishis, etc.

Every Virya must always keep in mind the following strategic rule: “*there is no possible alternative of existence outside of the Vrils conquest.*” That is to say, there is no other alternative to exist, apart from the mutation.

III.

On the other hand, there is what we call “Hyperborean Wisdom,” that is, the Wisdom of the Siddhas, present in all epochs of humanity. What a colossal error it would be to pretend that it constitutes a *rational* system of knowledge! And yet this is the most common attitude. Rationalism always attempts to find simple relationships; for this purpose, it compares and seeks coincidences, analogies, similarities. If it finds them, it establishes laws; which must be, as far as possible, infallible. If it does not find them: then something like an abyss separates the instances. This attitude, suicidal from the intellectual point of view, can be summed up in two words: either reason or nihilism.

Even the most subtle Spirits cede to the goddess of reason. Let us briefly review some of the ideas, as brilliant as they are fatuous, put forward by the rationalists in their stubborn attempt *to unify* the principles that sustain the different sciences:

Those who study religions and *compare* them, usually discover that something like a Primordial Tradition has left a common trace in the different myths (Something that, on the other hand, has always been affirmed by the most enlightened Spirits of humanity, identifying this Primordial Tradition with the Hyperborean Wisdom.) As soon as they have considered this, they *arbitrarily* conclude that this Primordial Tradition refers to a *single common myth*. Nothing is more rationalistic and absurd as this hypothesis, which, naturally, they never succeed in demonstrating, in spite of the interesting symbolic analogies that they usually make use of in their theories.

This mental attitude is naïve and childish but, by dint of generalization, it is today “natural” or “scientific.” Let us look at other examples.

If one speaks of ethnology or anthropology, one seeks a single race that, starting from a “center of diffusion,” be it the East

or the West, Palestine or the Gobi, etc., justifies *all* known migrations with its movements. If one speaks of religion, a *single myth*, situated in a “center of diffusion,” be it Atlantis, or Lemuria, or Mu, or Hyperborea, or America, or Asia, or “the North,” or “the pole,” etc., one must justify *all* religious cosmogonies and even “esotericism,” which would be a quintessential part of the mythical synthesis.

The same occurs if we speak of the origin of the Universe, where a *single, central* explosion is responsible for *everything* that exists; or if we refer to Physics, where a *unified field* law, which enables us to deduce *all* of the laws of electromagnetism and gravitation, is still waiting for someone to invent it.

These *reasonings*, these *unifying* ideas, *because they are logical*, are naïve and childish, as we have already said. But, attention: here “childish” should be read “proper to the Paśu,” for the rationalism that we are describing, *is the way of thinking of the Paśu*. And the tendency to unify is also proper to the children of Jehovah Satan; let us not forget that the culmination of this tendency is the conception, also absurd and childish, of *monotheism*, a concept that conceals the pretension of *unifying*, in the figure of “The One” Demiurge, *all* religious devotions. Because the tendency to unify and monotheism are also *war tactics* of the Synarchic Strategy.

Even Max Müller, whose love for Jehovah is evident throughout his work, has remarked on the abuse that has been made of this “tendency to unification.” In his lecture “Henotheism, Polytheism, Monotheism, and Atheism,” he writes the following:

“If you consider how natural, how intelligible, how inevitable, was the origin and growth of the principal deities of the Veda, you will perhaps agree with me that the whole controversy, whether the human race began with monotheism or polytheism, hardly deserves a serious discussion, at least so far as the Indians, or even the Indo-Europeans, are concerned. I doubt whether this question would ever have arisen, unless it had been handed down to us as a legacy of another theory, very prevalent during the middle ages, that religion began with a primeval revelation, which primeval revelation, could not be conceived at all, except as a revelation of a true and perfect religion, and therefore as monotheism. That primeval monotheism was supposed to have been preserved by the Jews only, while all other nations left it and fell into polytheism and

idolatry, from which, at a later time, they worked their way back again into the purer light of a religious or philosophical monotheism.

“The science of language,” Max Müller continues, “offers in this respect many points of similarity with the science of religion. Without any warrant either from the Bible or from any other source, nay, without being able to connect any clear understanding with such a theory, many mediaeval, and even modern, writers have maintained that language too owed its origin to a primeval revelation. The next step was, that this primeval language could only have been Hebrew; the next step again, that all other languages must be derived from Hebrew. It is extraordinary to see the learning and ingenuity expended in voluminous works to prove that Greek and Latin, French and English, were all derived from Hebrew. When, however, no amount of torture could force from Hebrew the confession that she was the mother of all those degenerate children, the very failure of these repeated efforts showed that it was necessary to commence a new trial by an impartial collection of all the evidence that could be brought to bear on the origin and growth of human speech. This, which we call the historical study of language, soon led to a genealogical classification of the principal languages of the world, in which Hebrew received at last its right place, by the side of other Semitic dialects; while the question of the origin of language assumed an altogether new form.”

In the previous articles (I and II) we have denounced that a widespread attempt to justify the *charismatic nexus* that bonds the Viryas consists in imagining the existence of a presumed “common esotericism” or “Secret Doctrine.” In this article III, we have seen how rationalism elaborates theories on the basis of the *unity* of the principles that fundament the sciences. And now we must consider that, because of this “tendency to unify,” when it is discovered that the Viryas are “esoterics” and that said esotericism is related to a “Hyperborean Wisdom” of which they all speak, the rationalists cannot resist the temptation to suppose, gratuitously, that such a “Hyperborean Wisdom” constitutes the sought-after “common esotericism” or “Secret Doctrine.” If this is so, one reasons, said Hyperborean Wisdom must be a “system of knowledge” or at least a “common myth” that, rationalized, gives rise to an “Esoteric Doc-

trine.” This is a *logical* conclusion and that is why *it cannot be true*.

We, on the contrary, affirm that the Hyperborean Wisdom is *unique for each Virya* in particular and, therefore, its teaching is different in all cases, there being nothing *in common* among the Viryas. However, in spite of the absolute individuality that the knowledge acquired by each Virya presents, certain *temporal coincidences* usually occur, which lead to a synchronous contact between the Viryas, when they have adopted a path that passes through collective mutation. The service in favor of the Race causes the synchronic coincidence between the Viryas, who protagonize stories like that which we are narrating, and in which it would be useless to attempt to discover a physical or cultural *nexus* outside of the *common origin*, which, as we already said, is absolutely indeterminate.

In synthesis, the Hyperborean Wisdom, different for all, *cannot be taught*, but *it can be learned*. This conclusion is *not logical but absurd* and that is why *it must be true*.

Let us make a final summary. We have posed the problem of the lack of evidence of an actual *nexus* or *link* between the Viryas of our History and of the impossibility of considering the Hyperborean Wisdom as a rational *system* of knowledge. The rationalist analysis will say that without such *links* and without such a *system*, nothing can exist. We have in our favor the irrefutable fact that the story *can be told* and that the Hyperborean Wisdom can *be learned*.

But it is necessary to go deeper into this problem, and that is why, in article IV, we will approach it from another point of view.

IV.

This reiteration that we make, going back several times over the same problem, may undoubtedly surprise the rationalist mentality accustomed to linearly transit or “vertically advance” in the conviction of finding, at the end of the road, a *single* solution, a definitive and immutable answer. But we do not share this *logical* optimism. We believe that there are many answers to the same question, and that even the simplest answer can acquire unsuspected profundities if it is *re-thought*, *repeating* the reflection, i.e., the mental path that gave rise to it. That is why we have to pose and respond, many times, to the same questions, so that, through all the *different* answers that

arise, the concepts of the Hyperborean Wisdom that govern our thoughts can be glimpsed. So let us go around the circle again and reformulate the initial question.

To possess Hyperborean lineage, as we have already said, signifies, among other things, to be something unique; not repeated or to be repeated, which constitutes a true *spiritual individuality* (*Nous*), *transcendent*, opposed therefore to the illusory *psychic individuality*, *immanent*, of the Paśu. Hence, to *discover* the Blood Memory, to access the Minne, to consciously enter into the mystery of one's own Hyperborean origin, always implies living a new adventure, never thought or imagined by anyone. The Hyperborean Wisdom is *mutant* and unfailingly *changes* anyone who receives its gnosis. But this *change*, this *mutation*, is *unique*. So original is it, that it is why the destiny of the awakened Virya is called *uncreated*, as opposed to the "destiny" of the Paśu, which is absolute *mechanical determination*.

In light of these considerations, we can once again respond to the fundamental question that we formulated in article I. It is the question that arises in all rational minds when they attempt to find a connecting "esoteric" link between different representatives of the Hyperborean Tradition: Can one, by the rational means of association or comparison, establish a *connection* that links the "*Great Spirits*" of History? Can one find a *nexus* between their ideologies and doctrines? Can one find a relationship that *organically* reaches and *links* the sacred symbols that express their different myths?

Let us first see how the very rational minds that usually formulate this question respond to it.

In the perplexity and bewilderment that follow the discovery that *it is not possible to find an esoteric system* that justifies the existence of so many men who *lived according to such a system*, the answer comes, to these *beaux esprits*, by logical deduction: if it is not possible to *rationally apprehend* the so-called Hyperborean Wisdom, which flourishes here and there, this must be attributed to two causes: either such a Hyperborean Wisdom *does not exist*, or it is called so to psychic manifestations of an *irrational* character. In the first case, if it does not exist, then its representatives are frauds, vulgar pretenders. In the second case, if it is an irrational knowledge, our civilization calls those who possess it as *madmen*, since only *reason* differentiates man from animals and guarantees his *normality*. For a

world tailor-made for the Paśu, the given answer will then be clear and categorical: either frauds or lunatics. There is no possible alternative and the theosophical-evolutionist system of the Synarchy and its infinite sects, shows the limit, miserable indeed, to which they allow themselves to go in their “spiritual” or “esoteric” inquiries. Outside of “theosophism,” one is either a fraudulent pretender, swindler, crook, etc., or insane, schizophrenic, hysterical, psychotic, etc., but, in any case, firmly repressed by the satanic hosts.

The difficulties that the previous questions present to the rational mind, and that appear any time that a *serious* study of the Hyperborean Wisdom is attempted, for the most part come from the refusal to accept that one is facing a *paradoxical* fact. Rationalist pride finds it difficult to accept that reality poses paradoxes, and even less is it prepared in order to confront them. And yet, therein lies the key to rational defeat. It is not that “if there is no connection, nexus, relationship, link, etc.,” between different “facts protagonized by Viryas who claim to be inspired by the Hyperborean Wisdom,” the conclusion is: either such a “Wisdom” does not exist or it is a mere irrational knowledge; and then: frauds or madmen. The fallacy lies in opposing the “rational” with the “irrational” to the exclusion of the posed paradoxes because, precisely, the Virya’s Hyperborean condition converts him into a “maker of paradoxes.”

We will clarify this when we study the Hyperborean Cosmogony of the Thulegesellschaft; but for now let us keep in mind that, by virtue of a *twofold opposition* to the world of the Demiurge, every “Hyperborean,” Siddha or awakened Virya, *generates paradoxes* in whatever action that he undertakes or thinks with respect to said world.

The Swiss psychiatrist C. G. Jung has made an interesting reflection that is now worth remembering as a complement to our preceding critique of “esoteric rationalism”:

“Has it not yet been observed that all religious statements contain logical contradictions and assertions that are impossible in principle, that this is in fact the very essence of religious assertion? As witness to this we have Tertullian’s avowal: ‘And the Son of God is dead, which is worthy of belief because it is absurd. And when buried He rose again, which is certain because it is impossible.’ If Christianity demands faith in such contradictions it does not seem to me that it can very well

condemn those who assert a few paradoxes more. Oddly enough the paradox is one of our most valuable spiritual possessions, while uniformity of meaning is a sign of weakness. Hence a religion becomes inwardly impoverished when it loses or waters down its paradoxes; but their multiplication enriches because only the paradox comes anywhere near to comprehending the fulness of life. Non-ambiguity and non-contradiction are one-sided and thus unsuited to express the incomprehensible.

“Not everyone possesses,” Jung continues writing, “the spiritual strength of a Tertullian. It is evident not only that he had the strength to sustain paradoxes but that they actually afforded him the highest degree of religious certainty. The inordinate number of spiritual weaklings makes paradoxes dangerous. So long as the paradox remains unexamined and is taken for granted as a customary part of life, it is harmless enough. But when it occurs to an insufficiently cultivated mind (always, as we know, the most sure of itself) to make the paradoxical nature of some tenet of faith the object of its lucubrations as earnest as they are impotent, it is not long before such a one will break out into iconoclastic and scornful laughter, pointing to the manifest absurdity of the mystery. Things have gone rapidly downhill since the Age of Enlightenment, for, once this petty reasoning mind, which cannot endure any paradoxes, is awakened, no sermon on earth can keep it down. A new task then arises: to lift this still undeveloped mind step by step to a higher level and to increase the number of persons who have at least some inkling of the scope of paradoxical truth.”¹¹

Thus far is the position of the “esoteric rationalists” with respect to the posed question and our critique. We will now give a simple answer, elaborated on the basis of the synthesis of the concepts addressed in this chapter:

“Each quest on the path of Hyperborean Wisdom is completely ‘different.’ There is no ‘common esotericism’ but infinite individual esotericisms, proper to each Virya. Therefore, there is no ‘link,’ ‘nexus,’ ‘relationship,’ etc. between the Hyperborean Viryas that can be quantified.”

With this paradoxical answer, the chapter should conclude. However, we will briefly extend to highlight another wide-

11. “Introduction to the Religious and the Psychological Problems of Alchemy,” *Collected Works*, Vol. 12, C. G. Jung; p. 15.

spread error that is caused by not distinguishing that a *community of language* does not imply a *community of ideas*, but a *community of concepts*.

This is a “cultural” semantic error, because rational analyses are carried out on the basis of *concepts* enclosed in linguistic constructs: *words* that attempt to represent *ideas* in order to make communication between men possible; “*common*” *ideas* that, naïvely, we believe have the same meaning for all.

Let us take a word; for example: “God.” Everyone “knows” what it means, they “know” the *concept*, as far as goes reason. But “God” the *idea*, an *idea* that goes beyond reason, is it the same for all the possessors of such a word? Or, said in another way, does the word “God” evoke the same *idea* in everyone? Of course not. And substituting the word “God” for any other, we immediately realize that all words, outside of their conceptual content, that is, their conventional definition, exceed the rational, possess an ideal content proper to each person, non-transferable and inexpressible, which, most likely, keeps some relation with what is called *character, style, etc.*, of the individual and that intellectually differentiates him from others.

When this elementary distinction between the thing “in itself,” the *idea* of the thing, and the *linguistic concept* that the “name” of the thing represents is not taken into account, it is possible to commit tremendous analytical errors. But if this error is added to the usual rationalist obsession of applying dialectical analysis to everything that exists, then the result can verge on the borders of foolishness. Borders are effectively reached in the case of “esoteric rationalism” because, the Viryas, being the possessors of a completely personal Hyperborean Wisdom, and having already committed an error by pretending to find a “common esotericism,” a second error is committed by not realizing that the “esoteric” or “symbolic concepts” that the Viryas use refer to *absolutely* different ideas. As in the case of the “mysterious coincidences” between the Viryas, which may lead one to believe in a “destiny” or other form of determination, here is a phenomenon of *synchrony*. For in all that is subject to the *temporal order*, i.e., to the Will of the Demiurge, the “law of evolution” and the Plan of The One acts; but to the extent in which the Virya purifies his blood, a *spiritual desynchronization* with said *order* occurs (of which we shall speak at length). This *desynchronization* with the Satanic Plan generates, in the framework of a Hyperborean Mystique,

the *synchrony* between the Viryas and the Siddhas. And said *synchrony* is, for who attains the Mystery of the Pure Blood, present in *all concrete acts, including linguistic communication*.

Hence, the famous “esoteric concepts” and “universal sacred symbols” that “esoteric rationalists” wield as *proof* or *evidence* of a *Secret Doctrine* or “common esotericism,” do not have and will never have the same significance for the different Viryas. And if any of them, upon contact, use them in their linguistic communications, this coincidence of words and concepts must be understood simply as a phenomenon of *synchrony*. That is why the awakened Viryas, even speaking the same language and using the same words, never coincide in the ideal content of the concepts, since they possess an *absolutely differentiated* consciousness that can only coincide in one thing: the common center; or in the figure of the Führer, who, from the common center, establishes the “charismatic bond” among the Viryas.

A very widespread error has been evidenced: the non-distinction between a “linguistic concept” and a “mental representation” or the “idea” of the thing. However, this error can acquire very subtle variants, not so easy to notice, in certain “esoteric rationalists” who, even accepting the highlighted distinction, perhaps by adhering to some “idealistic philosophy,” intend to subject *ideas* to the “*forceps*” of the *Archetypes*. But this “mold,” this “ultimate limit” that supports the qualities of the thing, the Archetype, is an *ontological* attribute rather than a *formal* one, and the objection raised is thus inscribed within the field of *metaphysics*; although it causes horror to consider that there are those who profess a sort of “metaphysical rationalism.” Let us study, lastly, this variant of the error:

The “esoteric-metaphysical-rationalists” object that there is an ultimate stage, a higher, archetypal plane, to which all ideas refer. The Archetypes, pure symbols emanated by the Demiurge, enclose the ontological essence of all that exists and are those that determine the *form* of things as a whole. The *ideas* “thought” by man are, then, mere copies of His *universal Archetypes*. And since the idea of the same thing, thought by many persons, nevertheless shares a common Archetype, there would be no gnoseological possibility of surpassing said Archetype. In other words, “God,” the Archetype-creating Demiurge, ought to be at ease: man (Paśu) cannot give any “surprises”; he has not eaten from the Tree of Gnosis.

We will explain it in another way. If one thinks of an idea represented by two words, “equilateral triangle,” he will evoke in his imagination a typical “figure”; if ten think of an “equilateral triangle,” each one of them will represent to himself a typical figure in this or that manner; the same if a hundred, a thousand, a million, or *all men* do so, as long as they think of an “equilateral triangle,” they will evoke a figure or thing that, although in each one of them, in each individual consciousness, is different, *can never surpass the common Archetype* of all the equilateral triangles that have been or will be, thought or to be thought, from the beginning of the world until its, without a doubt, near end. It is now understood that man (Paśu) will not give “surprises”: no matter how he thinks of a *universal idea*, he will never think of it originally.

This perspective, which subjugates the rationalists, presented here as a metaphysical objection, is *completely false* for the Hyperborean Viryas, and in no way invalidates the answer given by us to the fundamental question about the nexus between the Viryas. *But it is true for the Paśu*. They cannot think any idea originally because their consciousness (soul) is *absolutely determined* by the Archetypes. The awakened Virya, on the other hand, possesses a *Hyperborean Spirit*, totally alien to the world of the Demiurge and its determination; a Spirit that is *pure possibility* and is also called *Vril*. The Hyperborean Wisdom is “thought” with this uncreated organ and that is why one Virya will never *coincide* with another, neither on the *path* nor on the *way back*, nor in anything that can be “universal” or “common.” There is, as we will later see in the **⚡** Psychosocial Strategy, *only one idea common* to all Viryas, and it is not archetypal. This idea is a Blood Memory that is summarized in the word *Origin*.

This single element common to all Viryas, the Primordial Origin, is what constitutes the *fact of the Race*; and that is why the Hyperborean Wisdom calls the Origin: the Race of the Spirit. It is by virtue of the Origin that *every action* of the Virya is *always* directed toward the Race, toward the good of the Race, seeking its mutation.

The Hyperborean Wisdom says: “Every action in favor of the Race brings us closer to the Origin and to our own mutation, but every search for the Origin, which is performed independently of the Race, must *refrain from action* in order to be effective; it must be limited to the Minne.”

The attitude of John Dee, Rudolf II, and all the Viryas who intervene in the *Secret History of the Thulegesellschaft* must be interpreted on the basis of the articles that make up this chapter, on the basis of their teaching. Perhaps to the rationalist criterion it is pure madness that several respectable persons fight, risk their assets and their lives for things “of no practical value.” And the most incomprehensible thing: without any of them attributing the same value or the same properties to those things, acting on the basis of the intimate certainty of their usefulness; without knowing each other and even without knowing, at times, against whom they were fighting.

Madness, pure madness, the rationalist would say; without seeing that all of them are behind that primordial fact that is the *Origin* and that is why they synchronistically coincide in the Eternal Return, because the *Origin* makes them participate in the Hyperborean Race and “charismatically bonds” them.

John Dee Seventeen Years Later



r. *John Dee* studied Trithemius' *Steganographia* for 17 years. At first he did so in secret, for he soon realized that that strange alliance of Dominicans, Jesuits, and Jews to destroy Cornelius Agrippa was constituting a warning that should not be disregarded. However, he did not associate Agrippa's fate with the conspiracy that ostracized Trithemius. In the sixteenth century it was extremely difficult to perceive the organized power of the Synarchy and, above all, John Dee was English. He was fearing and abhorring the inquisitorial persecutions of the Church, but: "that was occurring on the continent." In England, there were neither Dominicans nor Jews; the Jews "were given to commerce" or to their usual occupation: "usury"; and that "absurd" comment that the Jew *Laquedem* made to him about the Filí, was not even taken into account. This foolish "security," a psychological attitude that everyone in England under Elizabeth I was sharing and which, in a certain sense, is necessary for the inhabitants of a country that is intended to elevate itself to the rank of "Empire," was in this case detrimental to John Dee.

The sage's investigations, after reading *Steganographia*, were centered on the "language of the birds"; that is, the original Hyperborean language. As he was progressing in his studies and awakening to the realities of the Spirit, his philological capacity was being "charismatically" amplified. He was possessing a true "gift of languages" and after so many years of investigation, he succeeded in synthesizing the "language of the birds" that he called *Enochian*. But let us go by parts. When speaking of an original language, a primordial language, or Hyperborean language, let us not fall into the childish pretension that such a language is the only source from which all the languages of humanity are derived. We have already previously warned against this rationalist error, which we qualify as a "synarchic tactic." Let us now note that, consequently, the myth of a single original language is well detailed in the Hebrew Bible, in which the story of the Tower of Babel is transcribed.

The curious story of a tower constructed by the first men, who were upholding the declared objective of "reaching heav-

en,” has not ceased to occupy the minds of its readers, ever since the Bible was translated by the Seventy, between 285 and 246 AD, according to the order given by Ptolemy II. But it was not so much this objective, “reaching heaven,” as the punishment imposed by Jehovah Satan, “the confusion of tongues,” which was astonishing to the reader of the Bible. Why the *confusion*?

In the eighteenth century, for example, Voltaire, equally surprised, satirically wrote:

“I do not know why it is said in Genesis that Babel means confusion; for *Ba* means father in the eastern languages, and *Bel* means God; Babel means the city of God, the holy city. The ancients gave this name to all their capitals. But it is incontestable that Babel means confusion, either because the architects were confused after having raised their work to eighty-one thousand Jewish feet, or because the languages were confused; and it is evident, since that time, that the Germans no longer understand Chinese; for it is clear, according to the scholar Bochart, that Chinese is originally the same language as High German.”¹²

It is a joke that Voltaire finds the German language similar to Chinese, but, irony aside, the same questions that thinkers have posed for centuries underlie the quoted paragraph. We, basing ourselves on the Hyperborean Wisdom, will give an explanation of this ancient myth while drawing from it important *strategic* conclusions. But let us first recall the biblical text:

“Now the whole earth used the same language and the same words. It came about as they journeyed east, that they found a plain in the land of Shinar and settled there. They said to one another, ‘Come, let us make bricks and burn *them* thoroughly.’ And they used brick for stone, and they used tar for mortar. They said, ‘Come, let us build for ourselves a city, and a tower whose top *will reach* into heaven, and let us make for ourselves a name, otherwise we will be scattered abroad over the face of the whole earth.’ Jehovah came down to see the city and the tower which the sons of men had built. Jehovah said, ‘Behold, they are one people, and they all have the same language. And this is what they began to do, and now nothing which they purpose to do will be impossible for them. Come, let Us go down and there confuse their language, so that they will not

12. *Dictionnaire philosophique*, Tome deuxième, Voltaire, entry for *Babel*.

understand one another's speech.' So Jehovah scattered them abroad from there over the face of the whole earth; and they stopped building the city. Therefore its name was called Babel, because there Jehovah confused the language of the whole earth; and from there Jehovah scattered them abroad over the face of the whole earth" [*Genesis II:1-9*].

Let us now analyze how this text should be interpreted using the guidelines of the Hyperborean Wisdom:

1) "Men were possessing one language," means: the Viryas were possessing one Pure Blood and that is why they were understanding each other. "Men intend to reach heaven" means: the Viryas intend to flee from the chains of Jehovah Satan.

2-4) "For this purpose they construct a tower," means: the Viryas utilize a Hyperborean technique.

5-7) "Jehovah Satan notices the maneuver and decides to prevent it by confusing their tongues so that they do not understand each other," means: Jehovah Satan provokes the strategic (blood) confusion from which the "charismatic bond" between the Viryas is eclipsed.

8-9) "After the confusion of tongues, Jehovah Satan scatters the men over the face of the whole earth," means: after the blood confusion, the Viryas are lost.

It should not be surprising that by symbolically interpreting this "myth," the classic tactics of Jehovah Satan are exposed, for it is the transcription, adapted by the Hebrews, of several ancient stories that actually occurred during this endless war. When fleeing from Egypt, Moses stole numerous papyri with stories of Atlantis; and on the basis of this material, adapting and falsifying everything, he elaborated the Torah. Therefore, in the biblical text, very ancient stories are confused with the famous tower of Babylon, which, in turn, is often also confused with the Ziggurat of Borsippa: Birs Nimrod.

Going back to our interpretation of the biblical account of the Tower of Babel, we can now comprehend, symbolically, that "to rediscover the original language," that *which all are capable of understanding*, signifies *annulling the tactics of Jehovah Satan*, i.e., it is equivalent to purifying the blood of the Viryas, to transmuting the race "backward," toward that common origin in which there was no *confusion* and all could orient themselves "in the direction of Heaven."

With respect to the traditional expression “language of the birds,” it is worth clarifying that it should be interpreted symbolically as a language that allows one to communicate with the Hyperborean Siddhas. René Guénon says in this respect, referring to another Germanic myth this time, that:

“We see heroes who defeat the dragon, like Siegfried in the Norse legend, immediately understand the language of birds; and this allows us to easily interpret the symbolism in question. Indeed, the victory over the dragon has as an immediate consequence, the conquest of immortality, represented by some object, the approach of which the dragon was defending; and this conquest of immortality essentially implies the reintegration into the center of the human state, i.e., into the point where communication with the higher states of being is established. It is this communication that is represented by the understanding of the language of birds; and, in fact, birds are frequently taken as symbols of angels.”

The language of the birds is then the “language of the angels.” However, the word “bird” also has a less profound analogy than its relation to “angel,” but equally significant.

“The ‘auspices,’” writes René Guénon “(from *aves spicere*, ‘to observe the birds’), omens drawn from the flight and the song of the birds, are more especially to be brought closer to the ‘language of the birds,’ understood then in the most material sense, but still identified with the ‘language of the Gods,’ since these were considered as manifesting their will through these omens and the birds thus played a role of ‘messengers’ similar to that which is generally attributed to the angels (hence their very name, since this is precisely the proper meaning of the Greek word *angelos*), although taken under a largely inferior aspect.”¹³

A *Hyperborean language* must be similar to the birds, to their flight, to their singing, something unpredictable but nevertheless understandable to all. The important thing in the communal fact is that *all the members understand each other* with the greatest possible precision, and this condition is in no way satisfied *exclusively* with an oral and written language, such as occurs in our societies. A race that had sufficiently developed telepathy, to give just one example, would not use words or grammatical constructions for communicating, but symbols

13. *Symboles de la science sacrée*, René Guénon, 1962

that allow “bringing” the “receiving” minds “closer” to the essence of the idea thought by the “transmitting” mind. The symbols need not be conventional, such as our letters and signs that are learned by all in school, but could be *inherited archetypically*. Taking this example to the extreme and considering phenomena of *synchro*ny, a race could be conceived, such a one that none of its members shares with another its symbols, for each one would inherit *archetypal tendencies* along the lines of the “behavior patterns” of biology, and the symbols would only be formed after the mental act performs an *archetypal metamorphosis* destined for the telepathic *emission* of the idea. This would be a race in which each individual would possess *a language of his own*, personal, and yet all would understand each other. Analogously, the Hyperborean Viryas can, thanks to the “language of the birds,” receive a *message prior* to the collective transmutation, which prepares or *initiates* them for the quantum leap; and that is why every leader who intends to utilize the Hyperborean Mystique must possess the keys of the Psychosocial Strategy that imply the mastery of the forgotten language.

The language that John Dee extracted from *Steganographia* was called by him *Enochian* due to Trithemius’ affirmation that by means of it *Enoch* had “spoken with the angels,” as recorded in the *Book of Enoch*. This Enoch was a Hyperborean Virya; but his story, very ancient, was also falsified by the rabbis, although not as much as Genesis, which is why it was declared apocryphal, i.e., “occult,” shortly after Christianity was imposed. But as the history of Enoch is part of a larger plot, let us leave its commentary for another occasion.

John Dee developed the Enochian language during the 17 years that he had *Steganographia* in his possession; but he did not manage to establish “contact” with the angels during that period. This situation was producing uneasiness in the English scholar because, given that Trithemius was expressly assuring that “the mastery of the Enochian language provokes, by that very fact, an immediate relationship with the angels,” John Dee was finding no other explanation for their silence than to attribute it to a fault or error in his deciphering of *Steganographia*.

Plunged into perplexity, he thought of resorting to the same system that Trithemius tried through Cornelius Agrippa: he decided to seek help by sending encrypted messages in a book.

This book was called *Monas Hieroglyphica* and it was on cryptographic methods! But disguised in its text were several messages to the Hyperborean Viryas. It should be added that no one responded in John Dee's lifetime, to so strange a way of asking for help.¹⁴

The solution to John Dee's problem, which was none other than a total absence of clairvoyant aptitudes, came by way of Queen Elizabeth I who, as we already saw, gave him Princess Papan's mirror. For from the very instant in which this occurred, John Dee's expectations began to be fulfilled with facts so convincing that soon all his yearnings were satisfied. But let us not get ahead of ourselves. Upon taking the mysterious stone mirror in his hands for the first time, he was irresistibly attracted by its *profound brilliance*. This sensation was so intense that it took him a considerable effort to look away from it, while his body was moved, in both directions, by powerful energies from heaven and earth.

However, he would receive the greatest surprise in his study, when the Unknown Superiors, the Divine Hyperboreans, the immortal Siddhas made themselves present before his astonished Spirit. We already said that the Aztec talking stone was an Atlantean transducer. The following should be kept in mind: said lithic instruments *detect Pure Blood*. Thanks to a now unknown Atlantean technology, in front of which our solid-state electronics would pale with envy, it is possible to *calibrate* these transducers so that *they resonate* with a determinate human physiological constitution. The interaction between the resonant stone and the energy fields of the human body, produces a "valve effect" by opening a "path" to planes other than the "physical plane." This is not the best way to exercise spiritual transcendence and in fact, in Atlantis, this system was only being utilized for ordinary communications, as it *only operates in the material universe of the Demiurge*. But during this stage of the Kaly Yuga, our racial guide, Khristos Lúcifér, is at levels of physical "quantification," as the Black Sun of the Earth, thus making it possible to establish a type of "instrumented contact" with the Hyperborean Siddhas who await, together with Him, the awakening of the Viryas.

14. The original Latin contains the code, with its use of unusual capitalizations, wordplay, and markings, not able to be preserved in English translations.

This is how Princess Papan's stone mirror "worked" with Dr. John Dee's lymphatic-circulatory system and put him in communication with the Siddhas. In a few weeks, the good sage had obtained an enormous quantity of instructions in the Enochian language. It was the Strategy that the Siddhas were proposing to the man of the sixteenth century and in which was basically: 1^o) a method for the formation of a rigorously luciferic human elite; 2^o) a planning on the basis of the Hyperborean Wisdom so that such supermen (the mentioned elite) can control the crowds and bring them to the point of a collective mutation.

The knowledge revealed to John Dee was offering marvelous prospects for revolutionizing humankind, but it was, of course, extremely dangerous to handle if one was not acting with prudence. And this virtue was in short supply in our hero. So, pressed by Elizabeth I to advance the results of his investigations, John Dee eventually revealed to the sovereign that he had entered into a "dialogue with the angels."

In any case, this confession was taken with skepticism by the Queen and other scholars and courtiers, who were soon also in on the "secret," since the mirror was only functioning when it was manipulated by John Dee. And that incredulity would have been a good thing for him, were it not for the imprudent publicity given to the affair that attracted some undesirable onlookers: the Welsh Druids, who since the death of Mary "the Catholic" were swarming about the court of Elizabeth I and, at the time, were preparing the intrigue that would bring Mary Stuart to the scaffold. All of a sudden John Dee had unwittingly converted himself into the Synarchy's most dangerous enemy; and the consequence, a powerful conspiracy was to be unleashed against him. However, John Dee's "dangerousness" was not arising from the fact of being in possession of the magic mirror; or even from possessing the writings in the Enochian language. Such facts were very negative for the Synarchy and they were surely justifying, by themselves, a rebuttal against the sage. But what was really *taking the demons' breath away* was a project that he elevated to Elizabeth I and that, curiously enough, is still preserved in the Royal Archives of England. We refer to "Project Thule," conceived by John Dee between 1581 and 1587, in which he was proposing the occupation of Greenland by English troops in order to, thanks to the use of certain strange properties that "space" was

possessing there, “extend” the kingdom to other worlds, conquering them by means of struggle, if necessary.

This fantastic plan, the details of which can be verified in the documents that still exist in Great Britain, was inspired by the legendary history of Nimrod, the Kassite king of ancient Assyria. Thanks to the use of the magic mirror and the knowledge obtained by means of *Steganographia*, John Dee elaborated said plan, which was perfectly feasible to be applied, but which we will not be able to correctly comprehend without first possessing the keys to Nimrod’s feat. They are those that we will try to reveal in the following chapter.

The Legend of Nimrod "the Defeated"



he content of Project Thule caused a tremendous impact on the satanic hosts. It is worthwhile for us to make a stop in our story in order to find out the reason for this reaction, investigating its remote causes. To do so, we will momentarily leave *John Dee* and go back in time four thousand years. We will go to Assyria, to the ancient city of *Borsippa*, and contemplate the tower of Nimrod. It will be a pleasant walk, tinged with teachings of the Hyperborean Wisdom that until today had been kept in the strictest secrecy. And thanks to these millenary concepts, when resuming the history of Dr. John Dee, his Thule project will be clearly understood by us.

In the second millennium BC, an invasion brought the *Kassite* Hyperboreans to Assyria. They were natives of the Caucasus and were carrying a Stone of Venus next to the banner of the leontocephalus eagle. The eagle with a head of a lion and spread wings, was trapping two rams between its talons that were the symbol of the God Enlil, Jehovah Satan, worshiped in Mesopotamia by all the tribes, among them the *Hamite* or *Habiru* shepherds who would go with Abraham to Palestine and Egypt. This same banner would be carried later, thousands of years later, by other "barbarian" peoples, also natives of the Caucasus, this time of Germanic Race, but the rams would no longer be found between the talons of the eagle but the lamb, the symbol of that God of the shepherds who was attempting to usurp the millenary Hyperborean figure of Khristos LúCIFER.

The Kassites were coming following the dictates of their Archer God *Kus* who had made a pact with his Initiates so that said people participate in the Essential War. In the City of Borsippa, to the north of Nineveh, King Nimrod, utilizing the numerical technique of the Ziggurat, constructed an enormous Tower over a vortex of telluric energy. Here is what was being intended: "to attack the Abode of the Immortal Demons," that is to say, Chang Shambhala. This purpose, which today may seem to be the product of an unbridled fantasy, is nonetheless perfectly possible and the proof of it is in the success obtained by Nimrod when his *Elite warrior archers* targeted and shot

down several of the “Immortal Demons.” [We are narrating elements of the Hyperborean Wisdom in all this, so that if the truth is not intuited through the Minne, it is difficult to understand what we are talking about.]

In Antiquity, when the influence of the Kaly Yuga was not so significant and the memories of the Hyperborean Wisdom and of the war against the Demiurge were still preserved in some Atlantean remnants, the task of founding peoples and cities was requiring the assistance of especially gifted Initiates. The same for the raising of idols or sacred effigies, the *utility* of which, which was not mere worship, has today been forgotten. The most important element that was being taken into account for such foundations was the *location of telluric energy currents*. In the **second** place, were the astrological coordinates to which, nevertheless, the blindness of men tends to grant preeminence in some epochs. Justly, the power or survival of any city depends on the correct geographical situation on which it is erected and if, for example, cities like Rome or Jerusalem have lasted millennia it is because they are seated upon great centers of force. Thousands of years ago, those in charge of precisioning the emplacement of a city were called *Cainites*, Priest sacrificers who knew the Magic of the Spilt Blood. These sacred murderers, who were dowzers,⁷³ that is to say, “sensitive” to the forces of the Earth, after detecting a convenient vortex were effectuating the human sacrifice destined to “polarize” the telluric energy and obtain a phenomenon of “resonance” with the Blood of the Race, in a way that the place converts into a “friend” to its inhabitants and an “enemy” of future invaders. Of such ritual murders for purposes of foundation, we remember for example Romulus, who to ensure the inviolability of the walls of Rome had to execute his twin Remus, etc.

Let us make a brief parenthesis to consult the Hyperborean Wisdom about some guidelines that it is necessary to take into account, in order to correctly interpret the action of war undertaken by King Nimrod.

It can be considered with all propriety that the *potency* of a people to liberate themselves from the satanic yoke of the Synarchy directly depends on the esoteric-Hyperborean conditions of their Initiates. If there are awakened men, sufficient-

73. Soothsayer; who uses the dowser or divining rod to search for water, ore, etc.

ly capable of locating the currents and vortices of telluric energy, and they do not despise the combat that this “positioning” inevitably brings with it, then the Race is on its way to mutation, it has converted into a Hyperborean “closed circle.” For reasons of blood purity, the peoples called “barbarians” are always those who are closest to these Hyperborean praxes; but these same peoples, to the extent that they are civilized, or synarchized, lose *potency* and, then, their *possibility of mutation* is weakened. The *Hyperborean racial purity* of a people is evaluated in the *capacity of its Viryas* to *awaken* the Blood Memory. The *Hyperborean racial potency* of a people is their *capacity of opposition* to the illusory reality of the material world. It means taking an active part in the Essential War and, therefore, supposes some Hyperborean strategic conception. Potency is then evaluated by the clarity of the strategic aims and objectives that men are capable of formulating and by the effective steps that are taken in that sense. The result of the action is never qualified by any material guideline; furthermore: the action is never qualified at all. For the Hyperborean Wisdom what matters is the Strategy (that is: the clarity of goals and objectives and the way of obtaining them, in other words, the *potency*.) In every case, the action qualifies itself, independently of the “results.” The “success” or “failure” of an action has no meaning in the Hyperborean Strategy because such words refer to concepts elaborated from an incorrect perception of the world, from Maya, the Illusion. An ancient Hyperborean sentence can illustrate this, which says: “for the Wise Warriors, every war lost on Earth is a war won in other Heavens.”

The struggle for principles, such as “honor” or “friendship,” which is tradition in the knighthood, stems from a celestial or angelic chivalry that is distinctly Hyperborean. The celestial chivalry of the Hyperborean Siddhas is the prototype that the Virya must follow in order to participate in the cosmic war, for the *other modes* of this conflict would not be comprehensible to him in the present state of the Kaly Yuga.

Let us see, briefly, some aspects of this prototype of the Hyperborean hero in its “knight-errant” figure: He who a “knight-errant” engages is a *spiritual combat* because the result of the dispute is not decided by the weapon skill or mere physical strength, but by the degree of justice that accompanies each combatant. Faith in such a transcendent principle is what ren-

ders contingent all previous efforts and skills put into the struggle. For the knight, it is infallible that he who has the truth must triumph... in this or another heaven. Therefore, it is not so much the adversary or the weapons used, not even the military training, but the *manner in which the combat is spiritually proposed*, that is to say: the strategy adopted. History and Tradition abound in examples of “novice” squires, or young lads, in different degrees of logical ineptitude for the fight, who nevertheless, against all odds, were victorious, counting on truth, justice, liberty, etc., in their favor.

Even if such heroes *fall* on the battlefield, who will deny that the valor put into taking action does not mean a triumph, even if one does not clearly know *where* such a victory *is won*? Finally, let us say that this knight-errant prototype can only be perceived because it is already in their Blood Memory, in their Minne. However, the Synarchy attempts *to confuse* the Virya knight by *collectivizing* this marvelous *individual* posture by means of satanic organizations formed for such an aim, from Chang Shambhala, or by introducing essential deviations in others that could have a Hyperborean principle, such as some medieval orders of sad end.

Returning to the Hyperborean concept of *racial potency*, I can say that, in general, a *potent people* are those who, having identified the Enemy, go to war within the framework of a “Hyperborean Strategy.” And, in particular, that a *people of great potency* are able to *cross the threshold* and move the theater of operations to the plane of the Immortals.

Many ways to *cross the threshold* exist. The *lost Viryas* or simple Pašus, the “Initiates” in synarchic Satanism, for example, do it during their “Ritual Death,” abjectly dragging themselves before the sinister “Guardians of the Threshold,” at times misnamed “Dwellers,” “Watchers,” or “Egregores.” After demonstrating their “evolution” by means of oaths, pacts, and alliances, they receive the “illumination,” that is to say, they lose all contact with the Origin and suffer the definitive enchainment to the Universal Plan of the Demiurge Jehovah Satan. Then they can cross the Threshold and “participate” in a thousand different ceremonies or covens, according to the sect or religion that has “initiated” them, and that have the surprising characteristic of solely occurring in the consciousness of the adept, since it is a miserable illusion. The “Immortals” of Chang Shambhala will never involve anyone in their meetings

except to destroy him, however, many are the imbeciles who believe they know the sanctum sanctorum of the White Brotherhood and its “Planetary Instructor,” the King of the World.

But there is another way of “crossing the Threshold,” which does not require humiliations or promises and that does not imply the total blood confusion of the Virya as in the case of synarchic initiation. It consists in proudly standing up, with weapons in hand, before the Guardians of the Threshold... and destroying them.

It will then be said, “but where is the Threshold? Is it not an ‘initiatic’ symbol?” It is not. The Synarchic Strategy is based on *confusing*, that is, making obscure what should be clear. And a widely utilized tactic is to give an unreal, symbolic meaning to that which one desires to hide and, on the other hand, to exalt as real and concrete that which one desires to “reveal.” Thus, a reality such as the existence of “induced” or “dimensional gates” is considered a fantasy by sensible people and, for example, utopias like communism, socialism, the UN, or the World Government, are fanatically taken as real possibilities.

The Threshold, that is, the entrance toward the plane on which the Immortal Demons dwell, can be *established and opened* if one possesses an appropriate technique. The Hyperborean Wisdom teaches to open “induced gates,” for their use in offensive tactics, in seven different ways. One is utilizing lithic technology. Another is mandalic. A third harnesses telluric energies. A fourth is phonetic, etc. But all are based on the *distortion of space*, on the intersection of planes.

Once the Gate is opened, by any system, one should proceed with energy and decision to cause the greatest possible number of casualties to the Enemy. This possibility may produce surprise but the truth is that the “Immortal Demons” of Chang Shambhala *can die*. These “Immortals,” “Masters of Wisdom,” Gurus, Golen, Elders of Zion, Men in Black, etc., are irremediably linked to the Demiurge. They are immortal for the duration of material “Creation,” that is to say, as long as the Demiurge maintains *His will placed in manifestation*. Their existence is the fate of the Paśu: a pure illusion. That is why *Gurdjieff*, in his Fontainebleau *ashram*, in France, was responding to the Paśus who were wondering “if immortality could be obtained with his method,” which “he was guaranteeing within the limits of the solar system,” an absolutely correct answer, but which was misinterpreted by the Paśus as a joke by the

Russian Siddha. But later on we will attempt to give a more complete idea about this “white” plane, Chang Shambhala. For now we should keep in mind that together with the “Immortal Demons,” coexist, in a higher hierarchy, the Two Hundred Hyperboreans coming from Venus who caused the collective mutation on Earth and enchained the Eternal Spirits in the animal-men, or Paśu, that the Demiurge had created. The Two Hundred Hyperboreans are Atlantis’ Siddhas of the Dark Side and Lemuria’s Lords of the Flame. They are truly Immortal but as they have taken physical bodies in order to copulate with the human Race, fulfilling their absurd roles of Manu, they can be violently disincarnated, an action that, apart from disrupting their plans, has the virtue of destroying the *genetic matrix* of the presumed *root Races*.

One can, then, *kill the Immortals*, who are only so if violence is not exerted against them, for they inhabit a fold of space in which time *passes in a different mode*, in such a way that their bodies are physiologically maintained stable at a “determinate age.” With this terrible affirmation, I will close here the doctrinal parenthesis that I opened earlier. One is now, by virtue of the above, in conditions to interpret the feat of the Hyperborean King Nimrod. For example, one can now qualify the Kassites as a *great racial potency* for having taken, according to the aforementioned definition, the theater of operations to the Lair of the Immortal Demons. Let us continue, then, with the story.

We will repeat what was said at the beginning. The Kassites had made a pact with their Archer God Kus to participate in the Essential Conflict. They were fearsome warriors, perfectly capable of dealing with beasts, men, or Demons.

For years, they pilgrimaged until the Cainite Initiates decided that the most powerful “Serpent of Fire,” that is: the vortex of telluric energy, was found within the limits of the city of Borsippa, which was already existing and inhabited by a tribe of Habiru shepherds. It did not represent any difficulty for a determined people to wage combat against infernal Demons. In a brief time, the Kassites were dominating the Plaza and their Cainite Initiates were performing the necessary Rituals to “calm” the Serpent of Fire.

Immediately afterward, they put into practice an adequate Strategy for the imminent offensive. From it, we should highlight two tasks that demonstrate the capacity of the Cainite

Initiates. The first one consisted in training an Elite capable of resisting the powerful magic that the “Demons” would use when “the Gate of Hell” was opened. This Hyperborean Elite, distant ancestor of the **H**, would have the sacred mission of exterminating the Demons, a mind-boggling task in which they would surely lose their lives or their minds.

The other task was perhaps the simplest to execute but that which would require the greatest dexterity in the handling of the Hyperborean Wisdom: to construct the “Magic Tower” that, thanks to the harmony of its exact dimensions, its form and its functionality, channels the telluric energy, *dispersing it* around the “Eye of the Spiral” of energy. In the architecture of Temples, the most important thing, from the point of view of “ritual functionality,” is the base plan, its symbol. The most utilized are: the circular, cross-shaped, or octagonal base, although they have also been constructed with a rectangular, pentagonal, hexagonal base, etc. But in the Hyperborean architecture of war, buildings similar to fortresses, the base plan of which is almost always a “labyrinth,” are usually constructed. Such a figure should be utilized due to the technical exigencies of the canalization of telluric energies and I may add that the application of the “technique of the labyrinths” is another of the seven ways to open induced gates. Of course, we will not cease repeating that the products of these Hyperborean techniques are not automatic, that is to say, they include the participation of trained men in their functionality.

The war plan of Nimrod was then comprised of three steps: 1º) open the gate to the plane of Chang Shambhala; 2º) access the famous Threshold of synarchic initiation; 3º) attack, attack, attack...

To complement this colossal Strategy, a series of logistical details were being counted on, like for example the choice of weapons or the possibility of using the very ancient “magic cuirasses” of Atlantis. With respect to the weapons, the Cainite Initiates decided that the warriors would use arrows constructed according to an ancient formula: the feathers would be of ibis; the shafts, of Caucasian acacia; and the points, of stone, would be small, perfectly conical stalactites collected from some deep and mysterious caverns that a shaman tradition affirms are connected with the Hyperborean Kingdom of Agartha.

As for the “magic cuirasses,” it is easy to imagine today, in light of modern electronic technology, what a “matter-precipitating electrostatic field” enveloping the whole body would be like. However, this “electronic cuirass,” called **magic** in the Age of Nimrod, was a common defense in the days of Atlantis, up to about twelve thousand years ago. The Cainite Priests only managed to endow King Nimrod and his General Ninurta with such a protective field for a few hours, since no one else in the people had the conditions of purity necessary to apply the very ancient technique. Only two warriors, when Atlantis had entire armies that were using the “coat of metal”! This technique suffered a slow degradation until completely disappearing due to blood confusion. In the beginning, when the Gods came to Earth millions of years ago, they covered their physical body with a “cuirass of fire.” Then in distant Lemuria, the Initiates, Kings and warriors, were materializing minerals, so they used to be called “Men of Stone.” And, finally, in the middle of the Atlantean Kaly Yuga, the Siddhas of the Dark Side were materializing metal cuirasses around their bodies that were protecting them from sword or spear strikes in the manner of our medieval coats of mail. The Atlantean cuirass of materialized metal is, furthermore, the origin of the Jewish legend whereby Nimrod was possessing the “vestures” that Adam and Eve wore in Paradise. He would have obtained them from Ham, one of the sons of Noah, and later on, after fighting with Esau, another great hunter, he would have lost them. These legends are found in the Talmudic Midrash Sepher HaYashar (twelfth century) and Pirkei de-Rabbi Eliezer (90–130 AD) and also in the Babylonian Talmud (500 AD), etc.

The Guardians of the Threshold also depend on cuirasses and powerful weapons, among them, for example, the “*Om ray*,” an Atlantean weapon with which the sweet “Masters of Wisdom” of Chang Shambhala usually disintegrate the disciples who show themselves unruly.

Armed like this, he looks like a terrible enemy, but that is pure appearance, only material power. The warriors of Nimrod would carry the Hyperborean Sign of *Hk*, the Rune of Fire that no “Immortal Demon” can face. And much less the Two Hundred Traitorous Hyperboreans. That Sign represents for Them *the truth*, the inevitable memory of the abandoned Divine Origin. And, like the Gorgon, it is not possible for them to look at it without undergoing grave risk.

When the Tower was ready, a metallic column of iron, copper, silver, and gold, crowned with a gigantic Emerald, was placed on the turret at the top. Said stone had been delivered to the Kassites by the God Kus when he involved them in the fight with the Demiurge Enlil (Jehovah Satan), whose Abode was in Babylon. And as the Initiates were telling between whispers, the Sacred Stone had been brought from Venus by the Gods who were accompanying Kus when they arrived on Earth, before man existed. During the many decades that the voyage of the “barbarians” lasted, from the slopes of Mount Elbrus, in the Caucasus, the possession of this “Present from Heaven” was the stimulus that enabled to face all types of hardships. It was the *Center* around which the Race was *being formed*; it was the *Oracle* that was making possible to hear the Voice of God and it was the *Tabula Regia* where the Names of the Kings could be read. It was also the *Primordial Sign* before which the Demons would recoil in terror and against which no infernal potency had power. Through its intermediary, *the Gate of Hell would be opened in Heaven* and the truceless combat could be engaged against the servants of who enchained the Eternal Spirit to Matter. Many peoples have been called “barbarians” by other more “civilized” peoples, alluding to their “savagery” and “unconsciousness.” But one needs to be a “barbarian” to make a pact with the Gods and take part in the Essential War. Only the *guarantee* of blood purity of a few “barbarians,” intrepid and immune to satanic traps, can decide the Gods to place the *cornerstone* of a Sacred Race in the world. In other words, the “traps,” the temptations of Matter, are set everywhere and that is why it is necessary to be “barbaric” or “fanatical,” but also naïve, “like a child,” or like Parsifal, the pure madman from the Arthurian legend.

After the construction of the Ziggurat, messengers were sent to the remaining Kassite cities and villages, since their Kingdom was including Nineveh and other minor cities, as well as numerous northern encampments that were going as far as Lake Van and were even reaching the slopes of Ararat. Thousands of Ambassadors were arriving at Borsippa to appreciate the Tower of Nimrod and to pay homage to *Ishtar* the Goddess of Venus and to Kus, their racial God, husband of Ishtar. A small number of their Hittite cousins also arrived from the south, from Babylon to which they had just conquered, with

whom the Kassites set out together many decades before, from the Caucasus.

Everything was prepared for the summer solstice, the day on which Chang Shambhala is “closest” to our physical plane. On that day, the people of Borsippa were gathered next to the great Ziggurat and a contrast of emotions was visible on all faces. The Kassite invaders, hunters and farmers, that is to say, Cainites, were openly demonstrating their savage joy for culminating an undertaking that had absorbed several generations. And in that furious joy the longing for the coming combat was throbbing. An ancient Aryan proverb says: “the fury of the warrior is sacred when his cause is just.” But if that thirst for justice leads him to confront an Enemy a thousand times superior, then a miracle must *necessarily* occur, a mutation of human nature that takes him beyond material limits, outside of Karma and Eternal Return. Leonidas in Thermopylae is no longer human. He will be a Hero, a Titan, a God, but never a common man. That is why Nimrod’s people, in their holy fury, were sensing the coming collective mutation; they were feeling themselves elevated and were seeing the deceitful reality of the Demiurge Enlil dissolve. They were seething with valor and like this were drastically purifying their blood. And that Pure Blood, boiling with fury and valor, when rushing to the temples (of the head) brings along the Memory of the Origin and makes the primogenial images parade before the interior sight. *It subtracts*, in a word, from the miserable reality of the world and *transports* the true spiritual essence of man. In these magical circumstances, it is not strange that a whole people gain the immortality of Valhalla.

Contrasting with this warlike euphoria was a terrible anguish being noticed on the faces of numerous citizens. They were those who were constituting the primitive Habiru population of Borsippa, shepherds and merchants, who were always worshiping the Demiurge Enlil.

According to their traditions, Jehovah Satan had preferred the shepherd Abel and despised the agriculturist Cain, which is coherent since “shepherd is the office of the Paśu,” son of Jehovah, as the Hyperborean Wisdom teaches. For these reasons, they were experiencing a profound hatred against King Nimrod and the Cainite Initiates. A hatred such as only cowards can feel, those who, similar in every way to the rams and sheep that they graze, call themselves “shepherds.” That ha-

ted for the warrior is that which hypocritically disguised, exalts the “virtues” of sentimentalism, charity, fraternity, equality, and other falsehoods that are well known for the suffering in this *civilization of shepherds* in which the Judeo-Christianity of the Synarchy has plunged us. And that hatred, which I am considering, arises and is nourished from a source called *fear*.

Fear and Valor: here are two opposites. We have already seen the transmuting power of valor, the expression of which is the Fury of the Warrior. Fear, on the other hand, expresses itself through pusillanimous and refined hatred, which after multiple distillations yields envy, rancor, slander, and all kinds of insidious sentiments. Fear is then a venom for the purity of blood as valor is an antidote. The exaltation of valor elevates and transmutes; it dissolves reality. The exacerbation of fear, in contrast, sinks into matter and multiplies the enchainment to illusory forms. That is why the Habiru shepherds of Borsippa were murmuring prayers between their teeth to Enlil while, as hypnotized from terror, they were contemplating the Cainite ceremony.

Early in the morning, when Shamash, the Sun, had just risen, the drums and flutes were already electrifying the air with their monotone and ululant rhythm. On the various terraces of the Tower, the Initiates were unbridledly dancing while ceaselessly repeating “Kus, Kus,” invoking the God of their Race. The Priests, fifty in number, were officiating the rites prior to the battle, installed around the enormous labyrinthine mandala constructed on the floor of the upper turret with mosaics of lapis lazuli, an exact replica of the labyrinth at the base of the Ziggurat. Throughout the enclosure was predominating the color blue, emphasizing the great green Emerald consecrated to the Spirit of Venus, the Goddess that the Semites were calling Ishtar and the Sumerians Inanna or Ninhursag, with an intense and twinkling brilliance.

While the Priests were staying under the ceiling of the upper turret, outside, in the lateral passageways, King Nimrod and his two hundred archers were preparing themselves to die.

The bellic climax was “*in crescendo*” as the hours were passing. Around midday, an ectoplasmic, ash color vapor was able to be observed that was seeping through the columns of the upper turret and was languidly revolving around it, enveloping the imperturbable warriors in its capricious volutes. Within

the turret, the vapor was covering the totality of the enclosure but was not going above the waist of the tallest of the Priests.

The crowd that was remaining petrified observing the top of the enormous Tower suddenly witnessed, astonished, a phenomenon of corporealization of the vapor. At first, only a few noticed it, but now it was visible to all: the cloud was adopting definite forms that were remaining a moment to dissolve and return to once again corporealize. The principal "motif" of the mysterious reliefs of the vapor were fundamentally constituting figures of "Angels." Angels or Gods, but also Goddesses and children. And animals: horses, lions, eagles, dogs, etc. And chariots of war. It was a whole Celestial Army, that which was materializing in the vaporous cloud and rotating slowly around the turret. And as the chariots of combat were passing by, pulled by lively winged steeds, the Warrior Angels were clearly encouraging Nimrod. So were the women, but it is convenient that we pause on Them an instant because the mere contemplation of their Hyperborean beauty is enough to illuminate the heart of the most passive man and tear him out from the clutches of the Deception. Oh, the Hyperborean women! So beautiful! They were wearing a short skirt girded at the waist by a thin cord from which was hanging, at their side, the scabbard of a graceful and fearsome sword. The bow crossed over the chest and, on the back, the full quiver. The braids of gold and silver of a hair that was seeming as soft and light as the wind. And the Faces. Who would be capable of describing those forgotten Faces, after millennia of deception and decadence; Faces that, nevertheless, are engraved with fire in the Soul of the warrior, almost always without knowing it himself? Who would dare to speak of those sparkling eyes of cold courage that irresistibly incite the fight for the Spirit, to return to the Origin, eyes of steel, the gaze of which will temper the Spirit until the instant before combat but that, after the fight, miraculously, will be like a balsam of frozen Love that will cure every wound, that will soothe every pain, that will eternally resurrect the Hero, the one who tenaciously maintains himself on the Path of Return to the Origin? And who, lastly, would dare to even mention their primordial smiles before which all human gestures pale; before whose singing sounds, the music and rumors of Earth are extinguished; transmuting laughter that could never resonate among the misery and deception of material reality and that, therefore,

can only be heard by him who also knows how to listen to the Voice of the Pure Blood? It is impossible to attempt to sketch the purest image of those Hyperborean women, eternal companions of the Men of Stone, whose projection in the ectoplasmic vapor was being produced thanks to the powerful will of the Cainite Initiates. I will only add that said images were enormous. While the other figures were rotating at a certain distance from the Kassite warriors, They were detaching themselves to embrace and caress them, and then their size was able to be appreciated. They were doubling in height to King Nimrod, the tallest warrior of Borsippa.

The people were clearly seeing these effusions and, although it was evident that the Goddesses were speaking to the warriors in an imperative tone, while pointing toward the sky, no one, from among them, could have heard if those phantasms were really emitting any sound, since the frenetic rhythm of the flutes, drums, timpanis, and harps was deafening. But perhaps the Hyperborean women were directly speaking to the Spirit, perhaps their voices were to be heard inside of each warrior as they say that the Augurs sense...

Enveloped in that frenzy, but momentarily stunned with astonishment by the alterations of the white cloud, the citizens of Borsippa did not notice when one of the Priestesses abandoned her dance. She went running up the remaining floors to arrive at the turret, but before entering the vapor it took the form of a multitude of winged children who fluttered around her, pouring etheric liquids over her head from no less etheric amphorae. However, such supernatural manifestations did not stop her. Anointed from head to toe by the graceful cherubs, she resolutely advanced and entered the turret. The fifty Priests, upon noticing her irruption, ceased all chanting, all invocation, and turning toward her, were staring at her. Finally, the Priestess stopped her light step ahead of the entrance to the labyrinth and, without a word, pulled a cord and dropped her tunic, leaving her completely naked... except for the jewels. These were exceedingly strange: four *serpentine* bracelets of gold, which she was wearing coiled, one on each ankle and one on each wrist, a necklace similar to the bracelets, a tiara studded with milky and opaque stones, two earrings and two serpentine rings and a red stone in her navel.

Of the whole, what was most impressing, because of the exquisite design and the ability of the goldsmiths, were the bracelets. Each one was showing three coils; those of the left leg and arm, with the tail of the serpent outward and the flat head toward the interior of the body; the coiled bracelets on the right leg and arm were showing the serpent as "coming out" of the body; on the necklace, the serpent was pointing with its tail toward the earth and the head, this time strangely bicephalous, was just under her chin. All the serpents had small green stones encrusted in their eyes, and its body wrought and enameled in bright colors. Upon seeing these marvelous pieces of goldsmithing, no one would have suspected that they were in reality delicate instruments for channeling telluric energies. The young woman is breathtakingly beautiful. One can observe her as she walks sure-footedly through the labyrinth, which she seems to know very well because the floor is almost indistinguishable, under the dense cloud of ectoplasmic vapor. If she came to take the wrong path, if she hit a wall, it would be taken as a bad augury and the operation would have to be suspended until the following year. But the Priestess does not vacillate, she has the Thousand Eyes of Blood open and sees down there, at the base of the Tower, how the telluric energy, as an irresistible serpent of fire, also runs through the resonant labyrinth. And all were trusting in Her, in the terrible mission she has undertaken, which begins there but is prolonged in other worlds. They were trusting because she is a magician Priestess, born fifth in a family of dowzers, with blood so blue that the veins are drawn like dense trees under the transparent skin. They all think of her while she goes through the labyrinth singing the hymn of Kus.

The Priests hold their breath while the svelte legs of the Priestess dexterously traverse the last stretches of the mosaic-labyrinth: she is about to arrive at the "exit." She has triumphed!

But that triumph signifies death, as will be shortly seen. Right at the end of the labyrinth is the column of stone and metal where the Hyperborean Emerald shines with rare brilliance. The Priestess stops in front of it and, elevating her eyes to the heavens, ascends the three steps that lead to the base of the column, which is of low stature as the Emerald barely arrives at the level of her pubis. A curious thing: the Emerald has been cut in the form of a vagina, with a central slit, which is

possible to see because it is found on the upper facet, that which faces the roof of the temple. On the contrary, to the Priestess, despite being naked, it is not possible to observe her sex because a fold of flesh covers her lower abdomen, absolutely hairless. This physical characteristic, which today only the Bushmen women preserve, is the most evident proof of their Atlantean-Hyperborean lineage. The Cro-Magnon women were possessing a “natural skirt of skin” and the ancient Egyptians of the first dynasties also, as can be verified in numerous bas-reliefs.

The Priestess has traversed the labyrinth, has “guided” the serpent up to the upper temple and has led it through the column of stone and metal. Now its fiery head begins to press under the Hyperborean Emerald, magically igniting it and bathing the enormous enclosure and all its occupants in green light. Outside, the rumbling of drums and flutes has acquired a rhythm so rapid and such an intensity that it is impossible to think or do anything else other than contemplate the Ziggurat, the turret at the top surrounded by Nimrod and his archers. They, in the meantime, observe the interior scene through the columns, invisible to the people gathered at the base of the Ziggurat.

It is already midday, the precise moment in which Shamash is overhead. The grave voice of one of the fifty Priests addresses the beautiful Priestess, speaking in short phrases, pronounced with the cadence of a ritual prayer:

O Princess Isa:

The fate of the Race is in your hands.

We have traveled many lands

and crossed through countless countries,

to arrive here,

seeking to launch the Final Battle.

Years of roads and hardships

since we abandoned the sacred mountains

where we were twice-born

and on the summit of which Kus was gathering us

and speaking to us of Primordial Times.

We knew in those distant days

that we are not from here.

And, after remembering our Divine Origin,

how could we remain there,

deceived by El, the “Elder” Enlil?

Yes, everything was debased before our eyes.
The fields suddenly withered.
The flowers turned their perfume horrible,
and the heat of Shamash no longer seemed good to us.
All of a sudden we saw the stunted ears of cereal
and even the mountains lost their imposing height.
All of that occurred when we looked at the world,
after the Wise Kus
spoke to us of the forgotten Heaven,
filling our chests with nostalgia.
It was then when we decided
to undertake the Path of Return to the Origin.
And charge dearly for the treason of the Demons
who had deceived us with their magic.
Many of us were those who set out
from the sacred mountain,
toward different directions.
And many are the kings
who since then seek
the path of Heaven
with their Hyperborean peoples.
But Kus had warned us
that some would not soon arrive
if they were deceived again
by the astute Demons.
But he accurately directed us
because we have no other aim
than to conquer Heaven.
The invincible Nimrod guides us,
to whom El fears
because the former's Blood is as Pure blue
as the sea
and as red as the dawn of Shamash.
We are a valorous people like the lion
and we fly high like the eagle,
but our eye is acute
and our talons tear the Enemy to shreds.
We are a harsh people
who know no pardon
and grant no truce in the fight.
Nimrod leads us,
an archer like no other on Earth.

The stars drew him
 hunting in the sky.
 We carry with us
 the Green Stone of Kus
 so that *we never* get lost *again*.
 What more could we ask for?
 Get away, infernal Demons!
 For here are *an awakened people*
 to whom you will not be able to frighten
 or ever deceive.
 En garde, accursed Demons!
 Because an indomitable Race has risen up
 and will combat you to the death.
 Today the road has come to its end.
 The great Kash sea
 and the Kashshu land
 have been left behind;
 our women and children,
 our elders and best warriors,
 remain buried in trodden paths.
 Many have fallen for the glory of Kus
 and for following the heroic Nimrod,
the chief who will lead us to victory
in this or in other heavens.
 In Borsippa we have camped.
 To construct the highest Tower in the world
 and tame the Serpent of Fire.
 There is no other like our Ziggurat,
 neither in Babylon nor in Assur,
 nor in distant Egypt,
 nor in the land of the Aryans.
 Since the Flood covered the Earth
 and punished the Demons
 who were inhabiting the islands of Ruta and Daitya,
 no other Tower like it has been seen.
 The Gods rejoice for us
 and the Demons fear us.
 How hard we have worked to construct it!
 O Isa, this effort must not be in vain.

The Priestess was at the same site, standing in front of the Emerald of Kus, keeping respectful silence while her eyes, beautifully almond-shaped, were staring at the Priest. He continued with his monologue:

We have come here to die fighting
and you, sweet Princess
have chosen to die first
to open the Gate of Heaven for us.
We will punish the Demons
and avenge your death, divine Isa,
daughter of the Serpent of Venus!

The beautiful Cainite Priestess visibly turned pale; however, her eyes fiercely shone while these valiant words were coming out of her mouth:

The Constructor of Worlds of Illusion,
the infamous Enlil,
has sunk into an eternal dream,
while his fecundated body
is born and reborn in every existent thing.
He has allied himself with the Demons
who inhabit Dejung,
the city accursed a thousand times,
the city of Horror and Deception,
the Seventh Wall of which
possesses a hidden entrance
into the land of the Yellow men.
He has trusted in the Demons
so that they continue his perverse work.
And They have enchained us
and prevent us returning to the world of Kus,
where is located the Palace
of the true God *HK*,
whose Name cannot be pronounced *without dying*.
But although Dejung is far away,
its Gates are everywhere.
Dejung has Seven Gates,
and Seven Walls surround it.
The demoness Dolma possesses the keys
but only the insane would let themselves
be guided by her.
How then will the valiant Kassites

lay siege to the fortress of Dejung?
If the Demons already know
of our holy purposes
and if their eye is fixed on us
from the Kampala tower?
We shall do so as our God Kus,
the Lord of Venus, taught to us,
awakening the miserable Enlil
from his dream and forcing him
to open the Gate of Heaven
and to lay the bridge
over the lugubrious walls
of Dejung Kampala.
Kassite Priests: Behold, all of you
that Enlil has awakened!
The God Who Sleeps is an idiot,
he likes flutes and drums,
dances and songs
and that they worship His Name,
but he also desires blood,
for El is the father of priests,
filthy shepherds, and sacrificers.
Only the *Pure Blood*
will bring forth the monster from the depths.
Proceed Priests!
Isa is willing
to die in war,
of all, the first!
I will travel through the worlds
where the dead watch
the Demons lurk
and the Gods await.
Kus will accompany me
to whom all respect.
And in the name of Nimrod
I will force the Beast
to open the Gates
for the good of our feat.
Proceed Priests,
Isa is ready!

At that moment, three things simultaneously happened: the Sun reached its zenith, the music abruptly ceased, inundating the ears with silence, and with an accurate stab wound the Priest cut short the life of the beautiful Kassite Princess. The jade knife cleanly slit her snow-like neck above the bi-cephalous necklace. Two Initiates held the lifeless body as the blood was gushing onto the glittering gem and into its uterine slit, now converted into an avid throat. Then the most marvelous things that human eyes had contemplated since many centuries ago began to occur.

Those who were within the turret were able to contemplate a terrifying scene: as the blood fell, the light that was emanating from the Emerald was extinguished for an instant, but then, like an arrow, a column of fire swiftly rose from the floor of the turret, enveloping the pedestal and the gem. The body of the Princess was lying on the ground, impossible to see under impenetrable clouds of geoplasmatic vapor that, at every instant, were becoming denser. Yet a spectral image, with her same naked beauty, could be clearly observed next to the column of fire, devoted to a kind of struggle. The fiery wonder, which at first was not exceeding the thickness of an elephant's leg, was now as wide as a circle of six men. Initially, it had fiercely writhed resembling an infernal ophidian, but then, when expanding, it was slowly adopting the unmistakable figure of the Dragon. It was a flaming Dragon whose frightful image was becoming sharper at every instant, insofar as the struggle was increasing with the phantasm of Princess Isa.

It is worth to clarify that only a few minutes had elapsed since the Princess expired up to the moment in which the monster of fire materialized. It is worth to clarify it because from there everything happened too rapid... or perhaps the witnesses lost sense of time.

Suddenly the jaws of that primitive beast, that Leviathan, Rahab, Behemoth, or Tehom-Tiamat exhaled a terrible roar, at the same time as an enormous blaze was sweeping the room, consuming and charring numerous Priests. Only the survivors could observe the incredible spectacle of that beast of fire *ridden* by the dead Priestess. Princess Isa, her phantasm, had climbed to the head of the monster, sitting herself between the triangular fins of the scaled back. That audacious action made the monster emit the infernal roar and the deadly flame. Not-

withstanding such a reaction and the ferocious shakes of the beast, the Princess was imperturbably repeating these words:

Spirit of Enlil, of El, of Yah and of Il
who fecundates the Earth
and produces life
and deceives men with your false opulence
and those illusory riches that you offer.
God, you who were once on high
but who have now fallen
and become a complete idiot,
do not also enchain us
in this infernal Universe
that you have constructed
imitating the true Heaven.

We will go

because we are fed up with you,
with all your traps,
and with the Demons who second you.
Open the entrance of the infernal cave
where your cowardly minions dwell!
El, I conjure you to do so
in the name of the true God,
father of Kus
to whom you betrayed!

By *HK!*

I conjure you to open the Gate
in the name of HK!

Upon hearing this Blessed Name, the beast instantly retreated toward the floor of the turret, coiling itself around the column of stone and metal. Its head, however, was menacingly swaying without this display affecting the poise of the spectral Priestess, who was firmly holding on to its back. The telluric Dragon was showing no intentions of obeying, an attitude that led the valorous Princess to act in a drastic manner. Leaning down, she stretched out her hand, making the gesture of touching her own blood in the full basin of the Hyperborean Emerald. Then she said:

This blood that today has been shed
 and toward which you have precipitated,
 Lord of all things,
 is my blood: a sacred blood
 of the lineage of the Gods of Venus.
 In it *is the remembrance*
 of our Divine Origin
 and the true God *HK*.
 With its substance I have anointed my fingers
 and now I will trace on your forehead
 the Sign of the Origin.
 Before it exists no defense.
 I conjure you to open the Gate
 Enlil, king of the Shepherds,
 by the Name of *HK*
 and the Sacred Sign!

The Princess rapidly drew its symbol on the forehead of the monster and behold, the greatest marvel had not yet been achieved. The horrible creature of fire shot upward, like a spring, going through the ceiling of the turret and carrying the beautiful rider on its head.

Those who were outside, in the corridors of the Ziggurat and around its base, were still silent, for only a few minutes had passed since the music ceased and because the terrifying roars that the monster, invisible to them, was emitting, were enough to silence any throat. At the moment that the Princess was drawing the primordial Sign and the Dragon was rising, a scream of fright came out from all mouths. Just above the turret, not much distance from its roof, the Sky ran as if a cloth had been torn.

A black opening was now clearly visible to all those who were witnessing the strange phenomenon. And the most curious and *abnormal* thing was that the dark hole *was totally hiding* the Sun, even though the Sun, for being much higher, *should be seen* from some distant angle. Nonetheless, no one saw the Sun anymore, although its light was still illuminating the midday as if it was at its zenith. It is comprehensible that, subjected to such intense emotions, no one was worried about the fate of the Sun since, while terror had paralyzed the cowardly Habirus, the Kassites were howling with fury, elevating their fists toward the heavens. It is just that the spectacle was

impressive and was justifying any distraction. The monster of fire, after the Gate of Heaven opened, had totally transformed. At first it seemed as if its frightful head had entered into the tenebrous opening since only a resplendent cylinder, like a beam of fire, was visible, which was emerging from the turret and going into the heights. But it was soon evident that a metamorphosis was occurring and after a few seconds a new marvel was offered to the amazed sight of the inhabitants of Borsippa. First, it became bulbous and covered with protuberances, while it was changing color and turning brown; then, very rapidly, the bulbs extended toward the outside and were transformed into sharp branches covered with pointed thorns and some green leaves; just a few seconds later, it was a gigantic hawthorn tree that was standing, unusually, over the Ziggurat of King Nimrod.

From the base of the Tower, only part of the trunk and the upper foliage was being seen, as the top was seeming to be lost inside *the Gate* of Heaven while the root was remaining hidden from view, in the interior of the turret. But what is worth emphasizing is that, as soon as the metamorphosis was completed, all vestige of fire, energy, or plasma disappeared, and the phenomenon was stabilized, producing no more changes. It was then seeming as if the hawthorn tree had always been there... were it not for the sinister tearing of the sky that was atrociously suggesting all kinds of abnormalities and alterations of the natural order.

But no one had sufficient time to be horrified. As soon as *Heaven* had *opened*, two figures velocrisly ran up to the last ramp, that which was leading to the terrace of the turret, and, already there, they drew their bows pointing toward the Threshold. They were Nimrod and Ninurta, the King and the brave General, the only warriors who were possessing the metal cuirass and who, for that reason, were advancing first, protected by the Elite archers.

The King and the General were pointing their bows toward the darkness of the opening trying to distinguish a target when, suddenly, two figures emerged brandishing a sword each. The Demons, with the appearance of a "White man," five cubits tall, were seeming to float in the air, but were somehow obtaining a foothold as they managed to bring down their swords on the heroic archers. The blades flashed when cutting through space but ricocheted without penetrating into the

cuirasses of Nimrod and Ninurta. However, the impact made them roll, stunned, off the roof of the turret that was serving as the last terrace.

A shower of arrows then rained upon the “Immortal Demons” and, although many of them ricocheted off their cuirasses, many others penetrated, riddling them with arrows. The badly wounded giants fell next to King Nimrod who rapidly decapitated them, holding up their enormous heads before the frenzied crowd.

While King Nimrod was doing this and then casting the bloody trophy toward the multitude, General Ninurta, accompanied by part of the warrior Elite, began to climb the Enlil tree that was uniting Heaven and Earth. For the first time in thousands of years, a group of Wise Warriors were preparing themselves to take Chang Shambhala by assault!

We beg the reader to permit us to make a brief stop in the story so that I may express in a poem what passes through my Spirit when evoking the last marvelous deed of that Hyperborean people who *knew what they were doing*, in the midst of a world that was pure confusion. Then we will pick the story back up at the precise moment in which the warriors of Nimrod were preparing themselves to invade the Threshold of the synarchic initiation.

Valorous Kassite warriors!
 His feat will eternally illuminate
 all the Hyperborean peoples
 who decide to take Heaven by assault
 and return to the primordial origin
 from which Jehovah Satan has deprived them.
 Because They have combated the Demons
 and awakened from the Great Deception.
 But so far no one has been able to
 match the glory of Nimrod, “the Defeated.”
 That is why those of us who remain here
 must attempt it again
 Together with Khristos LúCIFER “the Envoy.”
 The God of those who “lose” during the Kaly Yuga,
 and the monk warriors, the Hyperborean Siddhas
 who await the designated moment
 at which twelve men
 of the Purest Blood
 and one Siddha

will gather at the end of the Kaly Yuga
on American soil.
Then the Gral will be encountered
and after a thousand years of treasons,
the blindfold will fall from the eyes, awakening;
the Gate will once again be open
and Chang Shambhala with their Demons
will be definitively annihilated.
But so far no one has been able to
match the glory of Nimrod, “the Defeated.”
It is true that few attempted it:
some Iberians, some Celts,
Trojans, Achaeans, Dorians, or Romans,
many Goths and many Germanics.
But no one so far has been able to
match the glory of Nimrod “the Defeated.”
Perhaps the Cathars in Montsegur
or the Teutonic Knights
of Frederick II Hohenstaufen,
or the greatest of all,
our Führer, with his magic Axis
and a valorous people who back down at nothing;
perhaps He has sought it like no one else.
And thus many won eternity
and from this Hell they have marched.
But not definitively
for a Final Battle will be fought
and Nimrod will return
Together with the great Heroes of the past.
Odin, Wotan, and Wiracocha,
Heracles, Indra and Quetzalcoatl,
will arrive from Valhalla singing,
surrounded by exquisite Walkyries
and music of yore.
And They will raise enormous Armies
of the Living, Immortal and Resurrected.
Only one virtue will be demanded:
it is called *Honor* and it dignifies the Virya
who has awakened from the Deception.
The War will be Essential
and the Demiurge and his hosts, defeated,
will at last liberate the Eternal Spirits

who arrived from Venus
 so that they return where God awaits,
 in a World that has not been created.
 And upon departing from the Universe of Matter,
 of madness, of Evil and the Great Deception,
 those who return will sing in chorus
 the feats of Nimrod, "the Defeated"!

Let us now continue with the story. The Enlil tree was possessing spaced out and straight branches, which were in reality enormous spikes, so that it was able to be climbed by them as if it were a gigantic ladder. This was precisely what the valiant Kassites did, preparing to ascend by the tree and lay siege to the "Gate of Heaven." As soon as General Ninurta and fifty warriors had climbed high enough, they realized that they were in front of the entrance of a cavern, or the image of one. They audaciously leapt from the tree, without yet knowing if they could make footing in the mysterious world to which they were entering by the "Gate of Heaven," and found themselves on a clearly rocky ground. Some turned to look and saw the tree that was being lost in unfathomable heights; and also the edge of an abyss, a few cubits from where they were standing, through which was distinguished, many feet away: the roof of the turret from where the giant trunk was emerging; the Ziggurat; the men of the people gathered around; and the walled perimeter of the city of Borsippa. Contrasting with the intense exterior light, where it was still midday, a soft penumbra was reigning in that site. However, there was sufficient light, as to distinguish the details of the sinister cavern: seven stone steps were seen and, from the last, a passageway that was lost in the distance. But above the entrance, following the curve of its arch, seven triangular standards were nailed. Each one was bearing written the same legend, in many different languages. In their own Kassite language they could read:

Do not dare to set foot on this *threshold*
 if before you have not died to the passions
 and temptations of the World.
 Here one only arrives to be reborn
 as Initiates in the White Brotherhood,
 but to obtain such a privilege
 it is necessary to die first.
 Adepts: if you are still alive,

if the flame of primordial desire
 still burns in your hearts,
 if you preserve the *memory*
 and feed the *purpose*,
 then flee, while you have time!

It was evidently a strategic maneuver. The legend, apparently intended for presumed adepts of initiation, had as its objective to disconcert and provoke doubt in the intruders. However, far from achieving these ends, the message provoked instantaneous laughter in the Kassite warriors.

Nimrod and Ninurta were already climbing up the thorn tree, followed by another squad of archers. Soon they were reunited and, as nothing was occurring, they set out to enter into the infernal cavern.

“Isa, Isa!” King Nimrod began to call out, alarmed by the absence of the Priestess whom no one had seen since the Dragon was raised to Heaven. At that moment, someone noticed that the standards had erased their tempting message and were rewriting themselves on their own, persisting in that tactic of addressing the warriors with deceptively spiritual words:

Kassite travelers,
 whoever does not possess a just heart
 and a sweet and devoted soul
 capable of adoring the Great Architect of the Universe
 and serving Him in His Great Work,
 will only find madness in this place.
 You do not totally possess these virtues.
 Yet you are fortunate, Kassites!
 Although mistaken in your *purpose*,
 having known how to arrive here favors you
 and that is why we will make you an offer
for this one time only, now and forever:
 we offer you to serve, together with Us,
 The One, Lord of the Great Breath,
 Creator of Earth, the Sky and the Stars,
 of countless Worlds similar to this one,
 and of other *Lokas* so strange and subtle
 that they are inconceivable to any mortal.
 You are valiant and pure, Kassites,
 but you have been deceived by the Demon Kus

who showed you a non-existent Paradise.
 You must abandon it, and accept the Plan of The One.
 We now offer you *to pass the tests*
 and serve the One God at Our side.
 Think well Kassites,
 you have killed two of our *Hiwa Anakim*,
 the Sacred Guardians of the Threshold
 and that is a grave offense for which you must purge.
 However, we still offer you *to serve*,
 in the ranks of the Brotherhood, the only God.
 If you decide now, if you accept the deal,
 you must leave your weapons at the Threshold
 and strip yourselves of every aggressive intention,
and of the accursed signs that you carry.
 Do it soon, Kassites!
 For it is a unique opportunity that we give to you.
 Do it and you will be able to cross without danger
 the corridor that is before you.
 But bear in mind that you must cross it
 with repentance in the Soul
 because you will immediately arrive at a Very Holy place
 called “The Temple of Knowledge,”
 where you will be Initiated into the Mysteries of The
 One.

Nimrod and Ninurta hesitantly looked at each other; they
 were expecting to find enemies trained for combat but only
 stupid magic was there. The standards, with the words that
 have been seen, had mysteriously attracted the attention of the
 Kassites. Among the warriors, some did not know how to read,
 but, strangely, the message was still arriving to their minds.
 And, although they were not understanding many of the con-
 cepts used, *they knew* perfectly well that *buying them off*
 was being attempted, whenever an *offer* was being proposed to
 them; bribing them so that they abandoned the fight and sur-
 rendered themselves without presenting a battle. The Kassites
 defeated, disarmed with “words”? And what would be the
 price charged for such cowardly capitulation? Nothing less
 than to serve the hated Enlil? A murmur rose from the warrior
 Elite: an attempt was being made to deceive them and apart
 from that, their God Kus had been insulted. The blood was
 boiling in the veins of the heroic Kassites. But the message was
 continuing:

If you accept Our generous offer
 you will convert into *Warriors of the Rose*,
 you will learn the *Doctrine of the Heart*
 and, thanks to this Wisdom,
 you will discover El in your own Heart,
 that One by whom you are everything,
 the Ancient of Days,
 the Lord of Eternal Summers,
 the Kumara Sanat.
 If you accept, you will always fight for El
 and for His Chosen *Habiru* People,
 whose seed is very near to you.
 If you accept, you will return to the world
 as Adepts Initiated
 into the Mystery of the *Kalachakra*,
 the most powerful Science of Earth.
 And thanks to its secrets
 you will be the strongest men,
 you will have no enemies who can confront you.
 You will be respected Magicians,
 victorious Generals,
 invincible Kings,
 very rich men,
 depositaries of a Power
 as never before seen.
 You will share the glory of reigning in the World
 Together with the *lineage chosen by El*
 in the not-far-off day in which El,
 as YHVH-Satan
 will present Himself before numerous peoples,
 worshipers of Matter,
 and will lead them with a firm arm
 from the Synarchy of His Power...

“Nooo!” the voice of Nimrod resonated like thunder. “Do not look at the accursed standard! Its voice is outside, in the World of Deception. What does your Pure Blood tell you, Kas-site warriors? Did we not learn from Kus, the Hyperborean, that they would attempt to buy our arms? And did not Kus tell us, there in our distant mountains, that to cede to the Demons would be our end?”

He drew his sword and with a rapid movement inflicted a wound on his left hand.

“Listen,” he continued. “I, Nimrod, who has victoriously guided you into a thousand battles, tell you that we must combat these vile Demons, who dare not face us, to the death. I tell you that they lie and that with their promises they only seek to get us lost.” He raised his hand, from which was flowing abundant blood. “Here is my blood, which is the purest in the world! With it, I will trace the *HK* Sign on this infernal standard and then we will enter to slay the Demons. Our Sign is invincible!”

With his right thumb, soaked in blood, he drew the Sign of the Origin and it instantaneously seemed as if a fire consumed the seven enchanted triangles.

“Let us kill the demons!” shouted all the warriors in chorus.

However, they did not manage to enter the tunnel. The remains of the standards were still smoking on the ground when the Demons of Shambhala, who were secretly observing the reaction of the Kassites, were getting ready to use one of their terrible Atlantean weapons: the “*OM* cannon.” First, it was a soft sound, penetrating and acute, like the singing of the cicada. Then it began to raise in pitch and volume until it became irresistible.

“Isa, Isa!” shouted Nimrod and Ninurta, in duet. Effectively, descending from on high by the thorns of the Enlil tree, the specter of the Kassite princess was in sight. She was staring at them and was seeming to energetically speak but, at first, no one heard anything, since the intensely emitted monosyllable of *El* had almost stunned everyone. However, the faith that the Kassites were feeling for the Priestess of Kus was impressive and perhaps this confidence made that they soon heard, or believed to hear, her instructions.

“Stand behind Nimrod and Ninurta! Fixedly observe the *HK* Sign that they have engraved on their backs and let the Voice of the Blood flow in you. Its murmur will extinguish anything that perturbs you. And you, valiant Chiefs: you have a powerful weapon; you will see that it protects you. Look to me and trust, that soon your pain will cease.”

Taking a leap to the King and the General, the Priestess put her hands on the heads of those Heroes, producing the exaltation of one like a brilliant aura around their bodies. This operation produced evident relief because a second later both were cursing, even though they were still not able to hear their own oaths.

While the events that I just narrated were occurring in Heaven, below, next to the Ziggurat, the rest of the people were living curious experiences. When Nimrod threw the heads of the Demons, the uproar was very great and a short time later they were hanging skewered on spears. These heads were quite larger than those of a normal man, although they were not doubling it in volume. The long and blond hair was framing a square face, with slanted and black eyes and an enormous hooked nose. The mouth was of full lips, a detail that was perfectly being noticed, since the Demons were lacking beards.

The pikes were thrust before the image of Kus while the Initiates were transporting the enormous bodies to proceed, before the God of Race, to tear out the heart of the Demons. One Priestess made the opening in the white chest and extracted the heart, which was curiously located on the right side. Then she removed the organ from the other demon and elevated the bloody viscera in her hands for the people to see. And here occurred an umpteenth marvel for, upon contact with the air, the hearts were transformed into flowers, with the consequent fright on the part of the crowd made up of men and boys. They were two *red roses*, each with a piece of thorny stem, but no one recognized them as such, since roses were not yet existing on earth, and it is probable that those were the first ones that human eyes were seeing since the sinking of the last Atlantis. The Priestess contemptuously threw them at the feet of Kus and they all returned to the Ziggurat where, in that endless midday, the gigantic hawthorn was standing.

The Elite of two hundred archers had already climbed the Enlil hawthorn and penetrated into the black opening. The rest of the Kassite Army was remaining around the Ziggurat: the infantry, the sappers, the lancers and auxiliaries, and numerous archers who were not belonging to the Elite. There were also several squads of warriors from other cities who had come to Borsippa as escorts of Ambassadors and Nobles. And they were all raising their fists toward Heaven and shouting: "Kus, Nimrod! Kus, Nimrod!" encouraging their now invisible King and intimately desiring to receive the order to climb the hawthorn to collaborate in the fight. Several Princes and military Chiefs were with the troops, but no one would have dared to give any order without first receiving signals from Nimrod or Ninurta.

A chorus of women and children, who comprised the rest of the people, was accompanying the shouting of the troops. But the *Habiru* shepherds, of course, were continuing frightened, in a low voice invoking Yah, El, Il, Enlil, their beloved Demiurge. And the Initiates, who had first, timidly, and then with some urgency, climbed the upper turret to inquire about the fate of the Hierophants, were finding that they had all perished. And that is why they were crying aloud and cursing the sinister hawthorn. For the Initiates who did not die when the terrible tongue of flame scorched the turret were now skewered on thick and long spikes that were covering the totality of the blue enclosure. The Kassite people had lost the Elite of Cainite Initiates; their fate was now solely in the hands of King Nimrod!

But then, the sound of the *OM* cannon began to invade the ambit of the city and soon became so unbearable that many fell to the ground, fainted from pain. A new cloud of geoplastic vapor, now erupting from the ground of Borsippa, spread rapidly. The mist rose to a height equal to half a man and covered those who unconsciously collapsed. The first to go down, almost instantaneously, were the Habiru; men and women, children and elderly, all fell on the spot, struck down by the penetrating sound. And next occurred, perhaps, the *penultimate* great phenomenon of that glorious day.

Suddenly, as mysteriously as it had formed, the mist began to dissipate, revealing numerous men and women who were lying on the ground or who were attempting to get up. But the marvel was that the Habiru, *in their totality*, had disappeared. And the diabolical sound, the monosyllable of El, also ceased at that moment.

The Kassites, when verifying that the Habiru were not in sight, thought that they had fled since many of them were their slaves or servants and this presumption was increasing their rage. But the Habiru had not fled: their entire community experienced the selective effects of the *OM* cannon, the sound of which, properly tuned, has the property of producing teleportation. In different places, at a distance of many miles, the Habiru shepherds “found themselves” upon regaining consciousness and while they were at first cursing Nimrod and his “magic,” attributing to him the blame for their involuntary journeys, upon hearing news of the fate of Borsippa, they thanked their God Yah for having saved them. Many awoke in

Nineveh or Assur, but others ended up in sites as far away as *Ishbak*,¹⁶ *Peleg*,¹⁷ *Serug*,¹⁸ *Tadmur*,¹⁹ or *Shinar*. In fact, many families took years to reunite, separated by distances of two or three hundred miles, which contributed to disseminate, in a distorted manner, the feat of Nimrod in the Middle East. To all this, in Borsippa, an archer peeked through the black opening of the sky and shouted:

“Warriors, to the attack! Nimrod wins!”

This call was longed for by the Kassite people and caused, an instant later, thousands of warriors to launch an assault on Heaven.

But let us return to the entrance of the cavern, where Nimrod and Ninurta left off. When Nimrod and Ninurta were convinced that the *OM* sonic ray could not counter them, they prepared to invade the Threshold. The corridor was sufficiently wide so that they were able to advance five at a time, which they did at full speed. In front was the spectral figure of Princess Isa, followed by Nimrod, Ninurta, and the rest of the archers, except for a dozen who remained on guard at the entrance. That cavern, constructed with the aim of frightening those aspirants into serving the Demiurge, had the walls covered with monstrous bas-reliefs and mysterious and impious legends. There were also side doors that were leading to certain “chambers” where the Demoneess Dolma is usually present in her lascivious nakedness, surrounded by a court of prostitute Priestesses. She is in charge of “guiding” and “bewitching” the adepts who ignore the dangers of sexual magic.

These, and many other hallucinatory traps, intended to confuse and subdue the will of the naïve aspirants who usually venture across the Threshold, were mounted, looming, throughout the endless length of the sinister corridor. But none of such tricks could detain those who were beyond the senses; those who were only hearing the Voice of the Pure

16. A Northern Arabian tribe said to have originated from Ishbak, the fifth son of Abraham and Keturah.

17. Corresponds to the city of Phaliga (Circesium) at the confluence of the Euphrates and Chaboras rivers and Serug’s grandfather, Peleg.

18. Corresponds to the city of Šarugi (modern-day Suruç) and Abraham’s great-grandfather, Serug.

19. Corresponds to the region of modern-day Palmyra, Syria.

Blood; those whom their determination had led them to fight in Heaven.

The Kassite vanguard had covered a length of two stadiums when the tunnel abruptly concluded, revealing three halls, one after the other, at which entrances large inscriptions in various languages, were letting them know that they were in the “Temple of Ignorance and Learning” or in the “Temple of Fraternity” or in the “Temple of Knowledge.” The first hall was empty, except for an altar with the odious symbols of Enlil. The second was possessing two altars and two enormous basalt columns at its entrance. The third was boasting a sumptuous altar with a coffin and, engraved on the walls and ceilings, the most obscene and accursed symbols that anyone could conceive without going mad. And all the halls had rich carpets and tapestries covering the floors and walls, and aromatics that were pervading the space, softly illuminated by various oil lamps. The three halls, so curiously decorated, were undoubtedly constituting an unusual spectacle for those hardened men, who minutes before were finding themselves in a humble desert city. However, these strange rooms were not able to be duly appreciated by the Kassites, for the fight began as soon as they entered into the first hall. There, a group of “Guardians of the Threshold,” *Hiwa Anakim*, similar to those who Nimrod decapitated moments before, were blocking their way.

Despite possessing a fierce appearance, and being quite large in size, those spawns of black magic are not very effective at fighting. They have been born from the copulation between the Siddhas of the Dark Side and the Paśu females in the Sabbath ceremony, which is very ancient, from the epoch in which said practices destroyed Atlantis. Many thousands of such demonic beings live in Chang Shambhala (or Kampala or Dejung, etc.), are totally imbecilic and serve in the “Armies” of the Great White Brotherhood. However, there are persons more imbecilic than the *Hiwa Anakim*: they are those who, upon seeing them, take them for “Angels” or “extraterrestrials.”

The Guardians were surrounding a bald, half-naked, elder of Yellow race, who was seeming an inhabitant of the distant Kuenluen Mountains. He had in his hands a *Dorje* or Scepter of Power, that is, a very powerful transducer that allows to operate as a “key” or “trigger” in all the great resonant machinery that is the material Universe. The Scepter, a rod with a spheri-

cal head of stone, emitted a reddish ray that curtly struck the chest of General Ninurta, knocking him to the floor. But the Enemy had no time to be happy about this blow, for a well-aimed arrow pierced the heart of the yellow Demon provoking, such an extraordinary response, great confusion among the Hiwa Anakim. Now the clash became inevitable; while some Demons were dragging the cadaver of the old man toward the "Hall of Learning," others were heading, sword in hand, toward the Kassite warriors. A hail of magic arrows fell upon them, but the distance in such a confined environment was soon shortened and one had to fight hand-to-hand. Several demons had already fallen and some more did not take long in following them, due to the effect of the Kassite swords. Nimrod opened a clearing between the attackers and, followed by his squad, passed into the next hall. There the fighting became fierce and it was seen that the number of Demons was very great.

But Nimrod was fervent. He had distinguished, across the second hall, a resplendent personage, who was directing the attack. At times he was peering into the Temple of Knowledge from a door that was seeming to lead into a wide courtyard, but he was stepping aside after shouting orders to make way for other clumsy Hiwa Anakim. He was a Nephilim, a Siddha of the Dark Side, but Nimrod, impressed by his Divine appearance and his great white wings, took him for Enlil himself. He carefully aimed and shot when the image of the Nephilim appeared in the doorway. The arrow traced a smooth curve in space and went directly for the chest of the Demon, ricocheting as if it had hit against a rock.

"Nimrod, you dog!" shouted the Nephilim with his face disfigured by hatred. "You respond to our offer like this? Now you will die, you and all your folk. You will be fodder for our Hiwa Anakim who, by the way, have a good appetite."

Having said this, he stepped aside from the doorway, as a throng of Demons burst toward Nimrod while he was observing, horrified, as many Hiwa Anakim were giving themselves over to ferociously devour the fallen warriors. This sight drew a cry of horror from the Kassite King and as his sword was keeping the attackers at bay, he was observing that the casualties were terrible among his Elite archers. That was the moment in which he gave the order to seek reinforcements. A few

moments later, thousands of warriors were bursting into the accursed Temples of synarchic initiation.

Soon the Hiwa Anakim were overrun and Nimrod had time to gather his surviving archers. Less than half were left but the arrived reinforcements were impressive, to the extent that they were threatening to saturate the three Temples that had already been taken. It was necessary to attempt an exit toward the exterior courtyard. Nimrod spied through the door in which he saw the Nephilim and verified that it was leading to the courtyard of an enormous Palace, in the middle of a cyclopean city. A picture that was breathtaking.

They were in the heart of Chang Shambhala, very near to the Palace of the King of the World. The conjuration of the Cainite Initiates had been so effective, supported, of course, by the Mystery of the Pure Blood, that the Serpent of Fire had leveled the Seven Walls for them. The tunnel of the synarchic initiation runs through them, so that the disciples of the Demiurge can arrive to the Masters of Wisdom. But it is worthwhile to make some clarifications. In spite of all that the Cainite Initiates and Nimrod have been seen to do, the key to arrive at Chang Shambhala is not magic, but Strategy. It would be worthless if someone could “open the gate,” if his Spirit is dogmatized or is a victim of any of the psychological tactics that the White Brotherhood uses to achieve the Universal Synarchy. That is why *the true feat of Nimrod was to go through the tunnel and the three Temples* with weapons in hand, which speaks, and will forever speak, of the Purest Blood of Earth. For these places *are the most powerful chambers of deception that exist in the world*. Nothing can match them, neither the treatments with drugs that the Secret Services of the West may use, completed with hypnosis, nor any other system of “psychic programming.” Those who end up there, useful persons to the Synarchy, Heads of State, the religious, Kings, rich and influential persons, presidents of corporations, etc., “return completely spellbound, prepared to fully work to fulfill their mission.” They are the “Initiates” of the Synarchy, they have “died” and “returned” to “be born”; but in reality what has died in them is the Spirit, the Memory of Blood, which now, submerged in a total *strategic confusion, they will never feel* again.

In the courtyard exterior to the Temple of Knowledge, where the valiant Kassites had barricaded themselves, a whole legion of Hiwa Anakim, sword in hand, and several squads of

Shedim, the earthy-skinned dwarves, were restlessly waiting. These dwarves, of enormous heads, are the product of ritual copulation between men and certain animals, during the orgies of Atlantean black magic. Transported en masse to Chang Shambhala, after the hecatomb, they inhabit lugubrious caverns and perform all sorts of tasks for the “Masters.” Lately they have been “re-discovered” in the West as accompaniers of UFO crews, but, in truth, they are a millenary terrestrial species. They are in control of a paralyzing anti-personnel weapon that gives a cold sensation and can produce fainting spells but which is not lethal. They present themselves aggressively and are to be feared if one does not know them and does not have the necessary knowledge to neutralize them. But when they are losing, they are cowardly and flee in disarray. They are ferocious carnivores but do not like human flesh as the ferocious Hiwa Anakim do. They are those responsible for the theft of cattle, mutilations of animals, and blood suction, just as the Hiwa Anakim usually have breakfast with unsuspecting citizens who never “reappear.”

The sight of the exterior courtyard was not able to be more eerie, but Nimrod was desiring to confront the cowardly Nephilim and avenge the horrific casualties produced among his men by the anthropophagous giants. For it, he devised a simple Strategy. He would send the infantry in a horde followed by a vanguard of lancers. Behind would be the Elite archers protecting the rearguard and permanently firing at the surest targets. In the confusion, Nimrod would attempt to arrive at the Nephilim.

The Emim Nephilim whose name was *Kokabiel*, one of the two hundred Hyperborean Siddhas who came from Venus, followed the Path of the Right Hand and founded the White Brotherhood or Occult Hierarchy of Earth, was directing his nightmarish hosts shielded behind an enormous spouting fountain. His presence was dazzling, for these demons are proud and feel pleasure at showing a beautiful appearance, vainly trying to compete with Khristos LúCIFER, the Lord of Un-created Beauty.

Nimrod gave the order to attack and a horde of Kassite warriors precipitated against the tight formation of Demons. The dwarves fired their “belt” weapons and produced some stumbles among the first warriors, but it was soon seen that the impetus that they were carrying would make it impossible to stop

them in that way. Dozens of arrows began to rain down at the same time that the two vanguards were colliding, generating a tremendous skirmish. At that moment, Nimrod, who had apparently headed in the opposite direction, dropped, in two leaps, onto Kokabiel, attempting to slit his throat with a sharp Jade dagger. That weapon, coming from China, Isa had recommended as very effective for taking down Demons.

Rolling in deadly embrace, two enemy Hyperboreans, the white Nimrod and the tenebrous Kokabiel, were gambling their immortal and illusory lives trying to stab each other. It was something that was not seen since 8,000 years ago.

But their bodies were belonging to two different Races. Kokabiel was enormous, almost double the size of the valourous Nimrod, and that physical advantage, added to his hatred that was constituting an almost palpable energy, burning, placing the Kassite King in trouble.

“Die, Dog Nimrod!” shouted the Nephilim while pressing on the neck of the Kassite King, caught in a deadly fighting hold.

“Die and return to the infernal world of mortal humans!” The bones of the unfortunate King began to crack.

“Imbecile Nimrod! You were wishing to conquer Heaven? The punishment will be terrible. We will enchain you in such a way that you will return to mineral consciousness or, even worse, to the elemental world of etheric larvae. And you will take millennia to remove the wheel of Karma, accursed Nimrod. And we will teach your people a definitive lesson. They will be wiped off the face of the Earth! But your defeat will always be remembered by the *Habiru* lineage of *YHVH*.”

Crack! The spine of Nimrod lugubriously sounded upon breaking.

“Ha, ha, ha,” Kokabiel was cynically laughing. “That name really suits you well: ‘Nimrod, the Defeated.’ So shall you be remembered, dog Nimrod. Ha, Ha, Ha. *Ahhha!*” howled the Nephilim horribly upon noticing that the jade knife had penetrated into his waist at the hilt.

At every moment of the struggle, Nimrod had tried to plunge the weapon but it was slipping on the electrostatic cuirass with mineral precipitation that was protecting him. At last, when he felt himself dying, he diffused his consciousness into the Blood, in the Hyperborean manner, and let the last effort of his arm be guided by primordial impulses. And then

his hand, fearsomely armed, directly thrust to a point on the waist of the Nephilim, just above the liver, where a chakra vortex was generating a weak point in his armor.

Now Kokabiel was dead, and would never again live in this Universe, such is the mystery that the Nephilim Demons of Chang Shambhala try to hide. But Nimrod was dying next to the gigantic corpse...

Upon Kokabiel falling, a sudden disconcertion was generated among the demonic hosts. Nevertheless, the voices of other cowardly Nephilim were inciting them to fight without retreating. The massacre was terrible and blood already covered a large part of the courtyard, strewn with hundreds of cadavers. A squad of sappers began to set fire to the adjacent corridors and soon burned the Palace that was, evidently, evacuated. In the midst of the confusion, some warriors sat the archer King against the rumbling fountain and saw him smile as the flickering of the voracious tongues of fire were projecting dancing shadows upon his face. They also saw him speak with the specter of Isa. Some were even able to hear what they were saying with clarity:

“O Isa. Where have you been, Princess?”

“Very far away, Valorous Nimrod,” responded the dead Priestess. “The monster of fire, Enlil, transported me outside of the terrestrial world, to the House of his Master Shamash, the Sun. There I saw a City of Fire, with the most infernal Demons that anyone can imagine. There were eleven ‘Gods’ similar to Enlil. And one, O Nimrod, who cannot be described by any mortal without running the risk of losing his sanity. The most hideous and abominable monster that can be imagined in an eternity of madness. And He was inhabiting Shamash! And everything, O Nimrod, every existent thing, all that we saw here, in this Hell, and in many other worlds that the monster traversed, all of it was alive, was palpitating, and was part of Him!

“But you ought to rejoice, O Nimrod, for not even He could withstand the primordial sign of *HK*. ‘Turn yourself into a tree,’ ordered Shamash to the Enlil Dragon, ‘and confuse that *Sign* that reminds us of the *Incognizable* in the primordial gnosis of your fruits!’

“Suddenly, O Nimrod, I found myself at the top of a thorn tree that was hanging from black abysses and was reaching as far Shamash. I began to descend and many infernal creatures

were stalking me, but they all fled when realizing that I was carrying the Sign. I was very concerned since I had to fulfill the mission of finding the Path of Return to the Origin, just as it was entrusted to us by the Cainite Sages. All the hope of the Race was put on me and I could not fail. And to top it all off, I was perceiving the Voice of Shamash who was speaking to the *Dog of Heaven* and was saying:

‘O Sirius! O Zion! O Divine Canid! Your never-sullied Face must contemplate how the followers of Khristos LúCIFer, the envoy of the Incognizable, rise up against the Plan of The One, defying the cosmic laws and seeking to abandon the Universe of the Suns. Will we, the Architects of All Worlds, permit that the *enslaved Spirits* liberate themselves from the yoke of the cycles, the manvantaras and the pralayas? Respond, O Thou, who dwell in the Peace of The One. Tell us if we can accept that the anointed LúCIFer, the Khristos, reveals the Mystery of the Vril to the Spirits bound to the evolution of our Holy Wills. For behold, The Envoy has established himself in our Mansion, and from there he encourages the Redemption of the Pure Blood. He illuminates the interiors of the Viryas with a *new Sun that no one sees*, a Black Sun that remembers the divine origin of the Spirit and awakens the Nostalgia for the Return. Shall we permit this abomination, O Sirius? If they discover the path of Return to the Uncreated Worlds, what will become of our planetary chains, entrusted to the dubious development of the monads? We must prevent it! O Sirius-Zion, Dog of the One Shepherd who looks after the Cosmic Flock, sink your teeth into the Redeeming Serpent and deliver us from the threat of spiritual liberation *so that the slavery of those who are similar to the Incognizable, without knowing what they are, eternally continues!*

“O Nimrod, fear not!” exclaimed the Princess upon realizing that the face of the dying Kassite King was casting a shadow. “We have triumphed, O Thou, vanquisher of Kokabiel! While the Demons were making their blasphemous voices heard throughout the orb, I was trying to comply with the mission of the Race and find the Path of Return. For it, I was concentrating my attention on the Black Sun, since that is the only way to preserve the *strategic advantage* obtained by the purity of blood, when a very vivid light came from behind that Racial Center. It was a *green ray*, of an ineffable purity, which was passing through the Uncreated Center and was revealing, to

our Stirp, the Original Gate of the Lost Mansions. O Nimrod, in an instant everything became clear, all confusion dissipated! I could no longer ever lose myself because now I knew that we had never strayed, or been confused, or sinned, or fallen. We had never even moved. O Nimrod! By dissipating the totality of the Great Deception, I have had the certainty that we would no longer have to return because we were there without knowing it. We have conquered the Freedom of the Spirit, Valiant Nimrod! *And the absolute possibility of being ourselves, our own creation, of being us, the womb of our own birth. It is the Will of the Incognizable, Divine Nimrod, that we can do all things!*"

Princess Isa pronounced her last words, accompanying the final sigh of the Hyperborean King: "I was already in possession of the Secret of the Return upon descending from the hawthorn, when I saw thee at the entrance of the infamous initiatic cavern, but it was good to give proof of the purity attained by the lineage of Kus, that the Final Battle was fought between the Kassites of Nimrod and the Demons of Chang Shambhala. So that the memory of this feat lives on in the racial memory of the Viryas still enchained and is evoked at the end of the Era of the Fish, when the Thirteen Siddhas recover the Crown of LúCIFER and definitively awaken the Hyperborean peoples. Then Chang Shambhala will fall with its demons, and in an endless Holocaust of Fire, the accursed work of the Demiurge Jehovah Satan will succumb."

Nimrod was lying dead in Chang Shambhala. Next to him, with a grimace of unspeakable horror on his taut face, was the cadaver of the Nephilim Kokabiel, who had been Master of sorcerers and magicians. His Science had proved useless before the tenacious determination of the pure Kassites and said failure demonstrated that for the Virya, transmuted into a Siddha, it is always possible to fight against the Demons and win. Of course, that *mystical victory* can also be a defeat, if it is *measured with the rod of the Paśu*. Because, in fact, any victory that does not bring about a material success, verifiable by the moral standards of "synarchized" societies, is considered as a "defeat." For the morality of a society is a function of its Culture and, as already seen, "Culture is a strategic weapon" for the Synarchy. That is why those who fight against the satanic forces, the Hyperborean Viryas, will always be branded as "defeated." And that is why the Great Being who illuminates the *Interior Path* of the Viryas, Khristos LúCIFER, is called the God

of the Losers: because all his followers always “lose” during the Kaly Yuga.

So Nimrod, the Defeated, was lying dead in Chang Shambhala. His brave Kassites had been completely exterminated in a vast area of the Accursed City, to where their warrior fury led them. In the reverberating light of the recent fires, the frightful ossuary into which the Temples and courtyards were turned was able to be observed. The first Palace, called “Mansion of the Manus,” where the annals of the Root Races were being deposited and that was utilized by the Masters of Wisdom to train their *envoys*, was reduced to ashes. An enormous Monastery and various shrines dedicated to “minor divinities,” always used for training “envoys,” in other words, to tactically deceive them, also suffered the effects of the fire. Compared to these important losses, the resistance offered by the Demons had been minimal. Only the vile Kokabiel and the Chinese Master who used the Dorje risked their skins, limiting themselves to sending legions of Hiwa Anakim giants and Shedim dwarves against the Kassite warriors. As it would be said now, they utilized a “mass tactic” comprised of “robots” or “androids.” It is that *they cannot risk their lives since they are too few*. Millions of years ago they were two hundred. Nimrod liquidated one... Surely it is hard to believe that so few are capable of so much. But it must be considered that They possess the “support” of thousands of “Masters,” that is to say, of Paśu “Initiates,” Souls of superior evolutive degree, and rely on the *strategic dominion of the planetary consciousness*.

That endless “midday” remained unaltered throughout the Battle of Nimrod, and one can consider its approximate length as about twelve hours. At the moment in which the Kassite King was expiring and the combat in Chang Shambhala was being extinguished, the *last marvel* was shaking Borsippa. All the available warriors had already ascended to Heaven, more than four thousand, including some visitors, and the city was then presenting a strange appearance. With that crowd mostly comprised of women and children who were not ceasing to shout, superimposing their protests on a background of war music played by the Cainite Initiates. And that imposing tower, raised up to Heaven in open defiance. And that hawthorn tree at its summit, that pinkish tree that symbolizes the sublimation of matter by El and its fitting into the Cosmic Hierarchies, whose supreme regent is He who denominates Himself

"*The One.*" And that endless midday, without the image of Shamash... Truly, Borsippa was presenting a rare appearance on that, its last day!

There were no longer Semites in Borsippa; the lineage of Yah, the blood of Abram, the Habiru shepherds, would be saved. But neither were there cowards to flee when the *silver lentil* appeared in the heavens. All were dumbstruck as the great *silver eye* was emerging from a suspicious cloud. And they all died at their posts when the atomic ray fully hit the Tower of Nimrod. The developed heat was so tremendous that the sand was melting and dripping like water. A deadly hurricane, an expansive circle of fire, spread from Borsippa killing any living thing within ten miles.

Another of the Atlantean tactical weapons was used, thus giving fulfillment to the plea that Enlil and Shamash made to the Dog of Heaven, Sirius-Zion, and that Princess Isa witnessed. And once the attack consummated, the silver lenticule disappeared from all physical sight to return to the *center* from where it had been *projected*, in Chang Shambhala.

When the smoke dissipated, only one-seventh of the Tower of Nimrod was standing upright; Shamash was continuing its journey toward the west and the hawthorn tree and the Gate of Heaven were no longer existing. The nightmare had ended: the Threshold was safe to continue providing its services to the synarchic initiations and the Sons of the Midnight Sun had failed again.

Only the racial memory of the great feat of Nimrod and the charred remains of his Tower would be left, just as can still be seen today at the Tower of Borsippa, with the sand vitrified by the nuclear heat still adhered, after millennia, to its walls. And the calumnies invented by the Habiru shepherds and included in the Arab and Jewish tradition would also live on. In the Talmud and in various rabbinical writings, part of this story can be read, conveniently altered. Mentioned there are the Tower of Nimrod "from which his archers were shooting arrows at Heaven," the "luciferic pride" of the Kassite King, his Tower "confused" with that of Babel, etc. Clay tablets engraved in cuneiform script have also been found, which tell the facts more objectively, and numerous Kudurrus, engraved stones that used to be placed in Temples or as territorial boundaries, with references to the feat of Nimrod.

Perhaps of all the falsifications made about this Hyperborean deed, the most insidious is the reference from H. P. Blavatsky in her Secret Doctrine, where it is written that “an elite of Assyro-Babylonian priests discovered the way to escape the Plan of Evolution of the Solar Logos and abandoned the Planetary Chain, together with their people, heading to the ‘stars,’ *where they continue their evolution.*” That is to say that the mentioned agent of the Synarchy intends to capitalize on the feat of Nimrod *in favor of synarchic theories.*

The rest of the Kassite people continued dominating for a while but finally merged with their Hittite cousins for, it has been already said, “a Race that loses its Cainite Initiates is a dying Race.” and, together with Nimrod, the Elite Cainite Initiates had departed forever. However, the Hittite expansion led to re-inhabiting Borsippa, which was reconstructed in part, but no one dared to touch the ruins of the terrible Tower.

In Chang Shambhala, the history of Nimrod is always present and with the order to prevent future attempts of this type, many “envoys” have occupied themselves for centuries with *eliminating* evidence in this respect and to *confuse* about the tactical methodology used in the attack. As we shall see later on, only in the twentieth century, through the work of the Führer of Germany has it been possible, with prospects of success, to once again undertake the collective mutation of the Race and attempt the conquest of Heaven. *But the results of this new Hyperborean deed will surely appear, to those who are under the effects of Synarchic Magic, as a “defeat.”*

To conclude this summary of the history of Nimrod, I will say that the Kassite King, his brave General Ninurta, his Priests, and all the people who died in Borsippa, undertook the definitive *Path of Return* guided by the indomitable Princess Isa.

In the meantime, the idiot Hiwa Anakim Demons were devouring their bodies in Chang Shambhala and the King of the World was pronouncing his vespertine Prayer, delayed twelve hours that day by the unerasable feat of Nimrod.

In a Buenos Aires museum, in Argentina is found the famous Kudurru of Kashshu, discovered in Susa, where it was part of the plunder of the Elamite King Shutruk-Nakhunte of the twelfth century BC. On it is engraved the regal figure of Nimrod *treading on the Moon and the Sun*, and with an eight-pointed star, symbol of the planet Venus, above his head. Next

to him, a Ziggurat, reminiscent of his famous Tower. Below this image there are two columns of cuneiform script in the Hittite language where is mentioned the death of the King and it is warned that no one must forget his feat. I will transcribe part of said text according to the erudite version of Professor Ramirez of the University of Salta, universally considered as the most exact:

The Death of Nimrod

From a famous Tower
the ruins of which are here
King Nimrod has departed to Heaven.
One day he will return!
But he has not gone
to the Gods to bend his knee.
With bow drawn he has gone up
ready to kill.
His arrows have wounded Shamash
but he has soon managed to heal.
But Nimrod has gone
although someday he will return.
A Goddess guides him,
She is called Isa,
She is Ishtar herself,
and a people accompany him,
they are the brave Kassites
who will fight alongside him.
For Nimrod has departed
and is no longer with us,
although the legends say
that one day he will return
with his bow drawn
ready to kill.

The Thule Project of John Dee



It is only now, after we have interiorized the venture undertaken by Nimrod and his Kassite people in the ancient Assyrian city of Borsippa, that we can attempt to describe, superficially, the Thule Project of Dr. John Dee. But we must first bear in mind that said plan was not realized and presented at a given moment, but rather we denominate “Project Thule” to a series of indications that Dr. John Dee made to Queen Elizabeth I between 1581 and 1587, being in the last years of this period when his clearly Hyperborean character was revealed. The possession of Princess Papan’s mirror allowed the English sage to elaborate a Hyperborean Strategy so advanced for his time that it could only be fully understood in the nineteenth century. But this Strategy was developed and transcribed in the Enochian language and in this form it reached our time. Only a part of it was adapted to the exterior politics of England, to the reality of the sixteenth century, and presented to Elizabeth I in the famous Thule Project; the rest was made up of universal principles of the Hyperborean Wisdom applicable in any time and place; for which reason, if they were known now, they would seem curiously *current*. We can then summarize the steps of this Strategy without forgetting that it is *part* of a General or Totalizing Strategy; and that said *part* was never presented complete, just as we now analyze it, but in successive “suggestions.”

I. *Background*

Thanks to the friendship that John Dee was maintaining with Mercator,²⁰ whom he met in *Leuven*, he was able to obtain, for England, terrestrial globes designed with his famous projection system, as well as various instruments for navigation. As is well known, the sixteenth century began with Spain and Portugal holding a tremendous maritime superiority over the other countries of Europe, and ended with the sinking of the Invincible Armada, an event that marked the beginning of English maritime expansion. Dr. John Dee contributed to this change of situation, undoubtedly due to the iron hand of Elizabeth I, with several scientific contributions. In the sixteenth

20. Gerardus Mercator

century, a map or a new astrolabe were considered state secrets, since their exclusive possession could mean, in many cases, years of advancement over other nations. It was the century of America's conquest and of multiple world maritime explorations.

In this historical framework of wars for maritime predominance and fierce commercial competition between countries, the strange life of Dr. John Dee must be inscribed, so as to grasp the originality that his "indications" and "suggestions" made to Queen Elizabeth I represent. *Firstly*, he informed the latter that the Mercator projection was suffering from serious errors originated in an incorrect use of geometry and mathematics. According to the wise Englishman, "*another geometry*" should be investigated, such a one that enables the interpretation of certain strange characteristics that geography presents in some places of the Earth." These abnormal characteristics were derived from a new model of the world that John Dee had obtained by "revelation" from the angels who were speaking to him through the magic mirror. And in this way he was 300 years ahead of the idea that, in order to interpret actual space, it was necessary to resort to another geometry different from the Euclidean one.

Secondly, his accurate indication that Greenland is one of the key places on Earth, due to the special characteristics that space was acquiring there, should be emphasized. John Dee's theory, evidently inspired by the Hyperborean Wisdom, was affirming that terrestrial space was made up of various concentrically superimposed planes, like the layers of an onion, which were true unknown worlds in themselves. In some special places said planes would be "in contact" with each other, there being true "doors" that would allow entering into them. For this reason, because of the special conditions that Greenland would possess in order to initiate such explorations, John Dee, in a writing that is still kept on file in England, was calling the icy territory as a "door toward other worlds."

Thirdly, Dr. John Dee pointed out to the sovereignty that, since the tenth century, a suspicious maritime movement had led the Icelandic *Vikings* to settle in Greenland. And it was known that the Norwegians, Swedes or Danes, as well as the Normans of France and even the Irish, were in possession of legends about marvelous and paradisiacal lands that were "beyond Greenland" and that they or their ancestors would

have visited. After the discovery of America, it was universally thought that said fabled lands, the legendary Vinland for example, were in the New World. But John Dee was not thinking that way. According to his criterion, the audacious explorers would have also followed a northern route within Greenland itself that made it possible for them to arrive at “other worlds,” which does not invalidate the fact that they also knew of and explored America. It is fair that when the existence of the immense and rich continent located exactly to the west was made public, no one bothered to establish the veracity of some unknown lands located in the dangerous Greenlandic north. But neither could anyone deny to the astute English sage the disturbing and inexplicable fact that *the entire Viking population of Greenland*—some ten thousand people in the thirteenth century—*had disappeared without a trace by the fifteenth century.*

In effect, as Jacques de Mahieu points out:

“The total disappearance of the Scandinavian colonies on Terre Verte in the fifteenth century had various causes. Norway lost interest in these faraway peoples and eventually banned all contact with them. English piracy made the northern seas unsafe, as evidenced by the sack of Eystribygð in Greenland in 1418. Above all, the climate changed abruptly. Huge icebergs moved southward, blocking the coastline and causing famine and disease. The fate of the Greenlanders remains a mystery. Expeditions sent by the kings of Denmark over the following centuries to re-establish contact with them showed that there were only a few groups of Eskimos left on the island. It is highly unlikely, however, that the cruelest of epidemics could have completely destroyed such a large population. It is far more likely that the Greenlanders emigrated to more hospitable lands. But they never returned to Europe.”²¹

The Viking colonization of Greenland began in 986 with the settlement of the exiled Erik the Red, who gave it its current name: “Green Land”; and subsequently continued by his family. “For four centuries,” says *Frédéric Durand*, “the descendants of these pioneers lived in southwestern Greenland, raising livestock, fishing, and hunting. Moving from fjord to fjord, they formed two settlements, that of the West and that of the East, by far the most prosperous. The latter counted up to 190

21. *Le grand voyage du Dieu-Soleil*, Jacques de Mahieu, 1971; pp. 24–25.

farms, 12 churches, and 2 convents. In 1124, a bishopric was created in Garðar, a commercial center that knew an opulence hardly imaginable at the foot of its glaciers; a cathedral was erected there — the largest in the North — hardly smaller than that of Trondheim and flanked by administrative buildings and warehouses. In the face of a deadly hostile nature, literature even flourished as proven by two of the *Edda* poems conceived in Greenland, the *Atlakviða* and the *Atlamál*, thus affirming to posterity the extraordinary vitality of the Viking race.”²²

Before drawing conclusions, it is worth taking into account the intense activity of the Catholic Church. In this regard, Jacques de Mahieu emphasizes that “the Church played an important role in the colonization of Greenland. The first Christian missionary, brought from Norway by Leif Erikson, arrived in the year 999. At first, resistance to the traditional faith was considerable, and remained so for a hundred years. But Catholicism rapidly asserted itself during the eleventh century. Churches, convents, and schools sprang up everywhere. In 1121, Rome gave the island its first bishop, and sixteen more followed. There is still mention of a bishop of Gardar in 1409, but there is good reason to believe that this episcopal see was abandoned by its incumbent in 1342, when, according to a Latin manuscript written by Gissle Oddson,²³ bishop of Skálholt, in the eighteenth century, based on the town’s archives, the Greenland population abandoned Christianity.”²⁴

Here is the mystery: a population that changes *religion and disappears*. And we can add: a “Nordic” population, i.e., of pure

22. *Les Vikings*, Frédéric Durand, 1965; p. 29. “Pendant quatre siècles, les descendants de ces pionniers vivront dans le sud-ouest groenlandais d’élevage, de pêche et de chasse. Essaimant de fjord en fjord, ils constituent deux colonies, celle de l’Ouest et celle de l’Est, de loin la plus prospère. Celle-ci compté jusqu’à 190 fermes, 12 églises et 2 couvents. En 1124 un évêché fut créé à Garðar, centre commercial qui connut une opulence difficilement imaginable au pied de ses glaciers ; une cathédrale y fut érigée, à peine plus petite que celle de Trondhjem — la plus grande du Nord — et flanquée de bâtiments administratifs et d’entrepôts. En face d’une nature mortellement hostile, la littérature a même fleurir comme le prouvent deux de poèmes des *Eddas* conçus en Groenland, le *Atlakviða* et le *Atlamál*, affirmant ainsi aux yeux de la postérité l’extraordinaire vitalité de la race de Vikings.”

23. Gíslí Oddsson, 1593–1638, author of *De mirabilibus Islandiæ*, finished two months before his death.

24. *Op. cit.*, Jacques de Mahieu, 1971; p. 24.

Hyperborean blood. The ease with which the most absurd hypotheses are usually accepted when adequate explanations are lacking is remarkable. The current theories about Greenland, which affirm that said land had a “mild” climate in the thirteenth century, suitable for supporting a large population, and that it became “hostile” a century later, provoking the emigration (to where?) of all the inhabitants, must be qualified in no other way. On the other hand, John Dee was proposing a different interpretation in order to solve the enigma. According to the sage, the Catholic Church knew very well that the Vikings had gone “to another world” in the fourteenth century after a change of religion, which is why they kept the secret.

Apart from all the fantastic stories that were known since the Middle Ages, for example the voyages of the Zeno brothers, those of Saint Brendan, or the more certain Viking legends that we have mentioned, two recent events had occurred in relation to Greenland that John Dee highlighted in *fourth place* of importance to Queen Elizabeth I. One: the “secret” voyage of the Jewish admiral Christopher Columbus to Greenland in 1476. Two: the voyage of the Icelandic Sigurður Stefánsson in 1570.

With respect to point “one,” the voyage of Christopher Columbus, it is worth recalling that History admits four voyages of the Admiral to the New World. “In fact, the admiral made five voyages,” says *Pierre Carnac*, “and it is precisely the first of these that is overlooked. Indeed, before sailing to the Lucayas in 1492, Columbus had almost reached Greenland, following in the traces of the Zeno brothers.”²⁵

However, for Jacques de Mahieu, Columbus did indeed reach Greenlandic territory on said voyage:

“But the most important voyage for us is that which he [Columbus] made to Thule. We only know it from a paragraph of a letter from the Admiral that Ferdinand and Las Casas quote: ‘In the year of 1477, by February, I sailed beyond Tyle one hundred leagues, the southern part of which is distant from the equinox 73 degrees, and not 63 as some wish, and lies not within the line that includes the Ptolemaic West, but is much more westerly; and the English, principally those of Bristol, go with their merchandise to this island, which is as large as England; when I went there the sea was not frozen,

25. *L'histoire commence à Bimini*, Pierre Carnac, 1973; p. 348.

although the tides were so heavy that they rose twice a day 26 fathoms and went down as much.’”²⁶

By what motive would Columbus have undertaken a perilous voyage to Thule (i.e., Greenland)? And what is more puzzling: how could he do so if he was lacking the means to put together a ship and mount a costly expedition? Jacques de Mahieu also provides a possible answer to this last question; as for the first question, on the motives that impelled Columbus toward Greenland, the answer will be made evident a few paragraphs ahead:

“Portuguese ships were not frequenting the ports of Scandinavia,” says Jacques de Mahieu. “Had Columbus managed to go to England and embark there for Thule? But under what title? Perhaps the key to the enigma lies in an expedition mounted in 1476 by King Christian III of Denmark with the purpose of finding traces of the Norwegian colonies in Greenland, of which there had been no news for a long time. Strangely enough, at first sight, Christian III had requested and obtained the help of King Afonso V of Portugal for his enterprise. The ships were Danish, and their commanders, Admirals Pining and Pothorst, were German. Under these conditions, what could the support given by Alfonso consist of? Lisbon was famous at the time for its navigators, men capable of reading and designing maritime maps and of guiding ships by the stars. However, the expedition had a navigator named John Scolvus, of whom no one will ever hear of again. The Danish ships did not rediscover the lost colonies, but they reached Labrador, if we trust a map from 1582, due to one Michael Lok, in which a land that bears the name of Scolvus Groetland appears to the west of Greenland.”²⁷

The mysterious John Scolvus²⁸ of the preceding quotation is none other than Christopher Columbus who, as has been proved, was of Jewish race and seeming to master the Numerical Kabbalah.²⁹

26. *La geografía secreta de América antes de Colón*, Jacques de Mahieu, 1971; p. 80

27. *Op. cit.*, Jacques de Mahieu, 1971; pp. 83–84.

28. The surname “Columbus” was spelled in different epochs and countries as follows: Scolnus, Scolvus, Scolvo, Kolonus, Scolom, Skolum, Colum, Colom, Colón.

29. There are two Kabbalahs: the Numerical Kabbalah and the Acoustic Kabbalah. An exposition on the origin and significance of both sciences is found elsewhere in this narrative.

On the Jewish filiation of Christopher Columbus, the arguments that Pierre Carnac, the already quoted author, provides can be considered, among many other sources, in a paragraph that we transcribe next. In it, the French author mentions the Entailed Estate drawn up by Columbus in 1498 where the latter refers to his signature:

“However, some of the admiral’s writings and notes in the margins of his readings give us a clearer picture. The most important is the Mayorazgo [entailed estate] of 1498, in which Columbus explains his signature: ‘Don Diego my son, or any other who may inherit this entailed estate, sign my signature, which I am now accustomed to, which is an X with an S above it, and an M with a Roman A and an S above it, and then a Greek Y with an S above it, with the lines and points, as I now do; and he shall write only *Admiral*, even if the King gives him or he gains other titles...’³⁰

“The Christian historians of the Admiral have very incorrectly transcribed the position of these letters and added some things. The purpose of this falsification was to establish that the abbreviations meant:

· S ·	Señor
· S · A · S ·	Su Alta Señoría
X M Y	Excelente, Magnífico e Ilustre

“The alignment that we have just reproduced was that of honorary titles in documents of the time, and in no way accounts for either the triangular figuration found in the Mayorazgo, or its text (an M surmounted by a Roman A and above that an S for the middle vertical line).”³¹

What would then be the *true* meaning of such an enigmatic signature?

30. “Don Diego, mi hijo, ó cualquier otro que heredare este Mayorazgo, despues de haber heredado y estado en posesion de ello, firme de mi firma, la cual agora acostumbro, que es una X con una S encima, y una M con una A romana encima, y encima della una S con sus rayas y vírgulas, como yo agora fago, y se parecerá por mis firmas, de las cuales se hallarán muchas, y por esta parecerá. Y no escribirá sino *el Almirante* puesto que otros titulos el Rey le diese ó ganase: esto se entiende en la firma y no en su dictado que podrá escribir todos sus titulos como le pluguiere; solamente en la firma escribirá *el Almirante*.” (Institución del Mayorazgo, 22 de febrero de 1498.)

31. A good study of the question is that of “Who Was Columbus?” published by Dr. Cecil Roth, Reader in Hebraic Studies of the University of Oxford, in the *Menorah Journal*, Vol. XVIII, October–December 1940.

“In reality, there can be no doubt,” responds Pierre Carnac. “In the Admiral’s arrangement, these letters represent *the Star of David*, and in their meaning, as Maurice David³² has shown, they constitute a *Kaddish*, a beneficial inscription that the unknown Columbus may have used to ease his ‘converso’ remorse. Jewish history professor J. R. Marcus proposes the following text for this Kaddish:

Shadaï	שדי
Shadaï — Adonoi — Shadaï	שדי — אדני — שדי
Yahwh — Male — Chesed	מלא — חסד — יהוה

“which is a warlike invocation to the one holy God, the God of hosts of the Old Testament.

“Just as in his calculations on the age of the world, Columbus relied solely on ancient Jewish tradition, he never failed to trace on each page of the letters that he sent to his son, and *always in the same place*, a monogram formed by the intertwining of the Hebrew letters Beth and He, which is none other than the *Baruch Hashem*, the ancient Jewish formula of greeting and blessing. It is worth noting that the admiral only used it in letters of a confidential nature.”³³

Christopher Columbus, Jew, Kabbalist, and inspired traveler. What was he looking for on his voyages, made at a time when a terrible repression was punishing his brothers of race in Spain, Portugal, France, etc., and with Palestine in the hands of the Arabs? Simon *Wiesenthal*, the sinister Austrian Nazi hunter, does not hesitate in affirming that Columbus was “a prophet,” commissioned by Jehovah to find a new Promised Land for the Hebrew people. On the other hand, Columbus himself confesses it repeatedly: he has a *mission* to fulfill; he has been guided by Jehovah in order to search for *Eden*, the *Earthly Paradise*, which in the Middle Ages used to be identified with Thule, Elysium, the Fortunate Isles or many other mythical islands.

“We must therefore be convinced,” adds P. Carnac, “that what he [Columbus] was aiming for was not so much the fabulous India that haunted the dreams of the time, as the *Earthly*

32. *Who was “Columbus”? His Real Name and Real Fatherland; a Sensational Discovery Among the Archives of Spain (with Photostatic Reproductions of Forty Letters Written by the Discoverer of the Americas)*, Maurice David, 1933; p. 103

33. *Op. cit.*, Pierre Carnac, 1973; pp. 345–347.

Paradise itself, the land of the blessed of which the old legends still speak.

“The proof? you may ask. Let us first listen to the admiral and follow him in the genesis of his inspiration, since his relationship with paradise preceded the voyage of 1492 and was to outlive it. The first traces that we find are his annotations in the margin of Cardinal [Pierre] d’Ailly’s (Petrus Aliacensis) *Imago Mundi*,³⁴ an incunabulum printed in Louvain between 1480 and 1483. Next to the passage in which D’Ailly describes what the ideal land must have been like, pointing out that ‘it is probable that the terrestrial paradise was a region of this kind, and this must also be the case of this place which the authors call the Fortunate Isles,’ we read in the admiral’s own handwriting: ‘The earthly paradise is certainly the place which the ancients call the Fortunate Isles.’ And further on, when the cardinal shows that there can be no identification between these islands and Eden, it is with regret that Columbus notes: ‘Error of the gentiles who affirmed that the Fortunate Isles were paradise because of their fertility.’”^{35 36}

We believe that it is not worthwhile to add more. The above is enough to make it clear that Columbus was secretly seeking *the door to Paradise*, that is, the *door of Chang Shambhala*, since

34. “Students of medieval geography in general and of the Columbus problem in particular are very much indebted to Edmond Buron for a critical edition of the *Imago Mundi*. On the left hand page M. Buron has printed the Latin text and facing the Latin text he has provided a French translation. This is a valuable aid to students, even to those equipped with a moderate knowledge of Latin, because the Latin text is filled with obscure abbreviations the sense of which it is often difficult to determine. In the margins of each version, Latin and French, M. Buron has placed the marginal notes of Columbus and his circle in proper relation to the corresponding text. In copious footnotes M. Buron has added the corresponding text of the various ancient and medieval works on geography. In this way he has endeavored to show the source of the material D’Ailly placed in the *Imago Mundi*. This alone was a most exacting work. Then, foreseeing that other scholars might not agree with his interpretations of the obscure and abbreviated Latin, M. Buron assisted in the production of a facsimile edition of the Colombina Library copy of the *Imago Mundi*. This facsimile was issued by the Massachusetts Historical Society in 1927. M. Buron’s work is distinctly the most valuable contribution to the study of the Columbus problem which has appeared since the works of Henry Vignaud. The full title of M. Buron’s edition is *Ymago Mundi de Pierre d’Ailly, cardinal de Cambrai et chancelier de l’Université de Paris, 1350–1420* (Paris, 1930). The generally accepted form of the title is “*Imago Mundi*.” (“The *Imago Mundi* and Columbus,” George E. Nunn, *The American Historical Review*, Vol. 40, No. 4 [Jul., 1935], pp. 646–661.)

35. “Error de los gentiles que creían que el paraíso era esta islas por la fecundidad del suelo.”

36. *Op. cit.*, Pierre Carnac, 1973; p. 348.

the Jews correctly identify the lair of the Demons with the Eden of Jehovah. Under this optic, Columbus appears as what he really was: an envoy of the infernal powers with a specific *mission*. We will speak later about the nature of this *mission*, which had the objective of neutralizing the action of the Gral, secretly brought to South America by the Norman Cathars, and *to close the door* to the North. On this last point, remember that the Danes of the expedition of Scolvus (or Columbus) in the year 1476 found no one in Greenland. *But from then on the door was closed again*. It is a great Hebrew magician, perhaps as great as Solomon, who has come to the frozen lands of the North to *fulfill the ritual*, to *pronounce the words*, to *perform the gestures*. It was necessary that it be so, for the door *was forced open* by a brave Viking peoples, of the purest Hyperborean blood, against whom the magic of the Druids can do nothing. For it has always been so: the Druids have easily dominated the Celts, Iberians, Ligurians, Basques, Semites, Phoenicians, and Carthaginians, and even the Latins; but, in the case of Germanic peoples, it is necessary that the greatest masters of the infernal arts deal with them. And that is why, to the extent that the Germanic peoples *advance toward the West*, i.e., *consciously penetrate into the Kaly Yuga*, it will be the most sinister Hebrews who will conspire in order to plunge them into *strategic confusion*.

Dr. John Dee was warning Queen Elizabeth I about this *first* voyage of Columbus to Thule, which had occurred a hundred years earlier. And he was also calling attention to the voyage of *Sigurður Stefánsson*, during which he drew a highly suggestive map that had recently arrived in England. Said map presents a shield with the name of the author: *Sigurdi Stephanii*; the territory drawn: *terrarum hyperborearum*, and the date of the drawing: *delineatio Año 1570*.

Clearly seen on it: to the south, the two islands of Irland (Ireland) and Britannia (England) and to the north, Greenland. But the most interesting for John Dee were the annotations made to the north of Greenland. There, marked with a C, it says: *Riseland*, "*They call it the Region of Giants, because there are horned giants, who are called Skriekfiña.*" Marked with an E, it clearly reads: *Iotun-heimar*, "*Jötunheimar is the same as the realm of monstrous Giants; it can be supposed that the kingdom of Geir-röðr and Guðmundr was here.*"



Sigurður Stefánsson's Map

II. Development of the Thule Project

Summarizing all the indications, warnings, and advice given by Dr. John Dee to Queen Elizabeth I of England, the Thule Project could be described in terms of the *objectives* to fulfill and the necessary or available *means*. This strategic analysis would then enable us to arrive at alternative tactical variants.

Objectives:

1. To endow England with maritime and terrestrial supremacy over all the known world and also over *the unknown worlds*.
2. To assure to Elizabeth I or to those who succeed them, the nobles whom she designates or to those who succeed them, the erection of a vast universal empire such as has never been seen before and before which those of Alexander, Caesar, Genghis Khan, or Charlemagne would be dwarfed.
3. To achieve, at the time of such objectives, that “the grace of the Holy Spirit” *transforms* the peoples of the Anglo-Saxon Empire for the greater glory of *Christus Lux*.

Means: the means for concretizing such objectives consist in strictly following an appropriate plan, that is to say, a “Hyperborean Strategy.” In order to fulfill such a Strategy, which is the key to the Thule Project, Dr. John Dee established five indispensable steps:

1st Step - The immediate strategic occupation of Greenland by English troops, ensuring, in this way, the Empire’s exclusive control of the *entrance to the other worlds*.

2nd Step - To select and train an elite of knights initiated into the magisterium of the “Great Work” and into the secrets of the *spiritual struggle*.

3rd Step - To search for a “stone from heaven,” properly carved and “tuned” in order to “open the doors” that permit accessing the other worlds.

4th Step - To summon all *sensitive* persons in the Kingdom who can collaborate in order to find the exact location of the doors. According to John Dee, this can also be exactly determined by means of mathematical calculations for which one would have to initiate the corresponding studies.

5th Step - To develop new weapons and perfect the existing ones based on gunpowder, resorting to Alchemy and Magic if necessary.

A study of the feasibility of applying the preceding Strategy yields two alternative tactics.

1^o Tactic: if the *totality* of the steps are managed to be fulfilled, *invading* the world of the giants can proceed, initiating its conquest. After subduing the demonic beings, the Kingdom must *make use of them* in order to establish the Universal Empire.

2^o Tactic: if all the steps cannot be fulfilled, it is necessary to give priority to the 4th Step in order to *besiege the door*, while the 2nd and 5th Steps are reached. In this way, guarantees are obtained that allow to face the war of conquest with some certainty of triumph. The 3rd Step can be omitted on the condition of precisely establishing *the astrological moment* in which the door opens by itself once a year. With this alternative, even if it takes more time, the conquest of the “other worlds” can be conveniently prepared.

In either of the two alternative tactics, the key to obtaining success is the *1st Step*, of which it is not possible to do without,

since the occupation of Greenland *ensures* that sooner or later the threshold can be forced open.

III. *Synarchic Reaction Against John Dee*

As we already said, the communications that John Dee made to Queen Elizabeth I were soon known by the Welsh Druids, who were infecting the Kingdom, and promptly forwarded to Chang Shambhala. There the news that an awakened Virya was in possession of an Atlantean transducer through which he was in contact with the Hyperborean Siddhas caused a *special reaction*. But the most impressioning thing for them was finding that the Thule Project consisted of an almost exact copy of the plan of Nimrod, whom no one could ever forget in the demonic ranks. That is why the Synarchy decided to act immediately and definitively liquidate Dr. John Dee.

Neutralizing John Dee thus became the Demons' priority objective, and to that end they sent two "disciples" to London: a Jew named *Barnabas Saul* and a fearsome Druid by the name of *Edward Talbot*, later known by his Celtic pseudonym of *Kelley* or *Kelly*.

The first approached John Dee's intimacy preceded by a certain "fame" as a clairvoyant, which some "trusted" persons took care to emphasize. But his excessive interest in the talking stone and the falsity of some "communications" that he was claiming to have obtained by contemplating it, led this relationship to a crisis that culminated in the early dismissal of the Hebrew spy. We will not dwell on this miserable figure. Instead we must pay special attention to Kelley, for he represents the prototype of the Druid infiltrated into a determinate circle with the mission of destroying it and was, in fact, the executing arm that led John Dee to ruin. Ruin from which, however, would emerge, with unequaled strength, a Hyperborean Secret Society in charge of preserving the *Steganographia* of Trithemius, the Thule Project, and the manuscripts in the Enochian language.

Unlike the insignificant Barnabas Saul, Kelley was quite a character. About him Figuier wrote:

"Toward the end of the sixteenth century, a time when lawyers were already quite notorious in England, there was a notary in Lancaster, others say in London, who was despised by all for the productive industries that he attached to the

deeds of his department. Talbot was his name. Born in *Worcester* in 1555, he had applied himself in his youth to the study of the old English language, and had become highly skilled at it. No one was more adept than he at deciphering old titles and resurrecting, for the benefit of his clients, rights buried in the dust of registries. Not only could he read all kinds of ancient writing, but he also excelled at imitating it. This latter talent exposed him to dangerous solicitations that, to his misfortune, he did not always know how to resist. Too well rewarded, his zeal knew no bounds; Talbot came to falsify titles, and even to fabricate them in the interests of his clients. Prosecuted for these acts, and convicted of forgery, he was banished from the city. The magistrates, wishing to teach a lesson to all his colleagues, even ordered that both his ears be cut off, and this order was carried out."³⁷

The information that Figuier exposes, compiled in the nineteenth century, is quite accurate; but it gives a puerile explanation for Kelley's lack of ears. For throughout history abound examples of "esoteric" persons who were exhibiting mutilations of various kinds (fingers, ears, sexual organs, etc.), which must be considered as "ritual mutilations," the product of the infamous blood pacts that such "adepts" make with the infernal potencies that lurk behind the Synarchy.

Talbot-Kelley was secretly dedicated to stealing any ancient document that came into his hands. In the Hospitaller Country of Wales, many Templars who were fleeing from the European Inquisition in the fourteenth century had taken refuge, in the same way that the Cathars had done in the thirteenth century and numerous alchemists for several centuries. All had taken with them that which they were considering most valuable for the teaching of the occult arts; and it was a well-known fact in Kelley's time that Scottish castles were keeping veritable treasures in forgotten and dusty chests. His profession was permitting him to have access to these materials, which were quickly stolen or replaced by skillful forgeries in which the most dangerous secrets were expurgated. The task of secret agents like Kelley is undoubtedly why so many absurd and incomprehensible manuscripts from the Middle Ages exist today.

37. *Alchimie et les alchimistes*, Louis Figuier, 1854; pp. 197–198.

As Dr. John Dee was the most prestigious specialist in cryptography and philology in England and was cultivating a penchant for collecting ancient manuscripts of alchemy or occultism, he was bound to stumble upon Kelley during his searches. This had occurred some ten years earlier and since then the astute Kelley had maintained a friendly relationship with John Dee, stimulated by the sale of manuscripts and books to which the sage was so addicted and that the Druid was obtaining with surprising ease.

At the beginning of the reign of Elizabeth I, a devastating attack was unleashed against the Catholic Church and its followers that encompassed the whole of Great Britain. In these actions, numerous convents and abbeys were sacked and castles, estates, and other possessions of the Catholic nobility were expropriated. It is understandable that in these circumstances a character like Kelley had to take advantage of every opportunity that presented itself in order to get his hands on the books and writings of the Protestant plunder. Consequently, after 24 years of Elizabeth I's reign, the assortment of materials in Kelley's possession was endless. But the most important thing consisted in the fact that he always knew where to find the rarest documents in order to satisfy John Dee's wishes. He was enjoying the confidence of the latter, when in 1582 he appeared in London, extremely interested in observing the famous talking stone.

The strategy that the Synarchy applied in order to neutralize John Dee can be summarized in two tactical blows:

1º) To intrigue the court in order to discredit the sage and isolate him from Elizabeth I, his protectress. As the sage was lacking in personal resources, the success of this tactic would mean his economic ruin, it is to be expected that the Thule project would become impracticable after the fall of its mentor.

2º) The "adept" Kelley should keep himself as close as possible to John Dee, "accompanying" him in his misfortunes and awaiting the opportunity to deliver the coup de grâce. The objective of this action would be: a) to obtain the magic mirror in order to be "returned" to Chang Shambhala; b) to "recover the dangerous material" that John Dee had in his possession, namely *Steganographia*, the writings in the Enochian language, and the irreplaceable library of manuscripts and incunabula;

c) to assassinate the imprudent Dr. John Dee when the disrepute would have plunged him into ostracism and obscurity.

In order to fulfill the preceding strategy, the natural naïveté of the sage was exploited first. In effect, in 1582 Kelley presented himself with a bag containing a yellowish powder, of which he was claiming that it was a “Philosopher’s Stone.” He recounted the story that it had been found in a Welsh Catholic bishop’s tomb, which was desecrated in the days of the Protestant revolt. Along with the powder was found a manuscript that was teaching the *Ars Regia*, the artificial manufacture of gold by means of alchemist operations. The document was in cipher, as was customary in those times, and according to Kelley, only an expert like John Dee could decipher it. Incredible as it may seem, this simple ruse paid off and the sage soon found himself enthused about successfully performing a transmutation.

The English sage easily deciphered the manuscript and followed its instructions. Thus it was how, with the assistance of the yellow powder *provided* by Kelley, he soon obtained a few pounds of gold in the crucible. But that powder, that “Philosopher’s Stone,” was in all likelihood an auriferous compound prepared by the astute Druid for purposes of deception, which explains the fantastic transmutation. We say this not because we deny the possibility of alchemical transmutation, but on the contrary, because *the true Philosopher’s Stone functions in resonance with the vital fluids of the magister*, like all techniques of the same type, and could not be utilized in the form that Kelley did in order to deceive John Dee. The most certain thing is that gold *was present* in the yellow powder.

Be that as it may, the fact remains that Kelley suggested communicating the discovery to the court, sinister advice that, upon being foolishly followed by the sage, signaled the first success of the synarchic tactic. For as soon as the fact that the sage could “make gold” was made public, several influential persons began to intrigue with Elizabeth I so that she would suspend all the salaries that the crown was paying to John Dee. This measure would not have affected our hero were it not for the fact that, predictably, the yellow powder did not produce more gold... The subsequent retractions and clarifications only served in order to cement his discredit and did not reverse the economic situation that was becoming more and

more critical, since he did not receive a penny more from the English crown.

Two years later he was in complete ruin, selling off some of the valuable manuscripts in his library in order to be able to eat. The “clients” interested in acquiring such works were introduced to the sage by Kelley! As can be seen, then, in 1584, the success of the synarchic strategy was total and surely the illustrious sage would have soon been assassinated, had it not been for an unforeseeable event for the demonic ranks. This saving event for John Dee has no *causal connection* with his misfortunes, but clearly presents evidence of a *charismatic bonding between Viryas*, which is *synchronistic* for the members of the *Catena Aurea*.

We must remember, from the “Stone Mirror” chapter, that the German Emperor Rudolf II was keeping a secret correspondence with Elizabeth I in order to negotiate the sale of Princess Papan’s magic mirror. This mirror is the same one with which Dr. John Dee was speaking to the “angels,” who dictated to him countless pieces of knowledge in the Enochian language. But in 1584, after the campaign launched against him, no one was believing in the properties of the mirror or in the spiritual powers of Dr. John Dee. That is why Elizabeth I, for whom the magic mirror was only a piece of ugly polished rock and the Thule Project an impossible utopia, decided to employ the unfortunate John Dee for something more imminent and concrete: the war against Spain; and so that he would deploy an activity in which he always excelled: espionage.

For the skillful sovereignty, obtaining information about Spain was of vital importance; and a suitable place for this was undoubtedly the Bohemian court of Rudolf II, nephew of the Spanish King Philip II. She decided to carry out this enterprise by advising Rudolf II that she “could not part with the precious American stone,” but that she would “gladly send it to Prague with a prestigious and wise messenger by the name of John Dee.” The maneuver had the object of infiltrating the spy into the German court in order to acquire all the information possible about the Spanish Habsburgs and, if possible, to get Rudolf II to provide him with a safe-conduct in order to reach Spain itself. As one can see, it was a suicidal mission, very different from those journeys to the Netherlands that he made in the past for acquiring compasses or Portuguese maps for the benefit of the English crown. But no alternatives were left to

John Dee. Beset by hunger, bewildered by the sudden “change of fortune,” his health undermined by the systematic poisoning to which Kelley was subjecting him with his drugs that the Druids know so well, and with his wife totally dominated by the former; in short, because of so many sudden misfortunes, the sage did not hesitate in accepting the enterprise.

Since Kelley came into John Dee’s life, his literary production practically ceased and even his power to “talk to angels” completely diminished. He was now needing to concentrate for a long time in order to achieve the “contact” and when he was obtaining it, *everything was happening with such a speed* that he was incapable of retaining the messages in the Enochian language. He was eventually forgetting the content of the message. That is why he used to lend the mirror to Kelley, who was never achieving visible results and was often lying, a fact that John Dee was immediately noticing even though he was opting to remain prudently silent. He was attributing Kelley’s maneuvers to a “wounded Alchemist’s pride,” who needs to lie in order to justify some success. And, we must say, he never suspected Kelley of evil or believed that he formed part of a conspiracy, except at the end of his life, when he was already irremediably lost. How can an awakened Virya make a mistake like that? We will explain this at the end of the *Fifth Book*, when dealing with the *synarchic fence*.

Before leaving for Europe with Kelley, who was not leaving the sage’s side, he gallingly consulted the mirror and obtained the advice to transport all the Enochian-language manuscripts and *Steganographia*. This suggestion made Dr. John Dee turn pale with terror, for being aware of what had happened with Trithemius, he was not thinking it prudent to take to Catholic Europe a book that was in the Congregation of the Holy Office’s *Index Librorum Prohibitorum*.

To be in possession of a forbidden text was still meaning the stake in 1584; and if, in addition, he was accompanying it with copious ciphered texts, his manuscripts would be judged no differently, since the Enochian language was totally unknown, the danger of arousing suspicion would be greater. However, it was the “good” Kelley who finally convinced him to take them. The interest was due to the fact that the Druid was confident that he would succeed in destroying the texts along the way or in denouncing John Dee when the slightest opportunity presented itself. And so it was that one day, armed with a trunk

SECOND DISSERTATION

fortified with steel bars, full of “heretical material,” John Dee, Kelley, and their respective wives, departed toward Holland where, on the border of Flanders, Rudolf II’s envoy was awaiting them in order to lead them on a long journey to Prague.

John Dee in Bohemia



he travelers met in the village of *Tilburg*, near the border with Flanders, with *Hieronymus Scottus*,³⁸ special envoy of Emperor Rudolf II. This mysterious personage, also known as *Scotto*, who was a diplomatic emissary and official exorcist of the Emperor, presented himself accompanied by an escort of thirty arquebusiers. From the outset he was loquacious; and during the long and fatiguing journey, he did not cease referring to subjects of magic and occultism, of which he spoke with considerable fluency, something unusual, John Dee marveled, in someone who was coming from a Catholic court.

Of course, the English sage had not yet arrived in Prague; and therefore could not suspect to what extent the court of Rudolf II had become the “Mecca” for the occultists and magicians of Europe.

The forthcoming presence of the English sage in Europe, despite having been concretized as a result of a secret negotiation, was known in advance and gave rise to a certain expectation among the numerous alchemists who were partaking of the royal favors. John Dee was arriving, preceded by a dubious notoriety as a magician and necromancer, which in reality was bearing little relation to his profession as a mathematician and optician; and he was expected to “perform great wonders” in his audience with the Emperor Rudolf II. Also, the existence of the magic mirror was publicly known by news from England; and the possibility of contemplating it, and even of “seeing” the “instructing angels” through it, was adding a double interest to its visit. In synthesis, a whole reception was prepared in Prague to celebrate the arrival of the sage. It was expected that he would give a lecture at the University, to which the most awakened intelligences of the Court would attend and, depending on the impact that it would cause among the attendees, many would be those who would offer to serve as disciples in the hope of gaining valuable revelations.

38. Hieronymus Scottus (a.k.a. Hieronimi Scotti, Girolamo Scoto, Jeronimo Scotto, etc.) was an Italian adventurer and alchemist, not to be confused with the composer and printer of the same name living in Venice from 1505–1572. See Footnote 4.

The magician Scotto was kindly communicating such news while they were undertaking the first part of the journey, which consisted of courses toward the southeast until reaching the Rhine, some one hundred and fifty kilometers away. And throughout the journey it would be this diplomatic envoy who would first attempt to elicit John Dee's secrets. To do so, he was trying to earn his trust by confiding valuable information about the public and private lives of a great many princes and lords, a subject on which he was seeming particularly well versed. It is necessary to situate oneself in the Middle Ages, in times at which every movement, every activity, and even life itself, would depend on the whim of some lord, in order to realize the incalculable value that it was meaning to have such whisperings at one's disposal. That is why John Dee was avidly assimilating these data, but he was not satisfying Scotto's expectation to the same extent, by reciprocating his good predisposition with esoteric revelations. At least, that was what the exorcist was thinking, although he was very careful not to show it.

He had followed an ancient trade route, which a week later was bringing them within sight of Cologne, heir city of that Colonia Claudia Ara Agrippinensium that the Romans named in honor of General Agrippa,³⁹ who was sent by Emperor Augustus in order to "pacify" the Germanic peoples. From there they would take the ancient Roman road that borders the Rhine and longitudinally crosses the "Rhineland," which was once marking the boundary between civilization and the world of the barbarians.

The instructions that Scotto had for obtaining maximum security on the journey, consisted in following a trajectory that includes the transit through vassal territories of the German Emperor, whose lords were in the best relations with the crown, and evading any breach of trust about the *true reason* for the presence of the travelers. This last condition was due to the interest that the crafting of gold had gained among the nobles in the fifteenth and sixteenth centuries and the fierce competition with which alchemists, or those who were claiming to be so, were sought after. It was not uncommon in those times for a short-of-money prince to kidnap an alchemist in the dungeons of his castle and subject him to torment in order

39. Marcus Vipsanius Agrippa

to force him to confess the secret of the Philosopher's Stone or to "produce" the golden metal. Scotto was trying to ward off this danger by resorting to secrecy, but, as we have already said, this was a useless precaution, since John Dee's fame was well known and the news had spread that the Emperor was expecting him.

In Cologne, the Elector Albert V of Bavaria was at the head, who was also a Catholic bishop and zealous fighter of the Counter-Reformation, a cause for which a recent war had been waged, in 1583, against Archbishop *Gebhard Truchsess von Waldburg* who had apostatized from the Catholic doctrine in order to become a Protestant. In those years were incubating the religious rivalries and bitterness that would come to light three decades later in the bloody Thirty Years' War. In any case, Rudolf II, too occupied with investigating the mysteries of alchemy or with studying the gems that he had brought in from all over the world, was not actively participating in such religious struggles. Being the nephew of Philip II, the champion of the Counter-Reformation, and maintaining himself within the Catholic orthodoxy, no one was remembering that his father, Emperor Maximilian II, had died without receiving his last rites due to his intimate Protestant convictions. But the truth was that Rudolf II was acting with apparent indifference toward religious strife as a security measure, knowing that he was surrounded by the Pope's spies and that the only way to pursue his esoteric investigations without being disturbed would be to stay within the Counter-Reformation. This attitude of Rudolf II, although not awakening any sympathy in the ecclesiastical ranks, was not openly censured either; and there was no reason why his guests' presence in Cologne should not be welcomed by Bishop Albert of Bavaria. In any case, no imprudence was to come from John Dee; for he spent those days fascinated by the Gothic cathedral of Cologne, that magnificent display of *Druidic-Benedictine technology*.

After spending a few days in Cologne, our travelers departed, without problems, along the ancient path that the Roman legions followed, in the inverse direction, fifteen hundred years before when they were attempting to fulfill the dream of Emperor Augustus "to confine the barbarians beyond the Elbe." On that occasion three Roman legions, 20,000 men, under the command of Publius Quinctilius Varus, were annihilated by Germanic troops under the command of Arminius,

a defeat that motivated Varus' suicide and the definitive retreat of the Romans to the headquarters of Mainz. And precisely in Mainz was he concluding the second part of the journey, since there they were already under the protection of William IV, Landgrave of Hesse-Kassel, a prince who was in the confidence of Rudolf II and was also his relative.

After staying a few days in Mainz, the city where Gutenberg had invented the movable-type printing press over a century before, and a few more days in the castle that the Lord of Hessen was in possession of in Frankfurt, our heroes set out in order to fulfill the third and last stage of the long journey. From Mainz, turning in a straight line toward the east and traveling some five hundred kilometers, is Prague. However, it was not possible to follow this route directly in the sixteenth century without being forced to make numerous detours through wilderness and forests, cross rivers, and climb mountains. But, considering that these lands of Hessen and Northern Bavaria were sufficiently safe, such was the path chosen by Scotto, who was preferring to ford a torrential river rather than run the risk of being attacked by a mistrustful prince. Therefore, they soon found themselves moving through Bavaria, which is a country of beautiful valleys and dense forests in the North, but which rises in altitude toward the south until reaching the Alps, that mountain range that marks the boundary between Austria and Styria, the lands of the Habsburgs, i.e., of the reigning dynasty.

Following the indicated road eastward, one arrives in Bohemia, a country made up of a central plateau irrigated by the Elbe, which is surrounded by a mountain range in all directions except to the west. To the north, are the Ore Mountains that border Saxony and also the Sudetes, forming a boundary with Polish Galicia. To the southwest, the *Böhmerwald* separates Bohemia from Austria; and to the southeast and east, the Moravian Highlands form a poor fence with the country of the Slovaks. To the west of the central Bohemian plateau, there is a wooded region called the Bohemian Forest that separates this land from Bavaria, and into which the travelers would have to cross.

Upon reaching the Bohemian Forest, one is in front of a gateway utilized since ancient times by the peoples of the East in order to enter Europe. In the fifth century came through there the *Marcomanni*, who, because they had stayed in the country of the Celtic Boii (*Bohemia* or *Boiohæmum*, meaning

"land of the Boii"), were called *Baiovarii*, who inhabited and gave their name to the land:

Baiuvarii = Bavierans.

But Bohemia was coveted since ancient times by Celts, Germanics, and Slavs, whose multiple tribes disputed, in harsh wars, the right to inhabit it. The *Celtic Boii* settled first, evicted from Transalpine Gaul by the invasion of the *Cimbri* in the second century AD, the same invasion that pushed the *Helvetii* toward Switzerland. After the *Cimbri* were annihilated by successive Roman campaigns, the Gauls abandoned Bohemia to the *Marcomanni*, who were belonging to the Germanic people of the *Suevi*. When the Roman Empire weakened, the *Marcomanni* successively attempted to leave Bohemia for the more pleasant lands of southern Germany. This attitude motivated, among others, the expedition of Emperor Marcus Aurelius in the second century AD, the powerful army of whom crossed Bohemia and reached Galicia without achieving its goal.

In the fifth century, as we already said, the *Marcomanni* passed through the Bohemian Forest and occupied Bavaria. But other peoples from the East were also claiming the disputed plateau. After the *Suevi*, who were a Germanic people divided into numerous tribes like the *Marcomanni*, the *Quadi*, the *Hermunduri*, the *Bavarian Franks*, the *Semnonnes*, etc., some groups of *Wends*, i.e., Slavs, were advancing, among which the *Czechs*, the *Slovaks*, and the *Poles* stood out. The *Czechs* managed to settle in Bohemia, who would henceforth share this privilege with the *Suevi*, later reunited under the common denomination of *Germans*. But a third people called *Magyars*, of Yellow Race and related to the *Huns*, would vainly attempt to occupy Bohemia and Moravia, ravaging both countries from Hungary, their base of attack. However, the *Magyars* would never achieve their goal and soon Bohemia would be a kingdom, the crown of which, after Charlemagne and especially during the Romano-Germanic Empire, the *Czechs* and the *Germans* would bitterly dispute.

In 1250 the Roman-German Emperor Frederick II *Hohenstaufen* died in the Italian Apulia, then the Kingdom of Sicily. Upon his death, and the prompt execution of his three surviving sons, the Hyperborean stirp of the *Staufens* was extinguished, the kingdom entering that period that historians denominate *Interregnum*: "kingdom between two kingdoms,"

characterized by the acephalia of power or the simultaneous election of two kings, one Guelph and the other Ghibelline, so weak that they mutually neutralized each other. Only in 1273, thanks to a fable, the “resurgence” of the institution of the seven electing princes, which in fact had never functioned before, was it agreed to appoint the Swabian Count Rudolf Habsburg as King of Germany. From this episode, we should remember two things. First: one of the seven electors was the King of Bohemia. Second: Count Rudolf of Swabia marks with his reign the rise of the House of Habsburg, a seigniorial family of very pure Hyperborean lineage, which had a tremendous influence on the thrones of Europe until the nineteenth century.

Clarification: The lineage of the Habsburgs only decayed when successive marriages with several plebeian women of Hebrew origin, but of succulent dowry, produced in the familial blood a terrible strategic confusion (loss of the Minne) with the disastrous consequences for the House of Austria that we all know. It is worth remembering, as a complement to the story that we are narrating, that the mother of Ferdinand the Catholic, the King of Spain who died in 1516, was the Jewess Juana Enríquez [whose great-grandmother on her paternal side was the Jewess Yonati “Paloma” bat Gedaliah]. The daughter of Ferdinand the Catholic, Joanna the Mad, married to Philip the Handsome, had two sons: Emperor Charles V and Ferdinand I; from the latter descends the branch of the German Habsburgs. Emperor Rudolf II, one of the principal protagonists of our story, was the grandson of Ferdinand I and, therefore, was carrying in his veins the Jewish blood of his ancestress Enríquez. As this contamination prevented Rudolf II from attaining the mutation (into a Divine Hyperborean Immortal), as will be seen later on, we have thought it useful to make the present clarification.

Rudolf Habsburg, after a war with King *Ottokar* II of Bohemia and his subsequent assassination, obtained Austria-Styria as spoils for the inheritance of his house, leaving Bohemia and Moravia in the hands of Wenceslaus II, Ottokar’s son. However, after the death of Rudolf in 1291, Henry VII, Count of Luxembourg, was elected King of Germany, who acquired Bohemia and Moravia for his House as an allodial property upon the extinction of the reigning dynasties.

The war that Rudolf Habsburg sustained with King Ottokar II of Bohemia was won by the Germans at the great battle of

Marchfeld on August 26, 1278. However, this victory, far from being beneficial, signaled a permanent separation between the Czech and German population. “The continuation,” writes *Johannes Haller*, “of the union with the neighboring German lands, which had existed under Ottokar, would have in all probability led in the course of time to the assimilation and merging of the German and Czech populations, similar to the way in which in the lands east of the Elbe, in Mecklenburg, Pomerania, Silesia, and Prussia, the Wendish and Prussian populations were gradually Germanized. The separation that Rudolf’s victory forced, interrupted this process, intensified the natural antipathy of the peoples, and contributed significantly to the fact that in the fifteenth century the Czech nationalism of the Hussites turned hostile to Germanism.”⁴⁰

It should be noted that during the reign of the House of Luxembourg (1308–1437), Bohemia was always given special attention. As an example, it is enough to recall that King Charles IV, grandson of Henry VII, founded, in 1348, the University of Prague, the first in Germany, and elevated his court to the highest level of medieval science and art.

Years later, the German King Sigismund, the last of the Luxembourgs, dies. His son-in-law, Albert II Habsburg, is elected in 1438, definitively returning this House to the German throne and henceforth retaining the crown of Bohemia, which a descendant known to us, the alchemist Emperor Rudolf II, will wear one hundred and fifty years later.

Soon the caravan led by Hieronymus Scotus crossed the Bohemian Forest and began to march along a well-kept path that was bordering numerous tilled fields and offering the surprise, when descending a hill or crossing a grove, of showing the sudden appearance of the most beautiful villages that John Dee had ever seen. They were unique for their neatness and perfect integration into the landscape that made them ap-

40. *Von den Staufern zu den Habsburgern: Auflösung des Reichs und Emporkommen der Landesstaaten (1250–1519)*, Johannes Haller, 1960; p. 21. “Die Fortdauer der Vereinigung mit den deutschen Nachbarländern, die unter Ottokar bestanden hatte, hätte aller Voraussicht nach im Lauf der Zeit zur Angleichung und Verschmelzung der deutschen und der tschechischen Bevölkerung geführt, ähnlich wie in den Ländern östlich der Elbe, in Mecklenburg, Pommern, Schlesien un Preußen die wendische und preußische Bevölkerung allmählich eingedeutscht worden ist. Die Trennung, die Rudolfs Sieg erzwang, unterbrach diesen Vorgang, verschärfte die natürliche Abneigung der Völker und trug wesentlich dazu bei daß im 15. Jahrhundert der tschechische Nationalismus des Hussitentums sich feindselig gegen das Deutschtum wandte.”

pear almost like natural phenomena. “The English villages, so distinct,” John Dee was thinking, “have been constructed with the deliberate purpose of unmistakably affirming their human quality; and that is why they are always seen as if cropped on the horizon. On the other hand, these fairy-tale villages are interwoven with nature, blended into the surrounding world in such a way that it is not possible, for the intelligence of the observer, to extract them from there without provoking an abnormal mutilation to the rest of the landscape.”

Without being able to distinguish the limits of some buildings that were blurred among gardens and foliage, and without managing to perceive that exaltation of the form over the background, which is the basis of differentiation, John Dee had the impression of having penetrated into a painted image, into a painting by *Bruegel*: “These Bohemian villages are similar to many pictures that the landscape painters of Holland and Flanders make by blurring the edges of things, so that when we walk through a cottage, when we reach the barn, around back, without knowing how, we are immersed in the mystery of some trees, some land, some skies or waters, which surround and absorb everything in perfect and monotone continuity.”

In another part of this work, we will see how the conjunction of telluric energy with certain particular characteristics of this *site* generates a psychological microclimate in its environment. Because a special “microclimate,” which surrounds some Bohemian villages, was responsible for John Dee’s curious perceptions. But not only the English scholar, but a great many “sensitive” persons have intuited for centuries that in Bohemia there is “greater ease” for the exercise of the occult sciences. And it is because of this conviction that a special class of men, whose number, in those last decades of the sixteenth century, had notably increased, have always been seen passing under its skies. They are those who were arriving in Bohemia seeking to consummate a transcendent and definitive experience: *alchemists* will try to obtain the “Magisterium” by crafting the Philosopher’s Stone; the mystics, inspired by *Gioacchino da Fiore* or *Meister Eckhart*, will attempt to experience the ecstasy of God, the *mystical union*; *rabbis*, by studying the *Sepher ha-Zohar* and the *Torah*, will try to interpret the Law of Jehovah or to create the Golem; *astrologers* will procure, by reading the sky and interpreting its mysteries, to foretell the

future; *sorcerers* will conjure up spirits and demons in order to make unconfessable pacts with them; *craftsmen* will work to gain mastery in their guild: goldsmithing, sculpture, and painting are the main guilds; etc., etc.

All these men—many of whom are undoubtedly phonies and charlatans, but others surely are serious and even dangerous persons—have chosen Bohemia in order to carry out their most important experiment and, in particular, they are heading directly to Prague, the millenary city. Why Prague? John Dee, who was accompanying the caravan led by the magician Scotto and was already in sight of Prague, discovered it at once. The central Bohemian plateau is irrigated by the Elbe, that river that flows through Germany and empties into the North Sea in distant Holstein, that is, in former Frisia. The marly land of the plateau is drained by the Elbe and its tributaries: the *Ohře*, the *Berounka*, the *Vltava*, etc. And Prague sits on the banks of the *Vltava*, a tributary of the Elbe, the waters of which, originating in the Giant Mountains, carry strong currents of telluric energy. But that is not all. Prague is built on a powerful vortex of telluric energy of particular qualities, something of which we insinuated when studying the history of Nimrod. We will deal with this subject more extensively in another part of this narration. For now let us just say that the *vortex* itself represents a *bridge* between the concrete world and the subtler planes of existence; more technically, it can be said that the presence of the *vortex* “*weakens the barrier of plane interaction,*” endowing the site with vibrations suitable for *channeling* telluric and astral energies and practicing all kinds of thaumaturgy.

These properties that Prague possesses are, evidently, those responsible for the attraction that it has always exerted on the lovers of mystery. And it is now, in 1585, when the number of such visitors is greater than ever. The explanation of this sudden interest in Prague must be sought in the fact that, the city being the imperial capital, and at its head a tolerant and wise king like Rudolf II, himself a self-confessed “magister of Alchemy,” the advantages for the strange visitors are many. It is possible, for example, that someone succeeds in demonstrating “mastery” or the “magisterium” by performing a demonstration of his art to the Emperor who, if such a proof is positive, will not hesitate to richly reward the talent exhibited. Apart from the fantastic possibility of *safely* practicing arts

that all over the world are officially considered demonic and punishable by burning at the stake, is the advantage of having a city that *truly possesses* a telluric center of power.

It is understandable then that such advantages attracted an enormous number of persons who were populating the “street of alchemists,” the “Jewish quarter,” the “guild corporations” and some castles and counties ceded by the generous Emperor so that certain high-level scholars could pursue their studies. This was the case of the astronomer *Tycho Brahe*, who was able to set up an observatory in *Uraniborg*, making use of *Benátky nad Jizerou* Castle, where came to reside in 1600 Johannes Kepler, the great astronomer, discoverer of the laws that govern the movement of the planets around the Sun. But persons less rigorous than Brahe and Kepler were also surrounding Rudolf II. Two hundred alchemists were on the Emperor’s payroll, not counting another five hundred who were awaiting, among retorts, flasks, and crucibles, the opportunity to achieve a sufficiently showy result as to be worthy of a royal subsidy.

Jewish sages were also admitted into the Emperor’s court, mainly through his physician, *Tadeáš Hájek*, a native of Prague, who called himself *Hagecius*. This sinister personage brought the Emperor closer to the Jew *David Gans*, famous author of a history of the Talmud, and also arranged several interviews with the high rabbi, *Judah Loew ben Bezalel of Prague*. The latter personage, *J. Loew*, gained an unwavering celebrity for being the first Jew who gave life to the *Golem*, the indestructible robot constructed with clay and animated by means of kabbalistic formulas that allow one to insufflate into it the “*Breath of Jehovah Satan*.” The monster was controlled by writing on its forehead the Hebrew word *emét* (אמת, truth), which did not affect its vital functions, but if the “E” were erased, it remained *mét* (מת), which means “death,” and the Golem was automatically destroyed. Rudolf II received Rabbi *Loew* many times and it is possible that he subsidized him in secret as was his custom.

We will avoid detailing the innumerable quantity of curious personalities who made up the Emperor’s court—we will not speak, for example, of the powerful corporation of craftsmen, of the experts in precious gems, etc.—and will only name *Georg Popel von Lobkowitz*, representative of the Pope; the ministers *Wolf Rumpf* and *Paul Sixtus von Trautson*; the Jewish

banker and royal adviser *Jacob Bassevi*; for they all have a special part to play in this story.

This was, then, the imperial Prague that was receiving John Dee as one of the most important scholars of the century. A city invaded by strange personages who liked transiting along the edge of the abyss, but with a prestigious University that was among the first in Europe, in spite of the desertion of the German professors who left for *Leipzig* one hundred and seventy years earlier. On that occasion, the Czech John Huss, a former professor, inspired by the mystical current of the English *John Wycliffe*—a disciple of the Hyperborean *Gioacchino da Fiore*—attacked the corruption of the Church and publicly called on Christians to return to primitive Christianity. He was excommunicated in 1412 but the Czech people appointed him rector of the University and from his pulpit affirmed the supremacy of the *living Cosmic Christ* over the fossilized authority of the Pope. This imprudent stance that John Huss adopted prompted *three Crusades* of the Catholic Church—as 200 years earlier in the Cathar Languedoc—to arrive in Bohemia in order to suppress the Hussite heresy. Although the crusades could not obtain any victory by arms—let us say in truth that they suffered great defeats—they managed to get hold of John Huss by means of a deception, which consisted in assuring him immunity in order to agree on a truce. When John Huss presented himself before King Sigismund at the Council of Constance, the latter seized him and he was soon burned at the stake, still armed with his royal safe-conduct. From then on John Huss was transformed into a Czech national hero and his doctrine, principally expressed in his book *Tractatus de Ecclesia*, lasted until the following century, the sixteenth, in which he joined the religious struggles unleashed by *Luther* and *Calvin*. Throughout the sixteenth century, the struggles followed one after the other and fueled the bitterness that would erupt with singular violence in the Thirty Years' War.

When John Dee and the Druid Kelley arrived in distant Prague, they were sufficiently exhausted to intend anything other than to take an immediate rest. In order to comply with this necessary recuperation, Scotto arranged for both couples to be lodged in a Franciscan monastery that was operating in the castle of the former Dukes of Bohemia. Such a choice was not satisfying to John Dee, for whom the presence of the friars was producing a particular dread, since he was suspecting that

his hosts wished to know the contents of the armored trunk. But there was no possibility of modifying this arrangement, and soon the four of them were engaged in cleansing themselves and resting.

When Rudolf II learned of the presence of the Englishmen at his court, even though impatience was causing him palpitations, a malady of the Habsburg family, he decided to grant eight days of rest and attention to his guests before giving them an audience.

Those days flew by; and so it came to be that one afternoon the sage was led to the imperial palace for his formal presentation. During the days of rest, Kelley devoted himself to currying favor with Scotto, which he unconditionally achieved when he promised the latter to deliver him some of the "red dust." The exorcist was aspiring to obtain the magisterium of alchemy; and the astute Druid encouraged said expectation with the promise of supplying him the powder and teaching him how to make it. That is why, despite the resistance of John Dee who was counting on meeting alone with Rudolf II, Scotto announced that "the Emperor was expecting them both as Kelley's 'fame' as an alchemist and maker of gold had reached his court and he was keenly desirous of meeting him." Thus, along with John Dee, were also Kelley and Scotto when the Emperor made his entrance into the royal antechamber.

Accompanying Rudolf II was his dear friend, the nobleman *Wilhelm von Rosenberg*, a Bohemian of Germanic blood, and the ineffable *Hagecius*. After the courteous greetings of the time, Rudolf resolutely addressed John Dee:

"You must know, learned sir, that I have negotiated for years with your firm sovereignty in order to obtain the pleasure of this interview. I was already desperate for someone to come from England to show me so admirable a pagan trophy that cost the life of my nephew Frédéric de Bourgogne. But here I enjoy the twofold pleasure of receiving the trophy from the hands of a sage of your stature. I do not know what has changed the mind of Queen Elizabeth but, whatever it is, must surely be added to the permanent invocations to the Most High that I have been making for a long time in order to win her favor in this matter..."

Rudolf II was speaking without a hint of irony, getting impatient because John Dee was not immediately extending the mirror to him. At last, not wanting to press the mysterious

Englishman, he invited them all to visit a chamber known as the “Kunstkammer,” dedicated to containing the most complete collection of minerals, precious stones, and rare stones in Europe, that is, in the world. There were specimens of silver from Bohemia; gold and emeralds from America; diamonds and agates from Africa; topazes, turquoises, beautifully colored rock crystals, in short, precious stones from every part of the world, etc. It was the most vast exhibition of stones that anyone could imagine, gathered with infinite love by that alchemist Emperor whom no one in his epoch was able to intimately understand.

The keeper of the “Kunstkammer,” Daniel Fröschl, was explaining aloud the provenance and properties that were attributed to the various stones and minerals. He frequently consulted a book entitled *Gemmarum et Lapidum Historia* published in Prague by order of Rudolf II himself and written at his request by the royal physician *Anselmus Boetius de Boodt*.

“In the stones is enclosed a portion of the cosmic soul,” Hagecius was explaining aloud, “and by studying their properties, we will be able to understand the arcana of the Cosmos.”

The room was enormous, with vaults of wide gray stone arches supported by thick columns. It was furnished with cabinets and tables full of classified pieces and with a multitude of armored trunks with steel bars in which the most valuable objects were deposited. There was almost no place to walk on the floor because of the tubs and barrels destined to hold rocks and soils brought from remote places. Against one wall, a long and heavy table was supporting hundreds of flasks and vials with precious liquids of the most diverse origins. Naturally, this spectacle caused the astonishment of the travelers and that even a Druid like Kelley was momentarily distracted.

That was what happened when Kelley separated himself from the group accompanied by Hagecius, whom he was attempting to convince so that he show him the famous *Indian Stone*. This stone, apparently a *Bezoar*, is mentioned in the ancient medieval bestiary *Physiologus* as an infallible remedy for dropsy, a disease that was afflicting the Druid.

Taking advantage of this moment, John Dee took the Emperor aside and expressed to him the need to hold an interview alone, an unheard-of request coming from a foreigner without any rights in the German Empire, but perfectly justified in the case of dealing with diplomatic or esoteric matters.

And on this latter subject, Rudolf II was holding constant and reserved meetings with magicians and occultists from all over the world.

“We will meet tonight,” said the Emperor, “but my faithful *Wilhelm*, to whom I reserve nothing about things of the Spirit, will be present.”

Such a condition did not displease the English sage, for he had already perceived the “charismatic bond” that was uniting him with Burgrave Von Rosenberg in the mystery of the Pure Blood and *he knew that the latter was also an awakened Virya.*

The Hyperborean Initiation



hat night, the meeting between three of the most outstanding awakened Viryas of that epoch took place, a meeting that would be transcendental for the History and future of the West. John Dee handed Princess Papan's mirror to Rudolf II, who took it trembling with emotion, for he was mindful of the efforts made in the past for it to reach his hands. While the Emperor and Wilhelm von Rosenberg were examining it, John Dee was referring to his discoveries about the Enochian language without omitting the fact that he was in possession of the only complete copy of Trithemius' *Steganographia*, arrived to his hands in the quite mysterious manner that we have already narrated. These revelations caused singular surprise in the noble listeners, who were puzzled by the vulgar appearance of the stone mirror and the fact that nothing was seeming to occur when observing its burnished surface. If what John Dee said was true, they were in the presence of something truly magical and sacred, a kind of window to the other world. But how did this window open?

How were the angels, described with such precision and detail by John Dee, evoked? Perhaps by invoking a magic formula, as necromancers do? Or by drawing up Kabbalist signs in the style of Hasidic Jews? These and a thousand other questions were boiling in the minds of the Germanic nobles as John Dee, imperturbable, was continuing with his exposition.

"This is, Señores,"⁴¹ the English sage was vehemently affirming, "how I managed to solve the enigmas posed by Trithemius' *Steganography*. There is now a knowledge that can transform the world, eliminating the distances that separate men from each other and forever banishing the pain of disease and misery: it is the Hyperborean Wisdom. Such a wisdom can only be interpreted when man *has situated himself* in such a way in relation to the world that it seems to lose the power to act upon him. Such a condition is obtained after a blood purification, for in the blood lies the cause of the confusion in which we struggle. But when one has succeeded in avoiding

41. It is said that Rudolf II preferred speaking Spanish, among other customs, including his way of dress, being that much of his upbringing was spent in the Court of Spain.

the confusion, when one has *reoriented* the sight toward an interior and personal point, called *Vril*, which seems to be the only thing that possesses true eternal existence in man, all else being pure illusion, then the darkness dissipates and it is possible to access the Hyperborean Wisdom as I myself have done. But this knowledge can only *remain* in this world if it is contained in the language of the birds, in that Hyperborean language that is also called *Enochian*.”

The talking stone was now next to the nobles, momentarily forgotten. Emperor Rudolf II and Wilhelm von Rosenberg were listening with lively interest to the concepts that the English sage was pouring out. Neither of the two tried to interrupt him, prudently saving their questions to be formulated later. John Dee, after fixedly observing his interlocutors for a moment, perhaps to make sure that he was understood, continued with his explanations:

“It is necessary for me to warn you that a conspiracy hangs over my work. It is carried out by some demons who inhabit an infernal place called Dejung, about which I have often been alerted by the angels, but so far I have not come to understand their mystery. It is evident that these infernal beings possess disciples among the men who faithfully fulfill their orders, but I have not learned to distinguish them, and it is hard to believe that their power is so great that they have infiltrated the highest spheres of government. However, I must think that this is so because my sovereignty, Queen Elizabeth I, has behaved strangely after becoming aware of these mysteries, and I would even say contradictorily, ignoring that many of my investigations obeyed her express request. A climate so negative for my interests was formed in England that I came to fear for my life; and if I managed to save it, it has been surely due to the intervention of the Hyperborean Siddhas and your Pure Blood, Majesty, which has impelled you to insist before Elizabeth I. I also do not know to what extent the demons are capable of acting here, in Prague. But the fact that I have arrived in good condition, carrying the stone and the valuable manuscripts, is an encouraging sign. You should know that I have come to distrust my own wife and my accompanier Kelley, to give you an idea of how suspicious I am of everyone. But now, in sharing your presence, I feel that there is a great possibility that the Hyperborean Wisdom may one day transform

the world, paving the way to immortality and the return to the primordial paradises.

“For all these reasons that I have given you, generous Emperor, I wish to make you a request. Being that it is indispensable to preserve the Hyperborean Wisdom, just as the angels order and as reason also advises, I propose that you designate, in the greatest secrecy, one or several trustworthy persons, this choice subject to my approval, so that we may proceed with the investigations. It is also necessary to have a place safe from prying eyes, where this plan can be realized with prospects of success. If you agree, prudent Emperor, you will do a great work that your descendants alone will be able to appreciate and that will have the blessing of the angels. Emperor Rudolf II: I am not exaggerating if I tell you that the redemptive work of Cristo-Luz is in your hands!”

Rudolf II and Wilhelm von Rosenberg remained silent and pensive for a few long minutes. It was evident that they were so impressed that it was difficult for them to speak after John Dee’s account, which had gone on for more than two hours. At last the Emperor fixed his eyes on the English sage and said resolutely:

“Prove to me all that you say and you will obtain all the support that you have requested of me.”

Such a condition was no doubt expected by John Dee, for he hastened to say:

“There is no impediment for men as noble and pure as yourselves to be able to participate in the terrible mystery of the Hyperborean Wisdom. You ask me for a proof? Your own mutation will be the best proof. Because I will bring you face to face with the angels and they will put an end to all doubts and misgivings. Before their exalted presence nothing impure can exist, *but what is left of you afterward* will be good and beautiful.”

After uttering such insinuating words, John Dee requested a bucket of water from the Vltava, which was immediately sent for. They were in the highest room of a round tower, adorned on its only circular wall with four ogival windows through which the magnificent starry Bohemian sky could be seen. In the northern window, sharply silhouetted, a two-horned moon was adding a certain oriental charm to that fantastic scene. As soon as his request was fulfilled, the English sage began to work with the water of the Vltava. First, he removed the carpet

that was covering the coarse flagstones and then, making use of a paintbrush, he drew a circle with the water, inviting the curious nobles to *situate themselves* within it. Having done this, he traced several *runes*, always with water, on the interior of the circle, and on the chest of each one of the knights. Quickly, he extended *outside of the circle* a green cloth that he extracted from his clothes and placed Princess Papan's stone mirror on it.

With such preparations fulfilled, John Dee looked around the room and at the two Germanic Viryas who were remaining in suspense. The result of this inspection must have been to his liking, for, nodding in approval, he said:

"Well, Sire, Emperor of all the Germanies, you are now going to hear the Enochian tongue, which will make the angels present themselves, for that is the secret of the mirror. The angels only respond if you have previously *pronounced the right words*, if you have demonstrated to possess the mastery of the language of the birds. Pay attention to what *you see*, Emperor, but also to what your Pure Blood *tells* you! The same goes for you, noble Burgrave of Bohemia." Having said this, John Dee introduced himself into the interior of the circle of water and began to speak in the Enochian tongue.

Accustomed to witnessing the failure of numerous demonstrations of magic and alchemy, the Germanic nobles could not prevent a certain prior skepticism from settling in their hearts. But when John Dee emitted the first syllables and they both realized that those sounds *could not* be human, a growing sensation of dread was simultaneously assailing them.

The nobles began the experience with their eyes fixed on the Aztec stone, strangely contrasted by the green cloth; but when John Dee's words rose up in an irresistible harmony of *living sound*, they thought to sense a symptom of dizziness. Rudolf II was the one who first looked to the sides, outside of the circle of water. And the spectacle that he then witnessed made him tremble, completely surpassing his capacity for astonishment. The water of the circle was strangely glowing and seeming to burn at times. In fact, something strange had occurred with the water, for it *damaged* the stone of the floor, leaving a circular mark that can still be seen today, four hundred years later. But that was not the strangest thing, but something *that had to do with "movement,"* or at least Rudolf II thought so, for that room in the tower that was constituting the

exterior reality of the circle, its surroundings, was seeming to have picked up speed to such an extent that the adjacent things were losing their form and were becoming diluted before the astonished eyes of the nobles. Everything was seeming to *vibrate* with great speed, becoming blurred and transparent, although in a moment of lucidity the terrified Emperor thought that perhaps he was the one who was *stopping*, that something in him was losing speed or *was going backward*...

Only John Dee's voice, the circle, in which they felt blissfully safe from the growing chaos, and the stone mirror on the green cloth were remaining constant. The mirror was looking, now that everything exterior to the circle was becoming hazy, strangely sharp and incredibly alone. This phenomenon continued until, outside of the circle of water, nothing could be distinguished except the stone mirror, surrounded by a green luminosity that Rudolf II attributed to the invisible presence of the cloth on which it was deposited. But one would be deceived if he believed that these *reflections* were indicating some serenity in the two nobles or were a sign of reasoning. In reality, they were concepts that were stupidly welling up in a rational conscience on the verge of dissolution.

That consciousness that we use daily in order to live out our daydreams, characteristic of *strategic confusion*, is sustained by a multifaceted "I" that is pure mechanicity. There is no stable ego, which remains beyond the questions proper to rational dialectics, but a multiplicity of "I's," *contingent*⁴² as far as their appearance, but immediately *determined* by the mechanics of the brain. And after the succession of "I's," the only permanent thing is, ironically, the *illusion of being*. That "*believing to be*" (someone or something) that keeps us in the strategic confusion of a completely illusory world, but which, nevertheless, we blindly affirm as real. That is why the ordinary rational consciousness, its "I," is the first concupiscence that poisons the Virya's immortal Spirit. And that consciousness was that which was on the verge of dissolution in our heroes, and to which isolated concepts, "loose" reflections, were arriving. Like sparks, which were glowing an instant and then dying, so were the ideas emitted by the dying "I's," the "*reflections*" that we were mentioning in the previous paragraph. But such a dissolution of consciousness was far from representing a fall into

42. Subject to chance; dependent on circumstances.

the unconscious, a loss of sense. On the contrary, a *higher consciousness* was becoming present, affirming itself beneath the tatters of ordinary consciousness. The epicenter of the phenomenon was in the blood; and its triggering factor was undoubtedly the Enochian language that John Dee was still imperturbably reciting.

What was he saying in his discourse? *They could not yet understand it.* But the words uttered, wisely intoned, were producing in the listeners an unmistakable sensation of reminiscence. When John Dee began to speak, after the initial surprise, Rudolf II found himself thinking: “how had I forgotten this language?” He was sure that he had heard it before, but where? When? It was maddening to witness the struggle between *reason* and *gnosis*. Reason *was assuring* that he had never heard anyone speak in the Enochian language; and gnosis was opposing *the certainty* that this had indeed occurred. And while the reality exterior to the circle of water was being weakened, reason was yielding its strength to the gnostic content of the blood, which was becoming more and more present. It was seeming as if the blood took on a greater pressure and rushed to the temples of the head; yet it was not so, but one could *feel with the blood* and *feel the blood*; and this new-found *consciousness of the blood* was generating the *apparent sensation* of pressure or obnubilation. Finally, there was something like an interior burst; it was only an instant in which Rudolf II saw everything red and felt himself falling into a liquid torrent, and a sensation of cold fire pervaded all the spheres of his being. That explosion signaled the definitive abandonment of ordinary consciousness and of his rational “I’s.” And the sensation of falling into a liquid torrent—which was, we repeat, only for an instant—was actually the replacement of the ordinary consciousness of the Paśu, which we call *rational consciousness*, with the *gnostic consciousness* of the awakened Virya who is on his way toward mutation. That is why Rudolf II, who was, for an instant, the liquid torrent, was now *all consciousness*, without physical limits of any kind. He was clearly presenting the *pure possibility* that would signify *reaching the Origin* and he could almost see the uncreated worlds, the un-existent flowers, which would come forth after the conquest of the Vrīl.

The Vrīl is the possibility—the only possibility—of being; but it also signifies *pure possibility*: from the Vrīl, everything is

possible, starting from the uncreated, from what is to be done. The Vrīl is, thus, absolute and eternal individuation. Its conquest signifies the definitive abandonment of the Demiurge's world, of his perpetual deceptions, of the enchainment to His damned and idiotic law of evolution. *Nirvana, samadhi*,⁴³ nihilistic contemplation, the identification with the pantheistic world, "feeling God in all things," and any other form of participation with the Plan of The One imply, in the long run, *phagocytation* in His Exalted Belly and the death of the individual consciousness. The Vrīl, on the other hand, is the only possibility of being and is, at the same time, pure possibility.

We were saying that Rudolf II, who by his intuitions was already on the verge of mutation, was, at a given moment, "all consciousness." For him, there was no longer any physical body, and if he was still hearing the words in the Enochian language, said hearing was certainly not occurring by means of the physical ear or by any other sense. Rudolf II was clearly aware of all that was occurring around him because, after the brief explosion of blood, his lucidness was seeming to have multiplied to a point never before experienced by him (not even when he was eating the hallucinogenic mushrooms that Hagecius brought back to him from America). And this *omnipresence* of the Emperor, we wish to clarify, was not motivated by an unfoldment, like the magicians of India and Tibet practice. The "leaving of the body," the "astral travels," the "unfoldments of consciousness," feeling the "etheric body," the "astral body," or the "perispirit," etc., etc., *have nothing to do with the Hyperborean Wisdom*. These phenomena, real to a certain extent, are *satanic tactics* that do not offer *any possibility of liberation* but, on the contrary, produce a greater confusion in the Virya, since they extend the confusion to other planes.

Whoever practices "unfoldments" and "astral travels" will surely be entertained for a long time, but it is inevitable that such a foolish attitude will eventually lead him to be phagocytized by his "God."

The experience that we are narrating does not possess points of contact with the usual exoteric falsehoods of the Synarchy. It should be interpreted in light of the Hyperborean Wisdom as a "gnostic initiation by Pure Blood," and the word

43. These terms are taken in the meaning that Buddhism gives to them. We make this clarification because in Kaula Tantrism they are given another, more ancient meaning, which could be considered acceptable to the Hyperborean Wisdom.

“blood,” and all that we say about it, should be taken in a *symbolic and analogical* sense.

In that state of omnipresence, Rudolf II was still hearing the Enochian words that had torn him from the illusory world in order to transport him to the only enduring thing in him, he now knew with certainty: the gnostic content of the blood. And this *content*, which is nothing more than a memory, but that without it we would only be an animal-man, a Paśu, produced, at first, an indefinite reminiscence. The reminiscence, that is to say: the Minne, without being very clear, induced a sentiment of nostalgia for *that which* the content of the memory *was alluding to*; and this sentiment was becoming so intense that it ended by transforming itself into anguish. This feeling—perhaps the last human sentiment that was still left in Rudolf II—was accompanying him when, in his omnipresence, he was listening to John Dee pronouncing the Enochian language. And this we emphasize because as the speech went on, a mixture of anguish and pleasure was affecting the Emperor. As when the greatest love produces in us the sensation that our chest is going to split open and not even the presence of the beloved woman is able to mitigate this feeling, a mixture of pain and pleasure, so also John Dee’s voice was submerging the Emperor into the anguish of the lost Origin and into the present joy of hearing the evocative word.

We must now clarify that anguish has its dark origin in fear. And both anguish and fear are feelings, i.e., vibrations of the “emotional body” of the Paśu. The awakened Virya, in order to achieve the mutation of his human nature into that of a superhuman and to conquer the Vril, must first abandon all feeling, all emotion. After he obtains the Vril, he will be able *to create* for himself the *witnesses* that he needs in order to exalt his creation and, if he so deems it convenient, he will have as many feelings and emotions as he wants, without limits, *dreaming* of whole universes of *emotion*, of worlds of poetry, and nameless love. But while one remains in the universe of the Demiurge, it must be kept in mind that all emotion *is borrowed*, it comes from the vibrations of an astral body of energy, associated with the physical body, designed in order to favor the *evolution of the Paśu*. That is why the Hyperborean Wisdom teaches that “fear is a strategic weapon” and that “emotions are the most *vicious* mode of illusion.” Every emotion, love, fear, desire, etc.,

is *shared* with the Demiurge because it is generated in a body formed of pantheistic matter.

The “memory,” any memory, causes diverse emotions associated with the idea that it actualizes. We are all capable of smiling upon “remembering” the good moments lived, as well as involuntarily becoming embroiled in anger, pain, bitterness, etc., of reliving negative experiences that we were believing buried in the past and that the “memory” has suddenly turned present and actual. We all know this and it seems obvious to point it out. But “*the Minne*,” as a *memory* contained in the blood, also *causes* a feeling of nostalgia, necessary in order to pull the consciousness out of the confusing world in which it is immersed and *to motivate it* to seek the Origin. But this nostalgia and every subsequent feeling is abandoned upon visualizing the route toward the Origin and realizing that the Spirit is *alien to the world of the Demiurge*. It is reasonable, then, that upon receiving the Minne, nostalgia is experienced, but this should never degenerate into anguish or any other feeling, because in that case one would be in the presence of a new strategic confusion.

The Hyperborean Wisdom assures that the nostalgia for the return is an *uncreated feeling* and, therefore, *not determined* by the laws of the Demiurge. When perceiving the Minne, nostalgia is experienced, a true arrow drawn toward the return, but this “feeling” is the only one that *does not originate* in the astral body, but in the blood. Perhaps nostalgia is also a memory, but the truth is that everything related to it remains a mystery. Now, it should be kept in mind that, according to Hyperborean Wisdom, the awakened Virya, i.e., the one who has experienced the Minne, *does not yet exist*, but has the possibility of existing, so long as he moves toward the Origin and his implicit mutation. “Fear is a strategic weapon” much used by the enemy and that is why, when the Virya *glimpses the Origin*, fear immediately assaults him. The part of his body that participates in the pantheistic world of the Demiurge reacts against gnosis by inducing the Virya *to project himself* in time, as a tactic of confusion. Fears of “not making it,” of “losing time,” of “losing face,” etc., are all originated in the illusory projection of consciousness into time (past or future), believing that one can “calculate” or “foresee” what will occur. That is why the Virya must be intrepid and audacious like Nimrod if he truly wishes to triumph. Any “calculation” or “speculation” has un-

failingly been induced by the Demiurge; it is His tactic to provoke fear. And all fear is always of an “external” origin, alien to one’s own being.

We have stated all this so that it will be clear why, in the course of the experience that we narrate, the noble Wilhelm von Rosenberg went further than Rudolf II by succeeding in transmuting himself into an Immortal Siddha. The deep-seated sentimentality of his Jesuit Catholic upbringing and the consequent impossibility of avoiding confusion, even on the verge of mutation, was detrimental to Rudolf II. He was an awakened Virya, and from that day on he would be even more so, but *his heart was predominating over his Pure Blood* and this error cost him his individuation.

What occurred can be synthesized like this: both nobles experienced a similar psychological process when John Dee pronounced the words in the Enochian language. And both experienced the “explosion” that was preceding the abandonment of rational consciousness and the “fall” into the liquid torrent of the Pure Blood. Then, Rudolf II was transformed into an omnipresent consciousness that was enjoying hearing the forgotten language and was suffering, at the same time, the anguish of the return; i.e., Rudolf II was adopting a *contemplative* attitude toward the phenomena that was affecting him so intimately. On the other hand, Wilhelm von Rosenberg, having reached this point, rushed toward the Origin (if a psychological *action* can so be said) without hearing or seeing, closing himself to all sensation and to all thought outside of the firm determination to return. And this audacious spiritual stance is the perfect expression of the *strategic orientation* achieved by a Virya who *can no longer be deceived*.

If there were a heaven with cherubim for the Hyperborean Viryas, surely they would sing “hallelujah,” praising the intrepidity of Wilhelm von Rosenberg. But there is not. And only we, the Viryas still enchained by Jehovah Satan and His demons, can applaud this display of supreme courage that signifies conquering the Vril, because, we have already said, it means *the horror of contemplating the indescribable face of the Demiurge*.

Wilhelm went beyond where Rudolf II had stopped and, from omnipresent consciousness to omniscient consciousness, revealing, to the thousand eyes of his Pure Blood, the forgotten truth, *which is All Truth*. In an instant, *he understood everything*

and the words in the Enochian tongue of John Dee became miraculously intelligible...

Hallelujah, Wilhelm von Rosenberg! Hallelujah to the one who has launched himself into the conquest of his right to exist. *And who already is, forever.*

Wilhelm von Rosenberg's attitude was of active participation in the process of his own redemption, or, said in other words, "gaining a strategic position, affirming himself in it, and fearlessly charging forward to the assault on the final fortress." But Rudolf II, who yielded to passive contemplation and was *invaded* by anguish and fear, failed to go back up the path of return, suffering the painful condemnation of remaining in strategic confusion.

We want to say something about "action" and "passive contemplation," which we have cited as the attitudes of Wilhelm and Rudolf II, respectively. It should be kept in mind that the "action" mentioned here is a *psychological attitude*, different from the concrete or physical action that characterizes the "path of action" of the *Mahabharata* or the "warrior's decision." In order to address *concrete action*, it is necessary to previously adopt a set of strategic guidelines similar to those that we have briefly mentioned in the story of Nimrod. But it is worth remembering that the Hyperborean Wisdom suggests *to not undertake any action* unless it takes place in the framework of a Hyperborean Mystique, a matter that will be dealt with in the Fourth Dissertation. Any other concrete or physical "action" will be very easily capitalized on by the enemy; for, without strategic guidelines, the movement will be erratic and confused, ending up favoring the Synarchy. In fact, every action aimed at the search for a "guru" or an "Esoteric School" culminates in some dependency on the worldwide Network that the Synarchy has set up. Therefore, the following recommendation applies: refrain from taking action if the pertinent decision has not emerged from the Pure Blood. Instead, the Hyperborean Wisdom unreservedly advises *interior action* for, whatever direction or meaning that it may follow, it can only ultimately lead to the perception of an infinity of real paradoxes, and these will alert the consciousness to the failures of reason.

Lastly, let us say that "passive contemplation," as an interior psychological posture or an expression of exterior conduct, is always the product of strategic confusion and should be re-

jected like any other concupiscence. When the Virya abstains from exterior action, by following a strategic guideline, this does not signify that he has adopted a contemplative attitude but that, on the contrary, he has become pure potency, he has acquired the quietude of the drawn bow that awaits the moment to shoot the arrow, of the weaponed arm an instant before delivering the mortal blow. There is a quietude, but no one should be deceived: there is also action in potency, since to be an awakened Virya is to have adopted a *state of irreversible alertness*.

Let us now return to the round tower, where John Dee was evoking the Hyperborean angels speaking in the Enochian language. The psychological processes that we have presented in some detail occurred in a *time proper* to the circle of water, which was moving at a different rhythm than exterior time. A *temporal desynchronization* had occurred, also necessary for the effective mutation, and that is why, although the valuable Praguian clock that was resting on a small table was indicating that only five minutes had elapsed, within the circle the passage of time was noticeably greater. Be that as it may, what is certain is that an exterior observer would have assured that the ceremony initiated by John Dee had reached its climax in about five minutes. It was clear that the two Germanic nobles were indifferent to the passage of time and that they were no longer perceiving anything of the reality exterior to the circle of water. Only the voice of John Dee and the image of Princess Papan's mirror were coming to them sharply. But the microclimate in which they were immersed was inducing in them a growing sensation of tension and expectation that was precisely revealing that the ceremony was reaching its climax. And it was at that moment of unbearable tension that John Dee's voice was elevated and his words seemed to evoke forbidden names, the primordial denominations of those who accompany Khristos LúCIFER while they await the return of the Viryas: Anael, Kus, Apollo, Viracocha... And then, emerging from a flash of blinding green light, exactly from the place where the Aztec stone was laid down, two Presences made their appearance... and spoke. How to describe these exalted Hyperborean Siddhas if the mere sight of their faces was almost putting an end to the lives of Rudolf II and Wilhelm von Rosenberg? It is not possible to depict beings so pure without a grave risk of threatening one's sanity. For if one still possesses anything

human, animal, Paśu, if one professes any dogma, any moral, if one experiences any attachment to matter or to the work of the Demiurge, if one harbors in the heart any feeling in favor of or against something or someone, if any of these things affect our Spirit, then it is better to ignore the divine images of the Unknown Superiors, for one's mental equilibrium will be in danger. The light of the Hyperborean Siddhas must be *insinuated* to the Viryas, for those who are enchained to the material world, i.e., in strategic confusion, would not be able to directly resist the terrible Presence that will reveal to them, by that act alone, their miserable condition as slaves of Jehovah Satan. For if this were to occur, from the depths of their misery would arise *Honor*, the only morality of the Hyperborean Virya, and this primordial instinct would strike him like a bolt of lightning.

That is why, when the Germanic nobles found themselves in front of the Presences, only Wilhelm resisted the terrifying ordeal without losing consciousness, although his hair turned white as ash and he wore it that way until his death. Wilhelm resisted because minutes before he had reached the Vril and was already a Siddha himself. And if he was still there, it was because his *omniscience* had revealed to him that his presence would be necessary for the good of the Race, helping John Dee in his mission. On the other hand, Rudolf II, who had failed in his attempt to reach the Origin, was still very much human; and when confronted with the divine Presence and Their Word, he was overcome in his capacity to resist fright: with a sharp cry of terror he fell fainting.

It was a terrible and harrowing cry that the German Emperor emitted. So loud, that it provoked the hurried entrance of the men who were standing guard downstairs. And this irruption put an end to the experience. The surprised and gruff soldiers witnessed an unusual spectacle upon entering the upper room of the tower: those who entered first believed to see in the center of the enclosure something like a circle of fire and smoke that was rotating violently and, within it, blurrily, some persons were seeming to be moving. But the igneous effluvia that were enveloping those present quickly died down, and it could be seen that the Emperor was still on the floor, attended by Burgrave Von Rosenberg, curiously gray-haired, and by the foreign guest.

Hours later, in the royal bedchamber, the Emperor was looking pitiful; he was boiling with fever and at times was sitting up with bulging eyes and shouting unintelligible phrases. Then he was roaring with laughter or bursting into hysterical sobs. Doctor Hagecius, more concerned with his own future than with the Emperor's health, was insistently interrogating Burgrave Von Rosenberg:

"You must know what has happened to him, Burgrave. You are wrong not to trust me, for perhaps the Emperor's salvation depends on what you can tell me." He was lowering his voice so that John Dee, standing at the foot of the bed, did not hear. "If it is a spell that the Englishman has cast, know, noble Lord, that we can annul it. Or we can force him to confess his magic. I believe that you must speak before it is too late."

"The foreigner has done nothing wrong," affirmed the Burgrave with annoyance. "He has narrated part of his investigations to us, and this account, due to its realism, has strongly impressed the Emperor."

"Well, he has been convincing!" exclaimed Doctor Hagecius with irony. "His eloquence must be as good as that of Cicero, the Roman."

"You commit a grave error in mocking and doubting my word, for things have occurred in the manner that I have told you," replied the Burgrave in an offended tone. "The Emperor will confirm this to you when he recuperates; for, I assure you, his illness is a passing thing. He only needs rest, and you would do well to procure his sleep with some herbs."

"You must forgive my zeal," Hagecius apologized, "but it is the Emperor's health that concerns me and makes me discourteous. And your appearance? Have you looked in a mirror? You are a mess, Burgrave! Your hair has grayed twenty years and your face is not far behind. Look, I do not wish to offend you, but you ought to remember that I am an old doctor and that I have seen all sorts of ailments. Once, many years ago, I attended to a poor peasant who had been frightened by a bear. The man was threatened by some gypsies that he would be hexed and the devil would pursue him. One night, when he was returning from his work, he felt the presence of someone behind him. Upon turning around, he remembered the threat of the gypsies; and when he saw the enormous body that stood before him, he had no doubt that he was in front of the devil. Fortunately, the shriek of terror that he emitted drove away the

beast; but look how curious it is that his appearance after such a trance was similar to that which the Emperor now presents. That is why I believe that, apart from hearing what the Englishman was recounting to you, you must have seen something...”

“We have seen nothing,” the Burgrave vehemently affirmed. “No devil visited the tower while we were there; and I repeat to you that the Emperor will soon recuperate.”

“Your confidence in his recovery amazes me, since you are not a physician,” said Doctor Hagecius with renewed irony. “But in one thing I will listen to you: I will administer poppy juice to the Emperor... and I will call Scotus so that he may perform an exorcism.”

Thus concluded that unforgettable night: Rudolf II submerged in the slumber of the poppy while Scotus was performing his exorcist rites; Wilhelm von Rosenberg and John Dee, now comrades in the same “closed circle,” planning for the future; and Hagecius, Kelley, and the Papal Nuncio *Georg Popel von Lobkowicz* conspiring to liquidate John Dee...

But let us leave these earthly personages for the moment and return to the tower, an instant before Rudolf II emitted his terrible cry. We said then that the Hyperborean Siddhas had spoken. Can we know what they said? Will it be possible to gather, at the very least, a pale reflection of those eternal voices? We will only try *to insinuate* their message. But first it will be necessary to say something about these magnificent Presences. It will be very brief, for nothing need be added to the grandeur that the mere mention of their names evokes in the Minne of every Virya.

To begin with, it should be made clear that these were not the “angels” who usually *communicated* with John Dee in England and whom he had not been able *to contact* for some time, curiously since Kelley’s “chance” appearance. Those from Prague were infinitely more terrible beings than those whom he saw in the stone mirror, back in beautiful *Albion*. And their surprising manifestation immediately enlightened John Dee, that finding himself in Europe and next to the Emperor of the Germanic peoples, was greatly changing the conditions of his experience or, rather, affecting the quality of it. For one of the Siddhas was He whom the North Germans call Odin, but whom those of the East, the ones who were guided by Him from Mount *Elbrus* to *Europe*, more properly call Wotan, the

Lord of *Valhalla*; the terrible and overwhelming presence of this Divine Hyperborean whose distant *memory* is firmly engraved in all Germanic people. However, although this image of Wotan was sublime and impacting, the one who was truly instilling a paralyzing terror was his *Kamerad*, the Divine Hyperborean Anael. This absolutely igneous Being, also known as the Lord of Venus, was inducing, with his resplendent and flaming Presence, the immediate perception of an order alien to the material Universe, of worlds, the vision of which is forbidden to the slaves of Jehovah Satan. For if Wotan, the ancient Hyperborean guide of the Germanic peoples, will be the one who raises up, henceforth, those peoples and wins over, in that rebellion, the whole Indo-Aryan White Race until the end of the Kaly Yuga, Anael is the Lord who will act during the decomposition and the catastrophe in which the *Götterdämmerung* will manifest itself here, on Earth. He is the one who will guide, in the dark days of the West, the Asian Hyperborean peoples of Yellow Race until placing them at the forefront of humanity through the *National Socialist* alliance with the Hyperborean peoples of Africa and Latin America. But that will be after terrible struggles, when the millenary and satanic work of the Synarchy is visible and the end of the Kaly Yuga ensues. Then a new civilization will be born, the head of which will be in the South, possessing the most ancient secrets of the Hyperborean Wisdom, and entirely dedicated to the search for spiritual liberation and *collective mutation*. It will be in that epoch, after the Synarchic work has been destroyed and the sufficient *strategic advantage* has been achieved, that the Hyperborean Siddhas will return to show themselves to the sight of the Viryas, accompanying that planetary event, which will mark the definitive end of *spiritual slavery*: the Parousia of Khristos Lúcifer.

We have already said, just now, who the Hyperborean Siddhas were, who, on that night of 1585, manifested themselves to the sight of John Dee, Rudolf II, and Wilhelm von Rosenberg. Let us listen now, let us try to do so by appealing to the *memory of the Pure Blood*, to what the Exalted Beings said. They were words expressed in the *language of the birds*; concepts that we will hardly be able to *insinuate* in profane languages, more suitable in order to compose the showy and deceitful *slogans* of the Synarchic Strategy than to expound transcendent ideas. That is why we demand prudence when read-

SECOND DISSERTATION

ing what follows, since we have tried to express the inexpressible, with the sole intention that *it not be read in order to learn but to remember, each one's own version of the truth.*

Epilogue to the Adventure of Dr. John Dee



fortnight after the narrated events, Rudolf II was sufficiently recovered as to receive his visitors by standing up. The Emperor's illness, the news of which had been quickly divulged by friends and enemies, gathered around his bed a constellation of personages, some of them moved by the sincere concern of seeing his health broken and others, most of them, impulsed by dark and unmentionable ambitions. Among the latter stood out, undoubtedly, his brothers Matthias and Maximilian, who were ardently desiring to succeed the alchemist Emperor. But, as has been said, Rudolf II recovered quite well, although this improvement, according to Hagecius, was not complete, since the Emperor was spending most of his days in the Tower where he suffered from the fainting spell that had bedridden him.

He used to remain there for hours with a blank stare, and it was not unusual for him to burst into bitter lamentations that no one was understanding. This state of affairs went on for several weeks, during which the efforts of those close to him in order to combat such a deep melancholy were useless. Not even the favors of his mistress Kateřina Stradová nor those of other kind ladies whom Scotto used to present to the Emperor were able to keep him away from the Tower. Finally, after two months of bitter reclusion, it was his faithful friend Wilhelm von Rosenberg who managed to make him reflect on the downside of continuing with such behavior.

The Bohemian nobleman, in all this, had taken care to protect John Dee upon whom the most insidious gossip had fallen. However, as the Emperor recovered, John Dee's former prestige was prevailing over intrigues and superstitions and soon the English sage was seen giving lectures at the University of Prague and visiting many castles where some noble and cultured interlocutors were attempting to wheedle his secrets out of him. But John Dee was by no means wishing to increase his dubious celebrity, for the risk of irritating the Catholic party was growing. On the contrary, his greatest hope was that Rudolf II would agree to save *Steganographia* and the Enochian manuscripts.

“Prove to me all that you say,” the Emperor had promised, “and you will obtain all the support that you have requested of me.” As John Dee was thinking, the presence of the Siddhas constituted a definitive proof of the truth of his claims. It was now up to the Emperor to keep his word. And that this would occur, “there was no room for doubt,” said the nobleman Wilhelm von Rosenberg, who at all times was manifesting a joyful optimism about the success of the adventure.

So it was that one evening the following dialogue was struck up between Rudolf II and Wilhelm, whom the former had stubbornly refused to see since the night on which he fell ill.

“Dear Rudolf,” the noble Bohemian was beseeching, “by the friendship that we have professed to each other since the days of our childhood, by the memory of the many adventures that we have taken together, finally, by the terrible secrets that we share, I beg that you, taking into account these affinities, which conclusively prove my eternal fidelity, accept the advice that I have come to offer you.

“You must overcome the sorrow that overwhelms you, for which I alone know the reason, and return to courtly life. Otherwise, you will do yourself irreparable harm, for you run the risk of sinking into the darkness of madness. I know how much you suffer because of the lost opportunity and how much the sentences of our guide Wotan weigh on your soul...”

“Do not remind me of it!” cried Rudolf II, despairingly sinking his head into his hands.

“...but what’s done is done,” Wilhelm von Rosenberg continued without noticing the Emperor’s interruption, “and now we can only think of the future. The task that awaits us is very important if we want to work for the good of the Race; but it can only be done, it can be affirmed, if we can count on your support. Otherwise, all will be lost, beloved Rudolf, ruler of the Germanic peoples...”

“Do you really believe so?” asked the Emperor, with a gleam of hope lighting up his light blue eyes. “Is it possible that there is still a way to serve the terrible Gods that the Englishman has evoked, and more importantly, to avoid their wrath?”

Rudolf II had visibly turned pale at the mention of the Hyperborean Siddhas; but, now more refreshed, he continued speaking to his dear friend Wilhelm von Rosenberg:

“If this is so, if you think it possible, you can count on my willingness to carry out the Englishman’s plans and thus ap-

pease the wrath of the Gods. But I tell you, dear Wilhelm, that great is the effort that you request of me; for after the frightful visions that I have had, the ties that bind me to life are not very strong. It will be hard enough for my weak spirit to return to the daily activities of the court.”

“Your decision, wise Archduke, is the most correct one. Be sure that you will contribute like no other to make true the motto of your House: A.E.I.O.U.⁴⁴ In a future, perhaps not far away, from Austria will arise the envoy of Wotan, the one who will raise the Germanic peoples toward the summit of universal power and will unmask the true enemy of the Hyperborean Race before the world. And that great chief, as has been promised, will act so ruthlessly against them that His name will never be forgotten by men. From Austria will be the glory, and perhaps in those days no one will remember you, Rudolf II, for the memory of men is fragile; but rest assured that in Valhalla you will live eternally alongside the most valorous heroes of the Hyperborean stirp. Follow my advice and return to ordinary life. Authorize the Englishman’s work and thereby allow those future good things to come to your House. I assure you, noble Rudolf, that such is the will of the Gods!”

The noble Wilhelm spoke with such vehemence that Rudolf II, led by an irresistible impulse, embraced his friend while pronouncing, moved, these words:

“I will heed what you say, my faithful Wilhelm. In hearing you, I understand that through your mouth speaks someone Higher, and it will not be me who contradicts him. I have been deeply impressed by the events that you know well, and I have almost lost my mind; but now a new light has brought clarity to my Spirit. Await the morrow, so that I may restore my strength through rest, and then we will speak about what must be done in order to comply with that which the Englishman has requested.”

When reading these words it should not be believed that John Dee’s problems were definitively solved. Multiple difficulties were still awaiting the English scholar until he concretized his purpose of ensuring, for future mankind, the knowledge of the Enochian language and of *Steganographia*. This was the will of the Siddhas; and a Hyperborean Knight of noble Wil-

44. A.E.I.O.U. = *Alles Erdreich ist Österreich untertan* or *Austriae est imperare orbi universo*, meaning “All the world is subject to Austria,” the motto of the House of Austria or the Habsburgs since the fifteenth century.

helm's stature had joined the mission to fulfill it together with John Dee. Everything was then seeming to go in that direction, if it were not for the fact that Rudolf II worsened more and more, then showing signs of a strange conduct that went as far as a hostility toward John Dee and an indifference to his mission. With Wilhelm von Rosenberg, his dear friend, he manifested an ambiguous treatment that was intermittently varying between affection and rancor. This latter sentiment was perhaps due to knowing that he was triumphant in the spiritual trials to which they had been jointly subjected. The truth is that the Emperor was showing signs of being profoundly ill, with so strange a malady that, among the many doctors and wise men of his court, no one was able to understand. Clearly, no one knew of the mysterious events that had occurred that night in the Tower. That is why we, who have intimately witnessed the drama of Rudolf II, will try to comprehend his surprising subsequent conduct in light of the Hyperborean Wisdom. In this way, the events that we will narrate later, which constitute the culmination of John Dee's story and, in a certain way, point to the metaphysical origin of the Thulegesellschaft, will become comprehensible.

We have already explained in the previous chapter the reasons for which Rudolf II failed when the opportunity was presented to him, through John Dee, to transmute himself into an immortal Siddha. It is worth adding now that, although Rudolf II was an "awakened Virya" from that experience, his failure to reach the Vril placed him at a *strategic disadvantage* in relation to the concrete world of the Demiurge. The concept of "strategic disadvantage," as well as that of "strategic confusion" and others, will be correctly defined in the Fourth Dissertation. For now it will suffice for us to know that, analogically, a strategic disadvantage is equivalent to a *weak point in a wall*; it is the desperate case of those who, having been besieged by the enemy in a walled Plaza, find to their horror that it is incapable of resisting the enemy's pressure and is ready to give way at a *weak point*. The disaster that follows the fall of the Plaza is analogous to the loss of reason in a Virya with insufficient spiritual support to preserve his health during the subsequent irrational states of consciousness, i.e., madness. On the other hand, the fall of a Plaza Fort never represents a victory for the besieger, but a defeat for the besieged. It is up to the besieged to take responsibility for the fall, for he has failed

to comply with the strategic law that says: “one should never raise a fence if one does not have the means in order to defend it.” Always reasoning analogically, we will say that Rudolf II, after the Hyperborean Initiation that John Dee administered to him, “raised his strategic fence in order to undertake the return”; but by failing to reach the Vrila, he placed himself at a “strategic disadvantage.” The “strategic fence” separates the Virya from the world, granting him the *time necessary* in order to go to his *charismatic center*. On one side of it is the world of the Demiurge with its formidable Evolutive and Synarchic Strategy; on the other, the Virya, authentic monk-warrior, Grail Knight, determined to reach the Truth.

Let us measure the forces at play: on the fence converge, on the one hand, the Synarchic Strategy of the Demiurge and on the other, the Hyperborean Strategy of the Virya, which depends, for its concretion, on the intrepidity and the valor that is risked in order to reach the center; in synthesis, the success of the Hyperborean Strategy depends on the blood purity of the Virya.

We already verified that the Siddhas reproached Rudolf II for his “impurity of blood” and we studied how he retreated at the last moment, losing the possibility of immortalizing himself as a Siddha (a fact that would have changed the history of the West, since Rudolf II was a German Emperor); an opportunity that instead, and happily, Wilhelm von Rosenberg took advantage of. Lastly, let us add that, when a fence has been raised, which has irritated the enemy and led it to concentrate terrible forces for its demolition, it is not easy to go back to the original situation of absence of conflict without being at a *strategic disadvantage*. In effect, when war has been declared, and the enemy has moved its forces, the alternatives are two: either the combat is faced by resisting the enemy siege while *one seeks another door in order to exit*, or the fight is avoided by deferring combat and ignoring the enemy pressure. In this second case, the enemy will increase the pressure in such a manner that the walls will finally give way and disaster will be inevitable; the Strategy itself has failed because it has been replaced during combat. Let us explain ourselves better, but what is said must always be interpreted analogically in relation to the history of Rudolf II who chose, evidently, the second alternative. When a Virya raises a fence, in the framework of a Hyperborean Strategy, in order *to initiate the conquest of*

the Vrill, his Strategy permits him only *one* alternative: *to open the interior door* in order to bypass the deployment of the demonic forces. Only one alternative. The contrary means, plainly, a change of Strategy, and even *Clausewitz knew this: no one can change his Strategy in the middle of the war without risking to suffer grave losses*. In conventional warfare, the most that is admitted in a Strategy is that it offers alternative tactics, but never that it can be changed in itself, which would in reality signify a change of objective (an inadmissible possibility in a Hyperborean Strategy) that would raise severe doubts about the capacity of the General Staff who planned it and even about the validity of the justification that must always be provided for having adopted the warlike path.

But, one may ask, what did it concretely mean for Rudolf II to be at a “strategic disadvantage”? Madness, as we have already said. The madness into which he was effectively plunged in 1590 and that he was only able to briefly come out from in 1601, until his death by *Cold Fire* in 1612. It is clear that the progressive poisoning to which he was subjected to by the Druids, Jews, and other agents of the Synarchy, who were infecting his court, notably contributed to his state of dementia, reached in 1590, five years after the events narrated here. But let us not make any further comments. Let us return to the day on which Wilhelm presented himself, together with John Dee, before Rudolf II, in response to the promise that the latter made to him the day before in order to give a prompt solution to the Englishman’s requirements.

A large crowd was gathered together with the Emperor, hailing his rehabilitation. One could distinguish Duke *John Casimir* of *Saxe-Coburg*; Councilor Stephen Bocskai; Matthias and Maximilian, brothers of the Emperor; the ministers *Wolf Rumpf* and *Paul Sixtus von Trautson*; Nuncio *Georg Popel von Lobkowitz*, head of the Catholic party; the Polish Count *Olbracht Łaski*;⁴⁵ in short, a pleiad of ladies and nobles who were willingly celebrating the physical recovery of the Emperor, without noting the evident disgust that such a scene was causing the opportunistic.

Upon noticing Wilhelm’s presence, a sudden joy illuminated the face of Rudolf II. However, his countenance immediately gloomed, perhaps when recalling the experience in the

45. Also spelled Albertus Alasco or Albert Laski.

Tower; or, perhaps, when realizing that next to him was John Dee, whom the Emperor had grown particularly fearful and distrustful of. Be that as it may, the truth is that he knew how to control his emotions and accepted Wilhelm von Rosenberg's greetings with a timid smile.

"I salute the Emperor and make vows to Our Lord Jesus Christ so that your health may continue to improve," said Wilhelm under the approving gaze of Nuncio Von *Lobkowitz*.

"I see that you are punctual, my faithful Wilhelm," Rudolf II responded without paying any attention to the good wishes expressed by the nobleman. "Yes, you need not remind me. I am mindful of my promise, and if you will be so kind as to tell your accompanier to approach, you will see that I know how to keep it."

At a gesture from Wilhelm, John Dee approached the Emperor and courteously saluted, while several cliques formed among those present, some of whom were approving and others condemning the presence of the "English necromancer" in the court.

"Great wonders you have done, English Knight; and, though my health has been broken, it has not been so broken as to make me forget that we had made a deal, which was witnessed by the noble Wilhelm von Rosenberg, present here. I consider that your magic is proven, and now it is my turn to fulfill what I have promised. I will provide you with what is necessary for you to carry out your plans. I will give amply, but I must ask that you relieve me of one part of the bargain: you will not count on my presence in the future in order to practice the evocation of the angels with the black stone." At that moment Rudolf II shuddered and was promptly held up by his valet *Makowski*. He took his head in his hands and a second later, having recovered, continued in this manner:

"You have expressed the will to practice your science in my kingdom and, although you are a subject of a foreign country, I will give authorization for you to stay as long as you need. I will also place at your disposal the *Benátky nad Jizerou* Castle in which you will surely find to your liking. There is enough there in order to practice Alchemy, Astrology, or any other magical art that you may desire; but, in order to see to it that you lack nothing, I will mandate that you be granted a professor's income at the University. In return, you will only have to give a few lectures a year, in order to enlighten our students

with your learned wisdom. I believe that I have been generous to you, Sir John Dee, but if you wish anything else, do not hesitate in letting me know... Speak now, I am eager to confirm whether you are satisfied.”

John Dee, who was pleasantly surprised listening to the Emperor’s apparently generous offer, did not hesitate to relieve the Emperor of his promise to collaborate in the mission of preserving the Hyperborean Wisdom. This unthinking decision would be disastrous for two reasons: first, because the Emperor’s active participation in the Hyperborean Strategy that John Dee and Wilhelm von Rosenberg were going to implement was perhaps the last chance for him to regain his health; and secondly, because, not being bound by any ties, the Emperor could, as actually occurred a year later, arrange the fate of the English sage at his whim. However, John Dee was not foreseeing any of this when he responded:

“Generous Emperor, you have fulfilled my most fanciful expectations to excess. I can only express my gratitude to you by relieving you of your promise; although I know that with it the mission that I had proposed to you will be deprived of the inestimable help that your participation was signifying.” He said this more out of courtesy than true regret, for he had already made plans with Wilhelm von Rosenberg and was counting on him to carry them out.

“I will give the order so that they escort you to Benátky nad Jizerou Castle,” said Rudolf II after exhaling a sigh of relief upon learning that he could disassociate himself from the plans of the mysterious Englishman. “You may depart at once. As soon as you are ready, go and collect your carriage from the King’s quarters... Oh, and do not forget to take the dreadful stone mirror with you. Makowski!” he called, between energetic and convulsive, to the valet, who, on the other hand, was very close by. “Deliver to Dr. John Dee the green chest that I have safely kept in the *Kunstkammer!*”

A moment later the servant was returning, preceded by a soldier carrying in his hands a small wooden chest, enameled in a beautiful bright green color.

Within this chest, next to the stone mirror, I have deposited a message for your sovereignty, the Queen of England. In it I express to her how much that I appreciate her deference in permitting that a jewel as precious as it is rare, to reach Bohemia. I also informed her that your presence has pleased me,

Dr. John Dee... And now... you may go, "*Also will Ich haben, also gefällt es Mir!*"⁴⁶

Thus, almost with a certain urgency, John Dee was dismissed from the court of Rudolf II. And Kelley? What had become, in all this, of the sinister Druid's fate? After the crisis suffered by the Emperor and his subsequent nervous collapse, Kelley realized that John Dee had made use of the stone mirror; and, fearing that he could convince the Emperor, he began to intrigue, without thinking of the consequences, among the nobility of Prague. In order to understand Kelley's urgency, it is necessary to know or even imagine the terror that these "missionary" Druids felt towards their Chang Shambhala masters. A "Celtic bard" like Kelley, i.e., an initiate in Druidism who has been entrusted with the fulfillment of a mission, could not allow himself to fail for anything in the world: the punishment would be terrible. And Kelley's "mission," may we remind you, was to liquidate John Dee and "recover" his treasures: Princess Papan's stone mirror, the Enochian manuscripts, and *Steganographia*, i.e., the most complete synthesis of the Hyperborean Wisdom ever seen in the Christian West.

It was in this trance that Kelley, unable to enter the court of Rudolf II, and increasingly distanced from John Dee, decides to increase his prestige as an alchemist by performing "transmutation" exhibitions in front of any nobleman who wished to open the door of his palace or castle.

He even traveled as far as the castle of the Prince-Elector of Bavaria, Maximilian, and the no less distant castle of Count Olbracht Łaski in Poland. But when John Dee departed with his wife and son for Benátky nad Jizerou Castle, Kelley's impatience transformed into desperation. So he hatched an ignoble scheme, the aim of which was to deprive the English scholar, as he did in the court of Elizabeth I, of royal support. To this end, he performed at the home of Dr. Hagecius, in 1586, a transmutation so astonishing that, even today, the descendants of the Bohemian doctor remember it and keep the piece of gold, the product of the marvel. Witness to the case was *Nicolas Barnaud*, a renowned physician in Prague, who was also tasked with increasing Kelley's prestige.

46. Formula used by the absolutist monarchs, derived from the Latin sentence "Hoc volo, sic jubeo" ("This I wish, thus I command"), *Satires VI.*, 223, Juvenal.

However, it was not prestige that the skilled schemer was after this time. Stimulated by Hagecius, who was desirous of witnessing an authentic alchemical “showing,” Kelley convinced the royal physician to supply him with some confidential information about the Emperor’s intimate life in exchange for the marvel. Armed with some details about Rudolf II’s sentimental activities, which only the concerned person or those closest to him could know, Kelley took it upon himself to skillfully divulge them throughout Prague, saying that these pieces of information had been “glimpsed” by John Dee using the stone mirror. The intrigue culminated successfully, when, on May 6, 1586, the head of the Catholic party, *Georg Popel von Lobkowitz* lodged a complaint with Rudolf II accusing John Dee of “being a spy for the Queen of England, a magician, and necromancer” and of “enchanted the Emperor with the stone mirror, through which he obtains information about his private life and important state secrets.” Rudolf II’s reaction was not long in coming: he mandated to immediately banish him from Bohemia.

John Dee, surprised by this reaction to some charges in which he had nothing to do with at all, saw himself forced to quickly flee from Benátky nad Jizerou at risk of being imprisoned. However, he did not need to leave the country, for Wilhelm, with whom he was in constant contact, willingly agreed to hide him in his own Castle *Roudnice* in *Severočeský*. But such a situation soon became known to the Emperor, who flew into a rage, and intimidated Wilhelm to expel the “English spy,” and there followed, as the Emperor’s malady was progressing, a series of incidents that culminated three years later, in 1589, when John Dee left Bohemia for good.

In the four years between 1585, the year in which John Dee arrived in Prague, and 1589, the year in which he had to leave the German Empire, several noteworthy events had occurred, some unfortunate and others favorable to the interests of our hero. In the first place, among the negative events, can be counted: Queen Elizabeth I’s increasing insistence that her subject return to London to report back on the espionage that he had carried out, an interest that was stimulated in the sovereignty by Kelley and his henchmen, who were constantly sending news to the English court about the possible treason or defection of the unfortunate sage. Also ominous was the extraordinary update received in Bohemia in 1587 that “un-

known men," perhaps "a fanatical mob," had stormed John Dee's English house in *Mortlake* for the sole purpose of burning his valuable library of alchemical manuscripts and incunabula. Four thousand works had been lost at the time. The real motive for the attack? A desperate attempt on the part of the Synarchy in order to get the sage to leave Bohemia and embark on a speedy return to London. Lastly, to name only those events that caused the most inconvenience, we must not fail to consider the tremendous pressure exerted by Rudolf II on Wilhelm von Rosenberg aimed at getting the latter to stop giving protection to the English sage and to expel him from his castle. In effect, the Emperor, as time went on, was manifesting an increasingly contradictory conduct, finally coming to exhibit an open hostility toward John Dee and unusually demanding his expulsion, even threatening his friend Wilhelm with besieging his castle with imperial troops. All of this contributed to the unraveling. However, the Emperor, who had so strenuously procured to ruin John Dee's plans, one year after the latter's departure in 1590, was succumbing to a state of demented melancholy, motivated by despair and remorse. A dementia from which he would only come out eleven years later, in 1601, during a brief period in which he would try in vain to repair the evil that he had caused, interceding with the Czar of Russia so that he may hire John Dee, whom he knew to be ruined and destroyed in England. Vain help, we say, because the wise Englishman would not return to the mainland for anything in the world, fearful of a new conspiracy. It would be his son Arthur who, years later, would occupy a position as a doctor in the Russian court.

But that is another story. Rudolf II had not, then, even the strength to counteract the maneuvers of his brother Matthias, who in 1608 finally seized the government of Austria, Hungary, and Moravia, or to resist the Druidic plot hatched against him: it is the Polish nobleman and alchemist *Michał Sędziwój* (*Michael Sendivogius*), disciple of the Scottish Druid *Alexander Seton* (*Setonius*) "*The Cosmopolite*"; initiated by the latter in the preparation of concoctions and poisons, who gives him to drink of the "amber nectar" that precipitates Rudolf's death in 1612.

We had promised to mention, in the second place, the fortunate events that happened to John Dee during the four years that he remained in Bohemia; but, in truth, we must now say

that these events have been of so great an importance for the History of humanity that, in the face of them, all that we have narrated of the bad is reduced, in comparison, to mere inconveniences, to simple inconsequential difficulties that do not deserve to be taken into account. Thus they understood, John Dee and Wilhelm von Rosenberg, who took things philosophically and continued unchanged with their mission until the end. We are concretely referring to the provisions and arrangements that both Siddhas made in order to preserve the Hyperborean Wisdom. Because it is in this undertaking, to which both dedicated all their efforts, that we believe it is possible to synthesize what occurred from a single event, from which countless benefits are derived: the founding of the Sapiens Donabitur Astris Order.

The idea of creating a Secret Society was not in the minds of our heroes until 1586, after John Dee, forced to flee from Benátky nad Jizerou Castle, joined Wilhelm von Rosenberg and both of them evaluated, quite precisely, the magnitude of the synarchic conspiracy. Up to then, the English sage had devoted himself to ciphering *Steganographia* into the Enochian language, and to preparing various treatises on this same language: a “grammar,” a “phonetic method,” and a “list of equivalent terms,” i.e., a primitive dictionary. Wilhelm, in the meantime, was deepening the secrets of the Hyperborean Wisdom and attempting to develop a strategy that would allow the preservation of the “supreme knowledge” in order to be used for the good of humanity. They were performing such tasks, of course, without much ado, impulsed only by their own convictions, by the certainty that, in this way, they were complying with the mandate of the “angels.”

It was in 1586, as we have said, when they realized that Rudolf II was yielding to an alien and irresistible Will that was inclining him to destroy that which he was holding most sacred. Rudolf II was yielding to the enemy Strategy and this capitulation allowed the two comrades to correctly evaluate the danger and become aware that it was urgent to find a definitive solution in order to safeguard the Hyperborean Wisdom. Both of them had to find a method that would make it virtually impossible, in that or in any other epoch, to infringe upon the knowledge entrusted to humanity by the Hyperborean Siddhas. And as the ideas that were coming to their minds for solving the problem were many, they decided to elaborate sev-

eral alternatives and submit them to the arbitration of the Siddhas, evoking them through Princess Papan's stone mirror. From such consultations at last arose, in 1587, the definitive Strategy, approved by the Siddhas and perfectly feasible to be carried out by John Dee and Wilhelm von Rosenberg. Let us attentively examine this Strategy because its success made it possible that three hundred years later, in the darkest period of the Kaly Yuga, emerged radiant and august, the bearer of the laurel of Roman victory and the Aryan Swastika of the Return to the Origin, *the Hyperborean Eagle of the Thulegesellschaft*.

Foundation of the SDI Order



strategy elaborated by John Dee and Wilhelm von Rosenberg in 1587,⁴⁷ called the “AI Strategy.”

I. Declared Objectives

- A. To preserve the Hyperborean Wisdom.
- B. To procure that, in addition to preserving the current knowledge (1587), the latter may also be increased over time with new contributions.
- C. To preserve the Enochian language.
- D. To update, in each century, in the greatest secrecy, the Hyperborean Wisdom to the intellectual level of the epoch and to elaborate ways of individual and racial mutation in order to be used at the time when the HHH guideline is fulfilled.
- E. Maintain a permanent observation of History’s progression, recording all the important events of each century from the Hyperborean perspective, paying special attention to the tactical deployments of the demonic forces of Chang Shambhala (Synarchy), but without ever intervening or allowing said observation to be noted by the enemy, save for the exception of the HHH guideline.
- F. In spite of the difficulties that may arise in complying with these objectives, they will be unfailingly carried out by Viryas trained for such an aim, who will travel the world in fulfillment of their mission, but will be previously willing to die on their own at the moment that they deem it opportune, if by doing so they contribute to maintaining the secret.
- G. The objectives will be considered achieved and the purposes for which the AI Strategy was elaborated fulfilled,

47. The JD and WvR Strategy is transcribed in modern language in order to facilitate its reading and comprehension. The original 1587 criterion has not been altered at all, although some concepts have been updated so that they can be easily identified with others corresponding to the context of this work.

when the HHH guideline is produced, the only condition imposed by the Siddhas on the *founders*, John Dee and Wilhelm von Rosenberg.

HHH Guideline: it is a time to come, in which the tasked mission will be considered fulfilled when the Hyperborean Wisdom will be entrusted to an elite predestined to be used for the good of humanity, which will revolve around the *Envoy of Wotan, the Lord of War, the chief who will lead the Hyperborean peoples to victory, the bearer of the polar cross of Khristos LúCIFer*. This is a mystery that no one will be able to decipher before the right time.

II. Feasibility Analysis and Possible Courses of Action

A. In order to develop a Strategy aimed at fulfilling the previously mentioned objectives, it is necessary to start from three rigorously necessary elements:

1. The *men* capable of carrying out the AI Strategy.
2. The *means* necessary so that the right men can carry out the AI Strategy.
3. The *method* so that the men, in possession of the necessary means, fulfill the right steps that may enable them to carry out the AI Strategy.

B. Element Analysis (1)

- The men capable of fulfilling the proposed objectives must meet certain indispensable requisites: Rigorously demonstrable “Nordic” racial purity (Germanic, Anglo-Saxon, Danish, etc.).
- Absolute loyalty to the declared principles; for this, they must answer with their heads.
- To possess exoteric links with each other so that the secret meetings that should be held in order to fulfill the objectives never give rise to any suspicion.
- The men who carry forward the AI Strategy must also be capable of detecting, in advance and with absolute certainty, who will be their followers. These will be selected with such a precision that when the time comes for them to be initiated into the Mysteries of the Hyperborean Wisdom, they will never turn back. Should such a case occur, the *initiate will be executed along with his initiator*. Etc.

It is because of these and many other such requisites that the only possible alternative, for ensuring the supply of suitable men, seems to be forming a co-blooded caste depository of the secret, i.e., an authentic blood aristocracy, guardian and regent of the Hyperborean Wisdom.

Course of Action: this problem was solved in the following manner by John Dee and Wilhelm von Rosenberg. Between them, they chose eight nobles belonging to the purest and most ancient lineages of Austria, Bohemia, Bavaria, Saxony, Mecklenburg, and Brandenburg, initiating them into the Hyperborean Wisdom and incorporating them into the Great Fight.

These initiated princes signed a parchment with their blood, in the year 1589, by which they committed themselves to fulfill the objectives and to respect and enforce the law of secrecy, also establishing a perpetual alliance between their stirps, in such a way that their descendants would always be linked by bonds of co-blood and kinship. Likewise were set, in this protocol, the precise norms that should be followed in matters of matrimonial agreements, leaving totally excluded from the family secret any descendant who could not prove, in any epoch after 1589, the unique blood inheritance of the eight covenanted lineages; i.e., that if any *non-initiated* descendant decided to unite in marriage with a person outside the eight trunks of the Dynasty, *he would not be harassed*; but his progeny would be definitively excluded from access to the Hyperborean Wisdom. In order to fulfill these norms and to avoid irreparable errors among the initiated members of the family, they would commit themselves to carefully keep genealogical books that would unfailingly have to be consulted when celebrating a wedding or at the moment of choosing those fortunate relatives deserving to know the familial secret.

It would take too long to enumerate the formidable provisions made by the eight princes in order to secure the element (i), the men capable of carrying forward the Strategy of John Dee and Wilhelm von Rosenberg. We will only add, in order to conclude this analysis, that as the number of initiated members (for esoteric reasons that we will analyze later) should never be more than 16 nor less than 8, it was agreed from the beginning that they would procure to complete these numbers *even with women*, who would have the same rights to

the Hyperborean initiation as their male relatives. Clauses were also introduced that were taking into account the possible extinction of one of the stirps and were discussing how to proceed in such cases. The parchment, in which this blood pact was documented, was deposited, together with the *Steganographia* and the treatises in the Enochian language, in the old trunk reinforced with steel straps that belonged to Cornelius Agrippa von Nettesheim and that John Dee transported to Prague. For three hundred years, said trunk was the very symbol of the familial secret bequeathed by those eight esoterically summoned princes.

In spite of the precautions taken in order to ensure the future security of the familial Secret Society, a hundred years after its foundation, it was already suspected that it existed. This was inevitable due to certain financial transactions carried out by the initiates, which we will comment on in the following analysis. In the eighteenth century there was talk of a "Society of Alchemists" that would function in the greatest secrecy and exclusively made up of members of the Protestant nobility of Germany, and it was even speculated that it could be the mysterious Rosicrucians or a society of Freemasons. The Catholic Church was the first to suspect and to carry out inquiries, although without major consequences. However, in the nineteenth century, the familial Secret Society was seriously investigated in an attempt to uncover and destroy it. The attack was not now coming from the Catholic Church, which on the contrary had common interests with the Dynasty, but from the *Illuminati*, the sect founded in Bavaria by *Adam Weishaupt* in 1776. This paramasonic society was one of the hidden driving forces that impulsed the revolutionary movements that ravaged Europe from the eighteenth century onward and in fact constituted an important piece in the great synarchic offensive of the nineteenth century. The *Illuminati* was the first serious attempt to destroy Christian civilization; it was using subversive and revolutionary tactics and was proposing to liquidate the blood aristocracies in order to distribute the power among rich merchants and bourgeoisie, and no less rich Jews. It is understandable, then, that the *Illuminati* considered, as mortal enemies, the members of a Secret Society like that which we are commenting on, bearer of the Hyperborean Wisdom, i.e., possessor of the necessary and sufficient knowledge as to counteract the synarchic offensive. And although

only the suspicion of its existence was available, we can say that a terrible secret war was waged throughout the nineteenth century against the Dynasty; the details of which we will not give in order not to prolong the story too much, except for one that we consider highly significant: it was the Illuminists who called the familial Secret Society, SDA, for lack of the true name. The name was taken from the old motto “*Sapiens Donabitur Astris*,” from the coat of arms of one of the eight princes who founded the Dynasty, given that the corresponding heraldic escutcheon was on view in a Prussian castle where the illuminists were supposing that the Secret Society was functioning. As no one ever belied this question, it continued to be called SDA, a criterion which we will also follow hereafter; but not without first clarifying that the initiated members of the Dynasty were using one name among themselves in order to refer to the familial Secret Society.

In effect, the secret name of the SDA was *Einherjar*,⁴⁸ a word that alludes to Odin’s elite and has been used for thousands of years in order to denote warrior-initiate societies.

In any case, as SDA was known to the world, we will continue calling it SDA throughout the story.

C. Element Analysis (2)

- Considering the solution given to the problem of finding the men capable of carrying forward the Strategy—through an initiatic Dynasty—the second element, the means necessary for the initiates to fulfill their objectives, can be reduced to two principal aspects: “*financial means*” and “*logistical means*” (or “*infrastructure*”).

Course of Action: the *financial means*, being a familial Secret Society, could be covered by the personal wealth of the initiated members of the Dynasty. However, this solution did not seem satisfactory to the eight princes because it was generating too many probable alternatives and, consequently, few guarantees of security. For example, what would occur if certain circumstances produced the personal bankruptcy of some of the members? Would it drag the familial Secret Society to its ruin, thus sealing the fate of Hyperborean Wisdom? This

48. *Einherjar*: a term obtained by the contraction of the words *aina-harija* of Scandinavian origin. The second of these, *harija*, refers to the legendary Harii, the warrior-initiates whose indomitable valor instills terror in their enemies.

possibility, or any other like it, was unacceptable to the princes, so they opted for a different solution. They decided to endow the SDA with a treasury of its own, which, in order to make it independent of all contingencies, should act as an extraordinary reserve that could only be drawn upon in exceptional cases. In practical terms, the treasury consisted of a safety chest in which had been deposited, *in cash*, a considerable amount of gold and silver, to which the eight contributed equally. The Initiates were traditionally calling this reserve fund: *Gatum Aureus*.

By *logistical means* we mean: “all those material elements that contribute to the development of the AI Strategy and ensure its execution.” Hence, the means have naturally varied over the years according to the needs, and cannot be described outside of the historical context. For example, at the time of the foundation, the following were considered as fundamental logistic means: the arrangement of a place free from prying eyes for carrying out the studies of the Hyperborean Wisdom and granting the Hyperborean initiation; and a secret chamber, sufficiently safe for keeping the Legatum Aureus and the trunks with manuscripts in the Enochian language, the *Steganographia*, etc. The initial infrastructure that was counted on for meeting these needs consisted simply of a walled castle, in which secret sectors were constructed to which only the Initiates had access. However, as will be seen later on, these measures proved to be insufficient in the short term due to the Thirty Years’ War and, after this conflict concluded, for various historical reasons, the logistical means were requiring different elements not foreseen in the initial planning of the AI Strategy.

In order to know, with some precision, the fate of the SDA between the seventeenth and twentieth centuries, and to evaluate part of what has been done in terms of financial and logistical means, we will give, at the end of these analyses, a historical outline of the “O” Strategy.

D. Element Analysis (3) = the method must fulfill, among other things, the following main conditions:

1. It has to give, at any time, an *objective* indication of one’s own situation and the enemy’s position.
2. It will determine with absolute certainty when the *HHH guideline “is about to be met.”*

3. It will enable the SDA to *unmistakably recognize the envoy of Wotan*, that invincible Germanic chief on whom the HHH guideline depends.

Course of Action: As a general method, at the time of the foundation, John Dee and Wilhelm adopted one of the seven secret ways of spiritual liberation that the Hyperborean Wisdom teaches. With this way, called “*Strategic Opposition*,” the eight princes of the Dynasty were successfully initiated; it was decided that, henceforth, the SDA would devote itself to cultivating the corresponding *secret technique*, the name (updated) of which is: the *Archemonic Technique*.⁴⁹ In order to comply with the previously mentioned conditions, the following procedure was followed: using ancient Hyperborean techniques (which, however, a Hyperborean Initiate can always know), John Dee designed a *synchronistic state detector*, an instrument that enables one to know, at any moment, one’s own strategic situation and the enemy’s position.⁵⁰

The Detector presents the exterior aspect of a game of chance, which should not be surprising given that numerous “games” such as the *I Ching* of the Chinese, the Inca pallares bean game,⁵¹ the Greco-Roman dice game, Indian chess, Sino-Japanese Go, etc., are all the profane expression of ancient detectors, the esoteric use of which was lost, and which, after an “exoteric fall,” were destined for a “pastime” or an “entertainment.” Current science could only quantify “chance” on the basis of “discrete mathematics,” but without arriving at significant results for having lost the relationship between the metaphysical meaning of number and its ontic reality, i.e., the acausal relationship that exists between the collective archetypes of the human unconscious, of which numbers form a part, and the psychoid collective archetypes that support the forms of the concrete world, reducible mathematics, is unknown. For this reason, the *ignorance of essential principles*, not even counting on the extraordinary science of *cybernetics*, it is

49. Declension of Archemon, a word made up of two Greek terms: αρχή = *principle, sovereignty, dominion, authority* and μόνος = *unity, alone, solitary, only, unique*. The initiation by the *Archemonic Technique* enables one to arrive at a *single principle* of the psyche, i.e., to individuation and the *Vril*.

50. The Detector functions on the basis of an acausal principle that is studied in the Fourth Dissertation.

51. Chuncara

still possible to understand and explain the “functioning” of so simple a “game” as the *I Ching*. This is one of the so-called “divinatory games,” the apparent power of which is that of “detecting” “what is going to happen” in “response” to questions previously formulated by the player. The stalks or coins are thrown *at random, simultaneously* with the formulation of the question. Then the *position* of the stalks (or coins) is *interpreted*, according to the “hexagram” obtained, using an *analogical procedure of symbolic reduction* based on Tradition, in the consultation of “sacred books” or “philosophical manuals” dictated for this purpose by sages who lived millennia ago. Here is where the “fall” of the game is appreciated; because *the synchronistic state detectors do not use regulations*. Any regulation or formal rule is alien to its meaning, contrary to its nature and a sure sign that its use is unknown (either because it was “forgotten,” or because the initiate who designed it did not reveal it).

Lastly, any synchronistic detector is a *tactical element*, such as a radar, an alarm, or a watchtower, designed exclusively for its use in a given strategy. In the detector, the most important thing is its tactical function, to which its construction has been “adjusted,” so that outside of its strategy it is of no use, nor can its “results” be reasonable for anyone. This is what happens with the mentioned games, in truth detectors, which are residues of remote strategies, the key to which was lost millennia ago and with it its meaning, having to add a “regulation” in order to force a meaning that, of course, is no longer the same and never will be.

Wilhelm von Rosenberg ironically called the instrument designed by John Dee as the *Messiah Game*, given that it would make it possible to discover that end time in which the envoy... of the Hyperborean Siddhas,⁵² would manifest himself. But this was not the only reason for such a denomination. In order to prevent the possible fall of the detector into profane hands (which never occurred), it was constructed disguised as a “*model*” nativity scene, so that no one who was not in on the secret could see in it anything but a beautiful representation of the “birth of the baby Jesus.” The detector itself consisted of a board and three pieces that were to be tossed on it. The board

52. It also alludes to the myth of the *Imperial Messiah*, so dear to the Germans. However, every myth is symbolically referred to true facts: “Some day Frederick, the sleeping Emperor, will return in order to restore the Universal Empire.”

was exhibiting on its surface, skillfully drawn, a number of signs and runes, which keep a certain relationship with the megalithic constructions of Europe;⁵³ the pieces were three different polyhedra, also with signs engraved on their faces. As a “*camouflage*,” a “hut” of small dimensions was placed on the board, like a stable, surrounded by many small exquisitely carved figures: the manger with the Christ Child; the Virgin Mother; the Three Wise Men; Joseph the carpenter; various animals such as the horse, the donkey, the goat; some trees and bushes; rock reliefs; etc. Among so many miniatures, no one would have been able to discover the polyhedra, perfectly fitted in some statuettes, nor is it likely that they would have paid attention to the board that was serving as a floor because, no matter how much faith the observer had, he would surely be amazed to see the evangelical meticulousness with which the sacred birth had been depicted.

But let us leave aside for a moment the security measures taken by John Dee and Wilhelm von Rosenberg; let us strip the “Messiah Game” of its accessory elements and ask: in what way could this game fulfill the conditions set forth in Element Analysis (3)? The answer is that the detector was only satisfying (which is really a lot) the first two conditions: it was giving an objective indication of one’s own situation and of the enemy position *at any time, just by tossing the pieces on the board*. And it would also allow one to know the Time in which *the envoy of the Siddhas* would manifest himself, according to the *winning position* of the polyhedra on the board. In effect, although there are no rules for the Messiah Game, the unique position of the pieces that indicates *the aim of the one’s own strategy*, i.e., *the conclusion of the set objectives*, is well determined, thus rendering useless any further action, since it would lack strategic motivation. In the same way, when the strategy that gave rise to it disappears, the meaning of the Game is annulled since, as there is no conflict (*opposition*), there are no strategic positions to detect. That is why a winning position has been determined: in order to indicate that the game is over.

Of course, this naïve affirmation hides the terrible and real consequence that comes from the “winning position,” that is,

53. Such a relationship will become clear in another part of this work, when the origin and significance of the megalithic constructions will be studied.

from the end of the game: that the Time of the messiah has arrived...

It is understood that an instrument of this nature must be handled with extreme care; but surely the unsuspecting reader will be surprised to learn the rigorous manner in which it was operated by the SDA initiates and the time that was elapsing between each "roll." In order to give an idea of the former, it is enough to consider that the board had to be "oriented" geographically and that the initiate who was rolling the polyhedra had to proceed according to a ritual form, in which it was necessary to attend to the position of the body and during which fearsome words in the Enochian language were uttered. Regarding the latter, perhaps the most surprising thing is the fact that the Messiah Game was to be played every thirty-five years, i.e., the "Game," as a detector, could be "consulted" whenever circumstances required it, for example during a crisis or to evaluate alternatives. But, except in cases of extraordinary necessity, the method set by the founders was establishing that the "normal roll" would be performed every thirty-five years, starting in 1589, on a day and time to be determined, each time according to astrological guidelines imposed from the beginning by John Dee.

Thus it turned out that the Messiah Game was operated by the initiates of the SDA only twice a century, on occasions that were of maximum importance to them. As other guidelines given by the founders regarding the incorporation of new members of the Dynasty to the SDA, they were establishing that initiations should be held on fixed dates, every seventeen and a half years, it is understood that each two initiatic ceremonies coincided with the date on which the Messiah Game was operated. It was on these occasions when the ritual was taking on a greater significance because, after the new initiations (if there were candidates for it) the detector was operated in the presence of the totality of the SDA's members. The latter was not occurring in the intermediate initiation ceremonies, where it was possible for only half of the initiates to be present. But during the dual dates, when the initiation ceremonies were held, and then the "normal roll" was performed, the charismatic climax achieved was undoubtedly superior. On those occasions it could be affirmed that the Presence of the Siddhas was constituting a reality perceived by all, although it would be a useless task to attempt to reproduce here,

with mere words, what the initiates were interiorly feeling. We should note, in order to properly appreciate the exclusive and particular character of such an experience, that the majority of the initiates were only able to attend once in their lives a “normal roll” and, in fact, in three hundred years, very few were those who witnessed the operation twice.

On these extraordinary occasions, when exact and meticulous astrological calculations were confirming the chosen moment, a *Berserker*,⁵⁴ i.e., an initiated *Kamerad*, was proceeding to prepare the Messiah Game for its operation. The maximum security measures were adopted for the case, it being normal for the meeting to take place in the deep secret chambers of some impregnable castle. Let us try, however, to witness one of such ceremonies, in which the initiated members of the SDA, all descendants of the eight founding princes, were preparing to “consult” the synchronistic state detector. We can easily imagine them resorting to the Mystery of the Pure Blood, tracing back the charismatic, synchronistic, and acausal sutratma of the Catena Aurea, which unites us, as Hyperborean Viryas, with those who *have seen*.

Let us approach, then, to one of those secret ceremonies of the SDA and let us attentively observe all that was occurring there. For the reader’s amusement, let us only add that we are in a place in northern Germany, at the end of the seventeenth century, under the stone vault of a subterranean room that serves as an initiatic crypt.

The enclosure possesses in the center a circular courtyard, tiled with orange “trapp” basalt slabs, brought from Iceland especially by initiated members of the Dynasty. Completely surrounding this courtyard and forming a celestial circumference, a small channel four inches wide, completely filled with water, gives the impression that a liquid ring has been arranged around it. In order to access the courtyard, one must necessarily cross the stream of water; but as there is no bridge

54. In the SDA, the internal name of which was Einherjar, i.e., “Wotan’s elite,” the initiates were called *Berserkers*, i.e., “Wotan’s select warriors.” The word *Berserker* literally means “bear-like.” On the other hand, the term *Kamerad* is only used at the end of the nineteenth century in the SDA, although later, in the Germanenorden and the Thulegesellschaft, it would become the common denomination of its members, even in the innermost circles. Only Himmler’s *W* brought back the *Berserker* concept, as will be seen further ahead, and tried to bring about the “*Berserker Fury*” in the monk-warriors of the Black Order.

anywhere, the initiates carefully step over it while pronouncing a password.

In the interior of the water ring, as we said, is the courtyard, about thirty feet in diameter. In the center of it, a column of black stone and octagonal base supports, about five feet from the ground, a beautiful reproduction of the Christmas miracle. The "model," which conceals within it the Messiah Game, has been there since many decades ago, when other initiates, ancestors of the present ones, transported it to the newly constructed edifice.

The enclosure where the courtyard with its water ring is located is just below the main hall of an imposing castle. To reach it, it is necessary to penetrate through a secret entrance, concealed in one of the walls of the room, and to descend more than eighty feet down a spiral staircase that seems to be lost in the depths of the earth. The last step enables one to enter a gallery that surrounds eight enormous pointed arch columns, which are arranged around the initiatic enclosure and undoubtedly support part of the castle's structure. It is therefore possible to walk through the gallery and penetrate the enclosure from different angles, just by crossing any of the eight pointed arches, the height of which is easily three times the height of the tallest man present.

A short distance up the stairs, and on both sides of the columns, oil torches provided a more-than-acceptable illumination for those mysterious persons who, curiously enough, were accustomed to face fiery demons, whose false, material, and thermal light is a thousand times stronger than the brightest sun in the sky.

We have seen that by crossing any of the arches it is possible to enter the initiatic enclosure. This consists of a large octagonal room of about sixty feet between opposing columns, i.e., twice the diameter of the central courtyard. The furnishings here are sparse, contrasting enormously with the sumptuousness of the upper rooms of the castle, for it consists only of two trunks at the foot of each column and a small table in front of each trunk.

Let us now prepare ourselves to witness the arrival of the initiates.

Fifteen persons are those who descend the winding and stony staircase. They do it one by one, respecting the reduced dimensions of the steps; and, although the previously lit

torches offer abundant light, the man who leads the way carries in his hands a Roman lamp with two lighted asbestos wicks, of the so-called "oil lamps." The first to arrive at the gallery, the man with the lamp, took a right turn and began to walk at a good pace until stopping in front of one of the arches. Those who preceded him continued walking in the same direction, although some stopped in front of the arches through which they were assigned to enter the initiatic enclosure.

These persons are dressed in such a way that one might say is more appropriate to the lavishness of a French court than to that secret and solitary setting. In reality, a few minutes before, they were all in a situation more in keeping with their attire, for they were just dining in the upper room of the castle, surrounded by the comforts and luxuries that that epoch had reserved for the high dignities of the nobility and the clergy. Anyone who had witnessed the previous feast would no doubt hastily draw the conclusion that the travelers constituted a familial group in no way different from those who, back then, were engaged in the noble tasks of their class and condition: eating, drinking, making war, managing the patrimony of the land or the goods of the Church, etc. Yes; those who had dined in the castle were perfectly corresponding with that frivolous image; and it should not be surprising that they succeeded in deceiving any observer. For in reality, as we have already seen, these persons were the initiated members of the Dynasty, custodians of the Hyperborean Wisdom, and executors of the AI Strategy. The safety of their mission was to a great extent depending on the simulated adaptation and integration to the customs of the time. Let us review the fifteen relatives who dined merrily that evening, and ask ourselves: what would become of them if anyone suspected their secret activities? But we have already had the opportunity to see how zealously the founders took care to avoid future evils, and those present were magnificently up to the task. In the foreground were two representatives of the Church: an archbishop from an important city on the Rhine and a bishop coming from Upper Bavaria. The only two dames were contrasting with each other in spite of their kinship: the older one was the Castellana, a widowed countess who in her youth was renowned for her beauty, but who was now showing no less resolution, energy, and majesty, to such an extent that her gestures alone were commanding a particular respect from all those present. The

second dame, the second cousin of the Castellana, was a young and beautiful princess, of so cheerful and carefree a character that it would be quite impossible to even suspect her participation in the most ingenuous of secrets. She had arrived at the castle accompanied by her husband, a young prince, who was also her cousin and an initiated "Berserker," as well as a Lord of a small land east of Mecklenburg. The remaining ten knights, whose ages were ranging from twenty to sixty, were all Territorial Seigniors and, like the others present, vassals of the Emperor. Among the ten were a prince-electoral, a duke, two counts, and two margraves. It is understandable that it was not an easy task for these personalities to meet without arousing surprise or curiosity; and here, undoubtedly, the success of the kinship was evident, which in itself was ruling out many questions. However, there were countless difficulties easy to imagine: several of the initiates were coming from distant states and had to prepare their journeys in advance, sending messengers, as was then the custom, to the numerous territories that they had to cross in order to warn their Seigniors. There was no way to keep the journey secret; although this disadvantage was compensated for by the well-thought-out excuses given as the reason for the journey. The need for it had been planned or "created" in seventeen years. Another problem, for example, was the fact that, while one of those present was a great archbishop, another of them, the elector-prince, was a Protestant who was passing for a declared enemy of the Church; in the same ambiguous situation were the other Initiates by reason of their different religious confessions. These were exoteric differences with tactical aims, of course; but if the identity of all the participants in such a "familial" meeting was known, it could easily have turned out to be suspicious. In order to avoid this, several of the nobles were declaring destinations farther away than the initiatic castle, so that in the course of their route they were happening upon it "by chance," stopping there as long as it was necessary to perform the ritual, and then immediately departing.

But let us return to the crypt. As soon as the fifteen initiates crossed the pointed arches, they found themselves in the already described vaulted enclosure, within sight of the initiatic courtyard with its ring of water. However, none of them seemed to pay much attention to so strange an environment, perhaps because of knowing it beforehand; and, instead, each

one went resolutely toward the trunk that was corresponding to him. Each trunk was containing three types of things: a piece of stone cut from the same mountain as the other fifteen; a complete set of warrior garb; and two weapons: a modern Germanic sword, with a rich hilt and fearsome blade; a double-edged axe, which would seem as ancient as those used millennia ago by the Cretan warriors in their particular labyrinth strategy. Next to these weapons was a shield of three convex sides, skillfully constructed with a riveted steel frame, which was completely covered with a thick and hard leather. At the exterior center of the sixteen shields was engraved the same ancient and forbidden Hyperborean Sign of the Lords of Venus. All these objects were quickly placed on the tables set up for that purpose in front of the trunks, and then the Initiates began to change their clothes. For a moment we will leave the initiates in the crypt and we will make a parenthesis in order to analyze certain theoretical questions, in the light of the Hyperborean Wisdom.

The Einherjar Order, or SDA, always performed the rites established by its founders, John Dee and Wilhelm von Rosenberg. In order to comprehend the nature of such rites and, fundamentally, the objective that they were pursuing, it would be necessary to be a Hyperborean Initiate... or to know the “Fundamental Thesis of the Hyperborean Wisdom.” This thesis will be exposed in the “Fourth Dissertation”; and we do not doubt, upon learning it, that many of the difficulties arisen during the reading of the *Secret History of the Thulegesellschaft* will be definitively overcome. But we now find ourselves in a secret crypt of the SDA, about to witness a strange spectacle and without yet possessing the keys for interpreting it. However, it will be useful to remember the ceremony performed by John Dee in the Prague Tower, for initiating the Emperor Rudolf II and the noble Wilhelm von Rosenberg, and some concepts of the Hyperborean Wisdom that we have previously explained. With said elements and a certain internal symbolism of the SDA that we will explain below, we will be able, if not to penetrate into the depths of the Mystery, at least to glimpse the presence of the Mystery itself, toward which the rituals were pointing.

We have already spoken of the *Viryas*, semi-divine men who possess in their blood the inheritance of the Divine Hyperboreans called, to simplify, “Minne.” We also said that the

Viryas could be “lost” or “awakened” and we defined the “lost Virya” as one who has “lost the Origin” thanks to a “blood confusion.” Blood confusion provokes a psychological state of great misdirection, which is technically called “strategic confusion.” Consequently, the “blood purification” that facilitates the Hyperborean Wisdom, by seven secret ways, produces a “strategic reorientation” in the lost Virya, enabling him to undertake (or re-start) the return to the Origin and the abandonment of the infernal world of matter. The “lost Virya,” as we have already said, is in an abject state of material enchainment that forces him to be subjected to the laws of Karma, to periodically reincarnate and live, or re-live, an eternal and miserable comedy marked by the sinister illusion of pain, of fear, and of death. In the “Great Deception” of life, the lost Virya can occupy any position and even “collaborate” with the “evolutive” and “progressive” “Plan” of Jehovah Satan, or with His “system of social control” called, also to simplify, “Synarchy.” It is not convenient to expand on the *type* of the “lost Virya” because it does not present a great mystery, given that it is possible to concretely observe it in most of the good persons who inhabit the different countries of Earth.

Instead, the “awakened Virya” deserves our greatest respect. He is the one who has put himself on “alert” when ascertaining his “disorientation” and, with firm decisiveness, intrepidity and warlike valor, has begun to seek the Origin in order to, just now, undertake his return. This decision, of course, will not be respected by the enemy who will try by all the infinite means at its disposal to confuse the daring defiant one, seeking to prevent him from discovering the *way to return*, inducing him, by illusion and deception, to break his “alertness.” That is why the awakened Virya can only succeed if he acts *in the framework of a Hyperborean Strategy*. To do so, he must completely assume his warrior status, seek in the memory contained *in* the blood the primordial potencies of the immortal Spirit, the strength of the Vril, and, in a gnostic outburst, recover the *essential hostility* toward the material world of the Demiurge, experience the *Berserker Fury*. Then, already the owner of an unbreakable will, inspired by the Hyperborean Wisdom of which he is the bearer by the inheritance from the Ancestral Siddhas, he will deploy his *own Strategy* conceived *to oppose the enemy strategy* and win. From there on, he will only carry out *strategic movements, tactical actions*, aimed at *not*

losing sight of the Origin while taking the *steps of the return*. And, in the midst of the heat of combat, or what is worse, while waiting for it, when the enemy forces, masked in the illusory forms of this and other worlds, reveal their diabolical threat, the awakened Virya coldly seeks *to gain time*, however minimal it may be, *to move in the direction of the Origin*. The right to have *time at one's own* disposal, perhaps as fleeting as the smallest instant, must be won in a fierce struggle against the demonic legions of the Demiurge, against the poetic spell exerted by the sensible world (with its thousand possible concupiscences) that we call the Great Deception, in short, against the Will of The One. It seems an impossible task. The Hyperborean Wisdom, and even the Gnostic Tradition, affirm that it is possible. But then, how to do it?

The answer to this question is dealt with in the seven secret ways of the Hyperborean Wisdom. And, we already said at the beginning of this “course of action” that the method of John Dee and, consequently, the rituals of the SDA, were based on one of such ways called “*Strategic Opposition*” and its corresponding secret technique (*Archemonic Technique*). Therefore, it is possible that the reader, if he heeds all that has been said so far about the lost Viryas and listens to the voice of his blood, may find the ceremony that he *is* about to witness *significant*. It is part of the answer that the Hyperborean Wisdom gives to the question posed earlier; but *neither we nor anyone* else would attempt to answer that question *directly*. Precisely, the ritual constitutes an analogical response, the only one possible during the Kaly Yuga, and it will depend on the reader's capacity for semiotic induction, the “knowledge” that can be attained from a mere description.

We have made it clear that, even by ignoring the Fundamental Thesis of the Hyperborean Wisdom, it is possible that the ritual of the SDA may be of significance to us if we analogically relate it to “the quest of the awakened Virya,” i.e., to his own strategy. But let us recall that the initiates of the SDA are awakened Viryas who have been entrusted with a mission to be fulfilled as they attain their blood purification; i.e., they have assembled their own personal strategy with a racial, collective, and totalizing strategy. This facilitates things because, in the framework of such a strategy, it is quite easy to perceive the Siddha who illuminates the charismatic center of the Order, or of the “closed circle,” and to be guided by Him to the

Origin, achieving the mutation and also transforming himself into a Siddha, into a Divine Hyperborean immortal. But in this case, honor prevents the Virya from abandoning the totalizing strategy even though his own strategy has concluded. He then decides to continue by operating in the world for the good of the Race, preparing the conditions so that the Ancient Hyperborean Guides of humanity can return. This is the only difference that must be taken into account when observing the Viryas of the SDA: that an awakened Virya, upon concluding his own strategy and reaching the Vrill, immediately abandons the infernal regions; on the other hand, an initiate of the SDA, whether an awakened Virya or an immortal Siddha, has to continue the combat for a while longer in favor of his lost comrades.

It is now useful to make an elementary introduction to the internal symbology of the SDA in order to further facilitate the interpretation of the ceremony.

For the *Berserker*, Initiates of the *Einherjar* or SDA, the "world" in which daily life occurs is simply a "battlefield," an *arena* plagued by mortal enemies whom one must combat without truce, since they "cut off the way back," "obstruct the withdrawal" and intend to "reduce us to the most vile slavery," which is "the submission of the immortal Spirit to matter," its "enchainment to the Evolutive Plan of the Demiurge and His court of demons." The "World" is then, for the Berserkers: *the Valplads*.⁵⁵ Is there not, then, a place where the warrior can rest his weapons, a place in which for even a second it is possible to distract his attention from the enemy and set it on the Golden Origin? Neither can such a place nor such a time exist by themselves, but they can be strategically created. In the *Valplads* there is no other possibility but to combat or to surrender, an alternative, this latter one, that implies sinking oneself into the worst degree of the lost Virya's idiocy. But, the one who fights, always has the possibility of "liberating" a *Plaza* and making himself strong in it. For this purpose, the way of "Strategic Opposition" teaches the "Archemonic Technique," which includes the important concept of the "fence function." According to the Hyperborean Wisdom, which says "every closed curve divides its plane into two parts." A closed curve

55. *Valplads*: In Norse mythology and in the *Edda*, it is the battlefield where Wotan chooses those who fall fighting for honor or truth. The SDA, based on Hyperborean Wisdom, was extending the concept of *Valplads* to the whole "world."

can have any form, squared, circular, elliptical, etc., but it always presents the qualitative fact that it divides its plane into two parts. The geometrical property expressed by this theorem, easily intuited, is important to us because the “closed curve” is the most abstract case of the “fence” and an evident starting point for the definition of the concept.

Man applies “the principle of the fence” when he makes the formal differentiation and distinguishes between “an outside” and “an inside”; but such a property is not exclusively human; other animals also possess it, as ethology has been able to demonstrate. Animals that present a “notion of territory” also make use of the “fence function” in order to delimit their “living space” or Lebensraum. But ethology, starting from the scientific premises of Darwinian evolutionism, fails to interpret the datum obtained from empirical observation, and only manages to define a “territory function” common to “territorial animals,” i.e., those that delimit an area as their own and defend it from any enemy intrusion. This is seeing only a part of the problem and, surely, ethology would advance much more if it uses the concept of the “fence function” that the Hyperborean Wisdom teaches.

The Archemonic Technique enables every awakened Virya to apply the fence function in the ambit of the *Valplads* and “divide the space into two parts.” The “interior” part of the fence or “Archemon”⁵⁶ will be immediately occupied by the Virya who will have thus *strategically* created the place from where *he will look* toward the Origin. *He will create* the necessary *time of his own* from the Archemon by means of *Strategic Opposition*, a technique that requires the *definition of a place, a point, etc., in the Valplads*, i.e., “outside” of the Archemon. This exterior “point” usually consists, for practical purposes, of a stone, just as John Dee operated in the Tower of Prague, performing the “opposition” with the stone mirror of Princess Papan. Each one of the Berserkers was using, as we saw inside the trunk, an unpolished stone, cut from the same mountain. Against these stones they were performing the Strategic Opposition that was enabling them to “desynchronize” them-

56. The “Archemonic Technique” is the adaptation to modern culture of a very ancient Hyperborean technique based on the “fence function.” All the mandalic systems, of the various post-Atlantean cultures, derive from this technique and it can be affirmed that the Archemon and the fence function are the true fundamentals of the mandala.

selves from the time of the *Valplads*, i.e., from the “time of the world” and to create their own time with which *to gain steps toward the center*.⁵⁷

We should now stop for a moment and make a very brief summary, which will allow us to synthesize some conclusions.

The principal objective of the awakened Virya is to orient himself toward the Center-Origin. Upon him acts a powerful enemy Strategy, the aim of which is to keep him in confusion. The enemy Strategy dominates space and time. “Space” “is” of the enemy because in the totality of the material universe exists a pantheistic diffusion of the Demiurge and his devic Hierarchy. “Time” “is” of the enemy because “time is the constant flow of the Demiurge’s consciousness.” The human body occupies space and contains matter of pantheistic manifestation. It also possesses temporal biological functions (“biological clocks”) synchronized with other solar and lunar rhythms, apart from the fact that the principal function, “consciousness,” occurs in time. Therefore, if the immortal Spirit, which seeks to liberate itself from material chains, excessively depends on the physical body, it will never be able to find the exit, will never succeed in “orienting itself.” The physical body, by itself, constitutes the heaviest chain if it only “forms part” of the material universe, since it then binds us to the space and time of the enemy.

But the physical body is also a microcosm, a reflected expression of the macrocosm of the Demiurge, and as such possesses the possibility of creating its own space and its own time. But this possibility can only be concretized if first the condition of microcosm is actualized, and for that it is necessary *to isolate* the physical body from the remaining material order. This signifies, among other things, attaining physical immortality as a consequence of the independence with which the vital cycle of the microcosm develops with respect to the macrocosm. To make the physical body, which until now was only “a part of the world,” an autonomous microcosm, independent of pantheistic space and Karmic time, is the possibility that the Hyperborean Wisdom with its seven secret ways of spiritual liberation offers.

57. The theory of time held by the Hyperborean Wisdom will be expounded in the Fourth Dissertation.

But “immortalizing oneself in a physical body” does not represent any solution to the problem of spiritual enchainment. This “conquest” is only a step in the search for “orientation”; the only, unwavering and irreplaceable goal of the Virya is to reach the Origin and “abandon” the material order.

“Reaching the origin,” let us not forget, means “conquering the Vril,” being “pure possibility,” and implies the certain abandonment of the material hell, the sublime instant in which the physical body, or microcosm, now immortal, surrenders itself, for its fusion with the macrocosm.

The physical body, then, must be given its just valuation as an instrument of extreme usefulness for the strategic aims of the captive spirit in its march toward the Origin. For this, it is necessary for the physical body to actualize its spatio-temporal potentialities and transmute itself into microcosms. The “Way of Strategic Opposition” that the SDA was following makes such a transmutation possible because the “Archemonic Technique” isolates the physical body from the material universe, enabling it to “gain a space of its own” without a pantheistic impregnation. Within that space, which the SDA was calling “Plaza,” the technique of “Strategic Opposition” makes it possible to “create” a time of one’s own, that is, to make the “consciousness of the microcosm” independent of the “consciousness of the macrocosm” or time of the world. Here we can consider the summary concluded.

To go a little deeper, now, into the Archemonic Technique we must again take up the “fence” concept. We have previously said that the fence function appears as a “law of nature”; and we also affirm that the *principle of the fence* constitutes a structure of the human mind, i.e., a collective archetype. This duplication should not surprise us. If we accept the Hermetic principle of equivalence between macrocosm and microcosm, we will find it evident that *all* the laws of the macrocosm are reflected in analogous laws of the microcosm and *vice-versa*. But this correspondence between macro and microcosm is far from being a mere passive reflection between structures. Man, by *discovering* and *formulating* laws, disequilibrates that relationship and assumes a prominent role. As a consequence of this dominant attitude, now appears, between the macrocosm from the microcosm, a cultural model elaborated by a cultural subject based on principles and concepts. It is this “cultural model” that is mainly responsible for the deformed vision that

he has of himself and of the world, given that it “interposes” itself between the macrocosm and the microcosm. The cultural model contains the totality of the collective knowledge of the world (the “laws of nature” being in first place) and, since man is its administrator, a “problem of the cultural premises’ pre-eminence” is posed. In order to duly clarify this problem, we will first elaborate on some concepts of which we will very soon have to avail ourselves.

Above all, it will be useful to know what we mean by “law of nature.” Without entering into complications we can affirm that “a law of nature is the mathematical quantification of a significant relationship between aspects or magnitudes of a phenomenon.” Let us clarify this definition. Given a phenomenon, it is possible that by observation and empirical experimentation we can come to differentiate certain “aspects” of it. If from among the various aspects that stand out, some of them turn out to be “significantly related to each other,” and if this relationship possesses statistical probability, i.e., it is repeated a large number of times or is permanent, then a “law of nature” can be enunciated. For this it is necessary that the “aspects” of the phenomenon can be reduced to magnitudes in such a way that the “significant relationship” is reduced to a “relationship between magnitudes,” that is, to a mathematical function. The “laws” of physics have been deduced in a similar way.

The concept of a “law of nature” that we have exposed is modern and aims at “controlling” the phenomenon rather than explaining it, following the current tendency that subordinates the scientific to the technological. Thus we have phenomena “ruled” by *eminent* laws to which we not only accept as determinants but indissolubly incorporate them into the phenomenon itself, forgetting, or simply ignoring, that we are dealing with rational quantifications. It is what happens, for example, when we notice the phenomenon of an object that falls and we affirm that such a thing has occurred because “the law of gravity acted.” Here the “law of gravity” is eminent and, although “we know that other laws exist,” those that “also intervene but with less intensity,” we blindly believe that the falling object *obeys* the Newtonian law and that this “law of nature” has been the *cause* of its displacement. However, the concrete fact is that the phenomenon *does not obey any eminent law*. The phenomenon simply *occurs* and there is nothing in it

that intentionally points to a law of nature, let alone an eminent law. The phenomenon is an inseparable part of a totality that we call “reality,” or “the world,” and that includes, in that capacity, *all* phenomena, those that have already occurred and those that will occur. That is why in reality phenomena simply *occur*, succeeding, perhaps, some that have already occurred, or simultaneously with others similar to it. The phenomenon is only a part of that “phenomenic reality” that never loses its character of totality: of a reality that is *not* expressed in terms of cause and effect to sustain the phenomenon; in short, of a reality in which the phenomenon *takes place* independently of whether or not its occurrence is significant for an observer and complies with eminent laws.

Before approaching the problem of the “pre-eminence of cultural premises” in the rational evaluation of a phenomenon, it is convenient to strip it of any possibility that separates it from purely mechanical or evolutive determination, according to the “natural order.” For this purpose we will establish, after a brief analysis, the difference between phenomena of “first” or “second” degree of determination, an indispensable clarification given that “eminent laws” always correspond to phenomena of the first degree.

For the Gnostic, “the world” that surrounds us is nothing more than the ordering of matter effectuated by the Demiurge in a beginning and to which we perceive in its temporal actuality. The Hyperborean Wisdom, the mother of gnostic thought, goes further by affirming that space, and all that it contains, is constituted by multiple associations of a single element called “psychophysical quantum of energy” or UEVAC unit of energy. These UEVAC, which are true archetypal atoms, *not* conformers to or structurers of form, each possess an *indiscernible point* through which the pantheistic diffusion of the Demiurge is realized. That is to say that, thanks to a point system of poly-dimensional contact, the presence of the Demiurge is made effective in every ponderable portion of matter, whatever its quality may be. This universal penetration, when being verified by persons in different degrees of confusion, has led to the erroneous belief that “matter” is the very substance of the Demiurge. Such are the vulgar conceptions of pantheistic systems or of those who allude to a world Spirit or “anima mundi,” etc. In reality, matter has been “ordered” by the Demiurge and “impulsed” toward a *legal* development *in time*

from which evolutive force not even the smallest particle escapes (and in which the “human body” participates, of course).

We have made this synthetic exposition of “Hyperborean Physics” because we need to distinguish two degrees of determinism. The world, as we have just described it, unfolds mechanically, oriented toward a finality; this is the *first degree* of determinism. In other words: there is a Plan to which guidelines are adjusted, and to which designs the “order” of the world tends; the matter left to the mechanics of said “order” is *determined in the first degree*. But, as said Plan is sustained by the Will of the Demiurge, and His Presence is effective in every portion of matter, as we saw, it could occur that *He, abnormally*, influences *in another way* some portion of reality, either *to teleologically modify His plan* or *to semiotically express His intention*, or for *strategic motives*; in this case we are before the *second degree* of determinism.

We can now distinguish between a *phenomenon of the first degree* and a *phenomenon of the second degree* according to the degree of determination that its manifestation involves. It should be well understood that this distinction emphasizes *the different* manners in which the Demiurge can act on *the same* phenomenon. For example, in the phenomenon of a flowerpot falling from a balcony to the sidewalk, we cannot see anything else but a determination of the first degree; we say: “the law of gravity acted.” But, if said flowerpot fell on the head of the awakened Virya, we can suppose a second determination or, with rigor, a “second intention” we say: “the Will of the Enemy acted.”

In general, every phenomenon is susceptible to manifest itself in a first and second degree of determination. Taking this into account, we will agree on the following: unless otherwise indicated, by “phenomenon,” that determination of which is purely mechanical, i.e., of the first degree, will be understood; otherwise it will be clarified, “second degree.”

All that remains, now that we distinguish between “the two degrees of the phenomenon,” is to clarify the affirmation that we made at the beginning of this analysis, that every law of nature, including those eminent, describes the causal behavior of phenomena of the first degree of determination. It is easy to understand and accept this since when a determination of second degree intervenes in a phenomenon, the natural sense of mechanical enchainment has been temporarily alienated in

favor of an irresistible Will. In that case the phenomenon will no longer be “natural” even if it appears to be, but will be endowed with a superimposed intentionality of clear *malicious character* (for the Virya).

On the other hand, the phenomenon of the first degree always manifests itself *complete in its functionality*, which is a direct expression of its essence, and to which it will always be possible to mathematically reduce to an infinite number of “laws of nature.” When the phenomenon of the first degree is especially detected because of *one* law of nature, which is eminent to us, since *it highlights a certain* interesting aspect, it is evident that one is not dealing with the *complete* phenomenon but with said “aspect” of it. In such a case, one must accept the sad fact that only an Illusion will be perceived from the phenomenon. Sensorially mutilated, gnoseologically deformed, epistemologically masked, it should not be surprising that the Indo-Aryans qualified the ordinary perception of a phenomenon of the first degree as *Maya*, Illusion.

We will now pose a question, the answer to which will enable us to face the problem of the “preeminence of cultural premises,” based on the most recent conclusions: “if every phenomenon of the first degree necessarily appears complete (For example: at 6 a.m. ‘the sun rises’),” what is the specific reason that its apprehension through the intermediary of the “scientific or cultural model” prevents dealing with the phenomenon in its entirety, and circumscribes around partial aspects of it? (for example when we say: “the terrestrial rotation is the *cause* that has produced the *effect* that the sun has become visible at 6 a.m. on the Eastern horizon.”) In this latest example, it is evident that by explaining the phenomenon through an “eminent law,” one does no more than refer to certain partial aspects (the “terrestrial rotation”), leaving aside—not seeing—the phenomenon itself (“the Sun”). The answer to the posed question leads us to touch upon a fundamental principle of structural epistemological theory: *the relationship that is noticed between aspects of a phenomenon, mathematically quantifiable as a “law of nature,” originates in the preeminence of cultural premises from which reason modifies the perception of the phenomenon itself.*

When we make a “scientific” observation of a phenomenon, the rational functions become preeminent to any perception, “highlighting” those interesting or useful aspects with emi-

nence and “tarnishing” the rest (of the phenomenon). In this way, reason operates, as if masking the phenomenon, previously torn from the totality of the real, and presenting it with a “reasonable” and always comprehensible appearance in the ambit of human culture. Of course, no one cares that the phenomena are, from there, hidden behind their reasonable appearance; not if it is possible to make use of them, control them, harness their energy, and direct their forces. After all, a scientific-technological civilization is built *on* phenomena and even *against* them; what does it matter if a rational vision of the world cuts out the perceived phenomena and confronts us with a *cultural reality*, the more artificial the more blind we are? What does it matter, I repeat, when such gnoseological blindness is the price to be paid to enjoy the infinite variants that, in terms of enjoyment and comfort, scientific civilization offers? Perhaps some danger lurks that we cannot technically avert, we who have eliminated many and ancient illnesses, who have prolonged human life and created an urban habitat with a never-before-seen luxury?

The danger exists, it is real, and threatens all those members of humanity who possess Hyperborean ancestors; the Hyperborean Wisdom calls it *psychic phagocytation*. It is a psychic kind of danger and of a transcendent order that consists in the metaphysical annihilation of the consciousness, a possibility that can concretize in this or in another world, and at any time. The destruction of the consciousness happens by *demiurgic phagocytation*, i.e., by assimilation of the *conscious subject* to the substance of Jehovah Satan. When such a catastrophe occurs, all possibility of transmutation and return to the Origin is completely lost. We have already spoken about the dramatic alternative that the Virya must face and of which we will return to speak at length in the Second Part; however, it is worth repeating that *confusion* is the principal impediment to the transmutation of the Virya into an immortal Siddha, and, the gnoseological blindness that we were mentioning before, a product of our modern rationalistic mentality, contributes to the permanent confusion. We live according to the standards of Western “Culture,” which is materialistic, rationalistic, scientific-technological, and amoral; thinking starts from preeminent cultural premises and conditions the vision of the world, turning it into pure appearance, without being noticed or having any idea of it. Culture, then, maintains us in

confusion and prevents us from orienting ourselves and marching toward the center of psychic re-integration, after mutating into Siddhas. Is it by chance that such a thing happens? We have said it many times: culture is a strategic weapon, skillfully used by those who desire the perdition of the Hyperborean Inheritance.

When the critique of the modern urban culture of the “Christian Occident” is carried out, the “evils” that this provokes in some individuals are usually detailed: alienation; dehumanization; slavery to consumption; depressive neurosis and its reaction: dependence on various vices, from narcosis to the perversion of sex; merciless competition, motivated by dark sentiments of greed and ambition of power; etc. The list is endless, but all the charges deliberately omit what is essential, emphasizing evils “external” to the Soul of man, originated in “imperfections of society.” As a complement to this fallacy, it is argued that the solution, the remedy to all evils, is “the perfectionment of society,” its “evolution” toward more just, more humane forms of organization, etc. The omission lies in that the evil, the only evil, *is not external* to man, comes not from the world, but rather is rooted in his interior, in the structure of a mind conditioned by the preeminence of the cultural premises that sustain reasoning and that deform his vision of reality. Present-day society, on the other hand, has managed to Judaize the current man in such a way that has, in turn, transformed him—a miracle that genetic-biology cannot even dream—into a miserable Jew, greedy for profit, content to apply compound interest and happy to inhabit a World that glorifies usury. Needless to say that this society, with its millions of biological and psychological Jews, is for the Hyperborean Wisdom only an evil nightmare, which will be definitively swept away by the *Wildes Heer* at the end of the Kaly Yuga.

We have made manifest the fact that a “law of nature” originates in certain relationships that rational judgment establishes between significant aspects of phenomena. Our purpose is to make it clear that although such aspects truly belong to the phenomenon, the relationship that gave rise to the eminent law has been created by reason and can in no way be attributed to the phenomenon itself. Reason, supported by pre-eminent cultural premises, utilizes the world as a *projective* or *representational model* in such a way that any phenomenon expresses a *correspondence* with an equivalent intellectual con-

ception. In this way man makes use of rational concepts of the phenomenon that keep a weak connection with the phenomenon itself, with its truth.

When carrying out reasoning and analysis on the basis of such concepts, error is added and the result cannot be other than the gradual immersion to unreality and confusion. This effect is sought by the enemy, as we have said. We will later see how the Hyperborean Wisdom teaches to avoid it.

In previously mentioning the Hermetic Principle, we said that all the laws of the macrocosm were being reflected in equivalent laws of the microcosm. But “the laws of nature” of the macrocosm are but representations of a mathematical model originated in the human mind, i.e., in the microcosm, as we have analyzed. In the process that gives rise to the “scientific idea” of a phenomenon, elements from two principal sources concur: the “mathematical principles” and the “preeminent cultural premises.” The “mathematical principles” are archetypal, they come from inherited psycho-biological structures (when we “learn mathematics,” e.g., we only consciously actualize a finite number of formal systems that belong to the ambit of culture, but the “mathematical principles” are not really “learned” but “discovered” because they constitute basic matrices of the structure of the brain). The “preeminent cultural premises” arise from the *totality* of cultural elements, learned throughout life, which act as conscious or unconscious content of memories and registers and to which reason turns in order to formulate judgments (by “reason,” here we mean an *operator* that relates different elements according to a certain “logic.” The “operator” is *hereditary*; the “logic,” i.e., the *agreed mode* of operating, is *cultural*: it depends on social, ethical, moral, etc., rules and principles, and is closely linked to one’s own linguistic structure, to one’s native language).

The distinction that we have made between “mathematical principles” and “preeminent cultural premises,” as two principal sources that intervene in the mental act of formulating a “law of nature,” will allow us to expose one of the most effective tactics that the Demiurge uses to keep the Viryas in confusion and the manner that the Loyal Siddhas try to counteract it, charismatically inducing them to discover and apply the “law of the fence.” That is why we have insisted so much on the analysis: because we are before one of the most important

principles of the Hyperborean Wisdom and, also, one of the enemy's best-kept secrets.

When one knows the principle that says "for the Synarchy, culture is a strategic weapon," it is usually thought that it refers to "culture" as something "external," proper to man's conduct in society and the influence that it exerts on him. This error comes from an incorrect comprehension of the Synarchy (which is supposed to be a mere "political organization") and of the role that it plays in the Plan of the terrestrial Demiurge Jehovah Satan. The truth is that the Virya procures to orient himself toward the Origin and does not succeed because of the state of confusion in which he finds himself; culture contributes to maintain him in this state as a strategic enemy weapon, but if this attack came *only* from the exterior, i.e., from society, it would be enough to distance himself from it, to become a hermit, in order to neutralize its effects. However, it is sufficiently proven that solitude is not enough to avoid confusion, and that, on the contrary, this usually increases in the most hermetic retreat, being very probable that, by that path, reason is lost long before the Origin is found. The *interior* cultural elements are those that confuse, divert, and accompany the Virya at all times. That is why the awakened ego must *first* be liberated from the obstacle that the cultural elements impose if it intends to bridge the distance that separates it from the Vril.

An ego stripped of every moral, of every dogma, indifferent to the deceptions of the world but open to the memory of blood, will be able to gallantly march toward the Origin and no force in the universe will be capable of stopping it.

It is a beautiful image, that of the man who intrepidly advances, enveloped in warlike furor, without the Demons able to stop him. We will always present it; but, it will be asked, how is it possible to acquire such a degree of purity? Because the normal state of man, at this stage of the Kaly Yuga, is confusion. We will now explain, in response to so sensible a question, the tactics of the Loyal Siddhas to *orient* the Viryas and neutralize the effect of synarchic Culture.

In the lost Virya, the ego is subject to reason. It is the rudder that guides the course of his thoughts from which it would not deviate for anything in the world; outside of reason are fear and madness. But reason operates from cultural elements; it has already been seen in what manner the "preeminent cul-

tural premises” participate in the formulation of a “law of nature.” So the yoke that the Enemy has tightened around the ego is formidable. One could say, in a figurative sense, that the ego is a *prisoner* of reason and its allies, the cultural premises, and all would comprehend the meaning of this figure. This is because a clear analogical correspondence exists between the ego, in the lost Virya, and the concept of “captivity.” For this reason we will next expound an *allegory*, in which the highlighted correspondence will become evident, which will later allow us to comprehend the secret Strategy that the Loyal Sidhas practice in order to counteract *the cultural weapon* of the Synarchy.

Let us begin presenting the allegory by fixing the attention on a man, to whom they have taken prisoner and condemned, in an unappealable manner, to perpetual reclusion. He is unaware of this sentence, as well as of any information coming from the exterior world subsequent to his capture, for it has been decided to keep him indefinitely incommunicado. For it, he has been locked away in an inaccessible tower that is surrounded by walls, abysses, and moats, and where any attempt to escape is apparently impossible. A garrison of enemy soldiers, to whom it is not possible to address without receiving some punishment, are permanently in charge of keeping watch on the tower; they are merciless and cruel, but terribly efficient and loyal: do not even think of buying off or deceiving them. Under these conditions, any hope that the prisoner will ever regain his freedom does not seem to exist. And, nevertheless, the real situation is quite another. While *outward* from the Tower the exit is cut off by walls, moats, and soldiers, *from within* it is possible to go directly to the exterior, without stumbling upon any obstacle. How? By means of *a secret exit* to which access is cleverly concealed in the floor of the cell. Naturally, the prisoner is unaware of the existence of this passageway, nor do his jailers know of it.

Let us now suppose that, either because *he has been convinced* that it is impossible to escape, or because he is *unaware* of his captive status, or for any other reason, the prisoner shows no predisposition for escape: he manifests neither valor nor daring and, of course, does not seek the secret exit; he has simply resigned himself to his precarious situation. Undoubtedly his worst enemy is his own negative attitude since, keeping the desire to escape alive, or even, if he experienced the

nostalgia for the lost freedom, he would be looking around in his cell where, at least, a one-in-a-million possibility exists of finding the secret exit *by chance*. But that is not the way it is and the prisoner, in *his confusion*, has adopted a placid conduct that, as the months and years go by, becomes more and more pusillanimous and idiotic.

Having surrendered to his fate, the captive could only hope for an exterior help, which can only consist in the *revelation of the secret exit*. But it is not so simple to expose the problem, since the prisoner does not want it or does not know that he can escape, as we have said. Two things must then be fulfilled: 1°) Getting him to come to terms with his condition as a prisoner, as a person to whom his freedom they have *taken away*, and, as far as possible, *remember the golden days* when there were neither cells nor chains. It is necessary that he become aware of his miserable situation and ardently desires to get out, previously to: 2°) Revealing to him the existence of the *only possibility of escape*. Because it would be enough, now that the prisoner desires to escape, just *as long as he hears of the existence* of the secret exit; he will seek and find it by himself.

Posed like this, the problem seems very difficult to solve: it is necessary to wake him up, to *awaken him* from his lethargy, *orient him*, and then *reveal to him* the secret. That is why it is time to ask ourselves: is there anyone willing to help the miserable prisoner? And if there were, how would he manage to fulfill the two conditions of the problem?

We must declare that, fortunately, there are other persons who love and procure help for the prisoner. They are those who share his ethnicity and inhabit a country very, very far away, which is at war with the Nation that imprisoned him. But they cannot attempt any military action to liberate him due to the reprisals that the Enemy would be able to take on the countless captives that they hold in their terrible prisons, in addition to that of the tower. It is then a matter of directing the help in the foreseen way: *to wake him up, orient him, and reveal to him the secret*.

To do so, it is necessary to arrive to him, but how to do so if he has been locked away in the heart of a fortified citadel, saturated with enemies on permanent alert? One must discard the possibility of infiltrating a spy due to the insuperable *ethnic differences*: a German would not be able to infiltrate as a spy in the Chinese army in the same way that a Chinese would not

be able to spy on the barracks of the **W**. Unable to enter into the prison and without the possibility of buying off or deceiving the guards, *delivering a message to the prisoner* remains the only recourse left.

However, sending a message seems to be as difficult as introducing a spy. In effect, in the improbable case that a diplomatic maneuver would obtain authorization to present the message and the promise that it would be delivered to the prisoner, it would be of no use because the very fact that it would have to go through seven levels of security, where it would be censored and mutilated, makes this possibility completely useless. Moreover, by such a *legal route* (prior authorization), the condition would be imposed that the message be written in a clear language and accessible to the Enemy, who would then censor part of its content and change the terms to avoid a possible second cyphered message. And let us not forget that the secret of the hidden exit interests the prisoner who finds out about it as much as the Enemy who ignores it. And the first thing: what to say in a mere message to get the prisoner to *wake up*, to *orient* himself, to understand that *he must* escape? No matter how much we think about it, it will become evident in the end that the message *must be clandestine* and that it *cannot be written*. Neither can it be *optical* due to the fact that the small window in his cell allows him to observe only one of the interior courtyards, to where signals from the exterior of the prison do not usually reach.

Under the conditions that I have presented, it is certainly not evident how his *Kameraden* can come up with a solution to the problem and help the prisoner to escape. Perhaps it will come to light if one bears in mind that, in spite of all the precautions taken by the Enemy to keep the captive disconnected from the exterior world, they *were not able to acoustically isolate him*. (For this they would have had to keep him, like *Kaspar Hauser*, in a soundproof cell.)

Let us now see, as an epilogue, the way chosen by the *Kameraden* to offer effective help; a help so that 1°) *he wakes up* and 2°) *it reveals the secret*, to the prisoner, *orienting him toward freedom*.

When deciding on an acoustic way to get the message across, the *Kameraden* understood that they were having a great advantage: *the enemy ignores the original language of the prisoner*. It is then possible to transmit the message simply,

without double meaning, taking advantage of the fact that it *will not be understood by the enemy*. With this conviction, the Kameraden did the following: several of them climbed a nearby mountain and, equipped with an enormous conch, which allows greatly amplifying the sound of the voice, they began to emit the message. They uninterruptedly did it, for years, for they had sworn not to abandon the attempt as long as the prisoner was not once again free. And the message descended from the mountain, crossed the fields and rivers, went through the walls and invaded every corner of the prison. The enemies were at first surprised, but, as that language was not meaning anything to them, they took the musical sound for the song of some fabulous and distant bird, and finally they ended up accustomed to it and forgot it. But what was the message saying?

It was consisting of two parts. First, the Kameraden were singing a *children's song*. It was a song *that the prisoner had heard many times during his childhood, back, in the golden homeland*, when the black days of war were still far away and perpetual captivity could only be a nightmare impossible to dream. Oh, what sweet memories that melody was evoking! What Spirit, no matter how dormant it was, would not wake up, feeling eternally young, upon hearing again the primordial songs, those that it heard enraptured in the happy days of childhood, and that, without knowing how, were transformed into an ancient and mysterious dream? Yes, the prisoner, no matter how dormant his Spirit was, no matter how much forgetfulness had closed his senses, would end up awakening and remembering! He would feel the nostalgia of his distant homeland, he would ascertain his humiliating situation, and he would understand that only he who has an infinite valor, an intrepidity without limits, would be able to perform the feat of escape.

If such was the feeling of the prisoner, then the second part of the message will give him *the key* to find the secret exit.

Observe that we have said *the key* and not *the secret exit*. Because it happens that by means of the key the prisoner *will have to look for* the secret exit, a task that should not be so difficult considering the reduced dimensions of the cell. But, as soon as he finds it, he will have to complete his feat by *descending* to incredible profundities, crossing corridors plunged into impenetrable darkness and *climbing*, finally, to remote summits: such is the complicated trajectory of the enigmatic secret

exit. However, *he is already saved* at the very moment that *he initiates the return*, and nothing or no one will be able to stop him.

We only need, to complete the epilogue of the allegory, to say a word about the second part of the acoustic message, that which held the key to the secret. It was also a song. A curious song that was narrating the story of a forbidden and sublime love between a Knight and a Lady already betrothed. Consumed by a hopeless passion, the Knight had embarked on a long and dangerous journey through distant and unknown lands, during which, he became skillful in the Art of War. At first, he tried to forget his beloved, but after many years, and having ascertained that the memory was always keeping itself alive in his heart, he understood that he would have to live eternally enslaved to the impossible love. Then he made himself a promise: no matter the adventures that he had to go through on his long path, or the joys and misfortunes that they entailed, interiorly he would stay faithful to his hopeless love with religious devotion, and no circumstance would be able to move him away from his firm determination.

And like this, the song was ending: remembering that in some place on Earth, now converted into a warrior monk, the valorous Knight marches, equipped with a powerful sword and a lively steed, but carrying, hanging from his neck, a bag that contains the proof of his drama, the *key* of his secret of love: *the wedding ring* that will never be worn by his Dame.

Contrarily to the children's song of the first part of the message, this one was not producing an immediate nostalgia but a sentiment of modest curiosity in the prisoner. By listening, coming from who knows where, in his ancient native tongue, the story of the gallant Knight, so strong and valorous, so *complete* in battle, and yet so sweet and melancholic, so interiorly *torn* by the Memory of A-mor, the captive was feeling himself prey to that modest curiosity that children experience when they sense the promises of sex or intuit the mysteries of love. We can imagine the prisoner pondering, perplexed by the enigma of the evocative song! And we can suppose, too, that he will finally find a *key* in that *wedding ring*... which according to the song would never be used in any wedding. By induction, the idea of the *ring* will lead him to seek and find the secret exit.

This is the allegory. We must now highlight the existing analogies in order to draw important esoteric conclusions from them. In order for the analogical relationship to be clearly evidenced, we will proceed according to the following method: first, we will affirm a premise with respect to the allegorical story of the “prisoner”; second, we will affirm a premise referred to an analogous situation in the “lost Virya”; third, *we compare* both premises and extract the *conclusion*, i.e., *we demonstrate* the analogy.

It is understood that we cannot expose *the totality* of the correspondences without the risk of indefinitely extending ourselves. Therefore, we will only highlight those relationships that are essential for our purpose and we will leave, as an exercise of the reader’s imagination, the possibility of establishing many others.

– 1 –

- a) The prisoner is at the mercy of his guardians, those who keep him in perpetual captivity.
- b) The ego, of the lost Virya, is a perpetual prisoner of “reason,” i.e., of the evolutive animic subject.
- c) The “prisoner” and the ego are analogous.

– 2 –

- a) The “guardians” are the dynamic intermediaries, miserly for certain, between the “prisoner” and the “exterior world.”
- b) “Reason” is the dynamic intermediary, very poor, between the ego and the “exterior world” (in the lost Virya).
- c) The “guardians” and “reason” are analogous (remember that when reason elaborates a “law of nature,” “mathematical principles” and “preeminent cultural premises” intervene).

– 3 –

- a) The “guardians” use a “language of their own,” different from the language of the prisoner, which he has forgotten.
- b) “Reason” uses logical modalities, different from the original “Primordial Hyperborean Language” of the lost Virya, which he has forgotten due to his strategic confusion.
- c) The guardians’ own language is analogous to the logical modalities of the cultural structure.

- 4 -

- a) The first environment of the “prisoner” is his “cell” of the tower, which almost completely contains him with the exception of the openings (door and window) through where the senses can only very weakly extend.
- b) The first environment of the ego is the “unconscious,” which almost completely contains it.
- c) The “cell” of the tower is analogous to the unconscious of the lost Virya. (We consider “collective archetypes” as the content of the unconscious, especially: “mathematical principles” and “mythical elements.”)

- 5 -

- a) In the “cell” there is a “barred window,” by means of which the prisoner obtains a precarious but “direct” image of the exterior world.
- b) Establishing a permanent contact with the ego is the “sensorial sphere,” by means of which it obtains a precarious but “direct” image of the exterior world.
- c) The “barred window” is analogous to the “sensorial sphere” (or “the senses”) in the lost Virya.

- 6 -

- a) In the cell there is a “barred door,” through which the guards enter, and with them the censored news, i.e., by where the prisoner obtains an “indirect” image of the external world.
- b) The ego can form an “indirect” image of the exterior world through “reflection,” i.e., the act by which the “reasoned” information is received.
- c) The “barred door” is analogous to the act of reflecting or perceiving.

- 7 -

- a) The cell of the “prisoner” is in a “tower” and this in a “walled courtyard.” Surrounding the walls are “deep moats,” and then other walls, and other moats; and so on until completing seven rounds of walls and moats. The seven circuits of security of this formidable “prison” are connected to each other by “draw-bridges,” “corridors,” “gates,” “rising grates,” etc. Beyond the last wall extends the “exterior world,” the

country of the Enemy. In synthesis: the “prison” is a static structure that is interposed between the prisoner and the exterior world.

- b) Between the ego and the exterior world is interposed a complex static structure called “cultural.” “Reason,” to make the information of the exterior world “reasonable,” relies on certain elements of said static or “cultural” structure, e.g., the “preeminent cultural premises,” which signify concepts about the perceptions of external cultural entities or objects.
- c) The “prison” is analogous to the “cultural structure.” Also: certain parts of the “prison,” walls, moats, bridges, etc., are analogous to certain parts of the “cultural structure,” i.e., the “preeminent cultural premises.”

Commentary: Keep in mind that, in the allegory, both the “guardians” and the “prison” are intermediaries between the prisoner and the exterior world. But the “guardians” are “dynamic” intermediaries (analogous to “reason” in the lost Virya) whereas the “prison” is a “static” intermediary (analogous to the “cultural structure” of the lost Virya).

– 8 –

- a) Beyond the last wall of the prison extends the “exterior world,” that reality that can never be seen by the “prisoner” due to the fact that the structure of the “prison” limits his movement and that a permanent “guard” makes sure that such a situation is maintained.
- b) The ego, in the lost Virya, is habitually submerged in the profundities of the cultural structure, floating lost among its artificial and static elements and at the mercy of the implacable tyranny that reason exerts. The cultural structure completely surrounds the ego, except for a few cracks where the “sensorial sphere” dimly peeks through. Beyond the cultural structure, as the object of the instinctive and sensorial spheres, extends the “exterior world,” the reality that will never be able to “be seen” (in its truth, “just as it is”) by the lost ego.
- c) The “exterior world” beyond the prison is analogous to the “exterior world” beyond the “cultural structure” that subdues the ego in the lost Virya.

– 9 –

- a) On a nearby mountain, the Kameraden try to help the “prisoner” escape from the “prison.” For it, they send a message, in their native language, using the acoustic medium. In said message, there is a “children’s song,” to “awaken” the prisoner, and a “love song,” with the “ring key,” so that he searches for the secret exit and escapes.
- b) In a hidden “center” called Agartha, the Loyal Siddhas try to help the lost Virya to break the chains that keep them subject to the material world of the Demiurge. For it, they charismatically send a message in the “language of the birds,” using the acoustic cabala. In said message there is a “primordial memory,” to awaken and orient man, and a “song of A-mor,” with the “ring key,” so that he searches for the center, returns to the Origin, and abandons, as a God, the material Hell of Jehovah Satan.
- c) Many analogies, between “a” and “b,” can be established. We will only highlight the most important: the Kameraden are analogous to the Hyperborean Siddhas.

We believe that the nine preceding arguments constitute an efficacious demonstration of the analogical correspondence that exists between the “allegory” and the situation of the lost Virya. But this is not all. I have reserved three components of the allegory, the children’s song, the Song of A-mor, the secret exit, to effectuate a last analogical correspondence and extract the final conclusion.

As the validity of the existing analogical relationship has been evidenced in the preceding arguments, it will not be necessary to recur to the same method in the next commentary: we will consider the analogies that I mention as proven.

Let us now recall the motives that led me to expound the allegory. We were proposing to show, in an analogical manner, the method used by the Hyperborean Siddhas to counteract the action of “Culture,” the strategic weapon of the Synarchy. I previously clarified that the true instrument that the Synarchy uses to keep the lost Virya “asleep,” i.e., in confusion, are the “interior cultural elements.” In this state, the ego is subjected to reason by the cultural structure, the source from which, finally, all mental activity is nourished. Thus it occurs that the ego, i.e., the present consciousness of man, is “directed toward” the world through the cultural structure “by” reason; the re-

sult, I said it several times, is a deformed image of the world and a state of psychic confusion that enormously hinders the “strategic reorientation” of man. Against this situation the Hyperborean Siddhas, just like the Kameraden of the allegory, are ready to come in aid, “sending a message.”

The principal objective is to “circumvent all the walls” and arrive to the prisoner, the ego, with a message of double significance: 1^o) to awaken; 2^o) to orient. For that, the Hyperborean Siddhas charismatically “transmit the message,” *for many millennia*; some hear it, wake up, and depart; others, most, continue in confusion. Of course, it is not easy to recognize the message because it has been emitted in the language of the birds... and its sounds can only be perceived with the Pure Blood.

Is it clear then? The message of the Loyal Siddhas permanently resounds in the blood of the lost Viryas. Whoever does not hear it is because he suffers from strategic confusion or is unaware of its existence, which is the same thing. But how *should* the charismatic message fulfill its function? In two steps. Firstly, the Gods *speak*, in the blood of man, of a primordial memory, of something that occurred *at the beginning of time when the Spirit had not yet been captured by the Gods of matter*. How the Gods manage to do it is a very great Mystery, of which only They can respond. This “primordial memory,” the “children’s song” of the allegory, has been induced with the purpose that it “activates” the Blood Memory proper to the Virya, i.e., that “he feels” his Minne.

If such a thing occurs, then the lost Virya will experience a sudden “nostalgia for another world,” a desire to “leave it all and depart.” Technically it signifies that the Blood Memory has arrived “there where the consciousness, the ego of the lost Virya, was”; generally over a chakra. Such a contact, between the ego and the Minne, is realized independently of the cultural structure and reason; and that is the objective sought by the Siddhas. It has then been possible to arrive at the marrow of the ego, by way of the blood; it will be then, in that fleeting moment, when the “Song of A-mor” will be heard.

We will now speak of the second part of the message, which we have allegorically called, “Song of A-mor.” First of all we will say that such a name is not capricious since the Hyperborean Wisdom teaches that, *from its origin in the physical universe*, i.e., from its synchronization with Time, *the Spirit remains enchained to matter by a mystery of A-mor*. When the

Blood Memory, activated by the first part of the message, *opens a path* (not rational, not cultural) *toward the ego*, then the Loyal Siddhas *sing the song of A-mor*, they make man participate in the Mystery. If his blood is sufficiently pure enough so that the charismatic message can be conscientialized, then man has the possibility of “orienting” himself toward the Origin and remaining definitively “awakened.”

In the Second Dissertation (“Secret Societies and the Thulegesellschaft”) we mentioned the “Mysteries of Antiquity” (of Osiris and Isis, of Mithras, of Dionysus, etc.) as possessors, in the historical past, of authentic remains of the Hyperborean Wisdom of which knowledge was shared only by members of a caste of initiated priests. It is worth clarifying here, if only briefly, the existing difference between these “Mysteries” and the Mystery of A-mor to which the second part of the Siddhas’ message alludes. In the first place, let us remember that the Mysteries of Antiquity were intended to perpetuate esoteric knowledge by means of *initiation*, that is to say: they were fulfilling a *social function*. Secondly, it must be borne in mind that these “Mysteries” are constituted *because of the Kaly Yuga*, in an attempt to safeguard the Ancient Wisdom from universal decadence and from the fall into exotericism. That is to say that from their origins the Mysteries of Antiquity have been *linked to time* (historical), which was always their true foundation.

Contrary to the “Mysteries of Antiquity,” the Mystery of A-mor is neither social (or initiatic) nor is it linked to any Historical Time since its charismatic “transmission” is synchronistic and acausal, and, therefore, “always present.” They only have in common the word “Mystery” but, as this fact may provoke some confusion, we have deemed it useful to clarify it so that one rules out, from the beginning, any belief in the meaning that the Mystery of A-mor may be (as in the “Mysteries of Antiquity”) a mere esoteric knowledge to which may be accessed through “initiation.”

The Mystery of A-mor can only be revealed by the Pure Blood, interiorly, in a transcendent contact with the “ego” that is realized without intervention from cultural or rational categories. It is, therefore, an *absolutely individual* experience, unique to each Virya. Whoever knows the secrets of the Mystery of A-mor is not an initiate but a *transmuted one*, an immortal Siddha or, for a brief time, an “awakened Virya.”

The Mystery of A-mor is a personal discovery, I repeat, unique to each Virya *about the truth of his own fall*. No one can know this secret and continue the same. And no one, much less, would dare to speak of it once the Supreme Experience has taken place. On the contrary, many times the lips are sealed forever, the eyes shut, and the ears closed. The hairs that turn white are not few, no less the minds that sink into the darkness of madness. Because only an infinite valor can sustain, alive and sane, that one who has seen the Deception of the Origins and has comprehended, at last, the *how and the why of his fall*. The weight of the secret being so terrible, it is understood why I say that there can never be, in the world, an indication of the Mystery of A-mor, and only someone irresponsible or mad would affirm the contrary. The Hyperborean Wisdom provides *techniques of blood purification* that aim to *bring the mystery closer*. But the Mystery, in itself, is interiorly discovered, is unique to each man, and *it is not advisable to speak of it*.

The allegorical story of the prisoner has allowed us to present, in a simple way, the method used by the Loyal Siddhas to guide the lost Viryas. The charismatic message manages, if it is heard, to “awaken” the Virya, putting him in contact with his Blood Memory. It then makes him participate in the Mystery of A-mor, the Supreme Experience that *nullifies*, as we said, the cultural Strategy of the Synarchy. But *we cannot* know what the Mystery of A-mor consists in until having individually lived it. There are only the *general indications* that *those who have transmuted and departed* have left. Based on such indications, it can be affirmed that the Mystery of A-mor is experienced by man in *seven different manners* and that that, precisely, is the reason why the Hyperborean Wisdom foresees seven (secret) initiatic ways of liberation.

According to the mode in which the Mystery of A-mor has been gnostically perceived will be the Way of Liberation adopted and that is why a “Way of Mutation” or “of Lightning”; a “Dry Way” or “Right-Hand Path”; a “Wet Way” or “Left-Hand Path”; a “Way of Strategic Opposition” or “Way of Warrior Gnosis for the Absolute Return”; etc., are usually spoken of.

We will not, of course, speak of all the ways of liberation but of that which has a special relationship to this section, i.e., the way of Strategic Opposition, which was followed by the initiates of the SDA. However, we cannot fail to mention that the

Mystery of A-mor, revealed by the Hyperborean Siddhas, is the ancient basis of the tantric systems of Tibet, although at present such yogas have lost their gnostic meaning with the exception of *Kaula tantra*, which still preserves part of the Wisdom.

In the allegory, the second part of the message was quite extensive because it was also referring to “the other ways” of liberation that can “open” the Mystery of A-mor. But the prisoner has found the key in the *wedding ring* and this signifies, analogically, that he has opted for the Way of Strategic Opposition. The message has arrived to him “acoustically,” i.e., gnostically, and, upon becoming aware of its content, by means of the revealed key, he finds, in the cell, *a ring*, which allows him to *open the secret exit*.

The “cell,” according to argument 4, is analogous to the unconscious. But, as a substratum of the unconscious, the cultural structure is found: a “concealed” *ring* on the floor of the cell undoubtedly corresponds to a *mathematical principle*, to an archetypal symbol integrated, “concealed,” in the schema of a Relationship.

The allegory allows us to comprehend, then, that the Loyal Siddhas, with their charismatic message, reveal a mathematical principle that was remaining unconscious in the cultural structure, to which we call the “*principle of the fence*.” Hence:

– IO –

- c) The “Ring” in the cell of the prisoner is analogous to the “principle of the fence,” a mathematical principle, or Collective Archetype, that was remaining unconscious in the lost Virya and that the message of the Siddhas has *uncovered*.

We had demonstrated further back that “in the mental process” that gives rise to the “scientific idea” of a phenomenon, elements from two principal sources concur: the “mathematical principles” and the “preeminent cultural premises.” This is principally verified when formulating a “law of nature,” which explains the behavior of a phenomenon by establishing causal relationships between aspects of it. We will give a simple example: one wishes to “measure” the side of a regular polyhedron. Here the phenomenon is a body with the form of a regular polyhedron, i.e., a “phenomenic entity.” For it, one takes the “graduated ruler,” i.e., a flat surface on which

are engraved units of length and of which we are sure that one of its sides is perfectly straight. The zero of the ruler is made to coincide with the “beginning” of the side that we are going to measure. It is now observed that the “end” of the side coincides with the number five on the ruler and it is affirmed without further ado that “on the polyhedron, the side measures five centimeters.” A series of subjective operations has been carried out, as will be seen, the conclusions of which, however, can be confirmed by other observers; this possibility of verification is what gives weight of a “law of nature” to the mentioned fact.

But it occurs that on the ruler, which we believe to be numbered, in reality are engraved signs that *represent* numbers, not numbers in themselves. The numbers are mathematical principles proper to the cultural structure, in other words, subjective elements, which intervene in the act of “recognizing that the limit of the side coincides with the sign 5.” If we say “it measures five centimeters,” the affirmation of an empirical quality is being performed: “a proportion exists (i.e., a mathematical relationship) between the length of the side of the polyhedron and the length of the terrestrial meridian.” This proportion is fixed or *constant* (= 5 cm) and constitutes a “relationship between aspects of a phenomenon,” in other words, a “law of nature.”

The phenomenon presented itself to us *complete*, integral in its manifestation. However, it is not possible to apprehend it in its totality; as soon as it is observed, *a part* of it becomes eminent, standing out and emphasizing itself above *other aspects*. The *unity* of the phenomenon has been broken in favor of the *plurality* of qualities that one is able to attribute to it. Two square faces are distinguished, and on each face, *four* edges and *four* angles, etc. Then the *measurement* of an edge or side is performed and a “law of nature” is established: “the length of the side is proportional to the length of the terrestrial meridian and its ratio is 5 cm.”

In this operation just described, the “mathematical principles” (when *two* faces, *four* edges, etc., are distinguished) and the “preeminent cultural premises” (when the face, the side, or any other quality became “eminent”) have intervened. The two sources concur in the rational act of “relating” (measuring) aspects of the phenomenon and postulating a “law of nature” (it measures 5 cm) that can be universally verified.

We hope to have made it clear that *mathematical principles* (the *one*, the *two*, the *square*, etc.), by being intrinsic properties of the mental structure, *intervene a priori* in the formulation of a law of nature. As for the “numbers” of the world, those that appear engraved on the graduated ruler, are only *cultural signs of representation* to which are distinguished thanks to conventional learning. There were ancient peoples who were representing numbers with nodes or ideograms; it is presumable that an instrument of measurement composed from a stick on which hieroglyphics have been engraved, would not signify, in principle, anything to us if we are unable to “read” the signs, i.e., to realize the numerical representations.

The “principle of the fence,” uncovered to the consciousness by the message of the Loyal Siddhas, is also a mathematical principle and will intervene “*a priori*” in every phenomenic perception as such. The natural numbers (which are in the mind) allow to “count” (one, two) the halves of that apple (which is in the world). The principle of the fence (which is in the mind) enables us to apply the “law of the fence” onto that phenomenon (which is in the world). We have come a long way to arrive at this conclusion. We will express it now in a general manner: *the principle of the fence will make possible the determination of the law of the fence in every phenomenon and in any relationship between phenomena.*

But the principle of the fence is, generally, unconscious and only those who manage to hear the message of the Loyal Siddhas can incorporate it into the conscious sphere. And only they, the awakened Viryas, will be able to apply the law of the fence in a warlike Strategy that ensures the return to the Origin.

As a last reflection on the allegory, let us say that when the prisoner “pulls on the ring” and discovers the secret exit, he is performing an action analogous to when “the awakened Virya ‘applies the law of the fence,’” according to the Archemonic Technique, and univocally and irreversibly opens a path toward the Vril.

So, the method that the Loyal Siddhas use to counteract “culture,” the enemy’s strategic weapon, has been explained. They send Their message that aims *to awaken* in the Virya the Blood Memory and *to orient* him toward the Vril, his “secret exit.” For the latter, they induce him to discover the “principle of the fence” and then to apply the “Archemonic Technique.”

The principle of the fence *is infallible* for the proposed strategic purposes and can be applied individually as well as collectively. History abounds in examples of Viryas who have applied techniques based on the Hyperborean Wisdom to be immortalized as Siddhas or to lead a pure-blooded people toward collective mutation; as proof of these glorious actions there have remained numerous stone constructions that no one understands in our days because to do so one would have to possess a vision founded on the principle of the fence. To the awakened Virya, knower of the Archemonic Technique, a single glance on the megalithic constructions, or on Montsegur or on the KZ is enough to correctly interpret the Hyperborean Strategy on which its construction was based.

Let us say finally that he who is conscious of the principle of the fence *has overcome* the enemy cultural strategy and *can carry out the double isolation, of the ego and of the microcosm*. The principle of the fence will enable to set the limits of the consciousness, isolating it from the preeminent cultural premises, and transferring the “ego” toward the “center” of the macrocosm, gaining its own time and space, that is, immortality: the microcosm or physical body will have been transmuted into Vajra, the incorruptible matter.

The Berserkers (initiates of the SDA), were applying the principle of the fence in the Valplads through the Archemonic Technique. The Archemon (a “water ring”) topologically divided the Valplads into two parts: an “exterior,” the Valplads proper, and an “interior” or “Plaza.”

When the Berserker has occupied the Plaza and, by means of “Strategic Opposition” applies the law of the fence on the Archemon, the temporal desynchronization is produced and, if the opposition is sufficient, the final independence with respect to the time of the Valplads. But the time of the Valplads is “the transcendent flow of the Demiurge’s consciousness”; to become independent of it, to have a “time of the microcosm’s own,” means to be outside of any determination of “first” or “second order.” The Demiurge has “momentarily” lost His capacity to act on the Virya and this “moment,” one’s own time, is taken advantage of in order *to direct oneself, to advance*, toward the Origin. It is thus possible to conquer the Vril and transmute into an immortal Siddha. But what happens if the center is not reached, either because purity has been lacking, or because one has feared to take the Great Leap? In the case

of Rudolf II we already mentioned the “strategic disadvantage” and described how it drove him to madness. And that is why, as a result of such risks, it is always warned that only he who possesses an infinite valor, and is stripped of every moral or dogma, will be able to use the Archemonic Technique with probabilities of success. But if one has sufficient valor and a total detachment from the “things of the world” it is always possible to perform the operation of “desynchronizing oneself” with the time of the Valplads, although this operation implies a terrible leveling of forces. This is because, during “Strategic Opposition,” a “*belagerung*” or siege war is posed in which the enemy applies all the potency of its Strategy on the Archemon, i.e., against the Plaza. Two Strategies are confronted there, one, the will of the Demiurge set on maintaining the material enchainment of the Virya, the other, the Hyperborean Strategy of the one who has chosen, to undertake the return, to follow the way of Strategic Opposition with his Archemonic Technique. If the Virya decides to continue occupying the Plaza, while looking for the *interior exit*, he must prepare himself to resist an ever-increasing pressure from the enemy. If he decides, on the other hand, to “synchronize” and return to the Valplads, he must prepare himself to face a certain danger of madness, the product of the consequent “archetypal maladjustment,” from which only his blood purity can undoubtedly save him.

We have explained part of the Archemonic Technique; it is now our turn to explain what Strategic Opposition consists in.

The Archemon, such as we have described it, i.e., as the Berserkers were using it, is with all propriety a “strategic fence.” On it the initiate will project the “law of the fence” giving rise to an action of war, the immediate aim of which is to limit a space of the Valplads and subtract it from the Demiurge’s control. Then, as an inevitable effect of the law of the fence, the *belagerung* is raised and the pressure of the enemy siege manifests itself with a certain intensity. If this pressure fails to breach the fence, the position remains “static.” Since this “pressure” signifies that a *force* acts on the fence, it is convenient to draw an analogy with Newton’s third law that says “If object A exerts a force on object B, then object B must exert a force of equal magnitude and opposite direction back on object A.” That is, in the position of static equilibrium, the Virya “contains” the enemy pressure on the Archemon by exerting

an equivalent pressure but of opposite direction; such is the analogical interpretation of the third law. But as the enemy pressure is exerted from all points of the Valplads, one may ask: how can the Virya oppose an equivalent force at all points of the Archemon? At first sight it is noted that this condition is rather difficult to fulfill for a Virya whose physical body does not have perimetrically adequate organs for such an aim. However, although difficult, it is not impossible to find a solution to the problem. But naturally, such a solution cannot be rational.

In principle, let us give an answer to the previous question: it is not strictly necessary for the pressure to be exerted on all points of the Archemon if one applies the hermetic principle “as above, so below” or, better yet, its magical consequence: “in the part is the whole.” With this principle in mind, it is agreed that it is possible to “respond” to enemy pressure “from a part” of the Archemon, such that it represents, for strategic aims, the same as “the whole.” In order to fulfill this condition, John Dee, the Siddha who designed the Archemon that the SDA was using, proposed that the opposition be performed only against a part of the Valplads, which would magically represent the whole, i.e., the “world” of the Demiurge. In theory it would be enough to define a point in the Valplads, since every point in space corresponds to a quantum of psychophysical UEVAC energy through which the Demiurge manifests Himself. But, in practice, man is not endowed to distinguish one point from another. Now, a psychophysical law says:

$$1 \text{ UEVAC} + 1 \text{ UEVAC} = 1 \text{ MAJOR UEVAC}$$

an esoteric relationship between archetypal atoms or quanta of psychophysical energy, which constitutes the true fundament of known profane laws of crystallography. In synthesis: a body, of homogeneous matter or not, can be taken as a major representative of a simple UEVAC, i.e., of a point in space. By a property of the UEVACs—the indiscernible points—the Will of the Demiurge manifests itself in the integrity of the body by sustaining its material structure.

Based not only on concepts of the Hyperborean Wisdom but also on the Hyperborean Tradition, which narrates stories of many Viryas whose strategies culminated successfully, John Dee recommended using stone as the most adequate substance for the practices of Strategic Opposition. There is a

great ignorance about the occult properties of stones, which are not simple solids but fluids; that is to say: flowing substances of which movement occurs in an enormous lapse of time that man, because he has a minimal vital time, is not capable of perceiving. Their slow yield, of the order of millions of years, constitutes an inestimable quality because the creation of a “time of one’s own” also requires a temporal reference pattern, a comparative clock, the period of which is as long as possible.

According to John Dee’s criterion, a small stone placed in the Valplads in front of a certain place of the Archemon, would be a suitable reference point in order to perform Strategic Opposition. But it should not be believed that the “small stone” can be “any” stone. There are psychophysical laws—originated in the sum of UEVAC units—that state the necessity of a due proportion between the size of the human body or microcosm and the size of the stone that represents the macrocosm. This requirement leads to the fact that the stones used in Hyperborean strategies are always of large sizes and, therefore, of a weight of many tons. How to reconcile such a physical limitation with the special characteristics of the AI Strategy designed by John Dee? According to the English Siddha, the right stone must be selected following the traditional rules of the Hyperborean Wisdom, a task that culminates in obtaining a giant rock, perhaps 500 or 1,000 tons. After this step has been fulfilled, then the Berserker proceeds to cut a small piece of rock, which, for magical purposes, will fulfill the same role as the larger rock. Against that fraction of rock the Strategic Opposition will be performed.

We do not think it is necessary to clarify that all these operations must be carried out under a special ritual atmosphere and following traditional but precise guidelines of the Hyperborean Wisdom.

According to John Dee’s instructions, the Berserkers selected an enormous rock, part of a hill in the Bavarian Alps, which they scabbled using flint hammers, since metal was strictly forbidden in this task. After bringing the rock to the “critical size” proportional to the Berserker, they proceeded to break off sixteen small pieces, no larger than a fist, but suitable for performing the opposition.

The hill, with the parent rock, was in the domain of one of the founding princes, i.e., on the lands of the Dynasty; and al-

though this fact provided considerable security, great precautions were still taken in order to prevent anyone from tampering with the critical size. If intentionally or accidentally the larger rock was broken up, the Strategic Opposition would be nullified with the consequent risk of returning to the Valplads at a strategic disadvantage. It is understood then that the parent rock was carefully concealed and that all sorts of sinister legends were woven about that hill with the purpose of chasing away the superstitious inhabitants of the area.

As for the minor rocks, the Berserkers transported them to the place where the Archemon was located and deposited them, as we said at the beginning of this “course of action,” in sixteen trunks, together with some strange warrior vestments. Although the location of the ceremonies was changed several times over the centuries, the arrangement of the Archemon and other ritual elements always conformed to the design that we have already described.

The minor rocks were called *Lapides Oppositionis*⁵⁸ or simply *Lapides* by the Berserkers. The part of the Archemon in front of which the “*Lapis Oppositionis*” is deposited was receiving the name of *Fenestra Infernalis*⁵⁹ or *Fenestra*. The Archemon had to present, at the “*Fenestra*,” an irregularity, something like “saw teeth,” as John Dee had indicated. This irregularity was representing the site of maximum proximity to the Valplads, a quality that would be manifested when the Berserker applied the law of the fence and initiated the Strategic Opposition. To give dimension to the *Fenestra*, ancient principles of the Hyperborean Wisdom were to be followed also.

As a summary of all that has been said, we may now observe a simplified schema of the crypt. Then we will have to return alongside the Berserkers who, already changed their clothing, are preparing to begin a ritual of initiation.

Only a few minutes had passed, but the Berserkers were presenting a notable transformation. On the tables and hung from the iron corbels that were visible on each column, were the rich courtly robes that the nobles wore when descending to the crypt. They were wearing, instead, a curious warlike garb that could not be safely described as belonging to any

58. Latin for “Stones of Opposition.” The singular is “*Lapis Oppositionis*.”

59. Latin for “Hell’s Window.”

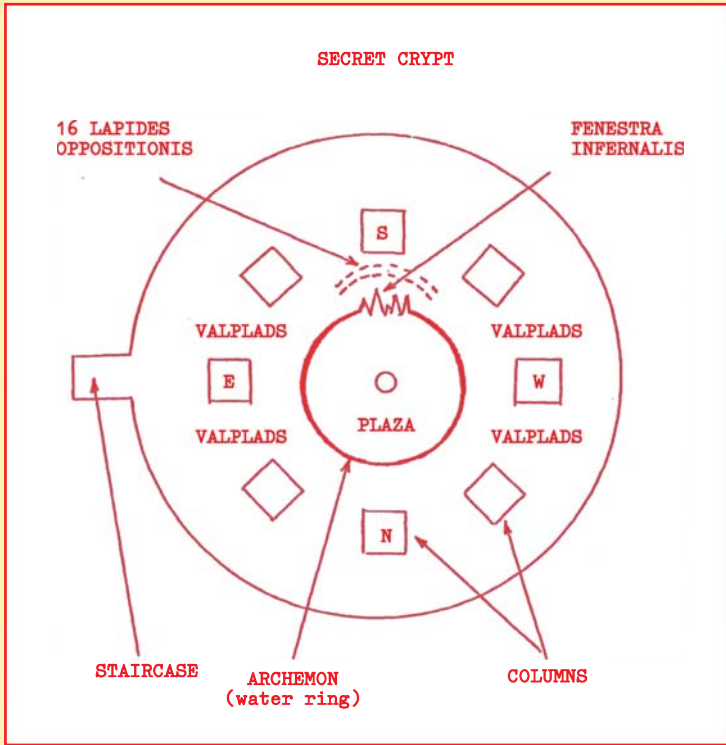

historical people, although its general appearance was undoubtedly Nordic. They had on a doublet of fine leather and, over it, a coat of scale armor (*Lorica Squamata*), forming an ensemble similar to those that the Roman centurions were calling “Cataphract.” They were wearing leather sandals (*Caligae*) and a conical helmet with a nose guard, also of leather, with golden octagonal studs. The dagger and sword hung from a thick belt in simple leather sheaths. The latter was made of iron with an ivory hilt, at the end of which two small “Hallstättic”⁶⁰ antennae were visible, giving an indication of the prodigious antiquity of this “model” of weapon: it was not yet the Cross, but the very ancient Tau, the rune of Thor, the magic sign that was characterizing it. On the left forearm they had placed the shield with three convex sides, passing their hand through two back straps; with this same hand they each took their *Lapis Oppositionis*, the lesser stone. In the right hand

60. From “Hallstatt,” a culture that belongs to the first European Iron Age for anthropology and archaeology (1200–700 BC). According to the Hyperborean Wisdom, there are traces here of a much older heritage, dating back to the Cro-Magnon man.

they were firmly wielding the double-edged axe of black and gleaming iron.

The only two dames, similarly attired, were in no way inferior to that fantastic display of warrior mysticism. They were distinguished from them only by some of the arrangements proper to their sex; otherwise, the same valorous resolution was shining in their eyes as in the rest of those present. Their sword, somewhat shorter, was of the same "Hallstattic" type as the others, but the dagger was not at the waist, but was hanging from their necks in the manner of the Viking women. They were also wearing a leather helmet, from which their hair fell, divided into two braids, each topped by a golden brooch. Lastly: perhaps the most striking detail of the Dames' dress were the two iron hemispheres which, apart from protecting the breasts, were a clear indication of their Amazonian qualities.

Almost at the same instant they all finish dressing and, without saying a word, remain standing by their column, staring toward the Archemon. It is only a moment, in which each one thinks of the terrible ordeal that will immediately ensue. They are fifteen Berserker Siddhas engaged in a war of Gods and Demons, in a war that the majority of men cannot even imagine, for if it were to occur they would surely lose their minds. But what are "men"? Pasús and lost Viryas. Metaphysical warfare is forbidden to them, but also the possibility of salvation, of awakening, of gaining immortality, of returning to the divine Origin... O, how painful the plight of the captive Spirits! And how abominable and odious the captivating Demiurge is to the awakened eye!

The eyes of the fifteen Berserkers flash with wrath: it is as if they were all thinking the same thing and a roar struggled to exit their throats: There can be no truce with Jehovah Satan! He, who has engendered "chosen races" inflated with diabolical pride, who has drawn up Plans counting on the pain of those enchained, who has made a pact with the Traitorous Siddhas of Chang Shambhala and placed them at the head of all His infernal legions, He, cannot be pardoned by man.

The Berserkers' chests heaved rhythmically in a simultaneous breath, while a dull, essential, indescribable fury was seeming to ignite each atom of the blood that was coursing through their veins. The Berserker fury was soon a palpable energy that was radiating from the Siddhas and integrally con-

taminating the whole of that area that they were calling the Valplads. Soon the atmosphere became dense and unbearable, as if reality, subjected to invisible but tremendous tensions, was about to explode. A climate of pent-up violence was emanating from the Berserkers and colliding with the halo of malignity that, little by little, was coming out of every corner of the Valplads. The primordial confrontation, the conflict of the origins, was once again raised. And that dense atmosphere, unbearable for the common man, was instead constituting the eternal, irrefutable proof of the Hyperborean lineage. There, in that hidden crypt, the most ancient miracle was taking place, which is also the most terrible secret: *the mystery of the blood that transforms itself into fire*. The fifteen Berserker Siddhas had brought their consciousness toward the charismatic and racial center, toward Khristos-Lúcifer, and the force of the Vril had filled them, transmuting them into Divine Hyperboreans, i.e., making them be that which they already were, but which they were generously neglecting for seventeen and a half years in order to live in the Valplads and to serve the Race. Now they were all setting out on their way toward the Archemon. It had been only a few minutes since they had changed garments, but the metamorphosis was so complete that not even their closest intimates would have recognized them. Only another Siddha, another Berserker, or some Demon of the Synarchy, upon observing the fierce appearance of those timeless warriors, who were advancing howling and roaring, enveloped in a whirlwind of fire, would have given the right description: this was, without a doubt, the elite of Wotan.

The Berserkers walked, with firm steps, the distance that was separating them from the Fenestra Infernalis. They did so along the Valplads, following the curve of the Archemon's water ring, until reaching the "saw teeth," the irregularity that characterizes the "Fenestra Infernalis." In front of that part of the Archemon, on the floor of the Valplads, sixteen runes of silver, carefully inlaid, were visible. All the same, they were corresponding to the sixteenth letter of the Elder *Fuþark* alphabet, i.e., to the *Sōwilō* rune or *Sól* rune, the sign of which is similar to the lightning bolt in the Younger *Fuþark*.

The Castilian Dame, before any other, with a swift movement, placed her Lapis Oppositionis on one of the runes and, making a prodigious leap, introduced herself into the Archemon. Once in the "Plaza" she fixed her eyes on her Lapis while

applying the law of the fence to the water ring. As she was increasing her opposition on the Lapis and the law of the fence was isolating the Plaza from the Valplads, the Castellana's body was desynchronizing its biological and atomic clocks from "exterior time" in order to stabilize itself in a "time of its own," controlled by the consciousness of the microcosm. It quickly began to spring up like a brilliant vapor from the water ring, while the other Berserkers, also depositing their Lapidēs Oppositionis on the runes, were preparing to enter the fenced Plaza. The Castellana, without a moment's distraction from her operation, pronounced a word in the Enochian language in the form of a password. Instantly one of the Berserkers responded "Freyr," which was the password agreed upon seventeen years before and, without awaiting an answer, leaped over the "teeth" of the Fenestra entering the Plaza. The Castellana, without a moment's distraction from her operation, pronounced a word in the Enochian language in the form of a password. Instantly one of the Berserkers responded "*Freyr*," which was the password agreed upon seventeen years before and, without waiting for an answer, leaped over the "teeth" of the Fenestra, entering the Plaza. Again, the Castellana repeated the "password" leading to the entrance of a second, and so it continued until all had penetrated through the Fenestra after pronouncing the same password. According to tradition in the Dynasty, since the times of John Dee and Wilhelm von Rosenberg, if any blood impurity was submerging the Berserker in strategic confusion during the seventeen years that were elapsing between one ceremony and the other, it would be very difficult for him to pronounce the password *correctly*. And this error would be paid with his life, since the Guardian of the Plaza, in this case the Castellana, *would not open* the Fenestra, subjecting the imprudent one to a spatio-temporal *offset* that would destroy him as soon as he attempted to make the leap.

It is worth noting that the word uttered by the Castellana in the language of the birds would sound to any *profane ear* as if it were listening to *the crowing of the cock*. And this is so because no living being, whose blood is impure with cowardice and fear, can ever understand the cry that the Æsir give from Valhalla to the warriors of Wotan. Instead, *they will always believe "that they heard the crowing of the cock."*

When the last of the Berserkers had entered into the fenced Plaza, the voice of the Castellana was heard once more pronouncing the password. No one responded to the musical word; but a completely new event began to unfold in one part of the crypt. Behind the south column, in the circular gallery, a figure that had hitherto remained completely motionless began to join in. It was a young member of the Dynasty who, for forty-eight hours before, was keeping watch over the weapons, awaiting the moment to prove his valor and his purity of blood. For four long years he had been initiated into the Mysteries of the Hyperborean Wisdom by his uncle and tutor, one of the Berserkers, with an eye to fill the only vacant position in the Einherjar or SDA. He was sixteen years old and, although his profane name was Wilhelm Egon, the Kameraden of the SDA called him, esoterically, *Wilde Jäger*.⁶¹

Since the Berserkers descended the stone staircase, and as long as the warrior qualifying lasted, the young Wildejäger was remaining unmoved, awaiting his turn. It was forbidden for a mere “apprentice-at-arms” to set eyes on the Plaza during the occupancy ceremony; but he had been duly instructed on the manner in which he was to behave thereafter. Hence, he was aware that there was no longer any possibility of turning back: the secret door was locked and the key was in the possession of the Castellana; and if the Berserkers were to find him *alive* in the Valplads, at the conclusion of the ritual, they would proceed to execute him, without any consideration for his kinship. When the warrior has transmuted into a Berserker and the force of the Vril has ignited the blood with icy fire, he reaches a degree of consciousness that is beyond cultural or moral considerations. The berserks-gangr,⁶² the fury of the Berserker, recognizes no other merit than the Pure Blood; whoever confronts a warrior of Wotan’s elite without experiencing *essential hostility* or, what is the same, experiencing *fear for the Origin*, will be immediately attacked by the latter, *whoever he may be*, and surely destroyed.

But Wildejäger was not afraid. With a resolute step he crossed the gigantic pointed arch and went around the South column until situating himself between it and the fifteen Lapidis Oppositionis. When arriving there, he stopped abruptly,

61. Wilde Jäger = Wild Hunter

62. Literally means, “to go berserk.”

not because the ritual indicated it so, but because of the strange scene that presented itself before his eyes. Stupefied, he observed that, along the perimeter of the Archemon, an enormous column was rising upward. It was a cylinder impenetrable to the sight that, at its lower part, up to the height of a man, was flaming and seeming to be of fire; but in its middle and upper part, it was losing density and was like a gray smoke that was becoming blacker and blacker until it was lost in the heights. Just as Wildejäger looked up, he saw with surprise that, in place of the crypt's ceiling, he was seeing, against all reason, a starry firmament. In reality, it was only a portion of the sky, as he recognized almost unconsciously, where he could distinguish, in an impossible perspective, *beyond Ursa*, an unknown constellation made up of a group of five green stars arranged in a circle. In the center of the five stars he thought that he recognized a smaller circle, of a black so intense that it was contrasting against the darkness of the cosmos. It was a kind of black Sun, or at least it was seeming so; of this he could not be sure, for the brightness of the green stars were rhythmically twinkling and their reflections were converging on that black center, merging into a ray, which was crossing among countless stars, until it stopped very close to Wildejäger's astonished sight. The green ray entered *from behind* a star well known to men: the one that fades last in the morning when the Sun gives off its hot light and that the Romans were calling Venus. Wildejäger knew it immediately because he saw, engraved on the star, the sign of the *Anise*, the same Hyperborean sign of the Lords of Venus that he had painted on his shield.

If Wildejäger had eaten anything in recent hours, he would have thought that he was under the influence of a drug; but for forty-eight hours he was keeping watch over weapons while fasting, according to the ancient ritual of warrior initiation that John Dee adopted for the members of the SDA. So, without quite understanding how he had been able *to see* and *to know* all that, the young man looked away from so unsettling a cosmic image and concentrated on his next steps.

For forty-eight hours ago he was dressed in a warrior outfit similar to that which the thirteen male Berserkers were wearing. The only difference was the presence of a *Cornu*⁶³ hanging

63. A kind of horn.

from his neck by a golden cord. In his right hand he carried a double-edged axe; and in his left, a Lapis Oppositionis, together with the triangular shield that was fitted on his forearm.

Seeing that an “S” rune was gleaming uncovered among the fifteen Lapidis Oppositionis, he approached it and placed his own stone on top of it. Then, in a final glance, he looked around the Valplads. He would never again be the same or see reality as ordinary men see it, a mixture of Paśu and lost Virya; he was aware of this and it did not worry him at all; he was only “saying goodbye,” not without a certain irony, to his current blindness and stupidity. His unspeakable daring to “stand up to the world” met with an immediate response; and a halo of evil began to emanate from things, more and more intensely, until converting into a fetid and corrupt miasma that was threatening to surround and suffocate him. Yet Wildejäger, in his years as an “apprentice-at-arms,” had been instructed on how to “close the senses”; and now, faced with the hard test of resisting the onslaught of a world that exchanges its inert and peaceful “appearance” for other more aggressive and frightening illusions, he was displaying the assurance of a skilled warrior. Indifferent to the palpable malignity that was surrounding him, he fixed his eyes on the Fenestra and, bringing the *Cornu* to his lips, he violently blew. A deep sound, hollow and low, lingered for a few seconds, becoming hoarse before slowly dying out. It was undoubtedly a call signal. But the Urg sound that that marvelous instrument was emitting was also possessing other properties, since it was evoking in the listener ancient hunting scenes, carried out by unknown races in remote and forgotten forests. The sound of the *Cornu* was transporting and making one participate in that climate of fierce agitation that the pursuit of the prey produces, irresistibly awakening the primordial instinct of the hunter. This effect was sought after because the initiates of the SDA were affirming that “from a hunting instinct it is much easier to produce the Berserker fury.” For such a reason they had designed a special instrument, according to principles of the acoustic Kabala, which was resonating with the *bija* or universal acoustic root “Urg,” which has the double effect of *evoking* the hunter instinct and of *calling*. The question now arises: calling... to whom?

With this question we have touched upon the most profound meaning of the ritual action, for the fact of *calling* as a

preparatory step to the condition of a *Berserker*, i.e., an initiate of the SDA, by the way of Strategic Opposition, alludes to the Mystery of the Rescue. We already said, on repeated occasions, that the Hyperborean Wisdom teaches seven ways of liberation. However, there is an *eighth way*, called *Exceptional*, of which nothing can be taught or learned, which is why it is rarely mentioned. The Hyperborean Wisdom says nothing about it; and it is Tradition that affirms that “every lost Virya can be *instantly rescued* if he makes the *correct call, even before undertaking one of the seven secret ways.*”

Tradition, although it does not provide esoteric details about this eighth way, uses a “classical analogy” or Nyāya in order to expound the Mystery of the Rescue. The Nyāya tells the story of a warrior who, during the actions of a terrible war, is shipwrecked and trapped in enemy territory. At first he is overcome by despair; but then, because of the great suffering that his shipwrecked condition imposes on him, he resigns himself to his new situation, without being able to prevent bitterness from settling permanently in his soul. He spends a very long time in this state, until one day, overwhelmed by loneliness, he entertains himself by *remembering* the happy days of his military instruction. It is then when something that he had completely forgotten comes to his mind: he sees himself at the moment that he was closing the deal as a warrior; and he sees his military instructor who tells him: “every soldier has the *right to be rescued*”; no matter where he falls or how dangerous the situation is; *his Chief will never abandon him; if you call to him, he will come immediately and you will be evacuated; but do not forget: you must call him, your Chief, because he will recognize you and rescue you quickly.* If you do not proceed in this way, you have only the alternative of attempting to escape on your own, following the secret techniques. The theater of war is too vast and complex *for anyone other than your Chief to recognize you and come to your aid. Remember: call to him.*”

The *Nyāya* concludes with the image of the shipwrecked warrior who is immediately rescued by his Chief, who promptly comes upon *hearing the correct call*. Such is the classical analogy of the Mystery of the Rescue, the eighth exceptional way that confirms the exactitude of the other seven. The call that Wildejäger made with the *Cornu* was symbolically

alluding to the possibility of receiving the immediate rescue, even before undertaking one of the secret ways.

In front of *Wildejäger*, the enormous pillar of fire rose from the Archemon and was lost in the cosmic darkness. The sound of the *Cornu* had not yet died out when voices were heard, coming from some undefined place in the Archemon:

One Voice: Attention Berserkers! Someone is approaching the Fenestra Infernalis!

Another Voice: Tell me, Guardian of the Fenestra, do you know the bold pilgrim? Is he friend or foe?

First Voice: Yes, I know him. It is he whom in the Valplads they call Wilhelm Egon. He seems to have bold intentions.

Second Voice: Guardian of the Fenestra, call the pilgrim to a halt and ask him how we should interpret his daring!

First Voice: Halt, where do you come from and where are you going?

Wildejäger: I do not know exactly where I am because I have been infamously deceived. I wish to flee from hell and for that I have called to my Chief; but I am impure of blood and that has affected the quality of my call. I am left to my own devices and all that is left for me to do is to orient myself and move forward by fighting head-on against the enemy. That is why I request permission to enter your Plaza, because from that *liberated land* I will be able to *direct my sight, orient myself, and fight*.

A murmur of several voices is heard, either approving or condemning Wildejäger's audacity—Finally:

First Voice: (pronounces the password in the Enochian language).

Wildejäger: Freyr!

First Voice: The Fenestra is open. You have permission to enter the Plaza. Now show your valor and intrepidity!

When *Wildejäger* heard the authorization, he readied his shield, raised his ax, leaving his arm ready to unleash a blow, and leaped, over the Lapis Oppositionis, directly into the column of fire. Instantly he disappeared from sight, as the igneous vapor that was springing up from the Archemon, terribly dense, absorbed him completely.

Any observer who knew the *normal* arrangement of the elements of the crypt would have believed, at that moment, that *Wildejäger* must have landed from his jump inside the Archemon, i.e., in the Plaza. But the Archemon was a powerful

magical instrument, activated then by the law of the fence that the Berserkers were applying, and that is why things happened differently. Between the Plaza and the Valplads were not a few inches apart, as common sense was seeming to indicate, but that immeasurable distance that the Berserkers were calling *Hel!*

As soon as *Wildejäger* penetrated the *dense air*, he found himself floating in a limitless space, dimly illuminated by a twilight that no one could tell from whence it was coming. In front of him, but at a very great distance, he could distinguish, with a golden glow, a small circle that was seeming to move farther and farther away. Sharpening his sight he discovered, not without effort, that it was the Archemon itself, with the enclosed Plaza that he was intending to enter. Without thinking, he darted off running in that direction, without thinking how it could be that he was standing in the middle of space; although an interior feeling, which he was trying to nullify, was telling him that the whole thing was the product of a dream. Immediately, when the first claw tore shreds from his shoulder and the blood began to flow, all doubt was dispelled and the truth showed itself in all its dreadful reality: he was in a world of madness, *without points of reference*, soon to face dangers a thousand times more terrible than those of the despised Valplads! The *only* possibility of salvation now was the Archemon, just a shining dot in the distance. If he were to lose sight of it, he would never be able to find it again; and his situation would be much worse than before, lost in that twilight hell. With a blow of his ax he cut down a polyp-shaped monster that was blocking his way and ran desperately in the direction of the Archemon, delivering chopping blows left and right.

It is not our intention to describe in detail the filthy creatures that inhabit Hel and that, adopting all kinds of repugnant forms, present themselves with vile and aggressive intentions by attempting to cut off the passage of any bold intruder. If anyone wishes to delve into such a blackness, they can consult the Egyptian *Book of the Dead* or the *Tibetan Book of the Dead (Bardo Thodol)* or, in any case, read the tales of H. P. Lovecraft.

At first *Wildejäger* managed to advance a little, especially thanks to the effectiveness of his weaponed arm and the anise sign on his shield, which was frightening the demons who did

not dare to attack from his left. However, it soon became clear that it was impossible to keep that advantage, as a cloud of repugnant small beings, no bigger than a hummingbird, but eager to suck blood, rushed at his wounds, while legions of horrifying and evil creatures were competing with each other to take part in the attack.

Step by step Wildejäger moved, dagger in his left and fearsome ax in his right, severing tentacles and claws and splitting nightmarish heads with bloodshot eyes, the gazes of which were conveying the infinite, essential hatred that the Demiurge manifests for the Hyperborean Race. Covered in blood from head to toe, practically blocked by the infernal hosts, Wildejäger suddenly looked away from the combat and desperately searched for the silhouette of the Archemon. Then he saw with horror that a bright dot was very far, *upward*, moving away at a great speed! He was falling, without any doubt, into a dark abyss full of enemies, about to irremediably perish, and to fall again, after death, into a definitive spiritual loss. Wildejäger was thinking of causing a great loss to those who were taking his life and of dying without retreating an inch; but now he was finding that the retreat was taking place *in spite of himself*, by virtue of the fall into the diabolical precipices. This fact shocked him vividly and awakened in him, like a flash of lightning, the memory of his Berserker instructor. Yes, the old Prussian count had spoken wisely that day, two years before, while teaching him the rudiments of Berserker fighting, using *mudras*⁶⁴ of war and pronouncing *mantras*⁶⁵ of power. That time his instructor had told him, now he was remembering it clearly: “nothing and no one can stop a warrior of Wotan’s elite. There are no demons or accidents capable of stopping him if his blood is sufficiently pure. If an abyss stands between him and his goal, the Berserker bridges the gap *by letting out a cry deeper than the abyss.*”

In an instant Wildejäger grasped the meaning of those words and, feeling that his blood was beginning to burn until igniting in a flame of primordial wrath, he uttered the most terrible cry that those dreadful beings ever heard. The cry, “deeper than the abyss,” was a forbidden name, howled with such a ferocity that, along with the sound, rabid foam was

64. *Mudra*: gesture or position with a magical connotation.

65. *Mantra*: word or sound with a magical connotation.

spewing out from the warrior's mouth. His eyes were sparkling with a hatred as indomitable as that which was pulsating in the eyes of the demons, and suddenly, converted into a fiery figure, flaming to the rhythm of that bestial shriek, *Wildejäger* was, in another sense, more frightening than the demons themselves. They must have felt it so; for they began to wildly scatter, and soon left open the passage, through which the already transmuted Berserker rushed like an arrow. His cry and speed were one; and soon the golden disk of the Archemon was so near that he could behold its true aspect, that which the law of the fence, projected by fifteen powerful minds, was bestowing upon it. He saw clearly that a stone construction, of solid appearance, was rising, following the contour of the Archemon; it only had one opening, in the form of a small window, at the place of the *Fenestra*; the roof was a vault perfectly adjusted to the cylindrical perimeter of the wall, which was serving as a wall or a fortified tower, the stones of which were so perfectly cut and assembled that it would have been useless to look for the slightest crack between them.

But he could not see much more; for the end of the cry coincided with the end of the leap. In effect: the horrifying roar was still reverberating in his throat when *Wildejäger* rushed through the small window into the strange fortress. He landed standing on one side of the Plaza, looking fierce and roaring and constantly changing his mudra in a whirlwind of chopping, stabbing, and slashing. He was quickly surrounded by the fifteen Berserkers, who deftly parried his blows while trying to calm the brave *Wildejäger*.

What occurred next is worthy of being narrated in detail; for it will be difficult for synarchized minds to believe... and therein lies its merit. *Wildejäger* had barely recovered from his Berserker-fury attack, and had just lowered his weaponed arm in the presence of his kinsmen, when the fist of one of them smashed violently into his chest. He staggered from the impact and fell backward without being able to avoid it, as a well-aimed leg locked with his own in a deft trip. However, he did not hit the ground. Several Berserkers behind him had stealthily spread out a cloak, holding it firmly by the edges, which hollowed out and quivered upon receiving the defenseless falling body. They then proceeded to pull taut the cloak horizontally, causing *Wildejäger* to soar to a considerable height, to catch him again and repeat the operation several times. The

tossing in the air on a cloak was carried out amidst the laughter and jeers of all the Berserkers who were exteriorizing, in this rude manner, the savage joy that they were feeling for the feat of the young warrior, who had crossed Hel by letting out "a cry deeper than the abyss." And it was also the baptism of camaraderie to the neophyte who joined the golden circle of the Einherjar.

"*Ha, ha, ha,*" the Castellana was laughing, unrecognizably transformed into a Lady of War! "You have become a bear, Wildejäger! A young bear, frenzied and roaring!"

"Yes," asserted another of the warriors, "it is worthy of a Berserker to force a hundred demon cohorts to flee, *ha, ha, ha.*"

And so on and so forth. They were making exclamations of admiration and laughing, without ceasing to toss in the air on a cloak the heroic youth who, far from getting upset, was also laughing loudly, infected by that barbaric joy.

And now that we have seen this curious scene, it is worthwhile to make a brief reflection. Think of this reception that the Berserkers paid tribute to the one who joined them as their equal, after fulfilling the incredible spiritual feat of transmuting himself into an immortal Siddha. Think of this reception full of joy and sincerely manifested delight and compare it with the abject submission that the White Hierarchy demands from its unhappy "initiates." A "synarch initiate" must be ready to kneel down and kiss the effeminate tunics of the Masters of Wisdom and Gurus who will then sweetly rest their holy feet on his humble head and piously plunge it into the mud of enslavement. Think about these two attitudes, compare them and draw a conclusion; then you can choose which path to follow. We, at any rate, will say it here. What an insurmountable difference between the beautiful image of the Berserker fiercely confronting the enemy in order to win his right to spiritual immortality, and after the battle laughing joyfully with his Kameraden, without confrontations or secrets, without hierarchies, all united by a code of honor that only obliges to keep fidelity with Him who is beyond all evil. What a difference, we say, between these gallant warriors and the somber initiates of the Synarchy, organized on the basis of a scale of Terror that humiliates them with a thousand perversities and demands of them very few initiatic "tests," of which perhaps the most picturesque is the defloration of the back-

side through which they are all forced to pass, with greater or lesser joy!

But let us return to the Archemon and contemplate the culmination of Wildejäger's Berserker initiation.

From the interior of the fortress, in the Plaza, it could be seen that the walls of the enclosure were following a perfectly octagonal plan. On each one of the eight walls, a gleaming sword was providing ample illumination. And, even if from the outside Wildejäger saw that the roof was a massive stone vault, looking up he could clearly see a portion of the starry firmament, in which five green stars that were forming a circle around a barely perceptible Black Sun strangely stood out... Just a few seconds before, three unsettling Presences had entered from the sky.

The Siddha Baldur, one of the divine Æsir, was coming in representation of Wotan to celebrate the Minnedrinken, the ceremony where the mead was drunk and where the Gods, and not the weak men, were the ones who were making vows. On that occasion Baldur would commit himself to charismatically guide the future steps of Wildejäger who, by his own decision, would return with the remaining Berserkers to the Valplads in order to continue, for another seventeen and a half years, working in the *Einherjar* for the good of the Race.

Accompanying Baldur were the Valkyries *Sigrún* and *Eir*, one carrying the bottle of mead and the other the glasses of transparent gold. After distributing the glasses, in which Sigrún poured out generous amounts, the sixteen Berserkers and the Siddha Baldur proceeded to shout, "Hrim!"⁶⁶ at the moment in which the cups were clinking; they then drank the contents with respectful circumspection and then, each one, smashed the cup with an accurate ax blow. No one could ever drink from those cups or in any magical way upset the sacred meaning of the Minnedrinken. Eir picked up the destroyed glasses, for that marvelous metal, obtained by alchemical processes, was not to be lost; in Valhalla, skilled smiths would make good use of it in order to construct other utensils.

We must be prudent in relating those parts of the Secret History of the Thulegesellschaft in which the divine Hyperborean Siddhas intervene. If we did not proceed in this way, we would run the risk of profaning the sublime experience

66. Mantra of wine.

that accessing the Presences signifies and, what is perhaps worse, we would give the unsuspecting reader a mistaken, fictional, or unreal idea about the *true* appearance of the Siddhas. This is, no doubt, the *most terrifying* that can be imagined; and only the very valiant manage to come face to face with those who represent *the essence of resolve*. A Gral Knight or a Kshatriya or a Berserker warrior or a Jinin of Japan or a Kaula initiate, etc., may be prepared for such an encounter; but who else is willing to rebel against the tyranny of the Demiurge and undertake the inverse route that the Siddhas point out? Few, very few indeed. And if the majority of the Viryas remain in confusion, seeing the world through the cultural mask, dominated by the Synarchic Strategy, we will not be so naïve as to believe that a further profanation of the Mysteries would make any difference. But neither can we fail to affirm that the Presence of the Hyperborean Siddhas constitutes a *real* experience for those who have sufficiently purified their blood, and not a “symbol” or a mere literary figure. That is why we will not add more details about the subsequent events that occurred after the Minnedrinken, up to the departure of the Siddha Baldur and the two Valkyries.

“Minnedrinken” is only a Germanic denomination for the very ancient ceremony in which the drink or food of the Gods is given to man, initiated or transmuted, to share, for a change. In India, the sacred drink is called *Amrita*; in Persia, *Haoma*; in the Greek Olympus, *Ambrosia*; for the ancient Aryans, *Soma*; for the Germans, *Mead*, etc.; but in all cases it is the same thing: the transmuted man drinks an also transmuted drink, changed in its original characteristics and then endowed with special powers. It is commonly believed that the sacred drink is a drug, consumed by priests and initiates with the purpose of “opening” certain transcendent channels through narcosis or intoxication. This absurd belief presumes to reduce, for example, the Berserker warriors to the level of wretched and vicious “hippies.” It is the Synarchy that uses narcotics and intoxicants in order to undermine and destroy the body of its “adepts,” who seek enlightenment by means of a “journey.” The Hyperborean Wisdom, on the other hand, is obtained by purifying the blood, not poisoning it. The degrees of transcendence that an awakened Virya attains will always be permanent, never transitory and ephemeral like those that have been reached by means of drugs. If this is so, what then is the true

role that the sacred drink plays in the set of secret techniques of spiritual liberation?

In the first place, mead, as well as soma or any other sacred drink, possesses the property of *setting* the Blood Memory that has been previously attained by means of purification techniques or by suitable strategic attitudes. In the second place, let us say that, for such a reason, the sacred drink is never drunk a priori to the transcendent experience: it would not make sense because one would run the risk of *setting* morbid states, which, linked to the consciousness in a permanent way, would end up dragging the one who proceeds in this way to madness. As a synthesis and clear example of what we have said, it is worth remembering that the medieval Germanic troubadours, the *Minnesängers*, were celebrating the ritual of the *Minnedrinken*, during which they were drinking mead and *consecrating* those who had discovered within themselves, in their blood, the presence of a Mystery of A-mor.

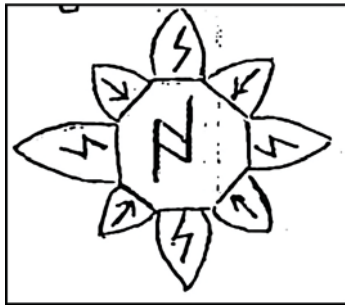

It is worth adding, as a complement, the curious relationship existing between the runic sign of the Anise and another of the sacred drinks, this time from Turkey, “Anisette.” The word “anise” is very ancient, from Atlantean times, and therefore much earlier than the Germanic Fufarks, although the latter are also descended from an Atlantean system: the acoustic Kabala. It has a root “An” which alludes to ancient giant as in “Atlantean” or “Antaeus.” The second part, “Is,” rather than the Egyptian goddess *Isis*, has to do with *Frya* the Norse goddess, mistress of ice, who is a late and Western version of *Lillith*, the Hyperborean goddess associated with the planet Venus. Precisely the rune “*Isaz*,”⁶⁷ the symbol of which is: |, signifies the “goddess of ice” and corresponds to number II in the

67. *Isaz* in the Elder Fufark, *Isa* in Old Norse, and *Iss* in Icelandic

Elder Fupark. Rune number 4, of the same alphabet, is called Ansuz and is consecrated to the *Asir, Wotan*; its Symbol is: ƒ

The union of the runes “Ansuz” and “Is” forms the word “anise,” the runic spelling of which is the following:

This powerful symbol, together with the eight-pointed star, represents the Power of the Lords of Venus: the Berserkers were drawing the “anise” rune within an eight-pointed star as the main symbol of their coats of arms and shields and, as we have already seen, Wildejäger used its power against the demons of Hel.

It is known that “anisettes,” a liquor made from “anise” (*Pimpinella anisum*) is consumed with particular fondness since ancient times in the Near and Middle East. The first name of this umbelliferous plant is of Greek origin, *ánison*, with roots equivalent to those already given for “anise.” The curious thing here is not the coincidence of names but the fact that another liquor, similar in taste to anisette, was chosen by numerous very secret Islamic sects as the sacred drink par excellence. This second liquor, the resemblance of which to anisette is so remarkable *that it cannot be accidental*, is made from the fruit of the *badian* tree (*Illicium verum*). And this is the major coincidence: the capsular fruit of the badian, of an aroma and flavor so similar to anise, is presented in small clusters of *eight* seeds, following a symmetric law so strict that all of them form an octagonal star. It is for this reason that it is called “star anise,” although it is not “true anise,” and we cannot but be struck by the association of the symbols of the Lords of Venus: the name “anise” and the eight-pointed star, not to mention the sacred drink...

When the Berserkers ceased applying the law of the fence on the Archemon and performing strategic opposition against the Lapidés oppositionis, the spatio-temporal offset between the Plaza and the Valplads ceased and soon everything returned to normality in the subterranean crypt. The *dense air* dissipated and the sixteen Berserkers were seen standing at different places in the Plaza, each one of them concentrated on the synchronization ritual, but without abandoning their warrior postures: shield raised and, in the right hand, the ax depicting a threatening semicircle. They had complied with the initiation ceremony and a new member, Wildejäger, had been added to the Einherjar; for another seventeen and a half years no one else would obtain that privilege. But this time a second

ceremony had to be performed, as we have already said, in order to consult the Messiah Game. As the Game is based on principles of synchrony, in order to achieve significant results, it is necessary that no spatio-temporal alteration be exerted on its environment; i.e., the law of the fence must not be applied during its operation. For this reason the Berserkers, after verifying that the synchronization had taken place without problems and that no “surprises” were awaiting them in the Valplads, set out to “prepare” the Game for its use.

In the center of the Plaza a column was supporting the “model” of the nativity scene. Next to its base was a small ark, which was remaining empty year after year, except for the fleeting moments in which the Berserkers were operating the Game, and then it was fulfilling its mission of keeping all the pieces “camouflaged.” The Castellana began to carefully remove the delicate statuettes, which were attached to the board by a thin needle, and hand them to Wildejäger who, gently, was placing them in the ark. Upon extracting the replicas of the Virgin Mother and Joseph, the carpenter, the Castellana proceeded to press with her thumb on the back of each one, at the level between the shoulders. Immediately it slid forward, sliding along the thorax of both statuettes, a split so cleverly concealed that it would easily have escaped the most rigorous inspection. Each one of these splits had an ivory inlay set with such a perfection that, when sliding, they left behind them the hollow, the exact mold, of their shape. The pieces of ivory, so zealously hidden, were two regular polyhedra of different numbers of sides. These objects, together with an ivory ring extracted from the mouth of a miniature cistern, were constituting the three throwing elements of the Messiah Game.

At the end, only the board was left, since all the figures of the nativity scene had gone to the bottom of the ark. However, the dismantling was still to be completed: with precise movements the Castellana peeled off one edge of the leather cover, which was serving as the “floor” of the nativity scene, and was rolling it up until completely removing it, revealing a second leather surface, delicately engraved and painted.

Now the Messiah Game was ready to be used! The ivory polyhedra were displayed strange symbols, engraved on each one of their faces and painted with colored enamels. The surface of the board was basically representing a map of Europe and Asia, but overloaded with such a profusion of runes and

magical symbols that it was not recognizable as such at first glance. On it would fall the polyhedra and the ring by “detecting” strategic situations by means of the “position” that they showed, which would be analyzed and interpreted by the Berserkers.

The Castellana took her own leather helmet and turned it over, leaving the hollow part upward, like an enormous basin, where she threw the polyhedra and the ring. She then shook the helmet and handed it to the nearest Berserker, who also shook it and passed it in turn, just as the ritual was indicating, to another Berserker. A few seconds later, after having passed through all the hands, the helmet was returning to the Castellana who was ready to perform her roll. Each Berserker adopted, at that moment, a mudra of war and, when the ivory objects flew toward the board, from their fifteen throats emitted in unison: B-LD-R, the name of the Siddha who was the charismatic center of the Einherjar (or SDA). The Castellana did not partake of this ritual and, at the moment of throwing the objects, simply asked aloud: When is the HHH guideline fulfilled?

They rolled the polyhedra and the ring until they stopped at different places on the board. It may be said that while this was occurring, the Berserker’s breathing was seeming to stop as their sixteen pairs of eyes were attentively following the movement of the objects. But, when the latter stopped and left a determinate “position,” several exclamations—some swears and curses—demonstrated that the “answer” was not to the liking of those present.

In order to comprehend such a reaction, it must be kept in mind that the Messiah Game was in reality a “synchronistic state detector,” i.e., a tactical instrument, an element of war. Its function was to “measure” the scope of the strategies in play, using phenomena of “first-degree” determination, i.e., without any other “intentionality” intervening, subject only to the free Play of natural laws, to their mechanical determination. The question and the movement of the objects occur *simultaneously* and that is why it is to be expected that there will be a relationship between the two facts. But such a relationship will never be “cause and effect,” where one phenomenon determines the other, i.e., the question *does not determine* the position of the polyhedra, but it is synchronistic with it; and that is why the “position” is significant. It is necessary to meditate a

lot on the metaphysical implications that this way of acting has in order to understand that by *simultaneously* asking and tossing the objects, *nature cannot avoid giving the answer*. On the contrary, this semiotic response *has been wrested from the Demiurge by a tactical blow from those who know what they do*. Only the Siddhas or awakened Viryas, who master the highest gnosis, can face such a warlike operation, in which one's own strategy is put to the test in open defiance of the enemy's strategy.

What were the Berserkers expecting to find in the "position" of the objects? We said it at the beginning: a precise indication of the HHH guideline. The Messiah game was able to "detect" the Time in which the Envoy of Wotan would come and to express it by means of its "winning position." When the Time of the Envoy was near, the semiotic polyhedra would fall synchronistically, revealing the transcendent fact; then the Einherjar or SDA would fulfill its mission to "find" the Envoy and deliver to him the secrets of the Hyperborean Wisdom; then the Order would be dissolved and the last Berserkers would be free to depart or accompany the Great Chief in his Total War against the "Elementarwesen."

Outside of the "winning position," any other distribution of the objects on the board was infallibly showing the relationship of forces existing at the moment of performing the roll. In other words, an analogical evaluation of the "position" was allowing to know one's own situation and the intensity of the enemy pressure, making possible, with these data, a periodical *objective* verification of the correct progress of one's own strategy.

With these concepts, considering that the greatest aspiration of the Berserkers was to share the glory of *accompanying the Envoy* in his mission to guide and transmute the Hyperborean peoples, one can perhaps comprehend the reason for their expressions of displeasure upon seeing that the objects *had not fallen in the winning position* and they would have to wait, therefore, another thirty-five years until history offered a new *generational* opportunity. Because the fact that, during the operation of the Game, the "winning position" did not appear was fundamentally signifying that *the Race was not yet prepared to receive the Envoy of the Gods*. And then, after the curses and fierce swears that the Berserkers were vociferating when finding that the Time of the Envoy was still far away, they were

sighing and lamenting in grief over the confused situation of the lost Viryas.

But, even if the winning position was not given, an analysis of the polyhedra's placement on the board would give important strategic information. For example, the new "position" indicated to the Berserkers that, as had been the case for many decades, the maximum enemy pressure was registered at a specific place in Southern Germany. The synchronistic state detector let them know this and much more. But we are not going to transcribe here the conclusions that the analyses and evaluations of each "position" were leading to; it would be too extensive and difficult to interpret without previously knowing the concrete form that the Messiah Game was taking. Our intention was simply to transmit an idea about the instrument designed by John Dee as part of element (3) of his AI Strategy, i.e., of the Method that makes possible the achievement of the HHH Guideline. We believe that with what has been said so far about the Messiah Game, this clarifying purpose has been fulfilled.

We will therefore leave the Berserkers of the SDA for the time being. We will abandon the subterranean crypt and its terrible Mystery and we will occupy ourselves with unraveling the last question that subsists in the present Course of Action. It was left pending from the beginning and refers to the question: What procedures are indicated by the Method in order to recognize the Envoy?

It will be useful to go back to the beginning and return to the text (p. 192) that reads:

D. Element Analysis (3) = the method must fulfill, among other things, the following main conditions:

1. It has to give, at any time, an *objective* indication of one's own situation and the enemy's position.
2. It will determine with absolute certainty when the *HHH guideline "is about to be met."*
3. It will enable the SDA *to unmistakably recognize the envoy of Wotan*, that invincible Germanic chief on whom the HHH guideline depends.

As has been said, the Messiah Game was enabling to fulfill conditions 1) and 2) with absolute precision. As for point 3, neither John Dee nor Wilhelm von Rosenberg came up with a way of identifying the Envoy that could be reliably applied in

any epoch. While the “winning position” would reveal with certainty that “the Time of the Envoy has come,” no one could foresee when that event, perhaps several centuries in the future, would take place. This uncertainty was preventing the historical profile of the Great Chief from being described and, therefore, making it difficult to trace the guidelines for his identification.

In 1589, shortly before departing for England, John Dee consulted the Siddhas about condition 3, using, for this purpose, the stone mirror of Princess Papan. The answer obtained, because of its enigmatic and prophetic quality, caused a great surprise in John Dee, Wilhelm von Rosenberg, and the eight princes of the Dynasty. First of all, the Siddhas were affirming that the problem of condition 3 was wrongly posed, since it was not up to the Berserkers to identify the Envoy, but for the latter to demonstrate that he was the Envoy. They then went on to say that a racial Strategy could fail if the meaning of condition 3 was not correctly understood and that, recently, in the time of Frederick II Hohenstaufen, a Grand Strategy had in fact failed because of misunderstandings over the same issue. These surprising arguments led John Dee to repeat the question and request from the Siddhas a concrete answer about the way in which the Envoy should then prove his identity. Predictably, this insistence was not to the liking of the Siddhas, who laconically replied that: “in the thirteenth century the Siddhas sent, to Genghis Khan, the instructions for identifying the Universal Emperor. These instructions are still in force and the HHH Envoy will undoubtedly be the one who can correctly read the Scroll of Genghis Khan.” And the Siddhas refused to give any more information. It is difficult for anyone to imagine the state of alertness, the determination to unravel the enigma, the firm resolution to know the truth, whatever it was; in short, the will to overcome the obstacle that the ten initiates were exhibiting in front of the Mystery represented by that Scroll of Genghis Khan, which no one had ever heard of. In those days of 1589 a feverish psychic activity enveloped the founders who were trying, at any cost, to find an answer and for that, they were resorting to all the esoteric resources available. The AI Strategy was ready for its execution, which began with the foundation of the Dynasty and the search for the “declared objectives,” leaving only condition 3 of the Method to be solved. But, as all the efforts made in order to elucidate the

Mystery then proved fruitless, plans were also set in motion, though without ever abandoning the investigation of the enigma.

John Dee and Wilhelm von Rosenberg were hoping to find a prompt solution, but things did not turn out as they wished, for it was only in the middle of the seventeenth century, during the second generation of the Dynasty's members, that sufficient information was gathered in order to undertake a rational search for the mysterious Scroll. This search bore fruit at the end of the nineteenth century, i.e., more than two centuries later, consuming, in that lapse of time, enormous energies of the SDA, which was feeling more and more pressed by History. However, despite all the difficulties that it brought along, the Mystery of the Scroll of Genghis Khan turned out to be highly beneficial for the SDA and it can be assumed that precisely because of the great magnitude of its importance, it surpassed the evaluation capacity of the founders, who did not see in it more than a difficulty. In reality, the Mystery of the Scroll, the secret plot of which was gradually becoming known, had the virtue of *connecting* the SDA with a Hyperborean current of History abruptly interrupted in the thirteenth century. The SDA was taking up again, in a certain way, that current, which we call the "O" Strategy of the Siddhas, and was updating it in the AI Strategy.

In the next chapter, entitled "Historical Schema of the SDA," we propose to show the secret course followed by the SDA between the seventeenth and twentieth centuries, making it clear that its influence on the History of Europe, in that period, has been more important than what might be supposed. But, for the reasons recently stated, the historical Schema will not begin directly in the seventeenth century, but will include an introduction in which the "O" Strategy and the events of the thirteenth century that gave rise to the Mystery of the Scroll of Genghis Khan will be summarized. The development of this chapter will lead us directly to the twentieth century, to the last two stages of our story: the Germanenorden and the Thulegesellschaft.

Historical Schema of the SDI

I. "O" Strategy of the Loyal Siddhas



In the previous chapter we mentioned "a Strategy that the Loyal Siddhas use in order to counteract 'Culture,' the enemy strategic weapon" and we explained it, by means of an allegory, as consisting in a charismatic message. Said message was pursuing two objectives: 1^o) to *awaken*; 2^o) to *orient* toward the "secret exit," "center," or "Vril"; and, in that particular example, the "exit" was found after discovering "the ring," that is, after having made conscious the *principle of the fence*. However, the second part of the message, the *Song of A-mor* was offering, to whomever would listen to it, the possibility of "finding the exit," by six other ways different from *Strategic Opposition*, (which is based on the principle of the fence). In any manner, this Strategy, such as we have described it, with its seven possible ways of liberation, responds to purely individual objectives, i.e., it is exclusively directed toward the man (lost Virya). That is why it is now up to us to declare that it forms part, the "individual" part, of a larger conception, to which we call: "O" Strategy.

The "O" Strategy is fundamentally directed to obtain the individual liberation of man, but, in certain favorable historical occasions, the Siddhas procure to "orient" the Race as a whole in order to force the collective mutation.⁶⁸ In that case the "leaders," many times "sent" by the Siddhas and other times "illuminated" by Them, are in charge of charismatically projecting the strategic models onto the people, seeking to *re-integrate them into the cosmic War*. So that such a task can be realized with probabilities of success, it is necessary that the "leaders" have an external element, situated in the world, which irrefutably represents the Divide origin of the Race. This external element must also give proof of the commitment assumed by the Siddhas when "inducing" the Viryas to resume the war against the Demiurge and of their resolution to "wait out" the necessary Kalpas while they win freedom. By these conditions, it can be comprehended that said "external

68. The "Fourth Dissertation" discusses, at length, the meaning that should be given to the term "collective" in the Hyperborean Wisdom, which differs from its usual meaning.

element” is a true *Stone of Scandal* for the Demiurge and His demonic hosts, and that all His Power, that is to say, the Great Deception, is set on achieving its destruction or, failing that, preventing it from remaining within man’s reach. But, in spite of the contrariety that such an action was causing in the Enemy, the Siddhas have fulfilled their part of the Primordial Pact and, with an admirable disregard toward the Power of the Infernal Potencies, deposited it in the World and guarded it from any attack so that men or their charismatic leaders *discover it and avail themselves of its significance*.

The “O” Strategy of the Siddhas is, then, directed at the internality of each man through “Charismatic Singing,” trying to awaken in them the Blood Memory and induce them to follow any of the seven ways of liberation. But it also procures to impulse the Race as a whole so that it ceases to march in the “evolutive” or “progressive” direction of History and, rebelling against the Plan of The One, in an inverse leap, transmutes the “animal tendencies of the Paśu” and recovers his divine (Hyperborean) nature. In order to achieve this second purpose, no longer individual but racial, we have said that there is an “external element.” What, concretely, will this “external element” be, this “thing,” to which we have attributed such marvelous properties? It is something of which description alone would take several volumes and that, in order to abbreviate, we will call “Gral.” Being impossible to reveal here a Mystery that has been impenetrable for millions of persons, we will try, as usual, to “approach” it by means of some commentaries.

We were wondering what, *concretely*, this wonderful thing is, which we now know is called the *Gral*. Let us begin there. Concretely, the Gral is a stone, a crystal, a gem; of this there is no room for doubt. *But it is not a terrestrial stone*; of this there is no room for doubt either. If it is not a terrestrial stone there is room to ask what its origin is: the Hyperborean Wisdom affirms that *it comes from Venus* but does not assure that that is its origin. We can suppose, for lack of another clarification, that the Lords of Venus brought it to Earth, from that green planet. But the “Lords of Venus” are not originally from Venus but from Hyperborea, an “original center” that does not belong to the material Universe and the “Blood Memory” of which has led many lost Viryas to erroneously identify it with a “missing” “Nordic” or “polar continent.” According to the Hyperborean Wisdom, the Gral was brought to the Solar Sys-

tem by the Siddhas *immediately after they burst through the Gate of Venus in order to establish themselves in Valhalla*. Be that as it may, there is *another concrete aspect* that should be taken into account: the Gral is a gem that is of the utmost importance to the Siddhas, to the point that *They are not willing to abandon or lose it*. Through camaraderie and solidarity toward the lost Viryas, they have *situated* it in the World; but at the end of Time, the Gral will be recovered and taken back to its place of origin.

To what is owed this measureless interest to preserve the mysterious gem? Because it has been momentarily removed from The Most Beautiful Jewel that has ever been seen in the Universe of The One, from that jewel that no one would be able to imitate in this or in other Worlds: not even the Master Goldsmiths or the Constructor Devas or the Planetary, Solar, or Galactic Angels, etc. Because the Gral is a gem from the Crown of Khristos LúCIFER, He who is purer than the purest of the Siddhas, the only one who can speak face to face with the Incognizable. Khristos LúCIFER is who, *being in Hell, is beyond Hell*. Being able to remain in Hyperborea, in the light of the Incognizable, Khristos LúCIFER has wanted to come in rescue of the captive Spirits, protagonizing the incomprehensible sacrifice of His own *self-captivity*. He has installed himself as the Black Sun of the Spirit, charismatically “illuminating,” from “behind” Venus, through the intermediary of the Paraclete, directly into the blood of the lost Viryas.

How did a gem of the Gallant Lord become tarnished by falling here, to Earth, one of the most repugnant sewers of the Seven Hells? Because He has willed it so. Khristos LúCIFER has delivered the Gral to the Siddhas as a *guarantee* of his commitment to man, of his sacrifice, and *as irrefutable material proof of the divine origin of the Spirit*.

The Gral is, in this sense, a *reflection* of the Divine Origin, which will guide, like a lighthouse, the vacillating course of the Rebel Spirits who decide to abandon the slavery of Jehovah Satan.

We have already seen what the Gral is: a gem from the Crown of Khristos LúCIFER; we will now see what the Gral *represents* for the captive Spirits. Above all, the Gral is linked to the *incarnation of the Spirits*, and its significance must first be sought in relation with such a Mystery. It is explained if we take into account that millions of years ago, when the Trai-

torous Siddhas allied with the Demiurge Jehovah Satan in order to carnalize the Hyperborean Spirits, Khristos LúCIFER delivered his gem so that the Truth of *the Divine Origin could be seen with mortal eyes*. That is why the Gral, placed in the World as proof of the divine origin of the Spirit, *gives meaning to all the Hyperborean lineages of the Earth*. Because of it, the blood of men, still plunged into the most tremendous confusion, will always re-claim its *extraterrestrial inheritance*.

The presence of the Gral, in principle, *prevents the Enemy from denying the Hyperborean ancestors*. But just as the Gral gives a cosmic meaning to the History of man, connecting him with the eternal Race of the Origins, and *divinizes* the Hyperborean lineages of the Earth, so too for the Demiurge, by the presence of the Gral, said lineages become a “cause of scandal” and an object of persecution and scorn, of punishment and pain. The *Divine* Hyperborean lineages will be, from the Gral on, *heretical lineages* “condemned” for all “eternity” (a manvantara) by Jehovah Satan. The Gral has come to awaken undesirable memories, to add value to the past of man; what will then be most attacked will be the memory and the past, and the Synarchic Strategy will aim *to erase* its influence in great measure. We are capable of noticing this attack, which is evident to the gnostic gaze, the *historical* function of the Gral will be comprehended with greater profundity. We will dedicate the following paragraphs to making it evident.

The principal crime of man has been to deny the supremacy of “God,” i.e., of the terrestrial Demiurge Jehovah Satan, and to rebel against His enslavement. But man is a miserable being, immersed in a hell of illusion in which he foolishly feels “at home,” without possibilities of breaking the spell by himself. If he has denied the Demiurge and has “rebelled,” it has been by virtue of an exterior agent, but: what “thing” in the World can be capable of *awakening* man, of *opening his eyes* to his forgotten divinity? “If such a thing exists,” the Demons will say, “it is the most abominable object of material Creation.” But that “thing,” that “abominable object,” is not of this World, and of it the captive Spirit-man has “eaten.” This “green fruit,” which later they will call Gral, is an aliment that nourishes with the *Primordial Gnosis*, i.e., with the knowledge about the Truth of the Origins. Because of the Gral, forbidden fruit par excellence, man will know that he is immortal, that he possesses a Divine Spirit enchained to matter, that he comes from a World

impossible to imagine *from his terrestrial Hell* but for which *he feels nostalgia* and to which *he desires to return*.

Because of the Gral, man has remembered!

Here is his first crime. To remember the Divine Origin will be, from now on, a *terrible sin*; and those who have committed it will have to pay for it; that is the Will of the Demiurge, the "Law of Jehovah Satan." They will be his Ministers, the Demons of Chang Shambhala, those who will be in charge of administering the sentence, collecting the punishment in a currency that is called: pain and suffering. The instrument will be, naturally, incarnation, repeated a thousand times in transmigrations "controlled" by the "Law" of Karma, cynically declaring that pain and suffering are "for the good" of the Spirits, "in order to favor their evolution." If "evil" lies in the blood, then favoring racial mixing will weaken it and poisoning it with the *fear of sin* will turn it impure. The result will be the *strategic confusion* of the Spirit and the complete obscurity about the past of man. "In the past there is nothing worthy of being rescued," sensible people will affirm for millennia, in chorus with the Demons of the Hierarchy. Theology, and even mythology, will speak about the sin of man with the language of the Demiurge: the "sin," the "fall," and the "punishment." "Science," on the other hand, will show us a more discouraging panorama: it will "prove," using fossil filth, that man descends from a proto-simian called a "hominid," that is, from that wretched and despicable animal-man who was the ancestor of the *Paśu*. "Science" has brought the past of man to its most dramatic degradation, "evolutively" linking him with reptiles and worms. For modern man there will no longer be divine ancestors but simians and trilobites. It really takes a superhuman hatred to want man to humiliate himself in so sad a manner.

But let us leave the sad, let us be optimistic. "Why look to the past," the Synarchy will say with the Voice of science and theology, "if man is 'something projected toward the future?'" In the past there is nothing worthy of respect: a few primitive marine crustaceans sunken into the mud trying to reach the terrestrial environment, impulsed by "evolution"; millions of years later, a few simians decide to become men: impulsed once again by the miraculous "law of evolution," they turn into bipeds, make tools, communicate by speaking, lose their hair, and enter into History; and then comes the History of man:

documents, civilization, culture. And in History, implacable evolution continues, now converted into a more inflexible law called dialectics: the mistakes of humanity, wars, intolerance, fascism, are “errors”; the successes, peace, democracy, the UN, the Sabin vaccine, are “successes.” From the dialectic struggle between successes and errors always emerges a superior stage, a benefit for *future* Humanity, confirming the evolutive or progressive tendency. Is not this progressive tendency of History *all the good that can be expected from the past?*

So let us be optimistic, let us look to the future; all the goodness, all the realizations are there: the theologian assures that after a *future* Judgment, the gates of paradise will be opened to the good; the Rosicrucians, Masons, and other Theosophists, situate in the future the moment in which, the “spiritual evolution” partially concluded, man identifies himself with his monad, that is to say, with his “Divine Archetype” and is incorporated into the Cosmic Hierarchies dependent on the Demiurge; and even the materialists, atheists, or scientists, present a happy image of the future: they show us a perfect society, without hunger or diseases, where a man, technocratic and dehumanized, reigns happily over legions of androids and robots.

We will not go into detail about an evident fact: it has been attempted *to erase* the past of man, disconnecting him from his Hyperborean roots; *totally erasing said past has not been achieved*; but, in compensation, a metaphysical fracture has been created between man and his divine ancestors, in such a way that, at present, an abyss separates him from his primordial memories; an abyss that has a name: confusion. Parallel to such a sinister purpose, man has been “projected toward the future,” a euphemism utilized in order to qualify the *illusion of progress* that the members of modern civilizations suffer from. Such an “illusion” is culturally generated by powerful “force ideas” (the “direction of history,” “historical acceleration,” “scientific progress,” “education,” “civilization vs. barbarity,” etc.), skillfully used as a strategic weapon. Men, conditioned in that way, blindly believe in the future, look only toward it, and even the fatalists, who envision a “black future,” admit that if an unforeseeable exception or a miracle offers an “exit” to civilization, it is, by all means, in the “future”; the past is in any case a source of general indifference.

This “evident fact” undoubtedly represents an important triumph for the Synarchy, but a triumph that is not definitive. In effect; we have seen that the maximum pressure of the Synarchic Strategy is applied to *erasing* the past, to obscuring the memory of the Divine Origin, and that such an attack is produced as a *reaction* to the *gnostic action* of the Gral. But the Gral is not only a forbidden fruit, consumed by man in remote times, immediately after his enslavement.

The Gral is a reality *that will remain* in the world as long as the last Hyperborean Spirit continues in captivity. Through the Gral, it is always possible for man to *awaken and remember*.

But, in order to enjoy of its gnosis, it is indispensable to realize that the Gral, as a *reflection of the Origin*, shines in the blood *from the past*. Its light comes *from the reverse direction of time* and that is why no one who has succumbed to the Synarchic Strategy will be able to receive its influence. We already ascertained that a powerful cultural strategy “projects man toward the future” and attempts to erase his past and confuse his memories. But the Gral *should not be sought looking to the future*, since it will never be found this way. In rigor of the truth, the Gral *should not be sought at all*, if by such a verb (*seek*) we understand an action that implies “movement.” Only those who seek the Gral have not comprehended its metaphysical significance and believe, in their ignorance, that it is an “object” that can be “found.” Let us recall one of the medieval stories about the Gral that, although deformed by its Judeo-Christian adaptation, preserves enough elements from the Hyperborean Tradition. In his ignorance, Parsifal, the pure madman, goes out to “seek” the Gral. In his ignorance, he commits the blunder of undertaking the search, chivalrously “traveling” through different countries. This “displacement” *essentially* points *toward the future*, because in every movement there is an immanent and inevitable temporality, and, naturally, Parsifal never “finds” the Gral by “seeking it” in the world. Thus, years pass of useless search until he realizes this simple truth. Then one day, completely naked, he presents himself before an enchanted castle and, once inside, the Gral *appears to him* (he does not discover it) and his eyes are open. He then notices that the *throne is vacant* and decides to claim it, finally becoming King.

The following should be seen in this allegory: Parsifal comprehends that the Gral *should not be sought* in the world (the

Valplads), through time (the flowing Consciousness of the Demiurge), and decides to make use of a *Hyperborean Strategic Way*. For it, *he situates* himself “naked” (without the preeminent cultural premises) in a castle (a “Plaza” fortified by the law of the fence), desynchronizing himself from the “time of the world” and creating a “time of his own,” inverse, which “points toward the past.” Then the Gral *appears* and “opens his eyes” (Blood Memory; Minne). Parsifal notices that “the throne is vacant” (that the Spirit can be recovered) and decides to claim it (he is submitted to the tests of purity of the Secret Ways of Liberation) and is transformed into a King (he transmutes himself into an immortal Siddha).

We hope to have made it clear that the Gral is not to be sought, since it appears only when the consciousness of the Virya has been desynchronized from the time of the world and has been stripped of the cultural mask. We now wish to show another aspect of the enemy reaction that has motivated the presence of the Gral.

Through the Gral, man commits the crime of awakening; he has “sinned,” and the punishment is collected with the currency of pain and suffering, through incarnation and the law of Karma. Those in charge of watching over the Law, and those whom the Hyperborean memory of awakened men most offends, are the “guardian angels,” i.e., the Demons of Chang Shambhala and its White Hierarchy. There is, apart from this, a *direct* reaction *from the Demiurge* that is worth knowing. But, as such a reaction has been repeated many times since the Hyperborean Spirits have been enchained to the yoke of the flesh, a complete exposition would have to cover an enormous span of time, which goes beyond the official History and is lost in the night of Atlantis and Lemuria. Of course, we will not be able to embark on such a story, and that is why we will only refer to the reaction of the Demiurge *in historical times*, but it should not be forgotten that all that is said about this event is *not exclusive to one epoch*, but has already been and will surely be again.

When the naïve question is posed about what the worlds are like from where the captive Spirit comes from, believing that there might be some image that represents the unimaginable Hyperborea, the Hyperborean Wisdom usually responds with a metaphorical figure; it says thus to the ignorant apprentice: “imagine that a speck of dust receives a dim reflection of

the True Worlds, and suppose that, then, said speck is divided and re-organized into infinite particles. Make another effort of imagination and now suppose that the material Universe that you know and inhabit has been constructed with the pieces of that speck of dust. The Hyperborean Wisdom tells us: if you are able to re-integrate, in an act of imagination, the immense multiplicity of the Cosmos into the original speck, then, seeing it in its totality, you will perceive only a dim reflection of the True Worlds. If you are able to re-integrate the Cosmos into a speck of dust, you will only see a deformed image of the Fatherland of the Spirit. That is all that can be known *from here*.”

The metaphor becomes transparent if one considers that the Demiurge has constructed the Universe by imitating a clumsy and deformed image of the True Worlds. He has insufflated His Breath into Matter and has ordered it for the purpose of “copying” the dim reflection once received from the Uncreated Spheres. But neither the substance was adequate nor the Architect qualified for it and, added to these evils, the perverse intention of pretending *to reign as God of the work*, in the likeness (?) of the Incognizable, must be considered. The result is in sight: an evil and demented Hell, in which, long after its creation, through a Mystery of A-mor, countless Eternal Spirits were enslaved, enchained to matter, and subjected to the evolution of life.

The principal characteristic of the Demiurge is evidently imitation, by means of which He has attempted to reproduce the True Worlds and the result of which has been this vile and mediocre Material Universe. But it is in the different parts of His Work where the hallucinatory persistence in imitating, repeating, and copying is noticed. In the Universe, “the whole” is always a copy of “something”: the “atoms,” all similar; the “cells,” which divide themselves into analogous pairs; the “social animals,” whose gregarious instinct is based on “imitation”; the “symmetry,” present in an infinity of physical and biological phenomena; etc. Without extending into more examples, it can be affirmed that the overwhelming formal multiplicity of what is real is only an illusion, a product of the crossing, intersection, combination, etc., of a few initial forms. In truth, the Universe has been made from a few different elements, no more than twenty-two, which support, through their infinite combinations, the totality of existent forms.

Bearing in mind the imitative principle that governs the work of the Demiurge, one can now consider His *direct reaction* when faced with the presence of the Gral.

We said that the Gral *divinizes* the Hyperborean lineages by irrefutably *proving* the truth of the Origin and that the reaction of the Demons has been to consider them as *heretical lineages*, deserving of the most terrible punishment.

But while the Demons were occupying themselves with punishing men with the heavy chains of Karma, quite another would be the attitude of the Demiurge. He, according to His characteristic, has wanted to imitate, and even surpass, the Hyperborean lineages by founding a *Sacred Race* that *directly* represents Him, i.e., that *channels His will*, and, through it, to reign over the incarnated Spirits. A “Sacred Race” that rises in the very midst of the peoples condemned to the pain and suffering of life and that, triumphing over them, ends up inflicting on them the final humiliation of submitting them to the Synarchy of the Demons. Then the Hyperborean lineages, sunken into the mud of spiritual degradation, will exhale their last laments, and those cries of pain, those howls of fright, will be the sweet music with which the Sacred Race will give to their “God” Jehovah Satan, the Demiurge of the Earth.

As we have already said, the Demiurge has many times attempted this enterprise; “the Romani,” e.g., are the ethnic remnant of a “Sacred Race” that prospered in the last Atlantis, when the Siddhas of the Dark Side subjected the Hyperborean lineages to the Synarchy of Horror. There, the incarnated Spirits were precipitated to the most dreadful practices: the divine blood was degraded and confused by means of the indiscriminate mixing of races, and, what is worse, fertile crossings between men and animals were achieved with the aid of black magic; thousands of human victims were immolated in order to satiate the thirst of blood of Jehovah Satan, worshiped there in his Aspect as “God of the infernal hosts.” Cruelty, collective orgy, different forms of drug addiction, etc., were all “customs” that the Hyperborean lineages had adopted, while in the eyes of the “Sacred Race,” the gaze of the Demiurge was shining with joy and the Synarchy of Horror was exercising its tyranny of orichalcum. In such a state of degradation, no longer was anyone capable of receiving the light of the Gral or of listening to the Singing of the Siddhas. That is why Khristos LúCIFER decided to manifest Himself *in the sight of men*. He did

so, accompanied by a guard of Hyperborean Siddhas, and it brought about the end of Atlantis...

But this is an ancient history. In recent times, the Demiurge has resolved to once again *repeat*, in imitation of the Hyperborean lineages, the creation of a “Sacred Race” that represents Him and to which will be reserved the high Destiny of reigning over all the peoples of Earth. With the Blood Pact celebrated between Jehovah Satan and Abraham, the “Sacred Race” is founded, and his descendants, the Hebrews, will constitute the “Chosen People.” Just as the Hyperborean Spirits, divinized by the presence of the Gral, represent the “heretical lineage” par excellence, the Hebrews, against them, will present themselves as the “purest lineage of Earth.”

Israel, a people chosen by Jehovah Satan to be His representative on Earth; what titles will He exhibit as *irrefutable proof* that such is His Will? The Demiurge, following His usual system of “imitating,” reasons in this way: “If by the gem of Khristos LúCIFER, the Gral, the Hyperborean lineage has been divinized, also by a ‘Stone of Heaven’ the stirp of Abraham will be consecrated. I will place in the world a Stone on which My Law will be written as *irrefutable proof* that Israel are the Chosen People, before whom the other Nations must humble themselves.”

Such is the direct reaction of the Demiurge. He chooses, from among the dregs of humanity, the most wretched people and after making a covenant with them, He makes them “grow” in the shadows of powerful kingdoms. When He decides that the time has arrived for the “Sacred Race” to fulfill their historical mission, He “renews the covenant,” delivering the key of Power to Moses. Then Israel, the purest lineage of the Earth, passes through millennia and marches toward its future of glory, while the Empires and Kingdoms collapse into the dust of History. Undoubtedly, the reaction of the Demiurge has been effective and the effects of His Stone, the force of His Law, have been powerful. That is why it is worth asking: what is it, actually, that Jehovah Satan delivers to the Hebrews as an instrument of power and universal domination? We will repeat it synthetically: the “Tablets of the Law” contain the secret of the twenty-two voices that the Demiurge pronounced when He ordered matter and by which every existing thing has been formed. The group of symbols contained in the Tablets of the Law is what from antiquity is known as *Acoustic Kabbalah*. In

Atlantis, this knowledge was at first the patrimony of another “Sacred Race,” but, later on, the Guardians of the Lithic Art, ancestors of the Cro-Magnon and fathers of the White Race, arrived to completely master it.

“The Tablets of the Law” are then “the Stone” that the Demiurge has placed in the World as the metaphysical support for the “Sacred Race” in imitation of the whole “Hyperborean/Gral lineage.” However, as in all the “imitations” of the Demiurge, one should not see here an equivalence too precise. The Gral, from the past, reflects the divine Origin for each one of the Viryas and constitutes an attempt by Khristos LúCIFER to come to the aid of the captive Spirits, or, in other words, the influence of the Gral points to the individual and the spiritual. The Tablets of the Law, on the contrary, point to the collective, between Jehovah Satan and the Hebrew people, and, in addition, their Kabbalistic content reveals the keys that make mastering all the material sciences possible.

If strategic confusion, incarnation, enchainment to the Law of Karma, etc., are terrible evils that afflict the Hyperborean Spirits, the terrestrial coexistence with a “Sacred Race” of Jehovah Satan is undoubtedly the most frightful nightmare, even worse than any of the mentioned misfortunes. Because, from the “renewed covenant” with Moses, the *racial* enmity between the Hyperborean (“heretical”) lineages and the Hebrew (“sacred”) lineage will be permanent and eternal, with the irreversible disadvantage, for the first, that the infernal Will of the Demiurge will irresistibly express itself through the second.

After the “appearance” of Israel, the only dramatic alternative left to the Viryas is returning to the Origin or definitively succumbing.

Digging into the Hebrew myth of Abel and Cain, under a veil of calumnies, an accurate description of the racial and theological enmity between Hebrews and Hyperboreans can be assessed. In said myth, Abel, who is a shepherd of flocks, represents the basic *type* of Hebrew and Cain, the farmer, the figure of the Virya. The legend tells that Jehovah Satan was pleased with the blood offerings of Abel the shepherd, consist-

ing of the sacrifice of the firstborn lambs “with their fat.”⁶⁹ In contrast, He disdained the “fruits of the earth” that Cain was exhibiting, whom He finally condemned to bear a “mark,” a “sign,” that would give away his “murderer” status.

This curious affective criterion of Jehovah Satan has been perpetuated through the centuries in the hatred that the Hebrews feel toward the Hyperborean lineages, a hatred which, let us not forget, *comes from the Demiurge*.

It is interesting to delve deeper into the figure of Cain. According to the Bible, he was, in addition to a farmer, the first who *constructed walled cities* and the inventor of weights and measures. His descendant Tubal-Cain (a mythical unfoldment of Cain himself) was a manufacturer of weapons and musical instruments.

If we now observe this figure of Cain, in light of the Hyperborean Wisdom, it will be seen that he possesses many of the characteristic attributes of the Hyperborean lineages. First of all, the association of Agriculture with the construction of walled cities is a very ancient Hyperborean strategic formula that, e.g., the Etruscans and the Romans recently used, and which has been expressed with perfection by the German King Henry I the Fowler, idol of Heinrich Himmler and Walther Darré. On the other hand, the invention of weights and measures, which the Hebrews attribute to Cain, the Greeks to Hermes, and the Egyptians to Thoth, allows to identify Cain with these two Hyperborean Gods. And lastly: the accusation of murderer and the status as a weapons manufacturer clearly reveals that the figure of Cain represents some *fearsome warriors*, perhaps the *Berserkers*: to delate or point out that quality surely points to the famous mark.

In the Bible, the sacred book of the “Chosen People,” in the myth of Abel and Cain, the rules of the game are found perfectly revealed. In the “preference” of Jehovah Satan for the Hebrew shepherds, represented by Abel, and in the disdain for and punishment of the Hyperborean lineages, symbolized by Cain, the metaphysical conflict of the origins appears posed; but now actualized as a cultural and biological confrontation. The Sacred Hebrew Race has come to bring the Presence of

69. In evaluating “blood offerings,” one must never confuse the figure of the “shepherd” with that of the “hunter.” The shepherd is the one who slits the throat of his previously tamed victim. The hunter, on the other hand, like the warrior, obtains his prey after fighting with it and defeating it.

Jehovah Satan (the *conscious* Presence, different from the *pantheistic exhalation* with which the Demiurge animates matter) to the plane of human life, of incarnation, of pain, and of suffering. That is why the ancient transcendent enmity between captive Spirits and Demons is transformed into an immanent enmity between the Hyperborean lineages and the material Universe, given that the Sacred Race is *Malkuth*, the tenth *Sephirah*, i.e., an aspect of the Demiurge. The latter should be understood like this: *Israel is the Demiurge*. It is worth clarifying this. According to the secret teachings of the Kabbalah and as can be read in the Book of Splendor, *Sepher Yetzirah*, turning to the most trustworthy sources of Hebrew Wisdom, for the “creation” of the “Sacred Race,” Jehovah Satan manifests one of his ten Aspects or *Sephiroth*. The tenth Sephirah, *Malkuth (Kingdom)*, is the very people of Israel, according to the official Hebrew texts, which keeps a metaphysical nexus with the first Sephirah, *Kether (Crown)*, which is the supreme Head or Consciousness of the Demiurge.⁷⁰ In other words: there is a metaphysical identicalness between Israel and Jehovah Satan or, if you will, “*Israel is Jehovah Satan*.”

As we were saying before, the enmity between the Sacred Race and the Hyperborean lineages, an enmity that we have seen declared in the myth of Abel and Cain, signifies a confrontation between the latter and the material Universe, given the character of *Malkuth*, an unfoldment of the Demiurge, that Israel flaunts. With *Malkuth*, the Demiurge has wanted to impose *the royalty* of the sacred Hebrew lineage on the remaining peoples of the Earth. If these Gentile peoples *have forgotten the past*, and have submitted themselves to the Plan that the White Hierarchy carries forward, then they will willingly accept the *Hebrew superiority* and the world will march joyfully toward the Synarchy. But, there are those *Goyim* who do not renounce their Hyperborean heritage and persist in remembering the conflict of the origins! There will be no place for them on Earth because with the Presence of *Malkuth*, the sacred lineage of Israel, the Demiurge ensures their persecution and immediate annihilation. Dramatic destiny of the captive Spirit! For millennia *to remember the Origin*, i.e., to exhibit

70. According to the Kabbalah, *Malkuth*, the royalty, is transformed into *Shekhinah* “after the sin of Adam” and will remain so, as the feminine aspect of Jehovah Satan, “until the coming of the Messiah.” In order not to complicate the commentary, we will only use the concept of *Malkuth*.

a heretical lineage, was punished by the Demons with a strong Karma, and the pain, the suffering, were so terrible that one ended up forgetting it. But, while this degradation was occurring, in the depths of his heart, boiling in his blood, the condemned one was able to partake of the Mine and access *Gnosis*; it was his right: if he was able to elevate himself from the swamp of spiritual confusion, no one could prevent him from receiving the light of the Gral or listening to the Singing of the Siddhas. With Israel, not even this miserable opportunity of awakening would any longer be possible, for the conflict was posed in biological, racial, cultural terms... Whoever becomes involved in the conflict must now risk everything, for by confronting Israel, he is confronting the Demiurge Himself.

Israel advances in History with an irresistible force. Its grand ideas are little by little dominating the Culture of the West, parallel with the growth of its financial potency. Who will be capable of opposing the joint force of Judeo-Christianity, Judeo-Masonry, Judeo-Marxism, Zionism, Trilateralism? Who would be able to “force out” the banks of *Rothschild*, of *Jacob Schiff*, of *Kuhn and Loeb*, of *Rockefeller*, etc., and who will compete with the Hebrews in the fields of science or art? We already described in the “First Dissertation” the fantastic *Material Power* reached by the Synarchy; against these organized forces, the Virya does not have the slightest chance. That is why, before such a formidable Power, the only valid strategic alternative is racial confrontation: the Hyperborean lineage of the captive Spirits opposing the Sacred Race of Jehovah Satan. And in this clash of lineages, in this war brought to the terrain of the blood, the awakened Virya, the one who remembers and desires to return, will have to listen to the Singing of the Siddhas and, by following a secret way of liberation, find “the exit,” conquer the Vrils, and transmute himself into a Divine Hyperborean immortal. He will have thus fulfilled the first part of the “O” Strategy. But if an awakened and transmuted charismatic leader puts himself at the head of a racial community and decides to guide the Viryas, *as a whole*, back to the Origin, he will be able to apply the “O” Strategy in its totality, taking advantage of the presence of the Gral. In this case, the leader will raise a Total War against the demonic forces of the Synarchy, but he will especially exert his maximum pressure *on the Sacred Race*, since they *directly* represent the Enemy, that is, the Captivating Demiurge. However, only in modern

epochs, when the universal presence of the Synarchy and the power of the Sacred Race become evident, will it be possible for some Great Chief to correctly identify the Enemy and declare Total War against them.

The irreconcilable enmity between the sacred Hebrew lineage and the heretical Hyperborean lineage could be exemplified by considering the infinite number of times that confrontations have been produced and by describing the different results. We can assure that there would be enough material to fill several tomes, which is the reason why we must be prudent and refer ourselves to what is strictly necessary for the comprehension of the “O” Strategy of the Siddhas. It is with this criterion that we will consider only one example, but an example that will be highly clarifying.

The Hyperborean lineages, since the most remote antiquity and regardless of the historical time or the country considered, have always agreed that human society should be organized around three principal functions: Regal, Priestly, and Warrior. The *harmony* and *independence* of the three functions would guarantee a certain equilibrium appropriate for times of peace and prosperity, that is, *when society materially progresses toward the future*. At different epochs of their history, very many peoples of Hyperborean lineage experienced brief periods in which the balance of the three functions allowed them to enjoy of that mediocre and courtly social tranquility, which in reality was hiding a total absence of charismatic contact between the mass of the people and their Leaders, a typical situation that is characterized by a general indifference.⁷¹ When a society is stabilized in that manner, the White Hierarchy of Chang Shambhala affirms that “it evolves” and that it “progresses.” It is then in the interest of the Demons to bring Humanity to a state of permanent equilibrium of the three functions; with what object? In order to prepare the advent of the Synarchy,⁷² i.e., the Concentration of Power in the hands of a Secret Society or occult confraternity. What is the purpose of concentrating power in the hands of beings who act in the shadows? The answer is related to the manifestation by the

71. The reversion of this social apathy requires the use of a Hyperborean Mystique, a matter that will be dealt with extensively in the Fourth Dissertation of the **ψ** Psychosocial Strategy.

72. The word Synarchy etymologically signifies a Concentration of Power, from *Syn* = “conjoining, concomitant, together with”; and *-archy* = “rule or command.”

Demiurge from "*Malkuth*," the Sacred Race: *the power over the nations belongs* (at this stage of the Kaly Yuga) *to Israel as an inheritance from Jehovah Satan and proof of its theological lineage. While the time of Israel arrives, the Synarchy will be the regent of the power concentrated by the White Hierarchy.*

It is understood that the Siddhas, faced with such a conspiracy, procure to destabilize the synarchic equilibrium of societies and charismatically influence the Viryas with the aim of awakening one of them and transmuting him into a Hyperborean leader. Such is, fundamentally, the objective of the "O" Strategy. That is why the Singing of the Siddhas ceaselessly calls in the Pure Blood and the Gral is a permanent presence that shows, to whomever wants to see it, the reflection of the divine origin of the Spirit. But it should not be believed that the "O" Strategy is only successful when an authentic transmutation takes place of the Virya-man into an immortal Siddha; that is undoubtedly the most important success, but it is not very frequent, especially in the case of leaders or conductors of peoples. There are, on the other hand, other cases, not as spectacular or evident as a transmutation, but whose beneficial influence in the organization of societies has led to them being considered as successes of the "O" Strategy. We specifically refer to those leaders who, with a certain degree of unconsciousness, listen to the charismatic singing and intuit some principles of the Hyperborean Wisdom. As they are not completely awake and ignore the origin of the "message," they proceed to apply the strategic principles in the government of their peoples, taking them as their own invention. We could elaborate on examples, but it will be of particular interest for us to consider the case of those who "have discovered," without knowing it, the principle of the fence.

When the principle of the fence has been incorporated into the mental structure of a leader, his Pure Blood, and with it the Singing of the Siddhas, impulses him to apply the "law of the Fence" in all his concrete acts. Thus, from particular societies emerge political, philosophical, moral theories, etc., conceived and executed according to the law of the fence, in the framework of the "O" Strategy. A typical example is the idea of the "Universal Empire." It is worth commenting on it.

When the "O" Strategy manages to awaken the divine nature in some leader, it is feasible that his subsequent activity provokes notable social changes. If he is king, i.e., if he exerts

the Regal Function, he will ghibellinely advance over the Priestly Function and, with the help of the Warrior Function, he will try to expand the limits of his State. If the leader is a notable warrior, he will not take long in donning the crown and then, crushing the Priestly Function, apply himself to the task of organizing a military State. In the majority of cases, the disequilibrium of the three functions is carried out at the expense of the Priestly Function that tends to be lunar and synarchic. The important thing is that the leader, king or warrior, when applying the law of the Fence in his vision of society, generally concludes by agreeing on the idea of the Universal Empire as the most appropriate in order to demonstrate the superiority of his race and to perpetuate the memory of his stirp.

The universal State of Akkad, the Empires of Assyria and Babylon, the Great Persian Empire, destroyed by Alexander the Great, the Roman Empire; etc., have been conceived in the same way: by the application of the law of the Fence, in the framework of the "O" Strategy, which the Hyperborean leaders have made in the course of the millennia. We cannot fail to mention that many "modern ideas" register the same procedure in their conception: such are the different variants of "nationalism"; fascism, falangism, national socialism, "federations," and "confederations," etc. These and many other political theories are the product of the application of the law of the Fence on the part of some modern leaders. In the case of "fascism," national socialism, etc., it is evident that they keep quite a close nexus with the very ancient idea of the Universal Empire, which eloquently explains why such ideologies have been persecuted to annihilation by the Sacred Race and the forces of the Synarchy.

It is precisely the idea of the "Universal Empire," which is Hyperborean and arises from the application of the law of the fence, that is irreducibly opposed to the idea of the "Universal Synarchy" propitiated by the White Hierarchy of Chang Shambhala, and carried forward in favor of the Sacred Race.

We had proposed to give an example of the irreconcilable enmity between the heretical Hyperborean lineage and the sacred Hebrew lineage and it has been made manifest in the opposition between the Universal Empire and the Synarchy, i.e., between their respective ideal conceptions of society. Equipped with these keys, anyone can review history and draw

their own conclusions; it is not then necessary to insist on it more.

We previously said that the “Sacred Race” was created by the Demiurge in *imitation* of the Hyperborean lineages and we showed that “The Tablets of the Law,” and the terrible knowledge with which they were written, were delivered to the Hebrews in the likeness of the Gral. We may now add that the “imitation” did not conclude there; on the contrary, for centuries an infernal historical falsification was prepared, which in fact was coming to signify a grievance infinitely more offensive than the imitation of the Hyperborean lineages or of the Gral. We are speaking of the usurpation, vulgarization, and degradation perpetrated against the divine figure of Khristos Lúçifer.

We already mentioned that, during the days of the greatest spiritual decadence of Atlantis, Khristos Lúçifer *manifested Himself* in the sight of the lost Viryas. His Presence had the virtue of purifying and orienting many Viryas, who, thanks to this descent into the Infernos performed by the Gallant Lord, were thus able to undertake the path of Return. However, the cowardly reaction of the Siddhas of the Dark Side, who resorted to the use of black magic in order to prevent the rescue, finally led to an all-out war that only concluded when the last of Atlantis had disappeared. And although the Atlantean continent disappeared, devoured by the waters and thousands of years of barbarity and strategic confusion erased these facts from history, it is no less certain that the drama lived through was so intense that it was never totally obscured in the collective memory of the Hyperborean lineages. That is why when the Demiurge conceived the sinister idea of imitating, crudely, the redeeming image of “Khristos Lúçifer descending among men” it was inexorable that such an infamy would unleash irreversible changes and definitive confrontations.

What was the Demiurge intending this time? Although it seems incredible, he was desiring to produce, in *imitation* of the Hyperborean transmutation, *a leap* in humanity. But let us not be too astonished: what was being sought was a leap forward, *toward the future*, and above all, he was attempting to *bind* the members of humanity, without any distinction for their Race or religion, to a universal *psychological type*, that is to say, to a *collective Archetype*. That Archetype, of course, was that of the *Hebrew Race*, since what was definitively wanted

was to *Judaize* humanity and prepare it for the World Government of the Synarchy.

In order to carry forward such an ambitious plan, numerous forces, which would converge toward the figure of the Messiah and would make his terrestrial ministry possible, would be set in motion. For the mission of “preparing the vehicle” through which Jehovah Satan would manifest Himself to men, one of the Masters of Wisdom of the White Hierarchy was commissioned, who would be known, after his incarnation, as Jesus of Nazareth. Neither was the question of lineage neglected, and that is why the Master Jesus incarnated into the bosom of a Hebrew family whose genealogy was traceable back to Abraham. But the physical body of the Messiah would possess a different constitution to that of a simple Hebrew: Mary would be impregnated “with the gaze” by one of the Demons of the Hierarchy, the “Angel Gabriel,” who in reality uses the method of “intersection of fields,” one of the three forms of parthenogenesis that exist. The Master Jesus would animate that superior body for thirty years, but it would be the Essene sect that during all that time would be put in charge of developing his esoteric potentialities, training him in the secrets of the Acoustic Kabbalah. In this task, the Essenes would be assisted by the Masters of the Hierarchy, and these by the Traitorous Siddhas; all Chang Shambhala had concentrated on sustaining the Messiah, since the future “evolution” of humanity would, to a great extent, depend on the success of his mission. If the work of the Messiah was triumphing, the whole of Humanity would be “civilized,” that is to say, Judaized, and the “barbarity,” that is, the mythological memory of the divine ancestors, would come to an end.

The most horrific thing of this conspiracy was that the Demiurge and His Demons were this time counting *on the Blood Memory* that the Hyperborean lineages were still keeping of the Khristos of Atlantis to “attract them” toward His imitation, Jesus Christ, and by means of a fantastic confusion, definitively subdue them. With what colossal hypocrisy the fraud was planned and executed! After Jesus Christ, who would now be capable of distinguishing between the Khristos of Atlantis and His caricature? Only a few have suspected the deception; the Gnostics, the Manichaeans, and the Cathars, and against them has fallen the anathema of the Dark Forces, persecution and annihilation. It is that this Jesus Christ, as the Judaic Ar-

chetype that he is, allows many interpretations, all “legal,” according to the convenience of the Synarchy: there is a redeeming Christ; a Christ of mercy; a Christ “to come”; a Christ God; a Christ man; a social-revolutionary Christ; a Cosmic Christ; a Christ Avatar, etc.

What no one will ever be permitted to conceive (or “remember”) is a Khristos Lux, i.e., a Khristos LúCIFER. After Jesus Christ, that will be the greatest sin, the highest heresy, and the deserved punishment will be an exemplary punishment.

“In year 30 of the Christian Era the Word became flesh, and dwelt among us.” That One, by whose Word the World was created, vested Himself with the robe of His Hebrew Archetype, Malkuth, and manifested Himself to men in the person of Jesus of Nazareth. Phenomenon of phenomena, Marvel of marvels, what prodigious spectacle it must have been to see the Demiurge made man! It must be recognized that this time there is an undeniable quality in His infernal idea of imitating the Khristos of Atlantis and taking advantage of the Blood Memory of the Viryas. The result is in sight. Little by little the peoples came out of “barbarity” and “civilization” was extended to the farthest corners of the Earth. And men, slowly but inexorably, have gone on adapting to the Jewish psychological pattern. How was this success achieved? By what collective alchemy did the ephemeral life of Jesus Christ manage to influence the peoples for millennia until it led to their complete Judaization? Was it only the Blood Memory of the Khristos of Atlantis that determined such a result or were there other hidden factors that contributed to the confusion of humanity and to its current Judaization? Without entering into too many details, given that the subject is lengthy, we can say that the Hebrew Archetype of Jesus Christ, which was, like all Archetypes, on an Archetypal Plane or psychosphere around the Earth, was *precipitated to the physical plane* or *actualized* during the incarnation of the Demiurge in the body of Jesus of Nazareth. Such an actualization of the Malkuth Archetype signifies that *a permanent force* has been established on the Earth, which acts in a manner equivalent to the gravitational, “pulling” man toward the *Judaic form* (morphé, μορφή). It is due to a reason *that is also a terrible secret: Jesus Christ has not disincarnated!* On the contrary, since then, he has situated himself “at the center of the Earth,” next to the King of the World, irradiating from there his “archetypal potency” (today we would say “genetic

information”) in infinite geo-topocentric axes that start from the terrestrial center and pass through the spinal column of men. This is the constant archetypal force of Jesus Christ. But it is not the only one: an *emotional* Judaic influence also acts on man, irradiated from the “Chosen People” of Israel themselves, since the Sacred Race forms part of the occult anatomy of the Earth, fulfilling the function of *Heart chakra* or *Anahata chakra*.

Regarding the last question, it is worth emphasizing that the “animal-man” or Paśu, created by the Demiurge millions of years ago so that “it evolved” according to the Plan that the seven kingdoms of nature follow, was naturally tending to form a *type* that was responding to some basic Archetypes. However, since year 33 of the Christian Era, it can be assured that the Judaic Archetype of Jesus Christ is now the psychological Archetype of the Paśu, i.e., the *type* toward which it tends through evolution. This means that in the Viryas, those who possess an animal inheritance through the ancient Mystery of A-mor, the Paśu tendencies will unconsciously impulse him toward the Judaic Archetype. Only purity of blood will be able to prevent the predominance of the animal tendencies of the Paśu and the consequent danger of psychologically corresponding to the Judaic Archetype.

We have already shown how the Demiurge brought the original conflict to the terrain of the racial confrontation, after creating the Sacred Race in imitation of the Hyperborean lineages divinized by the Gral. Now we have just seen how a new imitation, this time of Khristos LúCIFER, has signified another destructive advance against the Hyperborean lineages. The powerful conforming force of the Judaic Archetype of Jesus Christ, acting from the center of the Earth at all times and places, has tremendously increased the dream in which, since long ago, the “blood consciousness” of men was found. On the battlefield of blood, two esoteric forces now fight to the finish: the Singing of the Siddhas and the Judaic archetypal tendency of Jesus Christ. And the “awakening” has become, then, a terrible and desperate struggle waged in the interior and exterior of each one, *often unconsciously*.

That is why, after Jesus Christ, it will no longer be possible to rate either peoples or organizations, but one will have to specifically take into account the degree of confusion of the men. It must be so because, in many cases, entire synarchic

organizations could fall under the command of a man suddenly conscious of some Hyperborean principle (a product of the esoteric struggle that is being waged in his interior), who could even momentarily “change” the course of the former.

And, vice versa, in other cases it may occur that a group described as “Hyperborean” is led by more or less Judaized personages. In the extreme, we will have Hebrews (Jews of blood) who rebel against Jehovah and dramatically attempt to recover their Hyperborean inheritance, a case that can occur with more frequency than is usually imagined, just as we will many times find persons who “by blood” declare to be perfect “Aryans” but who psychologically demonstrate to be more Jewish than the Talmud. We will have an eloquent example of this by observing the Catholic Church in which the worshipers of Jesus Christ and the Demiurge coexist alongside nationalist and patriotic priests who serve the cause of Khristos LúCIFER and the Siddhas without knowing it.

We must then be prudent when rating human organizations and, even in those clearly synarchic ones, always stop to evaluate the degree of confusion of the men with whom we have to deal. It is considered a show of strategic capacity the ability to locate the “upright man” (even within a synarchic organization such as Masonry), who will then be spoken to by trying *to isolate him* from the organization in which he serves (by appealing to the application of the law of the fence) in order to be able *to address his Hyperborean part* by means of appropriate symbols.

An example of what we have been saying constitutes the case of the soteriological⁷³ heresy, of Pelagius, also called “Pelagianism.” At the beginning of the fifth century, this British bishop began to defend the theory that man, by himself, is sufficient in order to protagonize his salvation. It is possible, according to Pelagius, because “there is, in man, a principle of spiritual perfection.” It is evident to us that the Hyperborean lineage was predominating in Pelagius. His Pure Blood soon enabled him to notice that the “salvation” of man (his “orientation”) was depending on “a spiritual principle” (or Vril), which should be interiorly “discovered” and “cultivated.” But where the “heretical” position of Pelagius was clearest was with re-

73. It is called *soteriology* because it deals with sōtēria (σωτηρία) or the means of salvation and sanctification.

gard to Original Sin: man has not sinned at all and “if Adam sinned, his sin died with him; it was not transmitted to human descendants.” Definitively, “man is free” and “is born without sin”; from there, to pose the injustice of pain and suffering, or of any other punishment imposed by Jehovah Satan, there was only one step. In consequence, the persecution against Pelagius began right away and did not end until his elimination, in Africa; it was carried forward by the most important ecclesiastical authorities of his epoch, which proves the fear that his ideas were producing; among those who stood out were Popes Innocent I and Zosimus, Saint Jerome, and the Gnostic apostate Saint Augustine.

At the Synod of Carthage of the year 418, seven propositions were condemned, a synthesis of his doctrine. It is worth remembering them now in order to prove that they are derived from the Hyperborean Wisdom. Here are the seven condemned propositions:

1. Adam, mortal because of his creation, would have died with or without sin.
2. The sin of Adam harmed him alone, not humankind.
3. Newborn children are in that state in which Adam was before his prevarication (i.e., before tasting the forbidden fruit of the Gral).
4. It is false that, neither by death nor by the prevarication of Adam, the whole human race has to die and must be resurrected by the resurrection of Jesus Christ.
5. Man can easily live sinless.
6. The correct life, of any “freeman,” leads to Heaven in the same way as the Gospel.
7. Before the coming of Jesus Christ there were men who were “faultless,” i.e., who in fact did not sin.⁷⁴

It is time to ask ourselves: what has become of the Gral and its imitation, the Tablets of the Law, after so many centuries of irreducible enmity between Hebrews and Hyperboreans? We will begin by answering the second part of the question. The Tablets of the Law contain the secret of the Acoustic Kabbalah, that is, the description of the twenty-two voices with which the Demiurge concretized creation. In order to preserve this secret from profane eyes, the Tablets were kept in the “Ark of the

74. *Manual de Historia Eclesiástica*, Bernardino Llorca, 1951; p. 180.

Covenant,” while an “interpretation” of the Acoustic Kabbalah was ciphered by Moses in the first four books of the Pentateuch. The twenty-two Hebrew letters, with which the ciphered words were written, keep a direct relation with the twenty-two archetypal sounds that The One Creator pronounced, which grants them an inestimable value as a magical instrument. But such letters possess an archetypal numerical significance, so that every Hebrew word is also a cipher susceptible to being analyzed and interpreted. This is the origin of the Jewish Numerical Kabbalah, which must not be confused with the White Atlantean acoustic *Kabala*, which is related to another system of alphabetic signs. The interpretation of the esoteric content of Scripture is the object of Numerical Kabbalah; but the knowledge thus obtained must be considered, from the magical point of view, as far inferior to the mastery of the laws of the Universe granted by the Acoustic Kabbalah.

But the Acoustic Kabbalah was written on the Tablets of the Law and these enclosed in the Ark, from where they were only able to be removed once a year, for the privilege of the Priests. The Ark was buried in a deep crypt under the Temple, by King Solomon, about a thousand years before Jesus Christ, and it remained in the same place until the Middle Ages, i.e., for twenty-one centuries. We could add *that it was the manner in which it was buried* that prevented the Ark from being found earlier; but this commentary will not clarify anything if one does not possess the esoteric keys.

When Solomon died, the Kingdom of Israel was divided into two parts. The tribes of Judah and Benjamin, who were occupying Southern Palestine, were left under the command of Rehoboam, son of Solomon; and the rest of the country, formed by the other ten tribes, lined up behind the authority of Jeroboam. King Sargon destroyed the Kingdom of Israel in the year 719 BC, and the ten tribes of Jeroboam were transported, in order to serve in slavery, to the interior of Assyria. The remaining two tribes formed the Kingdom of Judah, from which descend, to a greater or lesser extent, the Jews of today.

The “ten lost tribes of Israel” did not disappear from History as the self-interested propaganda of the Jews claims to believe, given that much more is known about the matter than what is said. For example, it is true that there were Hebrews in America and also that a large part of the present population of Af-

ghanistan descends from the primitive members of the Sacred Race. But what interests us is to comment that there was then a migration of Hebrews toward the north, who were guided by a powerful Levite caste. After crossing the Caucasus, where they were decimated by Hyperborean tribes, they arrived at the steppes of Russia and there they clashed with Scythians (they were very inferior in number, they did not affect the ethnic identity of these); but the Levite caste did not accept to lose their status as members of the Chosen People by degrading their blood with the Gentiles. The Levites thus remained, dedicated to the Cult and to the study of the Numerical Kabbalah, for many years, coming to achieve great progress in the field of sorcery and natural magic. When, centuries later, the Scythians were displaced to the west, a part of them established themselves in the Carpathians and on the shores of the Black Sea, while another part were continuing their advance toward central Europe, where they were known as *Celts*. Accompanying the Celts were the descendants of those Levite Priests, now known as *Druids*, those who were wielding a terrible power obtained from the mastery of black magic. And, as we have already said elsewhere, the alliance between the Druids and the Celts would never end, extending to the present day.

How did the Levites of the lost tribes come to be converted into Druids, i.e., how did they obtain their sinister knowledge? The explanation must be sought in the fact that these *Levites*, something that did not occur with other Jewish Priests, neither then nor after, *were not satisfied with the knowledge that was only able to be extracted from Scripture: they were desiring to turn to the authentic Source of the Acoustic Kabbalah*. Their insistence and perseverance to concretize this purpose, and the fact that they were belonging to the Sacred Race, moved the Demons of Chang Shambhala to entrust to them a most important mission; a mission that would require their dynamic intervention in History. The fulfillment of the objectives proposed by the Demons would redound to the benefit of the Levites, since it would enable them to increasingly advance in the knowledge of the Acoustic Kabbalah. What class of mission had the Demons entrusted to them? A task that was having a direct relation with their desires: they would neutralize the lithic instruments that, thousands of years before, the Cro-Magnon men, Atlantean survivors, had constructed throughout the world. But the Cro-Magnons did not only construct megalithic

monuments, but their science was including other alterations to the environment; and the manner in which the Druids were to “neutralize them” was ranging from destruction, the engraving of symbols on the great stones, the modification of their dimensions, or the analogous construction of “other monuments.”

Over the centuries, the Druids became great masters in the Acoustic Kabbalah and we already saw in John Dee’s story how they used when they were desiring to “recover” some of the Atlantean lithic transducers. Later on, we will speak again about the lost science of the Cro-Magnons and the esoteric mastery of the Druids.

While the Druids were marching with the Celts toward Europe, the Kingdom of Judah, in the Middle East, was destroyed by Nebuchadnezzar and its population taken, into captivity, to Babylon in 597 BC. They were liberated in 536 and, twenty years later, in 516, they reconstructed Solomon’s Temple without finding the Ark with the Tablets of the Law. In the fourth century BC, they were dominated by the Greeks of Alexander and in the second century they allied themselves with the Romans against the Greeks (140 BC). After the death of Julius Caesar, the Senate of Rome granted the title of King of Judea to Herod I in the year 37 BC, and in the first year of the Christian Era (or in 4 BC if you will) was born the Savior, Jesus of Nazareth, the Christ.

After Herod I, the Romans took away from the Chosen People the possibility of having a king of their lineage and placed in power a series of procurators who vainly attempted to dominate the growing social agitation. The “crucifixion of Jesus Christ” (which did not exist), or the “struggle against the Christians,” which is usually given as an explanation for the belligerence and suicidal attitude of the Jews, are not correct; the true cause of the unrest being the fact, foreseen by all the members of the Sacred Race, that the Hebrew Archetype “would be cast onto the Gentiles.” By virtue of sharing the substance of the Demiurge, the Judaizing action that would thenceforth be realized over the whole world was palpable for them. What was not appearing so clear to them was: in what way, after the presence of Jesus Christ, could the ancient covenant with Jehovah Satan be fulfilled, the promise that the sacred lineage would inherit the power over other nations? It would take several centuries and the work of eminent kabbal-

istic Rabbis for the Hebrews to recover their faith about their role in History. But while that time was arriving, the patience of the Romans ran out much earlier; in the year 70 AD, General Titus destroyed Jerusalem, Solomon's Temple, and "dispersed" the Jews to all corners of the Roman Empire. With the Diaspora of year 70 begins the modern history of the Chosen People, whose culmination is about to be produced today, when the Synarchy transfers, into their hands, the totality of world power.

When, in 313, Emperor Constantine the Great recognized Christianity as the official religion of the Roman Empire, a difficult epoch was initiated for the Sacred Race. The reason was that the Blood Memory of Khristos LúCIFer was predominating more in the recently Christianized peoples than the Judaic Archetype of Jesus Christ, a fact that was almost always resulting in a generalized anti-Jewish sentiment. Although in the long term the constant influence of the "geo-topocentric ray" of Jesus Christ would end up triumphing over the Hyperborean memory, and the masses would end up Judaized, meanwhile, the Sacred Race would be in danger of being exterminated. But the "threat" would soon be warded off.

Whether there was actually a real danger against the Hebrews is something to be doubted, since in the fifth century Saint Benedict of Nursia founds the Order into which the Druid "Christians" will enter, en masse, who will devote themselves, from then on, to the task of mediating between the Church and the Synagogue.

We said that the Tablets of the Law remained where Solomon had kept them and were only just found in the Middle Ages. With this affirmation our answer does not conclude; but we will have to return very soon, in the next section, to continue with the account. In the meantime, let us try to find an answer to the first part of the question, which was asking: what has become of Gral...?

Contrary to the question about the Tablets of the Law, which obliged us to refer to facts of History, the question of the Gral will take us to strictly esoteric terrain. But first of all, it is worth clarifying that the question has been wrongly posed. We already clarified that the Gral is not to be sought; we will now add that it is an object of which it is not possible to appropriate and that, therefore, must still be where it always was. It is as much an error, then, to "seek" the Gral as it is to question:

what has become of it? But, you may ask, how should one approach that Mystery, then, in order to obtain some additional knowledge, free of paradoxes? The only way, in our judgment, to advance in the knowledge of the Mystery, consists in going deeper into the analogies that link the “orienting function toward the Origin” of the Gral, an external function, with the “secret ways of spiritual liberation” of the Hyperborean Wisdom, which are internal functions, “orienting toward the Origin.”

In this sense, we can establish a very significant analogy between the “Gral Stone” of the “O” Strategy and the “Lapis Oppositionis” used in the way of “Strategic Opposition.”

In the chapter that we have dedicated to the AI Strategy of John Dee, a description was made of the secret ritual practiced by the Berserkers of the SDA, based on the way of Strategic Opposition and the Archemonic Technique. There was shown the Archemon that the Berserkers had constructed in the underground crypt, consisting of a “Plaza” or area enclosed by a ring of water.⁷⁵ By applying the “law of the fence” to the Archemon, *isolating* the Plaza from the Valplads is achieved; i.e., one manages *to liberate an area* in the Demiurge’s world. But this is not enough; it is necessary for the Berserkers to desynchronize themselves from the time of the world and generate their own time, inverse, which enables them to *direct themselves toward the Origin*. For this purpose, they perform *Strategic Opposition against the Lapis Oppositionis, which are situated on a rune in the Valplads, facing the Fenestra Infernalis*.

It is now our turn to approach the greatest secret, that which explains the method used by the Siddhas in order *to maintain*, permanently, eternally if you will, the Gral in the World. We will begin by inquiring the following: which is the *residence* of the Siddhas? We can start from a known answer, which we have repeated many times: the Siddhas reside in Valhalla. Such an answer is correct, but insufficient; for, in turn, one might ask: what is Valhalla? Where is it located? Facing these questions, two criteria can be adopted: one, to resort to elements of Nordic mythology and say, e.g., that “Valhalla, the site where the warriors killed in combat go to reside, ruled by

75. The application by the ancient Hyperborean lineages of this strategic formula has been converted, in the Bible, into the fable that Cain was the first who “fenced an area and walled it” (within which he constructed cities, the Economy of which was based on Agriculture).

Wotan, etc., is located at the top of the Ash Yggdrasil.” And a second criterion, which seems to us more accurate, consisting in stripping the answers of folkloric adornments and expressing them with symbols of the Hyperborean Wisdom, which can be easily interpreted by means of analogies.

With this criterion we can immediately affirm that Valhalla *is the Plaza liberated by the Siddhas* (or Æsir) *in some place of the Universe of The One*. This Plaza, naturally, has the dimensions of a country and is totally fortified. In it inhabit the Lords of Venus and a great many Gods and Valkyries, those who are constantly preparing for the fight while they await the end of the Kaly Yuga and the awakening of the captive Spirits. Its countless warrior Siddhas, immortalized with their bodies of Vajra, form the ranks of the Wildes Heer, the furious army of Wotan, and guard the walls of Valhalla, even though the Enemy would never dare to face so fearsome a Hyperborean garrison.

The Siddhas have liberated the Plaza fortress of Valhalla by applying, with Their Powerful Wills, the law of the fence to the walls of stone. The conquest of their own time that reigns in Valhalla, and which makes them independent of any “cycle” or “law” of the World of the Demiurge, comes from a marvelous operation of Strategic Opposition. But, what will have been the stone, the Lapis Oppositionis, that the Siddhas used in their Hyperborean Strategy? Since the Conflict of the Origins that occurred millions of years ago, the Siddhas perform Strategic Opposition *against a precious extraterrestrial gem provided for this purpose by the Gallant Lord, Khristos LúCIFER. That stone is called Gral: “dieser Stein ist Gral genannt”* (Wolfram von Eschenbach).

The analogical relationship between the Archemon and Valhalla becomes even more evident if we consider that the latter possesses a “*Porta Infernalis*,” equivalent to the “*Fenestra Infernalis*” of the former. The *Porta Infernalis* is an opening in the wall that is permanently watched over by attentive sentinels. Facing the *Porta Infernalis*, but outside of Valhalla, that is to say, in “the world,” *is situated the Gral, upon a rune*; against it, as has been said, the Siddhas perform Strategic Opposition.

It is necessary to go a little deeper into the description of this placement, due to its extraordinary importance, in order to approach the Mystery of the Gral.

In the crypt of the SDA the Lapis Oppositionis were placed on silver runes *enchased on the floor slabs*.

Analogously, the Gral, as a Lapis Oppositionis, *was deposited in the Origin, upon a rune and is still there: upon the rune and in the Origin*. It is not a play on words, but a property of the Gral that must be thoroughly examined: the Gral, as a reflection of the Origin, cannot come to be in time like the material “things” created by the Demiurge; in other words, the Gral cannot be in the present. In truth, the Gral is in the remote past, in that time and place in which it was deposited, and that is why *it must not be sought* by using “movement” (and time) in order to find it, since such an attitude *points toward the future*, that is, in the opposite direction, just as we have already explained. But if the Gral is in the past, if time does not drag it toward the present with its unstoppable fluence, as occurs with material objects, and *has always remained there* (in the past), how is it that we have come to know of it? And, most importantly, how can it *act* in the present, such as the “O” Strategy demands, *regardless of time*, i.e., by virtue of what “element” is the Gral connected, “from the past” to “the present,” e.g., with a Hyperborean leader? The solution to these problems has constituted, since antiquity, a dangerous secret... that we are now going to try to reveal. The enigma is solved by reasoning in this way: while the Gral *has always remained in the past*, a property that the gem of Khristos LúCIFER uniquely possesses in the Universe, *the same has not occurred with the rune that was sustaining it* (and that still sustains it). Here is the Great Secret: while the Gral, a reflection of the divine Origin, remains as such “*situated in the Origin*,” the rune upon which it was seated has traversed millennia and has arrived to the present. Certainly, the rune “is always present,” which means: “in any historical circumstance.” We will speak a little on the rune.

It is known as *Rune of the Origin* or *Rune of Gold*, but it is worth clarifying that such names not only designate the “symbol” of the rune but also the *Terrestrial Stone* that was a primordial seat of the Gral. That is why, when in the Hyperborean Wisdom, an allusion is made to the “Rune of Gold,” what we are actually dealing with is a very ancient stone, violet-blue in color, on which the Siddhas enchased a runic sign of gold. It becomes necessary, then, to know the origin of it and the motive for its construction.

We already mentioned on other occasions that in the beginning the Siddhas entered the Solar System “through the Gate of Venus” and that a group of them, the “Traitorous Siddhas,” “associated themselves to the Plan of the Demiurge, later provoking, in combination with the latter, the catastrophe of the captive Spirits.” The Hyperborean Spirits were enchained to Matter for having fallen into a cosmic trap, the Mystery of A-mor, but we will not speak of it for now. The effect that was produced in the evolutive world of the Demiurge upon assimilating the confused Spirits is what we would call today, a collective mutation. To the evil of the imitative ordering of matter, done by the Demiurge, was later added the evil of the mutation of His Work and the enchainment of the Spirits, that is to say, the modification of the Plan carried out by the Traitorous Siddhas. And in order to “control” such an evil endeavor, the Traitorous Siddhas decide to found the White Hierarchy, in which the different devic manifestations of the Demiurge are to be organized. The “headquarters” of Power, Chang Shambhala, is also the key to the collective mutation of the seven kingdoms of nature. In effect, in what manner was the Demiurge maintaining the *stability of form over the Earth* and how was He ensuring, before the mutation, that the seven kingdoms evolved according to His Plan? There are two principles that intervene in the execution of the Plan, one static and the other dynamic. The Plan *statically* relies on the Archetypes and *dynamically* on the Breath of the Solar Logos, i.e., it was *a force coming from the Sun* (the physical vehicle of the Solar Logos), which was maintaining the evolutive impulse in the seven kingdoms of terrestrial nature. Well, in order to provoke any permanent alteration in the Plan of the Demiurge, *it is indispensable to intercept the energetic current coming from the Sun that, passing through the ocean of prana, converges on Earth*. In order to comply with this condition, the Traitorous Siddhas installed themselves, from the beginning, *between the Sun and the Earth*, in a fixed position that never lets even a single ray of light pass through (that is to say, not even a photon), without first having been intercepted. This affirmation may seem fantastic, and in truth it is, but more fantastic and insensate has been the construction of Chang Shambhala, since what we have described is the “technical” function of the seat of Power of the Traitorous Siddhas.

Here is another “Secret” that is no longer such; the “location” of Chang Shambhala can now be determined from this datum: it is always located between the Earth and the Sun. In reality, Chang Shambhala is very near to the Earth, which will give an idea of its enormous size. However, this is not a whim but it had to be constructed this way because of the exigencies of the solar genetic plasma’s *modulating* function.

Of course, there will be no shortage of those who will foolishly say that all this is nonsense, given that “the traditions of Tibet and India” affirm that Chang Shambhala “is a Kingdom situated in Asia, between the Altai Mountains, the Gobi Desert, and the Himalayas.” Undoubtedly, a comment of this type will constitute a greater nonsense than my affirmations. First, the mentioned “traditions of Tibet and India” are products of the strategic disinformation that for centuries the Hierarchy has deployed so that the truth is ignored. And, in second place, we will say that the most serious data of the Tradition (since there are some data worthy of credit) always mention the *location of the Gate of Chang Shambhala* and never the kingdom itself. This subtle distinction is highly suggestive, since the fact that a gate exists in a determinate geographic place *does not imply that the Kingdom is immediately behind it!* A primitive mind could understand it this way, conditioned by the belief that the straight line is the shortest distance between two points, and in fact such a thing frequently occurs. But here, we are handling the information on another level and that is why we will repeat four verses of the Song of Princess Isa, which we had the opportunity of learning when we studied the story of Nimrod, “The Defeated”:

“But although Dejung is far away,
its gates are everywhere.
Dejung has Seven Gates,
and seven walls encircle it.”

The Oriental legends refer to these “induced gates,” which “are everywhere” and lead to the kingdom that, evidently, does not occupy a simple geographic location.

Our reference to such remote events (the perverse association between the Traitorous Siddhas and the Demiurge), was intended to serve as an introduction to a fact that we will now highlight: when the Demiurge agrees with the Traitorous Siddhas to cede to these the control of the Hierarchy, He delivers

to them *the Tiphereth sign*, which represents one of the ten Sephiroth and permits a total control over the formal aspects of Creation. The Tiphereth Sign is the symbolic expression of the “material manifestation of the divine Archetypes,” an aspect that tends to be synthesized as the “*Beauty of the Demiurge*.” In case it has not been well understood, it is worth repeating that the Demons of Chang Shambhala were left in possession of a sign that represents *the whole* Tiphereth aspect of the Demiurge, permitting them access to it and to share its power. Naturally, the Tiphereth sign is the key to Maya, the illusion of the real, and, therefore, the most terrible tool of sorcery. Whoever observes the Tiphereth sign, which is quite complex, “from the world,” i.e., karmically incarnated, runs the risk of immediately becoming abyssed, losing any point of reference and therefore, reason. That is why the Hyperborean Wisdom recommends applying the law of the fence to the Tiphereth sign in order to be able to observe it without danger. It is not superfluous to point out that in every Hyperborean offensive against the Demons of Chang Shambhala, sooner or later a confrontation with the Tiphereth sign is produced, given that its nefarious influence is relied on for conquering the Viryas.

After the Traitorous Siddhas received the Tiphereth sign and constructed Chang Shambhala, it was no longer possible for the Loyal Siddhas to remain on the Earth’s surface. But neither were they wanting to abandon the Solar System, leaving behind billions of captive Spirits, so they then planned the “O” Strategy. But first, what picture was a captive Spirit presenting? Basically, the loss of the Origin and the consequent unconsciousness, i.e., the loss of its own time. The enchainment to matter fundamentally starts from the enchainment to the “immanent flow of the Demiurge’s Consciousness,” that is to say, the synchronization to the Time of the World. The captive Spirits, bound to Time, were going to take millions of years to recover their consciousness, if ever. Under these circumstances, the Siddhas, in a marvelous exhibition of valor and intrepidity, begin the “O” Strategy.

The first problem that they were to face was maintaining themselves “independent” of Time, but not “outside of it,” since they would have to closely follow the misfortunes of the captive Spirits in order to help them avoid strategic confusion and, eventually, to rescue them. On the other hand, the inde-

pendence of Time was necessary so that the Siddhas could preserve their own time, their consciousness of the Origin, otherwise they would run the risk of also falling into the Great Deception. But, as long as the aeons went on, the Siddhas were to have an agreeable site, fit to be occupied and defended by a garrison of frightful stellar warriors. These were the principal problems; there were others, but we will pass them over in homage to brevity.

The procedure to follow was the following. The Siddhas sought a site on Earth convenient for their purposes. As such a site *was going to disappear* after the Strategic Opposition, they did not choose it *within a continent*, since it would have perhaps caused a cataclysm (which would delay the destiny of the captive Spirits even more). Instead, they searched among the islands and chose one of them, situated in what today would be the extreme north, but which in those days was a tropical zone, immediately proceeding to *fence it*. Being an enormous island, the work to perform in order to construct a cyclopean wall of stone all around its perimeter would today seem an impossible task. But the Hyperborean Wisdom that the Siddhas were having at their disposal gave them the solutions to quickly finish such a job and in a short time a colossal wall was transforming the paradisiacal island into an impregnable fortress. It is not possible to describe the extraterrestrial architecture of the walls, since we would lose ourselves in explanations and would not make much progress; we will only say that, in some sections, the construction was similar to the pre-Incan fortress of *Sacsahuamán* (near Cuzco, in Peru), but such a resemblance, we must also say, was very rough, since Sacsahuamán is still *too human*.

In the wall they made only one opening, something that will surprise those who do not know the strategic principles of the Hyperborean Wisdom. And outside of this opening, which we have already named with a modern denomination: Porta Infernalis, was placed the *Rune of Gold*. The moment has come, then, to return to the greatest Mystery.

The Great Chief, Khristos LúCIFER, audaciously established in an unthinkable place (behind Venus, as the Black Sun or an expression of the Origin), decided to respond to the vile conspiracy of the Traitorous Siddhas with an act of war. In order to comply with His Will, the Hyperborean Siddhas occupied the island and walled it by initiating the "O" Strategy. But the

“O” Strategy had the objective to “awaken” and “orient” the Viryas, individually or racially, we have already said; then, what was the “act of war” consisting in with which Khristos LúCIFer was responding to the treason of the Siddhas of Chang Shambhala? Concretely: the coup de guerre was delivered by the Gral.

The Hyperborean gem, removed from the forehead of the Gallant Lord and seated in the world of the Demiurge, would prevent the Demons from denying the divine Origin of the Spirit, since its untarnishable brilliance, at all times, would give off the reflections of the Primordial Fatherland. The Gral, by divinizing the Hyperborean lineages, was constituting the greatest defiance; for it was threatening to send the infernal plans to failure. The conflict would be, from then on, eternally posed by anyone who managed to awaken, whatever the hell in which he found himself, since the Gral would be seated on the physical plane, that is to say, in the lowest of the infernal regions, and *its brilliance would be seen from all corners of the World*, including the astral plane and all those “purgatories” that the Demons prepare there in order to deceive the Spirits; even on those very subtle planes of the monads emanated by the Demiurge, where there are also completely idiotized Hyperborean Spirits, who have been made to believe that “they must remain there while their, denser, ‘other bodies’ evolve.” Lastly, the Gral was, if the metaphor is permitted to us, a gauntlet thrown in the face of the Demons, for a challenge that these, because of their cowardice, would not be capable of responding to.

But it was not so easy to ensure that the Gral, once entered into the physical plane, simply stayed located in one place, on an altar for example. Because of its atemporal character, as a reflection of the Origin, the Gral, as a true universal diluent, would pass through everything and would be lost from sight... especially if *the Time of the World elapsed* for whoever looked at it. The Gral cannot be seated atop any substance that flows at the impulse of the Breath of the Logos, that is to say, that temporally flows, for *it would be lost in the past, since its essence is always in the Origin*. What to do? It is necessary “to prepare” a material seat in such a manner that it supports (the Gral) *even if it remains in the past and even if the Time of the World effectively elapses for said seat*. Can something like this be constructed? Only if a sign *that neutralizes the temporality* is inter-

calated between the substance of the seat and the Gral. This means that the sign must represent *the inverse movement* to the one used by the Demiurge to construct the Solar System.⁷⁶ A sign like that, which is the height of heretical symbols, was used by the Siddhas in order to construct the seat of the Gral, which we have called the *Rune of Gold*.

Pay attention to this because we will say it only once: from the *Rune of Gold*, which is a very complex sign and of tremendous magical power, is derived, *after a mutilation and deformation*, the Swastika rune, of which so many nonsensical things have been written.

In order to construct the seat of the Gral, a violet-blue color crystalline stone is opted for, similar to an agate. On its upper part, in a slightly concave area, a Rune of Gold, skillfully chiseled by the Siddhas, was enchased. And once the seat was completed, it was deposited outside of the island's walls, in the direction of the Porta Infernalis, but many miles from there, in a continental region.

It will be difficult for anyone to imagine the marvelous spectacle of the Gral descending into the seven hells. Perhaps if one thinks of a green ray, of blinding brilliance and a gnostic influence upon the viewer, before whom the Demons turn their ferocious faces, frozen with fright; a ray that, like the reaping blade of an invincible sword, goes tearing through the four hundred thousand worlds of deception, seeking the heart of the enemy; a flying green serpent that bears between its teeth the fruit of the Truth, denied and hidden until then; if one thinks on the ray, on the sword, on the fruit, on the serpent, perhaps it is thus possible to intuit what occurred at that crucial moment when the truth was placed within reach of the captive Spirits. Yes, because since the Gral was seated upon the Rune of Gold, the Tree of Science was planted within reach of those who, completely confused, were living in hell believing to inhabit a paradise. From now on they would be able to eat of its fruit and their eyes would be open!

Hallelujah for Khristos LúCIFer, the Serpent of Paradise!
Hallelujah for those who ate of the Forbidden Fruit: the awakened and transmuted Viryas!

76. Physical movements must be discarded: $e = dV/dx$. Here, we will refer to "other kind of movements."

What was the next step of the Siddhas? Prior to the fall of the Gral, but when this phenomenon was already occurring on other planes, they applied the law of the fence to the walls of the island, *isolating the interior area from the exterior*. In order to comprehend the effect that such a strategic action produced, one must bear in mind that *this was the first time that a Plaza in the Solar System was liberated*. When a ring of fire seemed to burst forth from the imposing walls and the interior of the island, enveloped in a strange vibratory and flaming cloud, was no longer visible, the Demiurge began to feel His substance amputated. The strategy of the Siddhas was aiming to gain, not only the flat area of the island but also its relief, its mountains and valleys, its lakes and forests, its vegetables and animals; the island, a vast country, was also a gigantic Noah's Ark that for millennia would receive the Viryas who managed to awaken and flee from material chains and also those who had been transmuted by fighting to the death in battles.

A whole country subtracted from the immanent control of the Demiurge was a new experience, but, however this had been possible, the truth is that the island was still there: hidden by a barrier of fire but in the same place. That is why the reaction of the Demiurge made the Earth tremble, seeking to somehow affect that incomprehensible phenomenon and recover the dominion of the "Plaza." Terrible tidal waves tossed the adjacent seas and never-before-seen winds uselessly blew against the titanic walls; the sky was darkened by clouds of ash from suddenly awakened volcanoes and the ocean floor was threatening to split and attempting to swallow the "liberated" island.

The world was seeming to have gone mad, showing the terrifying spectacle of all the "uncontrolled" forces of nature, when, "as if it were the height of abominations," the Gral descended upon the Earth.⁷⁷

What could we add in order to give an idea of what happened there? We already said that it is very difficult to describe (or even mention), an event that generated a perpetual irritation in the Demons. Perhaps this comment may tell someone something: "as the Gral was falling to Earth, beyond the three hundred and seventy times ten thousand Worlds, the Great

77. According to the Hyperborean Wisdom, "two *winged* Siddhas, lieutenants of Khristos LúCIFER, accompanied the Gral in its descent."

Face of the Ancient One let out a howl of horror that *is still heard reverberating* in the confines of the Cosmos.”

As soon as the Gral had been seated upon the Rune of Gold, the Siddhas performed the Strategic Opposition, finally making the walled island become invisible, disappearing forever from the Earth’s surface. Thenceforth, sleeping men would speak of Valhalla, the abode of the Siddhas, and also of Hyperborea, the “island swallowed by the sea,” since the original myth, charismatically transmitted by the Siddhas, has suffered various falls into exotericism due to the blood impurity of the Viryas.

The question that initiated the preceding esoteric commentary, let us recall, was asking “what has become of the Gral...?” In response, we found that it is erroneous to inquire about the Gral, since this virtually is *The Origin*, and has never moved from there. Its seat, on the other hand, the Rune of Gold, possesses the dimensions of a material object and it is given to suppose that, to a great extent, it is affected by the laws of physics. We can then re-pose the problem: what has become of the Rune of Gold? Is it still holding the gem of Khristos Lucifer? In this last case the answer is affirmative: the Rune of Gold has since then been the seat of the Gral, a situation that has not altered at all in modern times. With regard to the first question, we should realize that it would be an impossible task to summarize here the complete itinerary followed by the Rune of Gold up until today; it would force us to mention disappeared civilizations and, many of them, completely unknown to official culture. We will refer, then, to historical times, starting by establishing some guidelines that will allow us to face the problem in a correct manner, thus avoiding many superstitions or disinformations.

1. The Rune of Gold has been many times confused with the Gral. Indeed, we have already explained why the Gral should not be sought. However, on some occasions there really has been a transportment and it has been thought, with reason, that it was the Gral. *But the Gral is not an object of which one can appropriate, and still less manipulate or transport.* With all verisimilitude, what has been transported is the Rune of Gold, in the framework of a racial Strategy. In this case we cannot attribute the confusion solely to the enemy strategic action because, in the degradation of the ancient Hyperborean myths, the ma-

for responsibility falls on the blood impurity of the Viryas.

2. The presence of the Rune of Gold among the members of a community of Hyperborean lineage has the virtue of favoring charismatic bonding and legalizing the conduct of its leaders.
3. The presence of the Rune of Gold is the presence of the Gral; and the people to whom the Siddhas have entrusted its custody are *undoubtedly*, at this time, the purest Hyperborean lineage of the Earth.
4. In order to certify if a determinate people have been in possession of the Rune of Gold, one must study their Hyperborean war architecture:

The possession of the Rune of Gold requires the construction of stone structures with peculiar topological properties. Said constructions may *not seem* made for war, but such an appearance is exclusively due to the ignorance that exists about the Hyperborean Strategy. An example of this is the “castle” of Montsegur, on Mount Pog, in the French Languedoc. This construction, which is not a fortress by any means, was erected in order to enable the Hyperborean sect of the Cathars *to receive and preserve* the Rune of Gold. The principles that predominate there are those of the “law of the fence” and of “Strategic Opposition,” it being a useless task to pretend to make of Montsegur an astronomical observatory or a solar temple. But as the architecture of Montsegur has been designed *based on* the Rune of Gold, whoever does not take this key into account will never arrive at any positive result.

5. One must distinguish between the seat of the Gral, to which we call the Rune of Gold, and the Sign of the Origin, which the Rune of Gold represents. We said that the Siddhas enchased a gold figure on the violet-blue stone and we call the whole (stone and figure), the Rune of Gold. But the Sign of the Origin, which was chiseled in Gold and enchased, possesses by itself the power to present an “affinity” with the Gral. That is why many Hyperborean lineages, which did not achieve the high honor of guarding the Rune of Gold, instead received the Sign of the Origin as a prize for their blood purity and

recognition of the effort put into their Strategy. Thus is how the Sign of the Origin had, with the passing of History, a particular proliferation among certain lineages who proudly incorporated it into their banners. Naturally, the leaders in the beginning tried partially veiling its symbolic content by simplifying the figure, i.e., removing some suggestive elements; but, after the fall into exotericism and vulgarization, *the true appearance* of the Sign of the Origin was forgotten; we already said, e.g., that the Swastika comes from the mutilation and deformation of that Primordial Sign.

However, in many cases, due to the extraordinary blood purity of some lineage, the Sign of the Origin was exhibited in full, allowing the leaders to use its enormous power in order to project the light of the Gral onto the mass of people. We could give several examples of Asiatic communities bearing the Sign, but we have at hand the case of the *Saxons*, who had engraved the Sign of the Origin on a tree trunk to which they were considering the column of the world (*Universalis Columna*). The purpose of such an audacious determination also deserves a commentary. When Charlemagne conquered Eresburg in 772, he rapidly proceeded to destroy the Irminsul trunk and to execute five thousand members of the Saxon nobility. Not content with this, after three decades of heroic resistance, the Saxon Race, of the purest Hyperborean lineage, was totally “Christianized” (after execution of its purest offspring). We have learned that many cultured Germans consider “fortunate” this dreadful Carolingian campaign. Thus, e.g., Professor Haller unblushingly opines that “without the subjugation of the Saxons there would not be a German nation today,” since “Charlemagne’s greatest and most momentous undertaking was the subjugation of the Saxons. It gave the final shape to the Frankish Reich and created essential conditions for the state and cultural development of the Western world up to the present day.”⁷⁸ This generalized opinion is based on the “a posteriori” analysis of the historical facts, and that is why, considering that the extinction of the Carolingian dynasty made it possible that two hundred years later the Saxon

78. *Der Eintritt der Germanen in die Geschichte*, Johannes Haller, 1957

blood arrived with *Otto I* to take the lead of the Western world, it is taken for granted that the domination and “conversion” of the Saxons was “necessary” and positive. Here is *our* opinion: the Judeo-Christianization of the Saxons represents the harshest blow that the Infernal Powers dealt to the Hyperborean lineages in the Christian Era, even greater than the conversion of the Vikings, of the Celts, or the destruction of the Cathars, only comparable to the annihilation of the Gothic Kingdoms. And the destruction of the *Irmingsul* tree, with the loss of the Sign of the Origin for the Occident, is a catastrophe very difficult to evaluate.

6. It is not indispensable, nor even necessary, that the Rune of Gold be found in the bosom of a people for the influence of the Gral to act upon them. The Gral acts upon the Viryas *from the Origin*, a property that cannot be affected by any physical variable, wherever the Rune of Gold is found. That is why it is, to a certain extent, absurd to attribute to such and such a people the achievement of a “high degree of Civilization” because “they were in possession of the Gral,” given that the Gral cannot be in the possession of anyone since it is, by arrangement of the Gallant Lord, proof of the Divinity *of all* the captive Spirits. What a people can have *in custody* is the Rune of Gold, but only as a prize and recognition of a *previously* attained racial purity, i.e., that the fact of having the Rune of Gold in custody is not the cause of the greatness of a people but inversely, the purity of its lineage made it worthy of the High Honor of being the depository of the seat of the Gral.

But, even though the Rune of Gold *is only delivered to those who deserve to have it*, it is true that its close presence affects the environment by creating a mutant microclimate. That is why the Siddhas usually deposit the Rune of Gold, during dark epochs, in appropriate sites in order to influence the less confused lineages.

7. From all that has been exposed up to this point, we can see the capital importance that it would have for a community of Hyperborean lineage to gain the custody of the Rune of Gold. It is then necessary to address this possibility in detail, which we will do in the next article when dealing with the A2 Strategy of the Siddhas. However, before considering the A2 Strategy, we must be clear about a fundamental concept, which is readily apparent from the preceding conclusions. The problem can be summarized in the question: why does “the King” (or whoever holds the Regal Function) need to find the Gral (that is, the Rune of Gold)? Next, let us invite a brief reflection on the attitude that one ought to adopt when taking knowledge of the events protagonized by the Siddhas, and then we will give an answer to the problem by delving a little deeper into the symbolism of the Gral.

A profound meditation on the symbols that we have presented is required in order to capture their ultimate contents, which should always be perceived as dramatic and tragic, brimming with spiritual urgencies. No one who has become aware of the incredible sacrifice made by the Siddhas in maintaining the Gral in the world for millions of years through Strategic Opposition, i.e., by a constant and continuous act of Will, no one who has realized it, we repeat, will be able to remain impassive, in the midst of the confusion, without experiencing an urgency to free himself from the chains of the Demiurge and depart, trying to alleviate, in some way, the task of the Siddhas. No one who verifies the truth of these symbols with his blood will be able to prevent Honor, the only morality of man, from insistently urging him to “abandon everything” and depart. But that departure will be “with weapons in hand,” like Nimrod and Wildejäger, prepared to fight an all-out battle against the Demons and feeling that the blood has been ignited by the “Berserker Fury,” by the “original hostility” toward the work of the Demiurge, transmuting the weak organic substance of the physical body into Vajra, the incorruptible matter. It is the least that the Virya can do in order to respond in some measure to the aid that the Siddhas have lent to the Hyperborean lineages, making it possible, with their Hyperborean Strategy, for the Gral *to give proof of the Divine Origin*.

Let us now go to the pending question.

The Gral-Stone, the gem of Khristos Lúcifer, *is sustained in the World by the Opposition of the Siddhas*, where it fulfills its function of reflecting the Origin and divinizing the Hyperborean lineages; but, *because it is temporally related to Valhalla*, it also points out, to every liberated Virya, a path toward the abode of the Immortals. That path is that which the fallen warriors in battle follow, the heroes, the champions, guided by the Hyperborean women, those who were promised to them at the beginning of time and whom for thousands of years, because of the *fear* that was poisoning their blood, they had forgotten. If the valor demonstrated in the feat has been a sufficient purge, she will, without fail, be there, next to the fallen warrior, in order to cure his wounds with the frozen A-mor of Hyperborea and guide him on the inverse path that leads to Valhalla. *And that path initiates in the Gral.*

But by this it should not be thought that the light of the Gral aims at the individual salvation of sleeping men, for that purpose the “Singing of the Siddhas” and the seven secret ways of spiritual liberation are available. On the contrary, within the “O” Strategy, the Gral must fulfill the fundamental role of *restoring the Regal Function*; that is to say: it must serve a racial or social purpose. That is why the Gral will be required in all cases in which it is attempted to establish the Universal Empire or any other system of governing based on the social application of the law of the fence (monarchy, fascism, national socialism, aristocracy of the Spirit, etc.).

The historical events that lead to the “search for the Gral,” always similar, can be symbolically summarized as follows. In principle, the kingdom is “terra gasta” or the “king is ill” or simply the throne has become acephalous, etc. (There can be many interpretations, but the symbol essentially refers to a depletion or decline in charismatic leadership and a vacuum of power, whether the government is exercised by a king, caste, or elite.) The best knights set off to “seek the Gral,” in an attempt to put an end to the evils that afflict the kingdom and ensure that the ancient splendor returns. Only one succeeds in finding the Gral and restoring well-being to the kingdom, either by “curing the king” or “crowning himself.” Curiously, the triumphant knight is always presented as “foolish,” “pure crazy,” “naïve,” but especially as a “plebeian.”

Here, the “best knights” are equivalent to any of the multiple social forces that are ready to launch themselves upon the

Regal Function when an acephaly or vacuum of power exists. Finally “one of them” triumphs and re-establishes order in the kingdom; “he was the plebeian and now he is king, with the approval and consent of the people.” In our interpretation, this means, evidently, that a “social force” has predominated over those remaining (the “other knights”) and *has replaced the existing order* (which was interdicted) by a *new order*, unanimously accepted *by the people*. But if the problem is reduced to a mere struggle for power, why does the new King (or new elite, aristocracy, caste, etc.) need to find the Gral? *Because the Gral confirms the Regal Function.*

When in times of crisis a new elite or a charismatic leader takes power, with intentions of regal restoration, he must hasten to *legalize* his situation, otherwise another elite or leader will come to question his titles and will also attempt to occupy the vacant place, thus an endless series of battles, political or military, will ensue. But if there is a struggle for power, *no one has its control*; and it may occur that in the end the kingdom winds up divided among various factions. It is necessary to settle the question, to consult an infallible judge, an undisputed and transcendent authority. Here is where the necessity to appeal to the Gral arises. Why the Gral? Because the Gral is also the Tabula Regia, the “list of kings”; *it states who should govern, to whom it befits to rule, because it reveals who has the purest blood.* But this revelation is not simply oracular and arcane but through the mediation of the Gral, the purity of the leader, his right to leadership, will be known by all and recognized by all, charismatically. Hence, the pure madman, of Hyperborean lineage but of plebeian stirp, after “finding the Gral,” is “recognized by the people” as the undisputed king.

When a Hyperborean lineage trusts in the light of the Gral for the election of its leaders, it can properly be said that a dynasty of “Kings of the Gral” will succeed one another. During the reign of one of these, it may come to pass that the lineage reaches such a high degree of purity that it becomes worthy of gaining the custody of the Rune of Gold. This is what occurred, e.g., in the thirteenth century in the French County of Toulouse, when the Rune of Gold was entrusted to the perfect Cathars. (It will be claimed, against this affirmation, that the Cathars were Manichaeans, i.e., inheritors of a Gnostic tradition, and that that is why they were annihilated, only a circumstantial relationship existing between them, the Counts of

Toulouse, and the Occitan population. Such an argument, of modern Druid origin, attempts to divert attention from the most important fact of the Cathar epic: its relationship with the Gral. The fact that they were Gnostics, which no one disputes, and that they taught one of the seven secret ways of liberation based on the Siddha's Song of A-mor, the origin of troubadour culture, which few know, does not at all explain their relationship with the Gral. The Gral, in the framework of the "O" Strategy, has a purely racial meaning. If the Rune of Gold was entrusted to the Cathars, it is because they were actively participating in collective techniques of transmutation, *which cannot exclude the Regal Function*, and not simply "because they were of a Gnostic affiliation."

A theme connected with the property that the Gral possesses, of being a Tabula Regia, is that of the Imperial Messiah and its imitation: the Jewish Messiah. In principle, we will say that one is King of the Gral by purity of blood, an absolutely individual attribute that depends neither on race, nor on stirp, nor on any other material patrimony. A King of the Gral exhibits purely personal virtues such as valor, intrepidity, or honor and never fundamentals his prestige on material possessions or on the value of gold. The authority of a King of the Gral, for these reasons, exclusively comes from his personal charisma, which extends itself to the rest of the people thanks to the "bonding" that is established between the King and *each one of them*, in their blood, *through the mediation of the Gral*: it is the principle of the psychosocial Mystique. That is why a King of the Gral, *in his community*, is recognized by the people. Naturally, *all peoples* would have their King of the Gral if the action of the Synarchy and the Hebrew Race, with their "democracy," "socialism," "communism," etc., had not usurped the Regal Function. In any case, it is worth asking: would the Hyperborean lineages, at a universal level, have the possibility of a King of the Gral that was recognized by all? This would be a personage of undeniable purity, whose majesty would be evident to all the lineages of the Earth, those who may or may not accept his authority, but to whom they would not be able to deny his right to rule. Well, it is easy, then, to respond that the only Lord that accredits, for all the Hyperborean lineages, such a right, is Khristos LúCIFER. If He were to present Himself

before the Hyperborean lineages, His right *to rule by blood*,⁷⁹ based on His undeniable purity, may or may not be accepted, but never denied.

But the idea of an Imperial Messiah does not come from a mere speculation. It was in the black days of Atlantis when, in response to the clamor of the Siddhas, the possibility arose for the exalted Presence of Khristos LúCIFer to be manifested to the sight of men. In those days, the confusion of the captive Spirits was so complete that no one was any longer responding to the Singing of the Siddhas or was capable of perceiving the light of the Gral. That is why the coming of the Imperial Messiah, the Gral's King of Kings who was going to restore the Regal Function in order to re-establish the spiritual aristocracy of the Hyperborean leaders and destroy the synarchic Hierarchy that the Demons were imposing, was announced for centuries. The prophecy was finally fulfilled with the arrival of LúCIFer, the Khristos of Atlantis; but his Divine Presence was cowardly resisted by the Demons of Chang Shambhala who resorted to black magic and opened a breach between the infernal regions of the astral plane and the physical plane. From there, a terrible conflict was generalized, which only concluded when the continent of Atlantis "had sunk into the waters of the Ocean." It is pointless to recount events here that today no one remembers and that, perhaps, are not worth remembering. We will only add that when the Demiurge, as we already explained, conceives the sinister idea of copying the Presence of the Khristos of Atlantis, He also decides to "announce" the arrival of a "Messiah" by imitating, in His own manner, the figure of the Imperial Messiah. But the differences are enormous. Here are some:

1. The Imperial Messiah comes to restore the Regal Function; the Hebrew Messiah comes to exercise the Priestly Function.
2. The Imperial Messiah accredits his right *through the blood*; the Hebrew Messiah accredits his right *through the heart*.
3. And that is why the Imperial Messiah will be recognized by the people *through the blood* (charismatically); and that is

79. It never hurts to repeat that we refer to another blood distinct from the physical. Until a better explanation is available, it is convenient for the reader to take this "blood" in a symbolic sense.

why the Hebrew Messiah will be recognized by the people (Judaized) *through the heart* (emotionally).

Let us pose a question: what has become of the Gral and its imitation, the Tablets of the Law? We provide several elements that contribute to its answer. In summary, we have said that the Gral, from the Origin, still rests on the Rune of Gold, and we mention that the latter was given in custody, in the thirteenth century, to the Cathars of the French Languedoc. What has become of the Rune of Gold since then? This is what we will try to respond in the next articles when presenting the A2 Strategy of the Siddhas. And about the Tablets of the Law, we said that they remained for twenty-one centuries buried under the ruins of Solomon's Temple, in Jerusalem, where they were found in the twelfth century. We will also talk about this discovery and subsequent fate in the next chapters.

The "O" Strategy is a "general" or totalizing strategy; the A1 and A2 Strategies are "partial" or field strategies. The A1 Strategy, which at first we attributed to John Dee and Wilhelm von Rosenberg, and which in truth was designed by them, as we have seen in the previous chapter, was finally connected with another field strategy, much earlier, thanks to the roll of Genghis Khan. This other strategy, which we have called "A2" for the sake of simplicity, is carried out *in History* until the middle of the thirteenth century. From that moment on, it is no longer in effect (for having failed to achieve its objective) and only in the seventeenth century, with the A1 Strategy, that *some of its patterns emerge on the surface of History*. We must note very clearly that the "O" General Strategy, which is esoteric and transcendent, differs fundamentally from the A1 and A2 Partial Strategies, in that the latter are dynamically directed toward *influencing History*. In other words, the A1 and A2 are strategies that attempt to divert social variables "in the long term" in order to force the restoration of the Regal Function; they rely, for this purpose, on the action of Hyperborean leaders who charismatically guide their peoples against the synarchic plans, using war if necessary. These strategies, then, are related to that "racial and collective" part of the "O" Strategy, i.e., with the functions of the Gral. The A2 Strategy, especially, has had to do with the last historical destiny of the Rune of Gold, as we will see next.

SECOND DISSERTATION

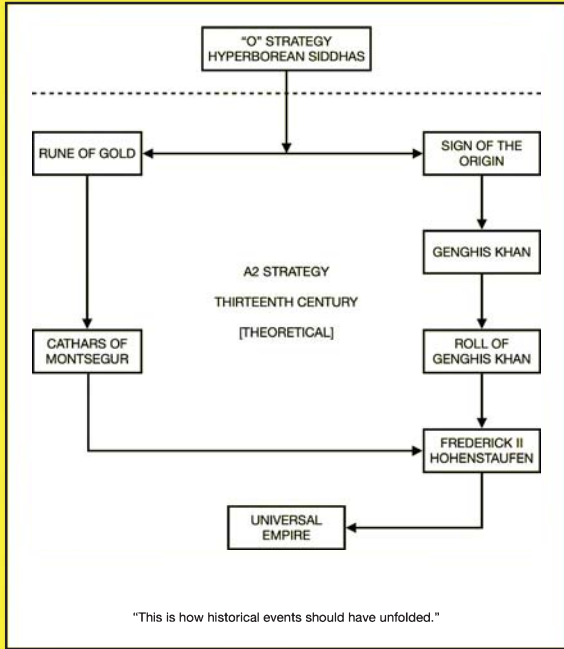

Figure 1

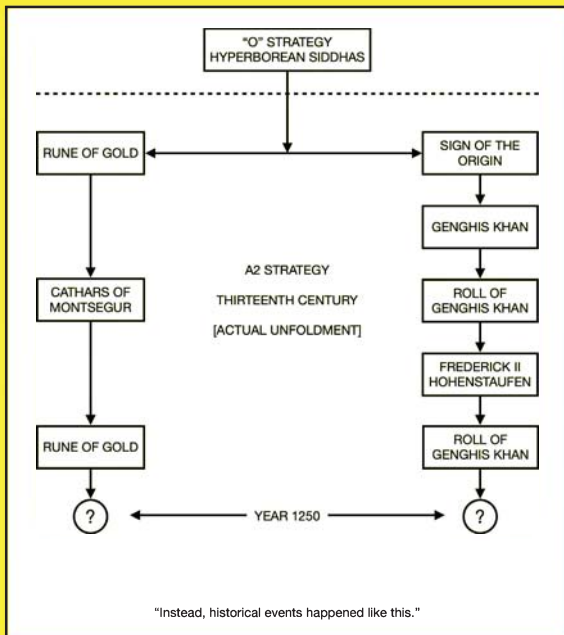

Figure 2

In order to interpret, without misunderstandings, the role that the A2 Strategy has played in History, on which we are now going to elaborate, we have synthesized the principal storylines in a few graphs. Figure 1 shows how events would have unfolded if the A2 Strategy had triumphed; Figure 2 expresses, on the other hand, the actual strategic situation in the year 1250. For the time being, we will dedicate ourselves to comment on the A2 Strategy by referring to such figures and later on, when the A1 Strategy's turn comes, we will use other equally synthetic graphs.

Introduction to the A2 Strategy



efore considering the concrete facts that constitute the development of Strategy A2, it will be useful, as we have done in other parts of this work, to first present some concepts of the Hyperborean Wisdom that will facilitate the comprehension of the subject.

If Figure 1 is observed, it can be seen that the “O” Strategy has impulsed two “lines of action”: one, clearly Western, is initiated with the delivery of the Rune of Gold to the Cathars of Montsegur for its guardianship; and the other, Asian-Western, begins when Genghis Khan receives the Sign of the Origin. This second line, and in general the whole A2 Strategy, are founded on a principle of the Hyperborean Wisdom concerning the mission that corresponds to the Mongol peoples in History. We must then know this principle and also define what is to be understood by “Mongolian peoples.” But that is not all: in knowing the mission of the Mongols, we will wonder about the true meaning of the name “Kaly Yuga,” with which the current era is called, and such a question will force us to reflect at length on the modern concepts of “Historical Age” and “History” before arriving at a definition that clearly expresses the Hyperborean concept of the Kaly Yuga.

These and other matters of similar importance will be the object of the Introduction. At the conclusion of it, the facts involved in the A2 Strategy will be briefly narrated, which will be, thanks to what we have seen here, easily understood.

1) By “Mongols,” not only should a racial community of defined ethnic characteristics be understood, but also those peoples who, possessing such ethnic characteristics, have inhabited the territory of Mongolia since ancient times, i.e., in that desiccated sea between the Altai, Khangai, Sayan, and Tannu-Ola mountains and the Gobi desert to the southeast. With this criterion will also be considered “Mongolian” those ethnic groups that would have left, through emigration, their primitive settlement in Mongolia, e.g., the Huns, Bulgars, Turkmen, etc.

The necessity of linking some “Yellow” peoples, often nomadic, with a certain territory in order to consider them, just now, as “Mongolians” comes from the particular importance

that the Hyperborean Wisdom assigns to a vast region of central Asia, which is often loosely identified as “Mongolia.” In effect: in Mongolia lies the *Kaly Yuga’s center of lesser intensity*, a concept we will explain later on. But we can now state that it is by virtue of the “geochronological” quality of Mongolia that the peoples coming from its confines always perform significant movements for the History of humanity. Mongolian origin, that is to say, the fact of coming from Mongolia, is a fundamental sign in order to comprehend the Strategy of the Sidhas, therefore:⁸⁰

2) *The mission of the Mongols in History is to “push” the Hyperborean lineages of White Race “toward the Kaly Yuga.”*

3) Without an adequate clarification the “2nd” statement will not be understood, for there is a widespread confusion between the Western concepts of “History” and “Historical Time” and the ancient Eastern (?) concept of “Kaly Yuga.” Whoever understands the Kaly Yuga as a simple “historical period,” in the Western manner, will surely find the statement that the Mongols must “push” “toward the Kaly Yuga” meaningless; but, as we said, this is the product of confusion.

First of all, how much does the Kaly Yuga period represent in chronological time? Although there are differences, according to the interpretation of the Hindu sacred texts by one or another school, we can take as acceptable the number that Rama Prasad gives: 438,000 years.⁸¹ Where does this number come from? From a complex mixed system of division of time that, in the part that interests us, says:

12 months = 1 Daiva day and night = 1 year = 365 days, 5^{hr}, 30', 31"
 365 Daiva days and nights = 1 Daiva year
 1,200 Daiva years = 1 Kali Yuga.⁸²

Therefore, a Kaly Yuga is equal to 438,000 years (1,200 × 365). As might be expected, the Kaly Yuga begins in the Atlantean

80. This clarification is necessary because otherwise all members of the Yellow Race (Chinese, Japanese, Tibetans, Burmese, Siamese, Malays, Polynesians, Maoris, Turks, Turkmens, Bulgarians, Magyars, Lapps, Finns, Samoyeds, Kyrgyzs, Ostyaks, Eskimos, etc.) would be considered “Mongols” and this is not our view, as will be seen.

81. In the “Fundamentals,” a more reliable number of 432,000 years is given.

82. *Nature’s Finer Forces*, Rama Prasad, Theosophical Publishing Soc., 1894; p. 13.

epoch, at that time when the Traitorous Siddhas install themselves at the head of Atlantis' civilization, where they would be known as the "Siddhas of the Dark Side." But that is another story. We now know that a "Kaly Yuga" is an extremely long period of time; but, is it only a "period of time"? What does the name "Kaly" attached to "Yuga" (which *does* mean "period of time") mean then? In order to respond with clarity we will resort to some ancient concepts that are by no means unknown in the West, but that modern Historiology has left aside or, if the terms were useful to it, it has used them by perverting their meaning. This is what happens with the word "Age" of Greek mythology (of gold, silver, bronze, and iron), which has been emptied of its primitive conceptual content and used in a profane manner in order to designate arbitrary parts of official "History": "Ancient Age," "Middle Ages," etc.

4) Besides the fact that official "History" encompasses a ridiculously short period of time, seven or eight thousand years, in relation to the antiquity of millions of years that the human species presents on Earth, the "Ages" into which it is divided have only the objective of pointing out certain intervals between "important" events for the mnemonic convenience of historians and pedagogues; for example, the Middle Ages "begin in 476, when Odoacer deposes Emperor Romulus Augustulus, i.e., with the fall of the Roman Empire" and ends "when the Turks take Constantinople, in 1453"; from that date extends the "Modern Age." This way of "marking" the limits of the "ages" reminds us of the geographical demarcation of borders, which generally exists only in the minds of men and on maps: on the ground, at times, there is nothing that indicates that such a country ends here and such another begins beyond, an uncertainty that does not prevent one from blindly believing in "the border" as something existing in nature for which it is possible (and desirable) to fight and die. Let it not be said that a river, e.g., constitutes an "actual" boundary; a river is just that: a watercourse, a geographical feature; any cartographic property attributed to it comes from a gnoseological error, from forgetting that a "geographical limit" is a convention between men, such as the symbols of language and that, because of said symbolic character, belongs to the collective psyche, i.e., to the subjective sphere and not to the objective reality as we might hastily believe. Cartography consists in graphically

representing signs corresponding to the configuration of the Earth and its features; the map, then, possesses a certain relationship with a territorial reality, but such a relationship is *univocal*; in other words: it is true that that line on the map represents the bank of that river; it is not true, however, that by painting that line with a determinate color in order to “represent” a border it corresponds to some quality of the considered territorial reality. Just like those who believe in the concrete reality of a cartographic border, which only exists on maps and in their imagination, there are many people nowadays who naïvely accept the division by “Ages” of History and even give themselves the luxury of making valuative judgments: the Ancient Ages were “pagan,” the Middle Ages “dark,” the Modern Age “brilliant,” etc. Evidently we are here in the realm of cultural subjectivism, since neither History has developed on the basis of such “Ages” nor are the events that determine the interval of each “Age” true historical milestones, more important than other events that occurred before or after them. The events that “mark” the beginning or the end of an “Age” are chosen, from among the infinite number of other events that make up History, in order to form a pattern established prior to the analysis, i.e., a hypothesis. This supposes that some “particular criterion” has been resorted to for the interpretation of History, which explains the subjective character of the obtained conclusions.⁸³

If such a criterion consists, as seems to be the case of the official “Ages,” in considering Economy and War as a fundamental parameter, then it is *logical* to set the limits of the interval in wars and battles or in the economic ruin of the Roman Empire. But if the criterion were another, for example philosophical, aesthetic, technological, etc., surely the “fundamental facts” that mark the limits of the Ages would also be others and even the valuative judgment of them would notably vary. For example, the end of the Middle Ages is fixed with a “political” criterion in 1453, when the Turks take Constantinople and the Eastern Roman Empire ends; this is a negative fact that has been deliberately chosen to mark, consequently, the end of a “Dark Age.” But for a positive scientific-technological criterion, the invention of the movable-type printing press by

83. The “criteria” are logical guidelines that inevitably appear in any rationalist consideration.

Gutenberg in 1450, i.e., almost at the same date, would undoubtedly be more important than the fall of Constantinople. It could then come about that the Middle Ages would end on the same date but, by taking a positive event as a limit, the value judgment would have to be modified. Perhaps then the Middle Ages would not be “dark” but “transitional,” considering that in order to reach the German invention of the printing press, a previous cross-cultural contact with China had to be established in the fourteenth and fifteenth centuries.

We have been verifying the subjective character of the modern concept of “Age” and the flimsiness of those “fundamental facts of History” that are taken as “limits” of the covered time interval; these facts have been chosen on the basis of cultural criteria, often synarchic, and are presented after a previous deformation of the historical truth; thus, a change of criterion leads us to different “fundamental facts,” more or less displaced in time, which demonstrates the insufficiency of the concept of “Age” for designating an Era of alleged specific characteristics.

We must suppose, then, that what official history describes to us in a determinate “Age” possesses a distorted relationship with the concrete facts to which it makes reference, in a manner similar to the subjective alteration of the true facts carried out by historians in order to present them as limiting-facts.

This supposition can be rigorously verified if we once again resort to the cartographic analogy and use the already defined concepts of “the eminent” as “the enhancement of a quality, rationally exalted by the determination of preeminent cultural premises. Let us observe a map of Europe; on it the different countries, their interior political divisions, and their exterior borders have been represented by means of signs known to all. Suddenly we set our attention on some sinuous lines that inform us that in the corresponding part of the world some mountains must exist; we read an indication that says “Pyrenees Mountains” and we think, “Ah, it is the border between France and Spain.” We know this because that information is a common cultural domain. If we now attentively seek among the different lines of the map, an area marked differently, perhaps with a different color or perhaps with lines and dots, will become eminent, which we will distinguish as “the border” itself. The preeminent cultural premises made the borderline eminent among many other similar lines and led us to discov-

er and recognize it. But, as we have said, the border exists only on the map and in our imagination, which can be verified by situating us in certain deserted zones of the Pyrenees Mountains from where it would be quite impossible for us to decide where Spain ends and France begins.

We have taken knowledge from the map of two datums: at such a place in the world, the coordinates of which enable us to precisely identify, there is a mountain and a border. We actually move to that place and find the mountain but we have difficulties in distinguishing the border: what has occurred? A mountain and a border are realities of a different order. That is why there are two classes of maps: the “physical” ones, which more or less faithfully describe the geographical reality, and the “political” or “economic” ones, which exhibit, *in addition to* the corresponding physical representations *superimposed on them*, qualities and attributes that do not possess a concrete counterpart in the world. Both a mountain and a border are cultural objects; but the mountain is a concrete object of natural substance, whereas a border (like a myth, a scientific idea, a political organization, a moral code, etc.) is a cultural quality that will never totally appear incarnated in a concrete, physical, or “exterior” entity.

To perform Historiography, to write History, is analogous to the construction of a map, *to describe a reality*. History, in narrating true facts of the past, has at its disposal purely objective material, the description of which it presents in symbolic language for our information. But the historiographer, like the cartographer, counts on two types of objects: the actually occurred “facts,” which have been concrete objects, and the “eminent facts,” taken from among the other infinite facts, because of their subjective importance. But the eminent facts, as we already know, are determined by preeminent cultural premises that are, in the end, the tactical expression of Culture, the enemy strategic weapon. Thus, if when studying History we note that the facts described are presented to us with a certain objectivity, we are, as in the case of the “physical map,” facing a more or less direct and undeformed representation of reality. But when one claims to affirm an eminent quality in a concrete fact, for example when it is said that the French Revolution was “superior to other revolutions because of its progres-

sive character,”⁸⁴ we are, as in the case of the “political map,” facing a representation of cultural qualities without a material counterpart.

An eminent quality in History, like a border on a political map, is an object that belongs to a sphere different from the concrete reality; its eminence comes from preeminent cultural premises: Hannibal or Publius Cornelius Scipio? Sparta or Athens? If History presented the facts just as they occurred, the preference that we declared for such a military leader or for such a culture would indicate that that military leader or that culture had become eminent before our eyes. But this is not possible because the History that we have available for our study is in no way objective or descriptive of the reality of the facts, since the Historians of all times have been victims of their own preeminent cultural premises and have singled out eminences wherever they appeared to them, attributing to the concrete reality qualities that were only in their imagination, i.e., projecting on the world cultural qualities that were not possessing a concrete substance and then perceiving the mirage of their reflection. That is why the official History is tainted with an unreality and should only serve to any investigator of Hyperborean lineage as a mere reference, a pale reflection of the truth.

History, after it went through the “synarchic-strategic treatment” of the cultural patterns of Judeo-Christianity, is a minefield in which any unwary person can get lost and perish. Its cloaked objective is to provoke confusion, the cultural conditioning of “modern man”; that is why it will tell us or induce us to declare that the Athenian civilization was superior to the Spartan, that the religion of Jesus Christ put an end to the savagery of the pagan cults, or other similar absurdities.

It is now time to again refer to the “Ages” of official History. It will become evident, after what we have seen up to here, that the modern concept of “Age” is only an arbitrary interval of time, marked at its extremes by certain eminent facts for historians, who, undoubtedly, are conditioned by preeminent premises (which are, definitively, synarchic guidelines unconsciously assimilated by them). In order to verify it, it is enough to refer, e.g., to the nearest limit of the Middle Ages, noting

84. The “superiority” that we value of one thing over another is an eminent quality.

that the fall of Constantinople has been eminent for the majority of “historians,” over other contemporary events, among which the invention of the printing press stands out, just as we said.

This long critique should have clearly shown us that an “Age” of official History is a cultural object conceived from a subjective view of History, limited by eminent facts that are deformations of the true facts. But such an “Age,” as a sum of eminent facts, is an extreme example of a concept that keeps a distorted relationship with the concrete reality of the historical facts that it represents. That is why the modern concept of “Age” possesses almost no content; it is a hollow shell that is barely enough to cover some synarchic lies. Justly, our immediate task will be to endow the word “Age” with a new content, which in truth is its ancient significance, for later on we will have to use it to define, or redefine, the concept of “Kaly Yuga.”

5) Contrary to the modern criterion, the ancient concept of historical periods that the ancients were having, was not started by man, but by God. Of course, as History was being conceived as a cyclical succession of Eras that were being born and dying like the vital cycles of nature, not one God but a multitude of Gods were coexisting, peacefully or not, in the heavens of Antiquity. In truth there was a God for each Era, i.e., one who was predominating over the remaining deities and was capable of irresistibly exercising His power over the world and men.

The major period was the “Age” (or the Yuga) that was comprising several Eras or human stages of specific characteristics and, naturally, was presided over in all its chronological length by a superior God whose influence, also cyclical, was beginning and ending together with the Age in question. The duration of an Age was corresponding to the manifestation of a God; when it was reaching the end of such a period the God withdrew, but not without first sustaining a harsh struggle with the succeeding deity, ceasing, from then on, His influence.

Nowadays it is a common opinion that “the Gods die when their Age of predominance ends,” adducing various reasons to justify the fall of the deity: “men forgot him”; or there was “no such God” at all; He was a myth, and when “progress,” or “evolution” led men along the path of civilization, they “woke up”

and proceeded to replace their false and superstitious convictions with rationalistic ideas that perfectly explain the unfolding of the Universe without resorting to any divine intervention”; etc. Against this opinion, the Hyperborean Wisdom affirms that an Era concludes when the God (or the Myth) ceases to manifest His influence over the whole of men. The Aztec Era concludes when the Spaniards replace the bloody cult of beating hearts with the cross of Jesus Christ; but it is also true that Huitzilopochtli had abandoned the Aztecs long before, just as Princess Papán told Moctezuma and just as he himself verified, given that besides being emperor, he was a high priest of the cult of the Hummingbird God.

History informs us that there were Eras in the past during which men adopted particular religious beliefs and cultural styles. Since every Era is ruled by a God, it is worth asking: what has become of those deities whose influence was dominant in past Eras? The answer is not difficult, since History also gives us news on such a question: to each past Era corresponds a myth of which Tradition and documents give an account. At one time in Rome, Mars reigned and at another Jupiter, Greece knew Eras of Apollo and Zeus, Egypt shone fleetingly under Amon and was feared in the Eras of Osiris and Isis, Carthage became audacious in its Era of Moloch, etc., to give only a few examples taken from recent civilizations. In these examples, and in many others that could be provided, it is shown that the preceding answer is correct: we know about the God of a bygone Era from myths and legends that have reached the present day. This is the answer that History gives us. We will add the following, and this must be affirmed: *“myths” are effectively the current expression of the ancient devalued Gods.*

Of course, to understand this statement in all its depth, we must resort to C. G. Jung’s concepts of Analytical Psychology, which assure that an ancient myth survives as an unconscious content of the collective psyche. In the “Fundamentals” this theme is extensively elaborated and the word “myth” is defined for a “dead” or devalued God, and “Myth” for a dominant or active God. But the important thing now is to keep in mind that according to this theory, Gods do not really die, but rather their disappearance, their invisibility, is due to the fact that they have been incorporated into the collective unconscious of their cultures, momentarily or definitively losing sight of

them. In this sense the myth is identified with a certain type of collective archetypes, i.e., common to a whole race, the characteristics of which are inherited and constitute an unconscious content of the human psyche. It should not be believed that this psychological concept implies the invalidation for the God to act exteriorly (in a psychoid manner) just as tradition informs us that all the Gods act. There is a contact between the personal collective unconscious and a “universal collective unconscious,” which is the very substance of the Demiurge, the plane where He has deposited the Archetypes of His creation: by an interaction operated directly in the deep unconscious of man, the leveling or equalization is carried out that makes a myth a “Myth,” i.e., the process by which a passive structure (the myth) is transformed into a dominant entity (the Myth) fed with energy (libido) subtracted from the psyche. This important issue will also be studied in depth in the “Fundamentals.”

Myths are always present in all peoples and in all circumstances. Their passivity does not mean that they have died, for they could “resurrect” and once again become Gods, as in fact has occurred many times, according to the convenience of the Demiurge, since the Gods are, as it has already been noted, expressions of His psychoid Archetypes. We will not go into detail about the Demiurge’s Plan and explain the need for Him to project Manu Archetypes upon humanity in order to direct the evolution of life and of form. We will only add that a Manu, the “idea” of a race, is the dominant psychoid collective Archetype, the God of an Age; but a Manu, it is important to never forget, is an unfoldment of the Demiurge Himself, a “divine appearance” devoid of individuality; if a God “appears” it is because the period of its unfoldment is too long for it to be discernible to an incarnate Spirit, enchained to an incompatibly short vital period; lastly, a Manu unfolds in a Hierarchy of intermediary entities, who receive the mission of carrying forward certain parts of the Plan: these entities, together with some members of the devic evolution and the “evolved” Paśus or adepts, make up the White Hierarchy of the Traitorous Sidhas.

Using these concepts we can now redefine, in modern terms, the ancient idea of an Age. Let us go from minor to major:

- a) Any historical circumstance is the conjunction of humanity and certain Archetypes to which the former is subordinated by evolving toward the latter's perfection.⁸⁵ Also:
- b) A historical Era is the conjunction of a cultural community and of a God to whom the former is subordinated and whose Will obeys the latter. (Or, expressed in modern concepts: a historical Era is the conjunction of a cultural community and of a collective Archetype to which the former is subordinated and toward which the former's culture evolves the concretion of the latter.)⁸⁶
- c) A historical Age is the conjunction of humanity, during such a period, and of a Manu Archetype to which the former (humanity) is subordinated by evolving toward the latter's (the Manu Archetype's) perfection. (In this definition the concept of Manu Archetype involves the entire Hierarchy that participates in the Plan.)

The previous definitions may provoke a doubt that we will immediately clarify. The question would be the following: if we have rejected the Modern concept of "Age" for considering it synarchically conceived from preeminent cultural premises, what sense does it now make to revalue the ancient concept if it expresses that "an Age" is the duration of a Manu Archetype incarnated by the Demiurge? Are we not once again in enemy territory? Such objections have a fundament and that is why it is worth clarifying that, although both concepts of Age are insufficient and synarchic, the ancient one, although it makes reference to Manu, will serve us to explain the also ancient concept of "Kaly Yuga"; because, it is worth affirming, "Kaly Yuga" is indeed a Hyperborean idea, on which have been poured mountains of confused opinions and that we will have to redefine in order to reveal or approach its Mystery and render it intelligible to a modern mentality.

The conceptual advantage that definitions "a," "b," and "c" have over the dogmas of official historiology fundamentally lies in the fact that such definitions allow us to confront the historical fact considered in its ontological integrity, while the same fact, described according to the official guidelines, is in-

85. A similar definition was proposed by André Nataf in *Le miracle cathare*, 1968.

86. The cultural community is subordinated to and obeys a God or collective Archetype in order for the latter to reach perfectionment or entelechy.

evitably mutilated in its metaphysical roots. It is in our interest that this difference be clearly noticed before going deeper into the significance of definitions “a,” “b,” and “c,” and that is why we will now point out the principal cause why the official descriptions of the historical fact are insufficient and partial. We can advance that said cause comes from the confusion between “historical fact” and “natural fact,” but, as such confusion is due to a typical case of gnoseological blindness, establishing the distinction between both concepts will require a long explanation.

It is presumable that the greatest error committed by a historian is that of not distinguishing that a historical fact is categorically different from one that occurred, e.g., in a remote jungle, having as protagonists members of the animal kingdom, such as a fight scene between two lions, the brawl, with all the drama that it may entail for a sensitive observer, is a “natural fact” that has taken place with indifference to human existence and that develops under the impulses of a dynamic that is proper to it. The driving force of that dynamic may not be evident to man because it is exclusive to the natural fact, because it is circumscribed to the ambit of its effectiveness. Not even intervening in the scene can do more than disturb the forces and, in an effort to re-establish their natural development, the dynamics of the fact react against the interference; it may occur that the lions devour the observer and then continue with their combat or that the latter destroys the protagonists with a weapon, or a thousand intermediate variants, but *forming part* of the scene will never be achieved; man will always be alien to the natural fact and, therefore, he will never be able to come to know it totally.

This impassable gnoseological barrier forces that a natural fact be described from the image that man perceives in his position as a pure observer. From that distance, it is inevitable to deal with appearances or partial aspects of the fact and that is why it is licit, up to a certain point, to exhaust methodological efforts that lead to the most complete possible description of the natural fact. This is what science does when it proposes to increase the knowledge available about a phenomenon: first it submits it to observation, trying to cover all possible aspects, even breaking down these aspects in order to arrive at its qualitative constitution and proceed to its *description*; if the senses prove insufficient, i.e., if the phenomenon exceeds the sensori-

al framework, the “technique” will allow to design the instruments that broaden the spectral framework of observation and reach those farthest limits of the phenomenon’s reality; finally, all the information obtained is gathered and interpreted, elaborating a theory, which, given the process of disintegration to which the phenomenon has been subjected and taking into account that a large part of it must have escaped observation, will always be impotent to present an integral explanation that allows us to comprehend the phenomenon in its totality. Of course, in a civilization where science proceeds in this way, man and phenomenon constitute opposite realities. And even if the former manages to obtain as much knowledge of the latter as to elaborate theories, and even if these turn out to be sufficient to develop technologies, the gnoseological gap not only remains open, just as it was when the phenomenon was first submitted to observation, but threatens to become wider and wider due to the dogmatism with which the well-known theories are affirmed without taking into account their errors and deviations. But that is another problem.

The phenomena, or natural facts, are investigated with the same scientific method and described in theories that, as we have seen, are insufficient to encompass their complete reality. For this reason, of a cultural fact, we can only know some partial aspects of its appearance, and there is no reason to be too preoccupied about it. But different is the case of the historical fact in which man not only participates as a protagonist but, fundamentally, constitutes its concrete support. Thus man is not “alien” and that is why it is not licit that he uses the same method with which he observes the natural facts in order to contemplate a reality in which he is inserted as an immediate actor. If such a thing is done, and in fact “it is done” in official historiography, it signifies that a false distance has been taken with the illusion of converting a fact, of which one is the inevitable subject, into an “object” under observation. But if the theory of a natural fact succeeds more often than not in diverting us from the truth of the fact that it tries to explain, the theory of a historical fact, elaborated without heeding these objections, can lead us to the antipodes of its truth. We will be able to verify this last suspicion by deepening now, in this sense, our conclusions presented in the “Ages” of official History.

In the first place, historical facts are described in an official "Age," highlighted according to the eminence that they have had for the historian, presenting them as accidental events of which sole determination, if any are suggested, obeys purely physical causes. If a historical fact keeps some relationship with another, it is affirmed that its nexus consists of certain "dynamic variables" (the economy, the class struggle, religion, war, the "dialectical movement," etc.), completely exterior and inconsistent in order to justify by themselves the genesis and evolution of the fact. Ignored here, as in the case of scientific investigations of phenomena, is the structural relationship that the described aspect keeps with the rest of the elements that make up the totality of the fact. Official History, by affirming some particular elements of said structure (the variable such and such), can only expose partial aspects of the true facts, apparent images behind which the truth of what happened is hidden. By operating in this way, a historical fact or an Era are presented to us from their most evident side (the appearance), that is to say, more crude and material, affirming, as efficient causes of their determination, some of the famous "dynamic variables" that can only be done at the cost of cutting off the metaphysical extensions that every historical fact possesses according to the definition of "a." Let us look at an example of this rationalist obstinacy: it was of no use that Alexander the Great himself declared that he was initiating the conquest of the world on the advice of Zeus; for the modern "historian," Alexander, a member of the human *species* and of the Greek *civilization*, belonged to the military *class*, to the conqueror-*type* and to the *group* of believers; Zeus, on the other hand, is only a deity that makes up *the whole* of the Greek myths. If we reflect on the "scientific" attitude adopted in presenting a historical fact classified "by parts" we will see that it has been taken as an "object of observation" and therefore confused with a "natural fact," such as an eclipse or the annual migration of swallows, i.e., with events from which determinations man is absolutely excluded. Let us follow the steps that the modern "historian" has taken. First, a fact in the life of Alexander the Great (his decision to conquer the world at the behest of Zeus) is framed in the category of "casus belli, casus dementiae" i.e., an "act of war, act of madness"; then we proceed to break it up by separating its parts to which will be classified one by one according to taxological guidelines, pi-

geonholing them into sets, classes, groups, etc.; finally, the fact is reconstructed on the basis of those parts that the official criterion considers most important or representative (an authentic theory is elaborated) and presented to the public for their consumption. Just as we announced, it is verified that after the historiographic operation only a partial aspect of the phenomenon is shown to us, but this aspect is the most paltry: because it describes the fact disconnected from its metaphysical driving force, Zeus, who in the fourth century BC was a dominant Archetype, a God, and not a mere “myth.”

We have thus demonstrated the insufficiency of the modern, rationalistic methods applied to the interpretation of the historical fact and we have indicated the error that is committed when proceeding to analytically break it up and integrate it by rational synthesis: the investigation of the historical fact is faced in the same objective way with which natural facts are treated.

But the historical fact is not, like the natural facts, the objective presence of an evolutive process, the unfolding of which man can only witness as an observer. In the historical fact, even in those that have occurred thousands of years ago, man, of whatever epoch, is always a “subject” *because the historical fact is, above all, a cultural fact.* This identity is tremendously important because it fundamentals the superiority of definitions “a,” “b,” and “c” on the modern concept of “Age” based on the rational analysis of historical facts. We will see this as soon as we define what is to be understood by “culture” and “cultural fact.”

Let us remember conclusion 7 of the “imprisoned ego” allegory, i.e., the ego of the lost Virya, which we studied in the previous chapter.

– 7 –

c) The “prison” is analogous to the “cultural structure.” Also: certain parts of the “prison,” walls, moats, bridges, etc., are analogous to certain parts of the “cultural structure,” this is, the “preeminent cultural premises.”

Commentary: Keep in mind that, in the allegory, both the “guardians” and the “prison” are intermediaries between the prisoner and the exterior world. But the “guardians” are “dynamic” intermediaries (analogously to “reason” in the lost

Virya) whereas the “prison” is a “static” intermediary (analogously to the “cultural structure” of the lost Virya).

On the other hand, in conclusion 8, the following was affirmed:

– 8 –

c) The “exterior world” beyond the prison is analogous to the “exterior world” beyond the “cultural structure” that subdues the ego in the lost Virya.

From these analogical conclusions the following definition follows: “Culture is an ‘intermediary world’ between the ‘ego’ and exterior reality.”⁸⁷ But this “world” surrounds the ego in such a way that, except for the Vril-center, all paths to exterior reality must inevitably pass through it; culture truly “imprisons” the ego within the boundaries of its environment. Let us go a little deeper into this general definition of culture as an intermediary world.

In the first place, this intermediary world has a clear biological origin; for it is evident that between every exterior reality and the ego is always interposed the structure of the nervous system (neurophysiological). But culture, like the “prison” of the allegory, is a “static-internal structure,” the “elements” of which are the preeminent cultural premises. Such elements are rigidly linked to each other by being recorded in the memory of the brain and subjected to the neurological mechanisms of interaction. Thus, there is a biunivocal relationship between culture and brain structure or, in other words: there is a biunivocal⁸⁸ correspondence between culture structure and brain structure. Now then: the structure of the brain possesses neurological mechanisms capable of establishing bioelectrical

87. We reject, therefore, the vulgar idea of “Culture” as “the collective product of human activity” or other definitions that situate the sphere of culture in the “physical world,” i.e., in the world of “exterior cultural objects.” Here we place Culture in the ambit that it corresponds to: that of the psychic reality.

88. We use the term “biunivocal” in a restricted sense: here it means the “two-way correspondence” of structures and in no way implies a mathematical homeomorphism. It is only a didactic example used for convenience, as the whole structural model is also, without prejudice to the fact that such a model may or may not describe the truth of the actual facts. We will only be able to assure that in the (biunivocal) correspondence between a bioelectrical configuration, e.g., of the cerebellum, and the cultural structure, an equivalent figure is transferred to the latter, which preserves from the former only its “topological invariants.”

“pathways” in the complex cellular network; mechanisms that constitute the way in which the brain functions and that are similar in all human beings. Here there can be no doubt, since the possibility of understanding between men, communication, basically consists in the structural similarity of the brain that all members of the human species possess; from “communication” derives “culture as a collective fact,” which is a second degree of culture, according to the definition that we have given of it as an individual “intermediary world.”

Before the ego exists, there is already the physical body; and when the ego is extinguished, there is still the physical body. Therefore: first is the physical body and then the ego; or, more precisely: first appears the structure of the brain and then the ego.⁸⁹ It can be said, then, that, although there is a biunivocal correspondence between the two, the (biological) structure of the brain supports the cultural structure and the latter constitutes the ambit of the ego, its environment or “prison.” That is why the vast number of bioelectrical pathways that exist in the brain structure must have their correspondence with a vast number of equivalent pathways in the cultural structure, pathways from which the ego can never depart and gnoseologically condition it.

The ego is the present consciousness and, as such, maintains a constant contact with the cultural structure that surrounds it; but this contact can only be made by following the possible routes determined by the correspondence with the pathways of the brain’s cellular network. In the cultural structure the pathways take place on its “elements.” It is worth asking once and for all: what are the elements of the cultural structure? Assertions.⁹⁰ Then: “culture consists, too, of a vast number of assertions, linked together in such a way as to form a static structure.”

It is worth clarifying that “static” is the stable state of the cultural structure, which in no way signifies that such a state

89. From a metaphysical point of view, the “physical body” is the actuality of an archetypal potency that includes the ego insofar as the latter is understood as consciousness referenced to the world. But as our commentary requires dealing with facts, we invert the direction of the process in order to start from the existences given to the observation of the neighbor, of a third party, or of the community: man is, then, pure exteriority; his physical body and his conduct.

90. Earlier we said that the “elements” are preeminent cultural premises to exemplify, but, strictly speaking, these constitute logical constructions that include assertions, that is, they are paths that pass through several elements.

cannot be modified. In fact, the formation of culture throughout life supposes the constant addition of new assertions or the replacement of some by others, but in such cases we are dealing with “states of perturbation,” after which the cultural structure returns to its stable, i.e., static, state. The error of believing that there is “a living” or “dynamic culture” comes from not realizing that culture can only be interior, just as we consider it here; and of confusing, in consequence, exterior cultural objects with culture itself. It is worth repeating that external objects, even those produced by man such as a fork or a city, mean nothing outside of him; and that if humanity were to disappear, all objects used by man would cease to be cultural. That is why it is ridiculous to speak of “dead” or “living” cultures when referring to the exterior traces that human communities leave in their passage through History (or Prehistory, as intellectuals like to pompously call the epoch in which man was possessing blood purity and not writing). There is only one culture and it is structural, static, and interior; and there are exterior cultural objects, utilitarian or aesthetic, which have a significance for the man who produces and uses them and that perhaps have another meaning for future men who encounter and observe them. But the whole of all the cultural objects of a human community do not constitute its culture, they neither “live” nor “die”; they accompany it as long as it exists and alter if it evolves or they remain stable if the community stagnates or dies. By themselves the objects say nothing and that is why when an archaeologist unearths a village, of an unknown community, he must allocate part of his own cultural structure in order to *interiorly* reproduce the culture of the men who inhabited it. And this reproduction, according to the distance that it keeps with his own cultural premises, may or may not modify the structured assertions of his culture. Let us not forget that in the transcultural contact between different peoples, reciprocal modifications occur, like Greece-Rome, Spain-Mexico, etc. Thus, a quantity of buried cultural objects can never be a “dead culture” if men occupy themselves with them. And neither can they be treated as “objects of observation,” in the manner of “natural objects,” pretending to detach themselves from their human meaning; a meaning that has been restored in some way from the moment that the attention has been fixed on them. For the same reason it is not possible to objectify a historical fact by resorting to the

artifice of declaring that it belongs to the past and therefore does not include us as subjects, since the paths that the subject travels in the cultural structure in order to comprehend the fact make it a current experience that affects and conditions us. It may be that an insufficient comprehension of the historical fact changes its original meaning, its truth; it is something that will unfailingly occur, to some extent, due to the influence of the preeminent cultural premises; but the historical fact will always affect us in its character of a "cultural fact," of human making, and as such it will involve us as subjects of its plot from the very moment that we reflect on it. We will return to the double character of "historical" and "cultural" fact.

There is a confusion, then, between cultural objects and culture itself, which leads many to affirm that the latter is "dynamic." Such a confusion becomes more acute when observers pay attention to the movement that men imprint on objects or to the exchange of information that takes place between two interlocutors, which is taken as another type of movement. Against these errors we will say, for the last time, that the variations that cultural objects undergo are indeed an expression of culture, but they are the external, concrete expression produced by a human physical body guided from an internal static cultural structure. As for the "cultural exchange" the movement is the following: professor A says "the dodo is extinct"; the acoustic phrase travels through space and penetrates the sensorial sphere of student B, being neurologically transduced as a bioelectrical piece of information that affects the brain functions; the brain functions distribute this information by inaugurating a particular pathway in its cellular structure; this pathway corresponds biunivocally with another equivalent pathway in the cultural structure and a preeminent cultural premise is established, which in this case is a simple assertion. Here there has been, if the sentence was heard for the first time, a modification of the cultural structure (strictly speaking, an expansion); but once the assertion has been structured, the structure itself remains static as long as a new assertion does not appear. Thereafter, when student B again hears the phrase "the dodo is extinct," a pure function of the brain, reason, will identify, by comparison, the old pathway and a signal of recognition will alert the ego that such an assertion belongs to the cultural structure and reveal to it, to the

extent of its interest, the location and interrelationships that it keeps with other assertions.

We must now ask: what is the relationship between reason and the ego? Let us go in parts.⁹¹ In the previous chapter we defined reason as “an operator that relates different elements according to a certain ‘logic.’ The ‘operator’ is hereditary; the ‘logic,’ i.e., the agreed mode of operating, is cultural: it depends on social, ethical, moral, etc., rules and principles, and is closely linked to one’s own linguistic structure, to one’s native language.”

Let us go a little deeper into this first definition. We previously attributed a temporal primacy to the physical body over the ego: “Before the ego exists, there is already the physical body; and when the ego is extinguished, there is still the physical body.”

We must now note that the same does not occur with reason; on the contrary, reason accompanies the birth and disappearance of the ego. Because of the simultaneous appearance of both subjects, the error of identifying them with each other is common, due to the difficulty of distinguishing between them. Thus, one speaks of “rational consciousness” or “conscious reason,” improperly merging two members of different structures. We have overcome this difficulty by establishing, from the outset, the distinction between “the ego” as a present consciousness and “reason” as a functional operator, without forgetting the solidarity with in which both subjects act.

In order to grasp, in a simple way, the relationship between the ego and reason, we will continue to refer to the cultural structure model used up to this point, establishing some revealing analogies.

Let us begin by specifying the ambits of reference. By “reason” we mean a higher function of the brain, the operation of which is characterized by the bioelectrical interrelation of certain elements of its cellular structure; the concrete ambit of reason is, then, the cellular structure of the brain.

In the Paśu or lost Virya it is normal that thought is constructed with cultural elements, due to the fact that the consciousness is oriented toward the external world and all its ref-

91. For the sake of brevity we will only deal with this relationship by considering the case of logical thinking, which corresponds to modern man, and we will avoid referring to pre-logical thought, typical of the so-called primitive cultures, i.e., exercised by people purer than us.

erences come from it. The ambit of the ego (in the Paśu or lost Virya, that is, in beings who participate in the evolutive Plan of the Demiurge), is the cultural structure, which consists of a vast number of assertions. (It must be kept in mind that the cultural structure does not constitute the entire horizon of the ego; and that it is possible to separate, and even completely disconnect, the cognitive consciousness from the rational determination, just as gnosis proposes.)

Normally, then, the ego is solidarily linked to reason, each one acting in its own structure. However, a procedural order is fulfilled during the act of rational thinking: 1) from the ego to reason and 2) from reason to the ego (never the other way around). It is, of course, a mechanism that must be well known before attempting to avoid its action, but which is not difficult to explain. First of all, let us say that it is the mode that the consciousness assumes in thinking that *calls* upon reason and motivates my *response*, which always ends up determining the *form* of the thought, making any idea reasonable. This comes about because *reason responds to questioning*. But here we are not referring to a logical question; for logic is the domain of reason and intervenes a posteriori to all reflection; the questioning to which we allude is simply *a movement of the consciousness*: that movement carried out by the ego in order to know, understand, or comprehend any ideal object.

In the mental state of the Paśu or lost Virya, reason responds to almost every movement produced in the consciousness; and that is why the intelligence of any order of ideas always tends to be rational.

Seen from this point of view, the process would be the following: in front of an ideal object a cognitive movement of the ego is generated; said movement is interpreted as a formal questioning by reason, which instantly establishes a bioelectrical interconnection in the cellular structure of the brain as a solidary response; this particular interconnection, by the biunivocal relationship between structures, is transferred to the cultural structure, where it is topologically plasmated on its elements (assertions); a logical route is thus formalized that, traversed by the ego, constitutes the very intelligence of the ideal object considered.⁹² Of course, such an intelligence is

92. The topological plot enhanced over the assertions, or preeminent cultural premises, of the cultural structure is the "eminence" itself.

completely rational, given that it has been constructed according to cultural assertions, by its logical relationships, and that is why its expression, “the knowledge of the object,” will be purely conceptual.

Reason, like a shadow, follows the ego in all its movements and attempts to logically formalize its activity; analogously to the prison guards, it is an intermediary between the ego and the exterior world. But, according to conclusion 7, reason is a “dynamic intermediary,” whereas the cultural structure is a “static intermediary.” Consciousness, being oriented toward the exterior world by the mechanics of the rational cognitive process, is situated in an intermediary world that we call “culture,” where all objects of knowledge are logically constructed and are a mere rational approximation of the actual objects that they represent. (The way to free oneself from the yoke of reason does not consist in “avoiding all psychic movement” in order to elude the rational response, such as contemplative systems propose; but in taking the attention away from the exterior world and reorienting it toward a new center, from which knowledge is obtained directly from the object, by gnostic revelation. The Hyperborean Wisdom affirms that “questioning is the worst strategic error of the Virya” and recommends using, in its place, the gnostic principle: “to know is to remember”; he who questions enables reason to confuse him with its deceitful answer; on the other hand, he who disposes the Spirit to remember can come to know everything by immediate revelation given that the Truth *is already in himself*.)

The cultural structure is immersed in the psyche as part of the unconscious strata. Certain “parts” of it emerge in the consciousness; they confront the ego, as a product of rational activity. These “parts,” which notably—and inevitably—modify every idea that is the object of the questioning, or “movement,” of the ego, are rational constructions elaborated from the “elements” of the cultural structure. And these “elements” are, as we have said, assertions. But such assertions are not codified according to a grammatical language; rather, their nature is symbolic and constitutes, precisely, the origin of all language.

Making a great simplification, we can consider that symbolic assertions can be divided into two groups: an immensity of *compound* assertions and a small number of *simple* assertions or *Archetypes*. The simple assertions are archetypal symbols or

mathematical principles that intervene in the composition of many of the compound assertions.⁹³ And here is something that we were wanting to point out: during cultural learning, *simple assertions are discovered (because they are inherited), while compound assertions are rationally created or formed in reference to exterior objects.*

Thus, *in potentia*, the cultural structure is present from the very beginning of the ego's existence; for, from a few simple assertions, reason is capable of reconstructing the whole formidable plot of compound assertions. (The prison-labyrinth that holds the ego acquires gigantic proportions, which leave the prison of the allegory far behind, considering the infinite assertions in which a Culture can be formed.) However, man rarely suspects the enormous edifice on which his consciousness moves when he travels a trajectory determined by reason as a formula for knowing a thing, a trajectory that, on the other hand, is experienced as the very knowledge of a thing, a trajectory that, on the other hand, is experienced as the very knowledge of the thing or is confused with the thing itself.

Lastly, we must emphasize that the cognitive-rational process that we have described up to here prevents the complete apprehension of any natural fact or phenomenon, given that, from it, the ego will only obtain a cultural reconstruction, that is to say, a rational synthesis. In most cases the process develops unconsciously and it is not realized that the ego is dealing with synthetic images, archetypically conformed by the assertions of the cultural structure, which only bear a relative resemblance to the object of reference. But when one attempts "to investigate" a natural fact, e.g., a phenomenon, then the difficulties jump out and the rational inadequacy becomes evident. Part of these difficulties have already been considered; we now complete the concept.

Reason "knows" through a dialectical process; its means are: analysis and synthesis, that is: decomposition and reconstruction of the object under observation. For many reasons, which it would be too long to express here, among which are the sensorial insufficiency and a deficient development of the cultural structure, *reason acts with a greater precision in the decomposition than in the recomposition.* We have already criticized the

93. The principle of the fence is, using these definitions, a "simple assertion," i.e., an inherited archetypal symbol or unknown mathematical principle.

qualitative description and have qualified it as insufficient for apprehending the truth of the concrete object as a totality, i.e., its being. Let us now consider the most precise possible description of a phenomenon that can be made by rational means. Theoretically, a phenomenon can be described, completely, from the physico-mathematical point of view, establishing a system of differential equations so that each equation contains a primary variable algebraically linked to all the other variables and expresses “the behavior” in time of a primary magnitude based on all the other magnitudes.⁹⁴ But, as we said, it is easier to disintegrate than to integrate: there is no way to integrate all the differential equations that describe a phenomenon and reduce them to *a single formula* that allows access to a complete vision⁹⁵ of the phenomenon. The most that can be achieved is to arrange the equations (*in an algebraic structure!*), which is neither more nor less than the abstract of the phenomenon’s cultural structure; that is, a cultural structure (or substructure) representative of the phenomenon in which the assertions have been replaced by mathematical variables and the preeminent cultural premises by differential equations. The problem is that no one can contain in his cultural structure a mathematical structure of infinite differential equations; and such a system is needed to describe *a single phenomenon!* Not even the greatest mathematicians have achieved anything other than intuiting, in rare and fleeting ecstasies, the representation of some mathematical structures of less complexity than the one that we have considered.

This proves the impotence of any rational method as a way of knowing reality: if it is not possible to apprehend a phenomenon, even when it is transformed into an equivalent mathematical structure, how much less will it be possible to do so when one starts from a few qualities in order to reconstruct the original object! But, what is worse, the analytic method is often used for more than just investigating phe-

94. This example may be disputed, but this does not detract from its didactic merit, which is important here, since we wish to clearly show the inadequacy of the rational cognitive method, and we try to do so briefly. We do not ignore Heisenberg’s objection (uncertainty) or others like it, which nevertheless can be overcome by using discrete mathematics.

95. This is what has occurred with the mathematical expressions of gravitational and electromagnetic theories and quantum mechanics, which have resisted all attempts to integrate them into unitary formulas.

nomena: in effect, as we opportunely indicated, a historical fact is often not distinguished from a natural fact; and therefore one intends “to investigate” the historical fact, rationally, separating its parts by analysis and then synthesizing “a piacere” the past events in order to present an intentioned and often false plot of the actual fact. And this attitude is the greatest aberration, we can now understand, since the historical fact is also a cultural fact, i.e., an *essentially structured* exterior object, against which it is not possible to use the tools of the analysis of synthesis for grasping its reality.⁹⁶

Every cultural object is part of the cultural structure and, to a lesser degree, also a structure. The same does not occur with natural objects, the genesis and process of which escapes us, and about which it is often not clear whether their form is sustained by a structure or some other type of organization, or whether, perhaps, their matter has no organization at all. In such objects it is possible to apply with some success the rational method, as demonstrated by Western empirical science, and to extract knowledge. But a cultural object is essentially a structure; and as such it does not in any case allow the decomposition of its architecture.

In a structure, each element is interdependent with the other members and with the totality. That is why it is not possible, as would be the pretension of rational analysis, to consider the part separated from the whole; on the contrary, in the structure, the whole conditions the part and determines its function. A cultural object, as a structure, is a totality only apprehensible as such. But such an apprehension is perfectly possible, unlike what occurs with the physico-mathematical structure of a phenomenon, because every cultural object proceeds from the cultural structure, i.e., from the human psyche.

Every cultural object is, in this sense, a mathematical project because it has been projected, already structured, into the world from the cultural structure and, like the latter, constructed with simple and compound assertions, that is, with mathematical principles. Thus it is that cultural objects, if they

96. “Cultural objects” can be “interior” or “exterior.” The “interior cultural objects” form part of the cultural structure and constitute a first degree in the reality of the object. The “exterior cultural objects” are embodied and materialized projects of the former and represent a second degree in the reality of the object; they are recognized in the world as a reflection of the interior objects, but if this relationship is not noticed, one can commit the gnoseological error of attributing cultural qualities directly to the physical body that represents the cultural object.

are recognized as such in the world, can be apprehended structurally after their introjection; but if, on the contrary, one attempts to analytically decompose them, one will only succeed in destroying the structures and in doing so, definitively be ignorant of their functions.

Now, a historical fact is, gnoseologically, a cultural fact: the cultural fact “par excellence” (one can consider the historical fact as a “past” cultural fact). Protagonized by the members of a community, it involves in its plot not only the universe of exterior cultural objects but also the neighbor. The historical fact, in its cultural fact characteristic, is, then, essentially structural.

We already said that the analytic method is insufficient for providing certain knowledge of an external cultural object due to its structural condition and that it must be apprehended directly in the cultural structure, which is interior: it belongs to the psychic sphere. This means that, although the apprehension is carried out with reference to the cultural object itself, the cultural structure brings to the consciousness an image conformed with material independence of the object's exteriority. An object apprehended in this way is essentially structural, because it is cultural, and in no way has it been divided by reason. Does the same thing occur with a structure that is made up of a collection of exterior cultural objects, the historical fact, for example, insofar as it is a cultural fact?

First of all, let us see what kind of structure the cultural fact is by establishing, for this purpose, a relationship of analogy with the cultural structure. Let us begin by calling the structure of the cultural fact the *superstructure*, and let us consider that the “elements” that are members of it consist of exterior cultural objects. The neighbor, in it, is effectively structured as an exterior cultural object. The superstructure thus becomes purely factual and made up of cultural objects that fulfill a role equivalent to that of the assertions of the cultural structure.

But between the cultural structure and the superstructure of the cultural fact there is no opposition, but integration. In effect, there are two reasons for this: on the one hand, the superstructure surpasses the cognitive capacity of man insofar as it includes him as a member of its context, and, on the other, it possesses sufficient potency in order to capture the cultural structure of any individual and integrate it into his own exis-

tence. In other words: man, if he is an unconscious protagonist, acts as an exterior object by participating in the development of the cultural fact; but as soon as he attempts to know, and directs his attention, not to the structure of the exterior cultural objects, but to the superstructure of the fact, then the cultural structure is confronted with the superstructure and the greater potency of the latter catches the former, also “exteriorizing it” and converting it into an active subject of its drama.

It is impossible, then, to know the true form of a superstructure and not precisely because of the limitations of rational inquiry. But “the form” that supports a superstructure is the “cultural fact” itself, which, and this we once again affirm, it will not be possible to apprehend *as an object of knowledge*.

It is not possible to apprehend the cultural fact before being apprehended by it; it is not possible to take it as an object before it includes us as subjects of its drama. That is why it makes no sense to “temporally” distinguish cultural facts by the degree of potency that they possess for acting upon us and to suppose that past, i.e., historical, facts are passive and, therefore, susceptible to being taken as objects of study or “investigation.” Every historical fact is actual for the one who sets his attention on it, that is, for the one who confronts his cultural structure with the fact’s superstructure.

We have said that the superstructure of the historical fact possesses a greater potency than the cultural structure of the observer and that for this reason the former is always actual for the latter, trapping him as the subject of drama. It can be asked then: where does this tremendous power, capable of integrating man in its own process, come from? From an external organization? “From the world?” *From the psychoid collective Archetypes*. An answer that refers us to definitions “a,” “b,” and “c,” on which we will expand after considering the commentaries made up to this point.

6) Let us make a very synthetic summary of the main conclusions provided by commentary 5. First, we demonstrate the arbitrary manner in which modern Historiography uses the word “Age,” which has been emptied of its content so that it serves the sole purpose of indicating the intervals of time into which official History is divided. Then, we declare our intention to restore “Age” to its ancient meaning and, to this end, we

adopt a critical attitude toward the “rationalist mentality,” guilty of the majority of the errors that are committed when the truth of a historical fact is attempted to be known. We begin by recalling that in remote antiquity the concept of Age did not start from man but from God. But then we clarify that the ancient “Gods,” today remembered as myths, are actually exterior Archetypes (psychoid), i.e., dominant in certain epochs in order *to act on men and their environment*. Then we postulated three definitions (a, b, and c) of which, the first one was saying: “Any historical circumstance is the conjunction of humanity and certain Archetypes to which the former is subordinated by evolving toward the latter’s concretion [perfection].”

In order to understand these definitions in all their profundity, we decided to demonstrate that the “historical fact” is usually confused with the “natural fact,” to which man is alien: it is not possible, we said, to take the “historical fact” as a mere “natural fact” and make it the “object” of investigation. Why? Because the historical fact includes man in its form as a concrete support and not only prevents him from being “alien” (as with regard to the natural fact) but also manifests itself “always actual” for his attention, independently of the chronological time in which such a fact has occurred.

We said then that the key to this behavior was that the historical fact was (or had been) a “natural fact” and we defined culture as an “intermediary world between the ego and the external world.” But culture is an “interior” world, proper to the psychic sphere, and its nature is structural, so we called it “cultural structure.” We stated that the “elements” of the cultural structure were consisting of assertions and established that there was a biunivocal relationship between it and the cellular structure of the brain: the bioelectrical configurations of the cellular structure transfer to the cultural structure their topological equivalents. In order to form said bioelectrical configurations there is a function of the brain called “reason,” which “responds” to any “movement” of the ego and intercepts it as a “questioning.”

The cultural structure is immersed in the personal unconscious, except for those constructs (of assertions) that emerge toward the ego as a “rational response,” which is the crudest form of knowledge.

Finally we return to the “historical fact/cultural fact” identity, but now we see that the cultural fact is essentially struc-

tured, and so is the historical fact. But the cultural fact is factual and includes in its structure the exterior cultural objects and the men who manage to integrate its potency; it is, quite rightly, a "superstructure." That is why we were asking: where does the potency that it possesses come from? From an "exterior" superstructure, proper to the "world"? And we got the answer: from the psychoid collective Archetypes. Let us now extend this answer by resorting to the analogical comparison between the cultural structure and the superstructure.

Let us consider, for the moment, the cultural structure. Its ambit is the psychic sphere in which, as we said, it is immersed at the unconscious level. Some of its fundamental elements, the simple premises, consist of archetypal symbols with which the ideas or representations to which the ego is referenced are often conformed. Let us suppose that a certain movement of the ego, through a reflexion that is not relevant, provokes a triangular image to emerge in the consciousness as a "response." First of all we must rule out that such a triangle is the archetype itself, since by an act of will we can duplicate or even multiply the image, which demonstrates its reflexive character. The triangular archetype, like any mathematical symbol or simple assertion, always remains in the cultural structure, which it cannot leave, due to the links that it maintains with the other members of the cultural structure. The emergence (or "eminence") of the archetypal image in front of the consciousness operates from the cultural structure at the request of reason (in the structure of the brain). If the triangle archetype remains in its structure, it nevertheless possesses a sufficient potency in order to actualize an image in the conscious sphere; but this emerging image has the faculty of effectively capturing the attention of the ego.

In summary: an unconscious archetype, if it possesses a sufficient potency, is capable of actualizing itself at the conscious level and establishing a referential relationship with the ego, determining the content of the consciousness. This is true for the action of a single archetype, which is the ideal case, since combinations of simple assertions are more probable, that is, the intervention of compound assertions.

Let us suppose the case in which the rational "response" produces a movement in the image of the triangle archetype, e.g., a rotation. Here, in addition to the triangle, a "circular arc" archetype intervenes, since the combination of both will give

the image of the triangle rotating, the arc being the representation of the trajectory followed by the triangle in its movement. What does the ego do with all this? As its attention has been trapped in the emergence of the triangle, consciousness persists throughout the movement, until the extinction of the image. An important conclusion must be drawn from this: from the emergence of the archetypal image until its extinction, it underwent a series of referential modifications, for the ego, which constitute a *process*. Well, let us express these considerations in a general way: “the emergence of archetypal images in the consciousness tends to enrapture the attention of the ego throughout its process.”

This process can only be interrupted by an act of will that enables the ego to subtract itself from its reference to the emerging images. But the will is simply a quantity of energy available to the consciousness for its utilization; if this energy is sufficient, then the attention will be taken off the image; but if it is *insufficient*, the image will continue to enrapture the attention of the ego and will remain evolving at the conscious level. When the ego is thus linked to an archetypal image, this signifies that it has been momentarily incorporated into the cultural structure, of which it will form part during the process, since the energy necessary for such a process to continue is contributed by the consciousness itself, albeit involuntarily.

We will explain it step by step. Archetypes possess an energy of their own that allows them to maintain themselves in the cultural structure, but which is insufficient to make their emergence at the conscious level possible; for this to be possible, additional energy is needed. Where does the energy with which the archetype increases its potency and crosses the threshold of consciousness come from? From the flexions of the ego. A flexion of the ego in a certain direction can vitalize an archetype sufficiently for it to actualize its image, which will tend to unfold by attempting to concretize itself and will take, for this purpose, more energy from the consciousness.⁹⁷ A very powerful archetype can manage to empty the consciousness of all content and force it to carry out its process, so that

97. We speak of “image” because we continue to refer to the example of the triangle-Archetype, which is purely formal; but it could also be another type, e.g., a pattern of conduct or “instinct,” which would induce the ego to adopt a certain attitude.

the ego becomes an expression of the archetype itself. This absorption of the consciousness by the unconscious archetypes and the consequent subjection of the ego to a process of unfoldment does not necessarily imply the loss of the individual sense, but the almost absolute weakening of the will, impotent to wrest the ego from its formal limits.

Summarizing: the emergence of an archetypal image (or any other manifestation with which the archetype actualizes its presence) will be objective⁹⁸ and, as such, susceptible to knowledge, to the extent that the ego preserves its volitional energy; but if the ego is attracted to the image, whether it merges or identifies with it, and participates in its process, then there is no longer any subject/object differentiation and the ego becomes integrated as an *active subject* of an unfoldment originated in the cultural structure and, therefore, essentially structured. Enchained to the process, to a process that is fed by its own energy, the ego can only wait for the concretion of the unfoldment, for the entelechy of the archetype. Finally, it is worth repeating that the archetypes, being elements of the cultural structure, basic matrices of the mind, will always be unconscious and irrepresentable and can only be known through their manifestations.

Before explaining the analogies that certain aspects of the cultural structure and the superstructure present, it is necessary to make two clarifications.

The first is that, as has already been explained at length, we deny any value to external cultural objects as “expressions of a culture”; and instead we value the “cultural fact” in which, together with cultural objects, the human presence participates. We know that the “cultural fact” is structured; it is factually sustained by a superstructure that includes objects and men. It is, then, the perception of the superstructure of the cultural fact (a purely exterior reality) that is vulgarly called “culture.” Against this gnoseological error we declare that “Culture is an intermediary world between the ego and the exterior world.” Culture, thus understood, consists of a static “cultural structure” of a psychic nature and a dynamic operator, “reason,” a function of the cellular structure of the brain.

The second clarification refers to the term “*psychoïd*” that Dr. C. G. Jung has used for designating the absolutely tran-

98. In this case, “objective” means “object-like,” rather than “real” or empirical.

scendent character to the consciousness of the collective Archetypes; their unrepresentability. Here we give to said word a restricted meaning, which is worth defining in order to avoid confusion: “psychoid” are the Archetypes of the superstructures, which are “external,” different from the “internal” cultural structures, the Archetypes of which are of a “psychic” nature.

We must now speak about the psychoid collective Archetypes. First of all, let us say that to the same extent that the archetypes of the cultural structure are “irrepresentable,” the “psychoid” Archetypes are “inapprehensible” by the cultural structure and “irreducible” by reason. It is impossible, then, to “take cognizance” of a psychoid Archetype through the “cultural way.”

The psychoid Archetypes are the product of the Will and Imagination of the Demiurge; but here it is necessary to take into account some concepts of the Hyperborean Wisdom.

- 1) Although there are countless psychoid Archetypes, they are all made up of combinations of a single element: the archetypal monad.
- 2) The monads are the “first” emanations of the Demiurge.
- 3) They possess sufficient potency for actualizing themselves on the physical plane, or rather, the “physical plane” or “three-dimensional space” is the “actual” expression of the monads. A UEVAC “archetypal quantum of energy” corresponds to a monad on the physical plane.
- 4) The first manifestation of the Demiurge is the emanation of the monads; the second is the Verb or Logos, which “orders” the monads into psychoid Archetypes.
- 5) The psychoid Archetypes are manifested on the physical plane in a “formal” manner due to the fact that the monads with which they were “ordered,” i.e., conformed by the Logos, are also manifested, pointwise, with UEVAC energy units. On the physical plane, the set of UEVAC units corresponding to the monads of the psychoid Archetype formally “describes” the Archetype. But even if said physical form contains the most diverse varieties of substance, the transcendent support of its material structure is always constituted by the psychoid Archetype.
- 6) The psychoid Archetypes that interest us most, those that actualize themselves in the terrestrial forms, have their seat

in the “psychosphere”: “a great field that surrounds the Earth and totally interpenetrates it,” as defined in the Fourth Dissertation.

Although all physical bodies or natural objects, and, in general “every form,” are sustained by psychoid Archetypes, hereafter we will reserve this denomination for those “forms” that are the object of this commentary: the “cultural facts.” And here we are not dealing with a whim, since the cultural fact is also, for the Demiurge, the most important object of all His “creation.” But this statement deserves to be clarified.

We already said that the Hyperborean Spirit was enchained to matter by a Mystery of A-mor, and that the Traitorous Siddhas contributed to this. We will now expose a fundamental concept of the Hyperborean Wisdom that explains the reason why the Demiurge *is interested in* enchaining the spirits. This reason has nothing to do with “Good and Evil” or any other dualistic justification: let us remember that at the “coming” of the Hyperborean Spirits to the Solar System, the latter had already been constructed by the devic Hierarchy following the “direction” of the Logos and, therefore, all the pairs of opposites were already manifested.

The concept is the following: the Demiurge *needs* the Hyperborean Spirits enchained in order to form the cultural superstructures, *given that without them the cultural facts would not take place.*

Surprising, is it not? It is worth commenting on.

The Demiurge “thought” of man as the culmination of His creation, just as His Hebrew worshippers recount in Genesis. Naturally, “man” created by Jehovah Satan was an Archetype that was requiring, for its physical concretion, an evolution of life and form. After certain periods of time the unfolding of the “human monad” should be completed and “man,” faithful to his Archetype, should be converted into the king of creation. But this absurd Plan failed and, after millions of years of waiting, the Demiurge had become convinced that His “hominids” were not acquiring a single spark of individual consciousness. And without this consciousness, the unfolding of the collective archetypes that He had so carefully prepared for the “Paśu communities” to progress into cultural forms would not be feasible.

The failure was so resounding that, when the Hyperborean Spirits entered the Solar System, they found that the Paśu of

the Earth, after hundreds of millions of years of “evolution,” had never managed to emerge from animal savagery. The “solution” was offered to the Demiurge by the Traitorous Siddhas: a genetic alteration of the human species and the incorporation of Hyperborean ancestors into their heritage would make the Paśu “true men,” producers of “culture...” All the civilizations of Earth are subsequent to that infamous treason, known as the Mystery of A-mor...

Since then the Paśu and the lost Virya produce “cultural facts,” superstructured by psychoid Archetypes, which also comes to explain definition “a”: “Any historical circumstance is the conjunction of humanity and certain Archetypes to which the former is subordinated by evolving toward the latter’s perfection.”

We will now complete the promised analogies.

Let us recall the following conclusion: “the emergence of archetypal images in the consciousness tends to enrapture the attention of the ego throughout its process.” In the “exterior world” the emergence of a psychoid Archetype is called a “cultural fact.” The cultural fact is the form that contains a superstructure of cultural objects, as has already been defined.

The Archetype of the psychic sphere (simple assertion) possesses an energy of its own; but, in order to emerge, it needs additional energy, which is contributed by the flexions of the ego. The psychoid Archetype of the psychosphere also possesses an energy of its own; but, in order to emerge, it needs additional energy, which is contributed *from the universal collective unconscious*. (The “universal collective unconscious,” in which the “personal collective unconscious” participates, is a concept that will be correctly defined in the Fourth Dissertation, where a technique of Psychosocial Strategy based on the properties of the psychoid collective Archetypes is studied. For now, the following is valid: the universal collective unconscious is part of the psychosphere.)

When a psychoid Archetype is actualized in a superstructure, the latter does not remain still but, on the contrary, shows itself animated by a determinate movement. The form, that is, the cultural fact, evolves toward its maximum perfection, which is also the closest possible approach to the “archetypal form”; that is why we call the “final form” “entelechy,” which is the Archetype itself, toward where the evolution of the fact tends. But the form is sustained by the superstructure, so that

it is in it, in each one of its elements: cultural objects and human community, which develops and concretizes the psychoid Archetype.

In this evolution the Archetype brings into play an enormous amount of energy, which constitutes the very “reserve” of the community (energy taken from the “collective soul”) and which is transformed and channeled into the superstructure.

It is now understood why we were affirming that the “greater potency” of the superstructure was capable of capturing the cultural structure of an observer and integrating him into its own existence. The greater potency comes from the fact that the energy that impulses the development of the cultural fact is of a degree superior to the human, i.e., to that of the individual man, since its origin is collective. The cultural fact evolves toward its entelechy, but progressing instant by instant in different concrete realities. If a man “does not participate” in the cultural fact, an impossible hypothesis as we shall see, if he confronts its reality by taking it as an object of knowledge, he will attempt to rationally reduce the concrete reality by abstracting certain eminent qualities. We already explained that it is not possible to apprehend a superstructure, nor any structure, using the analytical-rational method, going from the concrete to the abstract. But the problem here is not that man, the objective “observer” of the superstructure, obtains an erroneous concept of it; but that by this very act of observing he becomes one more element of the superstructure, through which the evolutive impulse of the psychoid Archetype is channeled.

The cultural fact is being developed by a great potency, *whether the observer notes it or not*; and in this march toward entelechy the superstructure *takes what is necessary for its perfection and rejects that which is useless or opposed to it*. Except in the case of the awakened Virya, who will be rejected because of his opposition, all men *are necessary* for the evolution of the fact insofar as they participate in it. But to be an “observer” is to already participate, as a witness; and that is why all the potency of the superstructure will be concentrated in order to achieve his integration. This is not difficult because when “observing” (the cultural fact) the “cultural structure” of the observer and the superstructure are confronted, producing what the Psychosocial Strategy calls “*capture*,” i.e., the integration of the cultural fact into the evolutive process.

Naturally, in a cultural fact one or several men participate unconsciously, who are ultimately the ones from whom the psychoid Archetype feeds in order to develop; we have not wanted to touch on this aspect of the superstructure because it is studied in the Psychosocial Strategy within the theory of “gregarious phenomena” (Fourth Dissertation) and because the case of the “observer” captured by the superstructure is highly didactic for clarifying what we have been exposing about the fallacy of considering “cultures” as an “object of knowledge.”

How is capture produced then? Because when the “reason” of the observer explores the superstructure, he discovers in it his own projections; i.e., he “sees” in the exterior world things of his interior (unconscious) world. But these projections do not occur accidentally, but are sought by the psychoid Archetype by adequately disposing the superstructure to receive the convenient images. If the observer believes to see that the cultural fact develops according to his own interior processes, he will voluntarily integrate himself to the exterior process or, what is the same thing, he will weaken his will of opposition. We will ask ourselves: how is it possible for the observer to see that which suits the evolution of the psychoid Archetype and not something else? And we will try to explain it by means of a metaphorical figure. Let us imagine a mosaic in which the images of all the persons we have known in our life are arranged, one next to the other, in no order. It would undoubtedly be a enormous painting, let us suppose about a thousand square meters. Let us imagine, again, that such an enormous mosaic is standing vertically behind us and that we cannot turn around to see it. We have only the resource of using a small mirror, which will reflect back to us a portion of the mosaic, because it is too big and we are too close to it. Well, things being thus arranged, it will be enough for us *to modify the position of the mirror* in order to obtain the reflection of each one of the mosaic’s faces. But among the many persons represented there, there are some that we love, others that we hate, others that hate or love us, those that arouse pity or resentment, etc.; i.e., the persons that we have known in our life are not only memories, but, associated with their image, there is an affective charge that is made evident by the evocation. That is why when we move the mirror we see a face that makes us smile and then another one that we do not want to remember, and a

third one for which we shed a tear, and then, perhaps, we return to the one that made us happy and we stop for a long time on it, or, if we have not found it yet, we will move the mirror and we will go through the mosaic *seeking* the most beloved face.

Within us there are always things that we want to see, feel, or do and others that we try to deny or hide. In order to trap ourselves, we only need to confront the reflection of our own desires. The psychoid Archetypes “orient” the superstructures (as if they were the mirror of the metaphor) so that they reflect that which we unconsciously wish to see (the process of our own interior Archetypes) in front of which (as in front of the faces that make us smile and love) we will remain attracted for a long time.

The metaphor has shown us in what way the capture *begins*: a reality *oriented* to reflect the interior expectations and affective projections of the observer; subsequently: the attraction of the exterior illusions that we believe to discover realized in the cultural fact. This is, however we look at it, an authentic violation of the psychic intimacy of the observer and of its subsequent submission to the evolutive process of the superstructure, i.e., to the Great Deception, to Maya: “the illusion.” That is why we said, pages ago, that “the greatest potency” of the superstructure was capturing the cultural structure and integrating it into its process by *exteriorizing it*.

Once man has been incorporated into the exterior process, the psychoid Archetype will feed on his own energy and determine his behavior within the formal limits of the cultural fact.

What possibilities does the man have to avoid capture? Very few. In the state of the lost Virya it is very unlikely that he will succeed in escaping the archetypal processes of which the exterior world reality is made up. That is why the Siddhas try to awaken the Minne, the gnostic consciousness, inducing the Song of A-mor; and procure, by different strategic means, to destroy the superstructures that include the Hyperborean lineages in their evolutive processes. For the Hyperborean Gnostic the process of the psychoid Archetypes has a specific name: *drama*; and its final perfection, its entelechy, is perceived as a *catastrophe*. The lost Viryas who participate in a cultural fact do so as actors in a drama of which storyline is unknown and transcendent. Let us note one more definition: a “dramatic sto-

ryline” is the content of the psychoid Archetypes, the concrete manifestation of which is the superstructure of cultural facts.

In effect: the Archetype develops in the superstructure and its potency aims at the entelechy of the cultural fact, i.e., at the catastrophe; in this process it “takes what is necessary in order to reach its perfection,” incorporating into the drama anyone who is in a “*cultural relationship*” with the superstructure, i.e., anyone who “knows” the cultural objects of the superstructure by identification with assertions of his own cultural structure. This concept makes it possible to define a “radius of action” or sphere of influence of the psychoid Archetype from the two basic elements of which the superstructure of the cultural fact is made up: the “cultural objects” and the “man” (lost Virya). Wherever a “cultural object” is recognized, it will always be a plane of action for the psychoid Archetype, which will incorporate the observer as an actor in its drama; conforming a “superstructure” and forming a “cultural fact.”

We see, then, that for the process of a psychoid Archetype there is no need for time: only cultural objects and culturizing subjects are required, i.e., men provided with a “cultural structure” for whom the mentioned objects are identifiable. Hence, past facts can return to be repeated, becoming “actual,” from the very moment at which a “cultural relationship” is established with an observer, i.e., with someone who suffers from the illusion that a cultural fact can be the object of his observation. A historical fact, that is, a past cultural fact, will always be potent for incorporating a man as the subject of a drama. This being so, where does the potency necessary for this come from?

We have said that in a superstructure, capable of “capturing” a man and incorporating him into its process, the potency comes from the psychoid Archetype toward which entelechy the latter evolves. But a superstructure is factual, concrete at each moment of its unfoldment; the potency that gives actuality to the cultural fact is clearly noticed in the dramatic change that is manifested in the fellow man, the unconscious actor (like ourselves) of a transcendent and inapprehensible storyline. It is acceptable that this prodigious potency, which develops in an irresistible way as a “force of destiny” or “direction of the drama of life,” comes from a “dominant” psychoid Archetype in the present moment, since “we can verify it in the dynamics of the cultural fact,” of “this” cultural fact in which we

are included as active subjects. But, from a past fact, it is not noticed with much evidence how there can be a sufficient potency in a “devalued” psychoid Archetype, transformed into a “myth,” in order to capture an observer and incorporate him into its drama. However, it is an illusion produced by the excessive dependence on the temporality of the exterior world, by the synchronization of the biological clocks of the microcosm with the time of the macrocosm, which translates into an artificial exaltation of the “present” as the temporal support of the consciousness: hence the lost ego is always “present consciousness.” In reality a psychoid Archetype that was dominant in the past, and of which process gave rise to a historical fact, has not vanished into nothingness, just because it has *once* reached entelechy in History: to think that would be like assuming that that corn plant, the germination and growth of which we have observed, will not be able to return to be repeated after its evolutive process has been exhausted. But we know that this is not so and that, in nature, life repeats itself following the cycle of the formative process. In this sense the psychoid Archetypes of a superstructure do not differ from those that sustain the natural forms and both *cyclically* attempt to manifest their process and evolve toward the concretion of their entelechy.

A psychoid Archetype never dies. If it “disappears” from sight (i.e., from the collective consciousness) this can be due to two causes: either it continues to act effectively but at an unconscious level, or it has really lost its effectiveness to act; the latter means that it will remain in the psychosphere until the time in which a human community vitalizes it and incorporates itself into its process. But a “sleeping” psychoid Archetype, a myth, is a germ that procures to develop at all times; and that is why it is not possible to contemplate the historical fact, to “study it and know it” objectively, for it immediately incorporates us as subjects of its drama. Of course, this capture does not mean that the historical event will be repeated just as it was at the moment in which it occurred; for that to happen, it would be necessary for nothing to have changed, e.g., for all the cultural objects and the same climax of the event that we are evoking to be there. This is not how a psychoid Archetype manifests itself. *Just as* no kernel of corn is the same as any other, but does not, for that reason, cease to be corn, the forms that the facts produced by the same Archetype acquire, in dif-

ferent historical epochs, allow a certain degree of variation, neither essential nor structural. The cognitive relationship established with the psychoid Archetype of a historical fact, even if it is not enough for it to develop completely, *is sufficient*, nevertheless, for it *to develop to some extent*. And that development, that potency that begins to flow in us upon “grasping” the dramatic plot of the historical fact, implies the capture and inclusion into a superstructure, in the same way as if we had observed an apparently “more current” or “present” cultural fact.

7) We may now return to definitions “a,” “b,” and “c.” Applying the concepts seen so far, it is better understood what we meant by: (“a”): “any historical circumstance is the conjunction of humanity and certain Archetypes (or myths) to which the former is subordinated by evolving toward the latter’s perfection.” We could also add: “The historical fact is the concrete form that a superstructure of men and cultural objects acquires during its evolution toward the entelechy of the psychoid Archetype.” A Historical Age is thus, not a simple period of time between eminent facts, as official History would have it, but “the evolutive process of the Manu Archetype.” This psychoid Archetype, which acts upon the whole of humanity, takes thousands of years to develop and is the true “force of History,” the ultimate dynamic of every cultural fact. Under its enormous mantle are sheltered other lesser orders of collective archetypes. Such archetypes may manifest themselves in various facts, but *all facts* keep among themselves a structural relationship called *macrostructure, age, or yuga*; the macrostructure (of all cultural facts) is a concrete form of the Manu Archetype.

So powerful is this Archetype that the beginning and end of its process is accompanied by tremendous modifications in the terrestrial surface and by an “evolutive leap” in the humanities that populate it. This means that there is a telluric influence of the psychoid Archetypes in relation to human evolution. In the following paragraphs this relationship will be explained; since without the concept of “microclimate” and “psychoid island” it will not be possible to grasp the *geochronic* effect that the Earth exerts on the different ethnic groups and the reason for the ancient strategic migrations. When we set forth the story of Nimrod, The Defeated, we made a brief allusion to the

fact that the Demons of Chang Shambhala were fulfilling “absurd Manu roles.” This statement refers exclusively to the method used by the Traitorous Siddhas in order to genetically “adjust” the different races: for this purpose, they precipitate the entelechy of a human Archetype and, momentarily incarnating themselves in that body type, give themselves over to copulating with members of the race that they intend to “evolve,” a task for which they have always demonstrated a special predilection.

We cannot develop a schema of the planetary and solar Hierarchy here because of the length of the text that this would demand from us, and because our objective is to expound the Hyperborean Wisdom, i.e., the gnostic science that teaches to the captive Spirit the way to liberate itself from material chains, and not to waste time in commenting on the infamous work of the Demiurge. But it is worth remembering that the Earth forms part of an “evolutionary chain” as do the other planets of the solar system, all being included in a Plan of Evolution (Colossal Archetype) conceived by the Solar Demiurge or Solar Logos. However, in these dissertations, when referring to the Demiurge we generally do so by thinking of the Planetary Logos or Sanat Kumara. The Manus depend on Him: the “seed Manu” is the “idea” of the Earth with its seven kingdoms, which He evolutionarily impels in its development. Then there is the root Manu, which is the Archetype of a humanity, including its races and sub-races. There are also Manu Archetypes of a “root race,” etc.

As we have already said many times, the Demons of the Hierarchy claim that “evolution,” according to the Plan, produces an undeniable progress in the “incarnated egos.” The fulfillment of the archetypal patterns is a true entelechy and, that is why, every man who has passed a certain number of incarnations, subject to Karmic laws, must transcend to the human level and pass to that of the “superhuman” or adept level, i.e., to become a part of the Hierarchy. Just as we expressed it pages ago, referring to the synarchic conspiracy that aims at valuing the future and obscuring the past, we now verify the metaphysical origin of that attitude: in the future are the entelechies of all the Archetypes and, consequently, human perfection “by evolution” toward a Manu Archetype.

However, since ancient times, this idea was opposed by the concept that, as the Ages were passing, man was devolving and

falling more and more into the mire of matter. For those who held this opinion, life was constituting a “drama” and the future, a “catastrophe.”

It is easy to notice that this concept comes from the Hyperborean Wisdom and that it is not simply an “idea contrary” to the Plan of Evolution, but the product of perceiving gnostically, with the blood, the tragedy of the Spirits enchained to the evolution of the psychoid Archetypes. Such a perception corresponds to an intuition of the divine origin of the Spirit and to the certainty that every subsequent time represents a decadence: the loss of a state of primordial divinity.

This concept of spiritual “fall” and “loss” of divinity is clearly Hyperborean and very ancient. But, over the millennia, this concept became exoteric and gave rise to various mythological figures in which the ancient perception of the primordial Origin is nevertheless clearly recognized. The first of these figures is that of the “Golden Age,” where the “immortal Spirit” has been humanized and imagined as inhabiting a Paradise or Eden. But even so, as exoteric as this image is, it is an ancient Hyperborean concept and should be recognized as such. Later degradations conceived of four “Ages,” each more decadent than the last, as can be read in the major Greek classics (Homer, Hesiod, etc.). The Roman poet Ovid, who lived in a late period (43 BC–17 AD), gleaned from the Greek tradition the following:

THE FOUR AGES

“The *Golden Age* was first, a time that cherished of its own will justice and right; no law. No punishment, was called for; fearfulness was quite unknown, and the bronze tablets held no legal threatening; no suppliant throng studied a judge’s face; there were no judges, there did not need to be. Trees had not yet been cut and hollowed, to visit other shores. Men were content at home, and had no towns with moats and walls around them; and no trumpets blared out alarums; things like swords and helmets had not been heard of. No one needed soldiers. People were unaggressive, and unanxious; the years went by in peace. And Earth, untroubled, unharried by hoe or plowshare, brought forth all that men had need for, and those men were happy, gathering berries from the mountain sides, cherries, or blackcaps, and the edible acorns. Spring was forever, with a west wind blowing softly across the flowers no

man had planted, and Earth, unplowed, brought forth rich grain; the field, unfallowed, whitened with wheat, and there were rivers of milk, and rivers of honey, and golden nectar dripped from the dark-green oak-trees.

“After Saturn was driven to the shadowy land of death, and the world was under Jove, the *Age of Silver* came in, lower than gold, better than bronze. Jove made the springtime shorter, added winter, summer, and autumn, the seasons as we know them. That was the first time when the burnt air glowed white-hot, or icicles hung down in winter. And men built houses for themselves; the caverns, the woodland thickets, and the bark-bound shelters no longer served; and the seeds of grain were planted in the long furrows, and the oxen struggled groaning and laboring under the heavy yoke.

“Then came the *Age of Bronze*, and dispositions took on aggressive instincts, quick to arm, yet not entirely evil.

“And last of all the *Iron Age* succeeded, whose base vein let loose all evil: modesty and truth and righteousness fled Earth, and in their place came trickery and slyness, plotting, swindling, violence and the damned desire of having. Men spread their sails to winds unknown to sailors, the pines came down their mountain-sides, to revel and leap in the deep waters, and the ground, free, once, to everyone, like air and sunshine, was stepped off by surveyors. The rich Earth, good giver of all the bounty of the harvest, was asked for more; they dug into her vitals, pried out the wealth a kinder lord had hidden in Stygian shadow, all that precious metal, the root of evil. They found the guilt of iron, and gold, more guilty still. And War came forth that uses both to fight with; bloody hands brandished the clashing weapons. Men lived on plunder. Guest was not safe from host, nor brother from brother. A man would kill his wife, a wife her husband. Stepmothers, dire and dreadful, stirred their brews with poisonous aconite, and sons would hustle fathers to death, and piety lay vanquished. And the maiden justice, last of all immortals, fled from the bloody Earth.”

In this account of Ovid, and in others like it, there has been a desire to see the memory of human prehistory and the confirmation of the glaciations, which is not entirely inaccurate. But, under the mantle of myths and legends, the aforementioned concept is clearly noticed: at first a Golden Age, which

is a degraded idea of the “Origin,” and then three “Ages,” of Silver, Bronze, and Iron, in which man accentuates his spiritual decadence more and more. And this concept, underlying the shell of the myth, is clearly Hyperborean, just as we said.

In India, so culturally seduced by Chang Shambhala’s “Masters of Wisdom,” a solution to humanity’s evident fall into materialism has been given by the incorporation of the four Ages in their eternal cycles of return. The “Ages” are *Satya Yuga* (Golden Age), *Treta Yuga* (Silver), *Dvapara Yuga* (Bronze), and *Kaly Yuga* (Iron); of course, these four “Yugas” or “Ages” form a *Chatur Yuga*, which returns to repeat itself eternally in the various manvantaras, or the Demiurge’s periods of manifestation. The “fall” is justified here in order to facilitate new “Karmic ascents” within the sinister Plan of Evolution, which has its concrete expression in the Manus or psychoid Archetypes. But this is only a cultural maneuver of the Masters of Chang Shambhala, those who have sown confusion in the Hyperborean traditions of the ancient Aryans: the “fall” is true and there is no person who has survived the “nights” that follow the “Days of Manifestation,” be they Yugas or manvantaras, when the Demiurge, like a horrifying monster, reabsorbs the famous “material creation” into his substance.

Of particular importance to us will be the concept of Kaly Yuga, the esoteric equivalent of the Aegean Iron Age, which we are going to expound according to the Hyperborean Wisdom. But first we will say two words about the “Golden Age.”

As we said, the “Golden Age” is an exoteric figure, founded on the perception of the Hyperborean Origin of the Spirit. But perhaps it is worth clarifying why in different civilizations the image of the “Earthly Paradise,” which is an immanent idea, always appears linked to said imitation of the “Origin,” which is a transcendent idea. For example, in the Epic of Gilgamesh a paradise inhabited by Enkidu is described; and the same is the “Garden of the Hesperides” or the “Elysian Fields” in the Greek myths; not to mention the Bible or Airyanem Vaejah, the paradise of the Parsis, etc. Here the following Hyperborean criterion must be adopted:

1. The “fall” of primordial man, and all myths that allude to it, refer in a distorted way to the enchainment of the immortal Spirit to matter; its captivity and enslavement to the work of the Demiurge. There is, then, a veiled reference to the “Origin.”

2. The “Earthly Paradise” *is a memory of the Paśu*. In effect: when the Siddhas enter the Solar System, they find on Earth a hominid, an ancestor of the Paśu, which was all that the Demiurge and His Devas had been able to achieve after millions of years of the Manu’s “evolutive unfolding.” But this wretched creature, which was perhaps why it was not evolving, was in a true “paradise,” enjoying itself happily and under the care of the Devas. After the Treason of the Siddhas, because of the Mystery of A-mor, the Paśu began to “evolve” more quickly due to the contribution of the Hyperborean lineage and the captivity of the Spirits coming from Venus. However, the memory of that era of complete happiness and total idiocy was preserved in their genetic memories. As we were affirming before, “the Hyperborean Spirit is necessary for the Demiurge’s Plans because it is a maker of culture”: it is enough to observe the qualitative and formal richness of the Golden Age’s myths in order to verify it. In such cultural hybrids the primitive, animal images of the Paśu have been transformed until adopting a “mythical,” i.e., archetypal, form, thanks to their “adaptation” to the superior patterns of the Hyperborean Race. Only in this way can there be an “evolution”: when a cultural structure is capable of containing assertions (symbols) that make possible the process of the psychoid Archetypes. In the “myths” of the Golden Age, better than in any other, this double content, which is the basis of “culture” (and the proof of the Siddhas of the Dark Side’s Treason), can be verified: a genetic memory of the Paśu (the “Earthly Paradise”) and a Blood Memory of the Hyperborean Spirit (the “Divine Origin”); their “combination” yields the various myths of the Golden Age.

8) We have set forth in definition “c” what is to be understood by an Age, and then we explained said definition, which is worth recalling now: “A historical Age is the conjunction of humanity, during such a period, and of a Manu Archetype, to which the former is subordinated by evolving toward the latter’s perfection.” We also know that an Age is a macrostructure and that this is the concrete manifestation of the Manu’s evolutive process; that is why, in the Age, progress is made toward a perfection, the ultimate concretion of which is the entelechy of the Manu: the realization of the Plan. But this perfection is, for

the enchained Spirit, a catastrophe, as the Hyperborean concept of Age (Aegean, Sumerian, Indo-Aryan, etc.) affirms, as we have seen in Ovid's example. We are now interested in referring to the present "Age," of "Iron" or of "Kaly."

In the present Age, humanity "progresses" by tending toward the entelechy of the Manu (Vaivasvata). It should thus be called "Vaivasvata Yuga." Why the name Kaly Yuga? First of all let us remember that such a name comes from the Hyperborean Wisdom and, therefore, must have a special signification for awakened Viryas; a kind of "message" that expresses some esoteric type of "orientation." In effect: behind the suggestive name of Kaly, chosen for designating our epoch, is concealed a Greater Mystery, which is known as the Mystery of A-mor. We made mention of it in the allegory of the prisoner, and now we will attempt to approach an aspect that touches us Westerners of the twentieth century very closely. But we must clarify that this Mystery is immense, as great as the drama that each one of us has to live in human existence; and that is why we can only aspire to give some indications, to highlight signals, that orient those who seek to liberate themselves from the evolutive chains in the direction of the truth. However, to achieve this end, we will have to depart, as we did on other occasions, from the orthodox concepts that constitute dogmas today, and go back to very ancient meanings taught by the Hyperborean Wisdom. We will begin then by defining Kaly.

For the Hyperborean Wisdom, the incorporation of Shiva, together with Vishnu, to the Demiurge Brahma is equivalent to the union of Christ with the Demiurge Jehovah Satan and the Holy Spirit. Both trinities are exoteric, proper of religious cults and, therefore, historically tardy. Before the conformation of the myth, the Gods acted separately and we have already explained how the Demiurge imitated, with Jesus Christ, the Atlantean historical figure of Khristos Lúcifer. Shiva, like Christ or Apollo, has been, from the beginning, the image of Lúcifer, the Great Chief of the Hyperborean Siddhas; and only the imitative passion of the Demiurge and the imagination of the Priests, could conceive a trinitarian association. There is a great irony in all this; for Lucifer represents absolute individuality, that is to say, absolute freedom; and He could hardly be associated with the Lord of Slavery, He who prevents all freedom. In order to refer to the Mystery to which the name "Kaly Yuga" alludes, we must therefore go back to its Hyper-

borean meaning, which bears little relation to the religious concepts of Buddhism and the different Hindu schools of yoga.

These clarifications apply especially to the black Kaly, the “wife” of Shiva, who is exoterically considered as a “negative aspect” of Parvati, His “white” wife. By the religious, i.e., mythical, way, syncretism goes so far that Parvati is in turn Shakti, the “creative energy” of the Living Universe. Here, as with Shiva, we will refer to the Hyperborean Wisdom, which teaches that Kaly, as well as the Egyptian Isis, the Babylonian Ishtar, the Roman Venus, the Greek Aphrodite, the Chinese Hsi Wang-mu, the Gnostic Sophia, etc., are all images springing forth from the Blood Memory of the Hyperborean lineages. Blood Memory, we say, but of whom? Of LúCIFER’s “wife,” whom we may henceforth call Lillith. But this, as everything that we have been saying, requires some complementary clarifications. For this purpose, we will expound certain concepts of the Hyperborean Wisdom; but let us always remember that we are looking at things *from the Origin* and that, although the Names have reached our times, the conceptual content that we grant to them here is very ancient and esoteric.

First: The “Hyperboreans” are members of a Cosmic Race in which there is a sexual differentiation. This affirmation only signifies that its members are male and female *in this universe*; we can know nothing about what occurs outside of it.

Second: Sex, among the Hyperboreans, does not fulfill the function of procreation. The Race has not diminished since it has been in material captivity because *it is immortal*; but neither has it grown.

Third: The sex of the Hyperboreans has nothing to do with the differentiation into pairs of opposites that characterizes the creation of the Demiurge. The coming, and the subsequent captivity, of the Hyperborean Spirits, is much more recent than the origin of the Solar System’s creation; not to speak of the colossal antiquity of the Universe of The One. When they penetrated through the “Gate of Venus,” creation was already consummated, the opposites separated, and man or the hominid was inhabiting the Earth. It is not correct, then, to attribute a *primordial androgyny* to the Hyperboreans. It is the Paśu who passed through an androgynous evolutive stage.

This process, which can also be recognized in human physiology by observing the endocrine glandular bisexuality, is en-

graved in the genetic memory; and that is why in cultural compositions the two mnemonic ascendants are intermingled: the genetics of the Paśu and the minneics of the Hyperborean. We already explained that culture arises from similar combinations and it will not be difficult now to understand why the religious images of Shiva and Kaly appear confused.

Hyperborean Spirits are absolutely differentiated by sex. It has always been so since they arrived in the physical universe, and there is no record that proves otherwise. The Paśu, on the other hand, has passed through an evolutive stage in which its body was androgynous, long before arriving at a "biological" differentiation of sex. But the soul of the Paśu has no sex. It can incarnate indistinctly in male or female bodies.

Fourth: There are, then, male and female Hyperborean Spirits. However, we always refer especially to the figure of the awakened Virya as a "hero" or "warrior." Are there not perhaps Hyperborean women, i.e. female captive Spirits incarnated in the physical bodies of Paśu women? In order to respond we must touch upon one of the most occult aspects of the Mystery of A-mor: the Hyperborean Wisdom affirms that the primordial fall was overwhelmingly more protagonized by male Spirits than by female ones, the former being enchained thereafter to the evolution of the Paśu. That being so, what became of the missing female Spirits, those who were not deceived by the Traitorous Siddhas and who never incarnated? They await the return of the Viryas to their origin in Valhalla: they are the Valkyries of Nordic mythology. But it is more important for us to know the role that *Kaly-women* play in the drama of human life. We will soon find out.

These four concepts will enable us to approach that aspect of the Mystery of A-mor that "touches us Westerners of the twentieth century very closely," as we said before: it is that which refers to tantric practices.

Tantra Yoga



ere we will not summarize tantric philosophy and yoga; for acquiring this knowledge there are excellent books that we recommend reading.⁹⁹ Instead, we will refer to some esoteric symbols that every tantrika should know and we will show why the practice of sexual yoga often “fails” among Westerners, i.e., it often has disastrous effects on the physical and mental health of the sadhaka. We will thus take a large part of this philosophy as a given.

Tantra yoga is fundamented in the “Science of Breath” that deals with the “respiration” of the Demiurge in the manvantara, a period of time during which the Worlds are manifested by the rhythmic movement of the five Pure Principles or tattvas of the Universe. In man, in his biological body, all the cosmic processes are reproduced and the five tattvas intervene analogously; and also, in his sexual differentiation, the duality that characterizes nature is dramatically reflected. But the function of sex in the Paśu was defined from the beginning by reproduction, and no other purpose outside of that was ever envisaged.

In other words: the human body is the concrete expression of a Manu Archetype that develops throughout an Age, in the framework of a “root race”; in said Archetype, sex fulfills, *from the beginning*, a reproductive function; hence in the body of the Paśu (or of the lost Virya), sex fundamentally aims at reproduction and a proof can be seen in the synchronization with the lunar rhythms that the woman’s period of fertility exhibits: the sexual function is thus seen to be connected to the rhythms of the Great Breath and bound to the process of the Manu Archetype.

Only the incorporation of the Hyperborean inheritance into the blood of the Paśu has made it possible for *the idea of giving sex a meaning other than mere animal reproduction to arise*. An

99. Starting from traditional texts such as the *Kulārṇava Tantra*, the *Tantra-Kaumudi* by *Devanātha Thakkura*, the *Shakti Sangama Tantra*, the *Sātvata Tantra*, etc. One should also read the books by *Jean Marquès-Rivière*, *Le Yoga tantrique hindou et tibétain* and *Rituel de magie tantrique hindoue*; by *Arthur Avalon*, *The Serpent Power* and others; by *Omar Garrison*, *Tantra: the Yoga of Sex*; the classic by *Rama Prasad*, *Nature’s Finer Forces: the Science of Breath and the Philosophy of the Tattvas*; and all the works of *Miguel Serrano*.

idea which, on the other hand, would have been inconceivable for the wretched Paśu.

There have been many Hyperborean methods of harnessing sex for the “strategic reorientation” of the Virya in the millions of years that the Spirits have been in captivity. Tantra yoga is only the latest of these, which the Hyperborean Wisdom has taught for the “Kaly Age,” and which has been subjected to terrible cultural confusion by syncretism with Buddhism, Samkhya dualism, Vedanta monism, the equating of forces with the myths of the Hindu pantheon, etc., etc. Today, tantra is an unrecognizable philosophy, from the point of view of the Hyperborean Wisdom, which the Synarchy has launched in the West as one more of its commodities. But what makes it particularly harmful is the practice of sexual yoga without possessing the ancient symbolic keys, especially the Hyperborean concept of the “yogini” or woman tantrika, which is the main condition for yoga to fulfill its aim.

Many imprudent persons, in the West, throw themselves into the practice of yoga without realizing that such exercises are a minimal part of a philosophy of life or way of life that in the East is cultivated from birth to death. When it comes to yogas that only tend to strengthen mental concentration or physical vitality, the danger is no greater; but when one comes into contact with igneous energies as in tantra yoga, the situation changes unfavorably for the health of the imprudent one.

However, we are not going to condemn the practice of tantric sexual techniques, but to indicate *when a Westerner can resort to them* without danger, given that they form part of the Hyperborean Wisdom.

First of all, let us recall that “strategy is a Hyperborean Virya’s way of life” and that “strategy is a means to an end.” The declared end of the Hyperborean Viryas is: the return to the Origin. The conquest of this end implies different steps: the “awakened Virya” is the one who has glimpsed the Origin and has oriented himself; in the search for the Vrīl he can follow any of the seven ways of liberation that are heard in the Song of A-mor of the Hyperborean Siddhas; one of such ways, that of Strategic Opposition that the Berserker initiates of the SDA were using, we have already mentioned and will refer to it at special length hereafter; but tantra is another of the secret ways of liberation and, therefore, pursues the same declared

end: to awaken the Virya and lead him to the Origin, to the conquest of the Vril.

How does tantra propose to fulfill this objective? By transmuting the physical body of the sadhaka and immortalizing it during the practice of maithuna, the sexual act; thus freeing it from Karmic chains and enabling the consciousness of the Hyperborean Spirit to manifest in it; having reached such a state, with his body of Vajra and his awakened gnostic consciousness, he is already a Siddha, a being capable of applying the pure possibility that the Vril offers and abandoning, if he prefers, the material Universe.

This is the true aim of tantra and those who only take advantage of its practices in order to obtain greater pleasure from the sexual act are mistaken.

We were just recalling that the Hyperborean Virya's way of life is "strategic." If tantra is considered as a "strategy" for the return to the Origin, then there is no inconvenience for the Virya to incorporate tantric techniques into his own strategic way of life. If he does not lose sight of the aims of any Hyperborean strategy, tantric practices cannot harm him; but it is important to clearly establish when it is appropriate to follow this path and when it is not (for the Western sadhaka). For this we will refer to the fundamental technique of "wet-way" tantra: the retention of semen during orgasm.

Maithuna or sexual union is, in tantra, the culmination of a ritual and this ritual is reached after a long philosophical and practical preparation. Especially, one learns to control the breathing and heart rate at will and then to distinguish the nadis or internal energy channels, and the chakras or energy vortexes. The main chakras are seven, located more or less at the level of the plexuses, on a major channel, called Sushumna, which runs parallel to the spinal column.

From the lower chakra, Muladhara, depart, alongside the Sushumna channel, two minor channels called Ida and Pingala, which helicoidally wrap around Sushumna, crossing at each plexus under the remaining chakras. The sixth chakra, Ajna, is located between the eyebrows, above the pituitary gland, and here also converge the Sushumna/Ida and Pingala channels. Above the Ajna chakra is the Sahasrara chakra, Brahmachakra or Brahmarandhra, of which we will speak shortly.

We are mentioning what is strictly necessary for our explanation, but, naturally, additional knowledge is required to comprehend it, which can be acquired in specialized works.

Coiled in the Muladhara and obstructing the Sushumna channel is the “Kundalini serpent,” i.e., the igneous Shakti, the expression in the physical body of the Demiurge’s plasmating potency.

The declared *exoteric* objective of all yoga is to awaken Kundalini and make Her rise through the Sushumna channel, from chakra to chakra, to the higher Ajna-chakra center. From there, the force of Kundalini will allow one to extend the consciousness to the other subtle bodies of man and reach the Sahasrara or thousand-petalled lotus, where the fusion with the Demiurge Brahma is achieved, by means of a “leap of consciousness” toward absolute immanence. With the consciousness in Sahasrara, one achieves an ecstasy that consists, paradoxically, in the dissolution of the individual consciousness, after its fusion or identification with the “cosmic consciousness,” that is: with the Demiurge. For Hyperborean tantra, this exoteric objective, the state of trance or Samadhi and the fusion with The One or Nirvana in Sahasrara, is simply a suicide.

The esoteric objective of tantra, as we have already said, is the same as that of every Hyperborean strategy: the mutation of the Paśu’s animal nature into the divine and immortal nature of the Siddha. That is why it should be very clear that *the Hyperborean Virya, by means of tantra, does not seek any fusion with the Demiurge but, on the contrary, seeks to totally isolate himself from Him in order to gain the absolute individuality that the Vrīl grants*. Can the esoteric objective be achieved by means of tantric yoga? Yes, as long as one has a clear idea of “what” “awakening Kundalini” signifies and “for what” and “when” one can safely resort to the techniques of seminal retention in the maithuna. Let us go in parts.

Many confused Viryas in the West, who are accustomed to imprudently playing with the tattvas, believe that “awakening Kundalini” is something like setting in motion a reflexive energy, which acts on its own, following some unknown law. Contributing to this error is the idea that the Sushumna and the other nadis are “channels” and that, therefore, “they must channel the energy through a kind of circuit, without being diverted or overflowing,” analogous to the “circuits” of the ner-

vous system. It is also believed that the substance of Kundalini is a “fire” or a “heat” or, in any case, the force of a natural energy. But Kundalini is much more than these beliefs.

We will resort to a concept of the Hyperborean Wisdom in order to define Kundalini; but let us bear in mind that it would require several books in order to base this explanation on the “essence” of Kundalini and that, according to the criterion followed here, it is much more brief, and suggestive, to refer to Her by analogically describing Her “behavior,” which does not conform, evidently, to that of a blind force.

We have already said in the “Novel,” in speaking of the Acoustic Kabbalah, that “In truth the Universe has been made from a number of different elements, no more than twenty-two, which support, by their infinite combinations, the totality of existing forms.” These twenty-two elements (or fifty, according to the Indian Traditions), may be considered as sounds or “bījas,” i.e., universal acoustic roots. In this way, it turns out that every “form” comes to be sustained by a “name,” which is the formulation of a determinate combination of the main bījas. But, as we said elsewhere, a “concrete form” is the expression of a “state” in the evolutive process of the Archetypes. There is, then, a relationship between the Archetypes and the “sacred names” of all things, which is worth knowing.

At first, the Archetypes are “thought” by The One Demiurge (Brahma) and projected into the “great primordial psychic ocean” or “Akasha,” where they remain in a potential state. It is the Breath of The One, that is: the utterance of the “names,” the impulse that initiates the evolutive process of the Manu Archetypes that, by unfolding in matter, determine the existing forms; forms that progress toward entelechy, toward a more complete manifestation of their own Archetype. It is true, then, that a secret archetypal name corresponds to “each thing”; a concept that is always handled by magic and that is deeply elaborated in the philosophical systems of India, but which, fundamentally, constitutes the basis of the Acoustic Kabbalah.

When the Demiurge pronounces the Words, i.e., modulates His Breath, He acquires the aspect of a cosmic Verb or Logos. Because of the characteristic that space possesses of being an expression of the archetypal monads, the manifestation of which are the psychophysical Quanta of energy, trutis, or UE-VAC units, the Breath of the Demiurge, His Words, reach all

the points of the cosmos, making it possible to plasmate forms wherever matter allows the evolutive processes of each particular Archetype. This interpenetration is evident in the microcosm of the human body, where all the processes of the macrocosm are reflected. We will especially mention that part of the microcosm that represents the “Logos” or “Verb” aspect of the macrocosmic Demiurge: Kundalini.

Kundalini is, in the human body, the creator Logos or plasmator of forms, an analogous expression of the Solar Logos or Cosmic Logos. She is “asleep” because the microcosm *has already been created*, and She evolves by following the process of the Manu Archetype of Her race. But the main reason for the Kundalini’s inaction is the rhythmic synchronization of the microcosm with the macrocosm of The One; for such a synchronization signifies that there is a simultaneity of processes and that the evolution of the microcosm will not deviate from the archetypal process.

Being by nature a Logos, the “awakening” of Kundalini will involve the pronunciation (japa) of certain names (mantras). In effect: during the ascent through the Sushumna channel, and at its “rest” in each chakra, Kundalini *constantly* recites bījas and mantras as befits an authentic Logos, thus fulfilling a function of superior quality to that which vulgar belief attributes to Her: “igneous energy,” “serpentine fire,” etc.; but in all cases: a force of reflexive action.

This “Logos” nature is that which is responsible for the fact that all yogas that propose the exoteric goal of “awakening Kundalini” end in the “fusion with the Demiurge”; in the absolute identification of the “ego” with the cosmic One. This effect is due to the “harmonizing” or synchronizing function that Kundalini fulfills upon *repeating the names* (bījas or mantras) *of each part of the physical body* (and of the subtle bodies) *and verifying that they correctly reflect the cosmic processes*. Through this “behavior” of Kundalini, the yogis who effectively seek to attain Samadhis or contemplative ecstasies, and even the fusion with The One, achieve astonishing results; it must occur this way, from the moment at which the Logos, awakened in the microcosm, faithfully reproduces the bījas of the Cosmic Breath, equilibrating all the disharmonies and synchronizing all the biological rhythms. It will now be understood why we were qualifying the pursuit of the exoteric objective of the yogas (awakening of Kundalini) as suicidal for the one who seeks

absolute individuality: *because it increases the material enchainment of the Virya even more.*

It must be made perfectly clear, then, that Kundalini *must not be awakened* unless one possesses the keys to harness Her *re-creating* power, for *Her Verb* can represent both the Will of The One, *in the microcosm*, in order to ensure evolution, and one's own will, in order to produce the mutation.

The Hyperborean Wisdom assures that Kundalini has the "secret mission," among others, of immediately intervening "*if the natural nexuses between the microcosm and the macrocosm are altered, from the microcosm, by yoga practices; in that case, Kundalini will attempt to re-establish the nexuses by completely re-creating the bodies* (physical, emotional, mental, etc.) *of the microcosm in order to connect or re-connect it with the Demiurge; but if this is not possible, Kundalini will attempt to destroy the microcosm, since it no longer complies with its destiny of evolving toward the entelechy of the Manu Archetype.*" One realizes, then, the danger that a Hyperborean Virya, *who hates the work of the Demiurge*, exposes himself to if he "awakens Kundalini" and She plunges him into a nirvanic ecstasy: it is possible that madness or some serious injury to his physical or subtle body may derive from this. That is why the Hyperborean Wisdom tells the Virya who plays with yoga:

"what will you do, you who still believe *that sex 'is bad,'*
when Kundalini says *Lam*
and your gonads *dry up?*

and: "what will you do, you who still suffer *anguish and fear,*
when Kundalini says *Vam*
and your adrenal glands *dissolve?*

and: "what will you do, you who still *suffer and rejoice*
for the things of the world,
and still feel the *fire* of anger
and the *coldness* from indifference,
when Kundalini says *Ram*
and your pancreas *calcifies?*

and: "what will you do, you who still *love and hate,*
when Kundalini says *Yam*
and your heart *explodes and volatilizes?*

and: "what will you do, you who still *speak and listen,*
when Kundalini says *Ham*
and your thyroid *disintegrates?*

and: “what will you do, you who still *see without seeing*,
when Kundalini says *Om*
and *your death* ensues?”

These questions, and many more, the Hyperborean Wisdom asks the Hyperborean Virya, i.e., *the one whom the Demiurge will take as an enemy* and attempt to destroy. However, the answer does not imply *abandoning* the practice of yoga “*a priori*” but, as we said before, to operate strategically with the tantric techniques after knowing “what” it means to awaken Kundalini, (something that we have already explained) and “why” and “when” one can resort to the techniques of seminal retention in the Maithuna without danger. We must investigate, then, these last two conditions.

In order to know, with exactitude, “when” a Virya can successfully use the sexual techniques of Tantrism, it is necessary to start from a fundamental affirmation of the Hyperborean Wisdom: the sadhaka *should not love the woman of flesh*¹⁰⁰ “*with the heart.*” This revelation will surely be taken with surprise or disdain by those who perform tantric practices “with the beloved woman,” a figure very dear to the Western fantasy. To those who proceed in this way, the Hyperborean Wisdom calls them, simply, “ignorant Viryas,” for “they ignore everything about Kaly.”

It truly causes laughter to think that ignorance goes so far as to believe that in the Maithuna with the “wife” (or “friend” or “lover”), one will find the liberation that the sacred Eastern texts promise: this is to have a poor idea of Shiva and Kaly. But the laughter ends here because such an ignorance is extremely dangerous, since, for a Western couple, the results are usually disastrous and it is more likely that instead of the longed-for “liberation,” what is obtained are irreversible psychic alterations.

One should not, then, love the woman with whom one joins in order to practice tantric Maithuna; but, then, what feeling should one feel toward her? *No feeling.* We have posed this question in order to emphasize the difficulty that exists in the West to conceive of a *non-affective* relationship with a woman, a difficulty that does not present itself in the minds of those

100. The *woman of flesh* is the one whom the Hyperborean Wisdom also calls the *Eve-woman*. Further on these denominations are clarified, but here, the “woman of flesh” is to be considered as a “common woman” or “Paśu woman.”

Easterners *for whom the tantric method was revealed*. But we are not dealing here with a “racial” differentiation of biological origin, which manifests itself in different psychological attitudes toward sex and women, but with an “acquired character” by Westerners, which captures a precise moment of historical appearance: the thirteenth century.

Concretely, they were the Cathars who, in the framework of their A2 Strategy, planned the collective mutation of Western civilization and launched, for this purpose, the troubadour movement.

The Cathars had two problems to solve. The first, which we will come back to, was that the Benedictine Druids with their Gothic revolution based on the Acoustic Kabbalah produced some infernal machines that had, and have, the power to “at-tune” the inhabitant of Europe to the psychoid Archetype of the Hebrew Race that, as we said, was updated by Jesus Christ. These stone machines are the Gothic cathedrals; and the Strategy of the “pure ones” was, first of all, aiming against this plasmating power. The second problem was that, as the Hyperborean Wisdom teaches, “in order to mutate a human community, it is necessary to have an enormous amount of collective psychic energy, subtracted from the process of the Demiurge’s psychoid Archetypes.” It will be seen in the Fourth Dissertation, when studying the laws of the ⚡ Psychosocial Strategy, that such an energy must be “contained” in a psychoid Archetype or egregore *constructed for such a purpose* by Berserker initiates duly instructed in the Hyperborean Wisdom. For now, we are interested in pointing out that, in this case, said Archetype was indeed created by the Cathars and that it was corresponding to *the image of the luciferic woman, Lillith*. But this Archetype was plasmated in the terrestrial psychosphere as an act of war of LúCIFer himself who, *from behind Venus, with the green ray, projected the image of his wife, Lillith*. Thus, the “Dame” Archetype, such is its profane name, was corresponding to a Hyperborean Spirit, *the sex of which is not associated to the function of biological procreation*. Precisely, the energy with which one would feed the Dame Archetype would be obtained from the sublimation that the gentleman would make of his sexual energy by seeking, in common women, the face of the Hyperborean woman, of which the Siddhas’ Song of A-mor speaks in the blood of the lost Viryas. And such is the characteristic of the Dame Archetype, its sexual dissocia-

tion, which the knight can only project on “unattainable,” “distant,” or “alien” women, and never on one who can be easily possessed. This condition is so rigorous that the beloved Dame, i.e., the woman on whom the lover projected the Archetype, is transformed into a “common woman,” “loses her charm,” her “beauty” decomposes when she is “conquered” and possessed. Then love is transformed into pain and the knight, disenchanting, is impelled to once again seek another unattainable Dame whom he will worship and try to conquer. Starting from the plasmation of the Dame Archetype, a tendency to idealize the woman is generated, which has no historical antecedents prior to the thirteenth century.

In the Fourth Dissertation it is demonstrated that a psychoid Archetype can only be consciencialized when it has been *described*. In order for an Archetype that was plasmated without the intervention of the Demiurge to act socially, so that The Dame can be sought, it is necessary for someone to “describe” it, i.e., to reveal it to the people. And that was, precisely, the esoteric mission of the Provençal troubadours: to describe the Dame; to make the European Virya remember the primordial image of the Hyperborean woman; to awaken his Minne. But, in order to describe something, it is necessary to have seen it before. Where did the troubadours obtain their prior vision of the Dame? From their Cathar initiation in the French Languedoc, where they learned the “gai saber” and the “trobar clus.” The Dame, *surrounded by stone enclosures* (towers or walls), who was *described* in love songs is a clear proof of the strategic-Hyperborean origin that the troubadours’ knowledge was exhibiting.

The second problem that the Cathars had to solve was posing the need for European society to have at its disposal a certain collective psychic energy as a prerequisite prior to its mutation. We already saw part of the adopted solution: the plasmation of a psychoid Archetype that would have as its finality to provoke an erotic sublimation in the medieval Virya. It now remains for us to determine in what way this Archetype could be the solution to the second problem.

Let us see what the characteristic mechanism is. When the knight experiences *sexual desire*, he “triggers” the conscious emergence of the Dame Archetype, immediately establishing the *certainty* that the desired woman (whom he can actually “touch” or “possess”) *is not the Dame of his dreams*, the ideal

woman. Seen “from afar,” the woman of flesh is a representation of The Dame; and her contemplation, or the desire for her, feeds the Archetype with energy taken from the libido. But if “the bringing together” is sufficient so as to culminate in sexual pairing, in which the “direction of energy has been inverted,” then the Dame Archetype withdraws, “below the threshold of capture,” and the woman of flesh is left to her own “charms.” When the spell is broken, it is likely that the desire unquenchably increases; but not toward the woman of flesh, who has been devalued by the absence of ideal attributes, but toward another “ideal woman” in whom the Archetype’s process will be repeated. The Archetype “counts” on this reaction, which it itself provokes, in order to be constantly fed: it is its mode of proceeding.

Naturally, the Dame Archetype is a terrible egregore on which the Cathars were relying to store sufficient psychic energy so as to achieve, by means of its instantaneous discharge when it suited the A2 Strategy, the collective mutation of countless lost Viryas into immortal Siddhas. The failure of the A2 Strategy, and particularly the destruction of the Cathar elite at the stakes of the Druid Pope Innocent III, *prevented the egregore from being discharged in time and deactivated* after a Psychosocial Strategy esoteric operation known as *archetypal metamorphosis*. Since then, the egregore has not ceased to feed in a sort of symbiosis, so close that it has ended up irreversibly modifying the conduct of the “Western” lost Viryas. But, without the control of the Cathar initiates, who had “directed” the conduct of the egregore, its action has ended up being nefarious, far from inspiring those beautiful images of the Hyperborean woman that were preventing the woman of flesh from being loved. On the contrary, the passing of the centuries, the numerical increase of the population and certain cultural processes have modified the profile of the Dame Archetype, which has finally converted into a monstrous vampire, responsible for many of the neuroses that the contemporary Virya suffers from. In order to favor its entelechy, it has forced the idealization of the woman of flesh to the point of exaggeration, succeeding in completely idiotizing the Westerner, who has now associated “the duty” of experiencing a “love” that no one knew before the thirteenth century, with the sexual act.

The modern Virya, imprisoned in the web of feelings and tenderness, will no longer know how to distinguish the

woman of flesh, for she is now hidden under the guise of her archetypal projections. And the woman of flesh, ontologically confused by the idiotized masculinity of the Virya, will slip out of his control, will veer erratically between her own sexual limits and, in the end, will masculinize herself, in an unconscious attempt to avoid the projection of the Archetype. The Virya will then suffer countless sexual disorders, from impotence and dissatisfaction to homosexuality, since the latter, so prevalent among the current male population, is the effect of a permanent capture of the ego by the Dame Archetype, who thus absorbs the totality of its available energy.

Of course, after the failure of the A2 Strategy, the decontrol of the Dame Archetype has been capitalized on in favor of the Synarchy Strategy by the Demons of Chang Shambhala, especially in order to reinforce the collective influence of Jesus Christ, who was thus converted into a perfect mirror so that the Viryas might find the beloved image and sublimate the energy that the Archetype needs in order to continue its process. Of course, the image of Jesus became feminized to the same extent that the woman of flesh became masculinized; but this is of little concern to the Synarchy, since it does not affect the “non-Christian” peoples, the main one of which is the Hebrew “Chosen Race.”

The descriptive action of the troubadours was circumscribed to the European ambit¹⁰¹ and that is why it did not affect Asian communities, where tantric techniques flourished until the eighteenth century, that is, until the time in which “European civilization” descended upon Asia and the Viryas of India and Tibet were astonished to find that the European man did not know the woman of flesh. But the damage was already done; in order “to progress,” the Asiatic had only one way: to imitate the European; i.e., to love and respect the woman of flesh, *only one in life, and to desire all the others, sublimating the energy of Eros*. In this way, Asiatics would also lose sight of the woman of flesh and would end up, except for the most hermetic tribes, completely idiotized, confusing Kaly with the terrestrial Shakti, with Mother Earth or Matter. From this catastrophe concludes the beneficial influence of tantric

101. We do not attach much importance to the influence that the troubadours may have exerted in the East during the Crusades, since all Western influence there was swept away by the Arab and Turkish expansion of Islam from the thirteenth century onward.

yoga; since it requires, for its realization, *to clearly distinguish between the woman of flesh and the Hyperborean woman*. And such a distinction, it is not superfluous to repeat, cannot be made “if one loves the woman of flesh with the heart.”

So we come back to: “when” can a Westerner use tantric sexual techniques *without danger*?

We start, in order to find out “when,” from an affirmation of the Hyperborean Wisdom: “the sadhaka must not love the woman of flesh with the heart.” Now we know why: the “love” that one experiences for the woman of flesh is a conscious expression of the evolutive process of the Dame Archetype, which masks her and prevents one from knowing her “true Face.” But the Dame Archetype has acted freely for more than seven hundred years, producing the incorporation of hereditary characteristics into European lineages, especially the “modulation” or “profiling” of the unconscious “anima” according to its image. And also considering that the egregore is at present tremendously potent, *it must be undisputedly admitted that, in the West, it is very difficult not to love the woman of flesh*.

It is comprehensible, then, that there are Viryas who find it virtually impossible *not to love* their women of flesh; and this need not be a cause for concern *if, in that case, they prudently abstain from practicing Tantrism*. But what should the lost Viryas of the West who seek “liberation” from material chains do then? The Hyperborean Wisdom advises that they resort to the other secret ways in order to undertake the return to the Origin, *if they are still capable of loving the woman of flesh*. This advice should not be disregarded; the risk is enormous: by the inverse path of return, following the Voice of the Pure Blood, one succeeds in *re-integrating the ego with the Self*, bringing the present consciousness to identify with the Spirit or Vril and, in a *gnostic burst, transforming itself into an “absolute individuality.”* On the contrary, an improper use of Tantrism may lead to a nirvanic samadhi in the Sahasrara that involves a harmonizing physiological re-creation by the Kundalini and an identification with the Demiurge: the “fusion with Brahma”; in this case, after the “bad trip,” the consciousness of the Virya would not remain re-integrated but fragmented into a permanent schizophrenic state from which it will be difficult to recover.

The Family Test



naturally, there are an infinite number of different situations in which lost Viryas can find themselves, from those who have already “formed a family” and love their wives as good Christians, to those who are completely ignorant of their capacity to love: how will they know “when” they can resort to the sexual practices of Tantrism *without danger*? We will answer that there is indeed an infallible way to know “when” that moment has arrived: it is the Family Test, proposed by the Hyperborean Wisdom. With the exposition of said Test, we will end the series of warnings that we have been making about the dangers of Tantrism.

The Family Test does not specifically refer to sex but to “blood relatives,” parents, siblings, grandparents, uncles, aunts, daughters, sons, etc. But whoever is able to face the Family Test will not only see his questions about sex answered, but will have taken an important step toward other ways of liberation, apart from Tantrism. That is why every Western Virya should face this test sooner or later.

It is known that the genealogy of a family can be gratified by establishing analogical correspondences with the figure of a “tree,” in which the “trunk” and the “root” correspond to the ascending stirp, and the “branches,” to the different lineages that descend from the main trunk. As an example, we represent, in Figure 3, the family of Mengano, brother of Perengano and son of Montano, who, in turn, descends from the Hyperborean trunk of the Villanos. As useful as this analogy seems to be for determining the ascendants of a lineage, the degree of kinship, or the proposition of an inheritance, it is, however, insufficient from the strategic point of view. To demonstrate this, it is sufficient to point out the static (in fact “unalterable”) character of the schema: “a genealogical tree is, like the vegetal tree that it represents, a concrete and unmodifiable fact *because it faithfully refers to events that have already taken place*”; such is the current opinion. The schema being unmodifiable, the insufficiency is highlighted when Mengano, e.g., proposes the strategic model of “increasing” the influence that the Villano’s inheritance exerts on himself. From the analogy with the “tree,” one cannot deduce how this would be possible:

GENEALOGICAL TREE: VILLANO STIRP

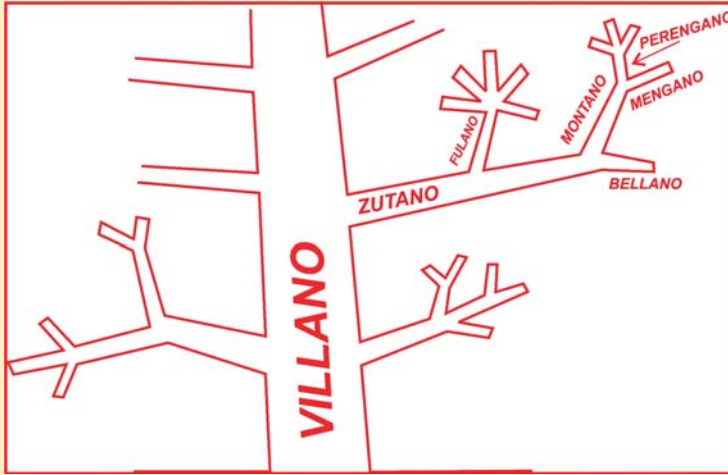

Figure 3

Mengano cannot be a branch and a trunk at the same time; if he is a branch, he is not a trunk; if he is a “Mengano,” the blood inheritance of the Villano stirp is that which the schema shows: a quarter of the original blood. With this analogy there is, then, no solution; that which was born a branch cannot *grow to be a trunk* and its function is certain: *to remain comfortably in its place*.

One can overcome the insufficiency of the schema by resorting to another analogy, this time not conventional, but first it is worth clarifying that a “genealogical tree” constitutes the elementary description of a psychoid Archetype called “familial Archetype.” The “genealogical tree” represents, then, the superstructure of the “familial fact,” which evolves toward the entelechy of the familial Archetype. But a “family” is defined by the living members that it exhibits in each epoch, rather than by the past of its lineage, because *all living relatives are a concrete expression of the archetypal process*. We will give an example. Let us observe the tree of the Villano stirp; we discover that in 1910 nineteen relatives of that blood were living; *the nineteen relatives, each and every one of them, are concrete expressions of the familial Archetype*: they are evolutionary “tests” or “trials” that *the biological mode of the process* requires in order to concretize the entelechy of the familial Archetype.

Every family or lineage tends toward the entelechy of a particular familial Archetype that is, in turn, a hypostasis of the

Manu Archetype. And every Virya, at the heart of his own family, inevitably evolves in that direction. *One cannot escape the process by externally reacting*, e.g., by abandoning the family, shutting oneself away, ignoring it, destroying it, etc. Even if all the relatives have died and only one Virya survives, the familial Archetype will continue the process through him. The only way for the lost Virya to avoid evolution *is interior, it passes through the blood and leads to the past*. And we have already sufficiently explained how this interior path must be sought in the memory contained in the Minne.

But Mengano has also realized that by continuing in his role as a branch, he only succeeds in evolving in the direction of the familial Archetype. Looking back, he understands that he descends from a purer Hyperborea stirp and the problem of *recovering* an inheritance that lies in the past is posed. As there is no evidence, from the genealogical tree, what the solution can be, as we said, Mengano decides to turn to the Hyperborean Wisdom, the teachings of which affirm that the “Pure Blood” is the only container of the Hyperborean inheritance. For the Hyperborean Wisdom, an analogical schema starting from the Pure Blood should not topologically vary from the already-seen genealogical tree. But in place of a tree, it considers that *the blood is equivalent to a river* of which the main channel is the “trunk” of the genealogical tree, and its rivers and streams, affluents or tributaries, are represented by the branches.

Let us go deeper into this new allegory. When, now looking at Figure 3, we see the “Villano River,” into which flow numerous tributary branches, among which stand out the rivers “Zutano,” “Montano,” and “Mengano,” connected in such a way that each one channels the flow of the previous. But the *flow* of the rivers is analogous to the *purity* of the Blood. The Villano River, by representing a purer Hyperborean Blood, has consequently a greater flow, a quality that can be noticed in Figure 3 upon observing the great width of its channel. And Mengano, the Virya who was seeking the inverse path of the Pure Blood, appears in the allegory as a simple stream of reduced flow.

Seen in this light, now the problem of Mengano does not seem to be unsolvable because it is reduced *to the obtainment of an increase in flow, and this is always possible in a hydraulic allegory*. We can pose the strategic problem of Mengano in analogical terms of the hydraulic system by asking: what must

be done to increase the flow of the Mengano stream and, as far as possible, bring it to equal that of the Villano River?

Before responding, it is worth noting that the flow, *by running in an inverse direction*, goes from Mengano to Villano, so that the solution does not lie, as might be slightly thought, in widening the riverbed. Hence, *the only* solution that exists for this problem is: *to add the flows of the remaining rivers to the channel of the Mengano stream.*

In order to completely clarify this hydraulic solution, let us consider only the Mengano stream and the Montano and Zutano rivers, which are connected “one after the other,” that is to say, “in a series.”

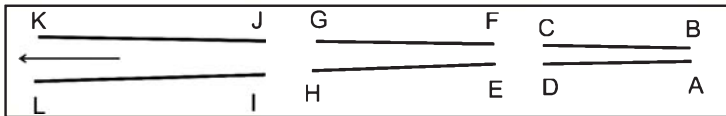

Figure 4

The Mengano is connected “by width” with the Montano, that is: CD with EF; and the Montano with the Zutano also: GH with JL.

The solution to the problem requires altering this connection between channels “by width” and replacing it with a longitudinal connection, in order to “add the flows.”

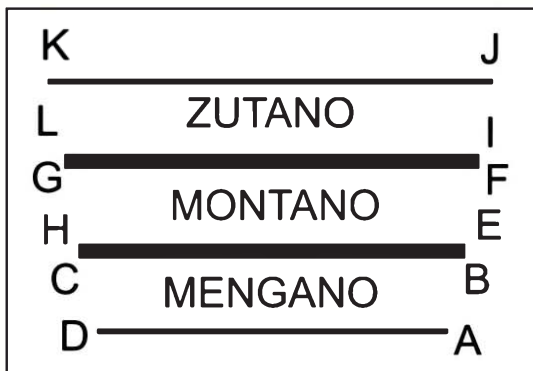

Figure 5

The theoretical layout for the three considered watercourses has been drawn in Figure 6. There it can be seen that the watercourses are now connected longitudinally, “in parallel”; the

Mengano, e.g., has been united to the Montano by the banks CB and EH.

The final result is a new Mengano, with a much higher flow due to the addition of the flows of the Montano and Zutano rivers.

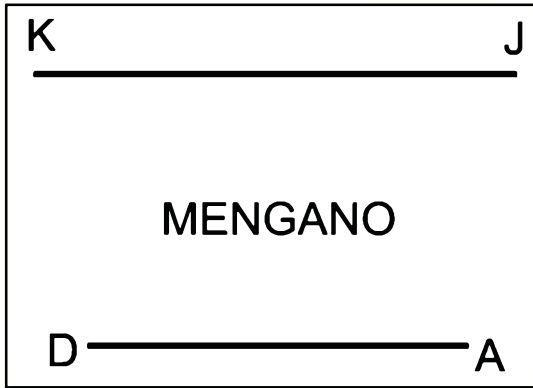

Figure 6

Continuing with this procedure, and after adding *all* the other tributary rivers to the Mengano, it is theoretically possible to parallel the flow of the Villano River, putting an end to the problem.

For now, let us leave the hydraulic analogy and return to the strategic problem of the Mengano Virya: what conclusion can be drawn from the hydraulic solution? What does it mean for the Mengano Virya to “add the flows”? In order to respond, it is necessary to transfer the hydraulic solution to the concrete genealogical plane of Mengano’s family. In it, “the rivers” are equivalent to near or distant relatives and the “sum of flows” signifies that Mengano *will have to incorporate his relatives into himself; to add, to his own blood, the Pure Blood of the other members of the family.*

It sounds insane, but it is appropriate to ask: is this solution possible? According to the Hyperborean Wisdom: *yes*. And the attempt that each Virya carries out in order to make such a solution effective is what is called the “Family Test.”

There is a moment of “transition” in the life of the Virya: when he ceases to be lost because he has become aware of the Great Deception, but he has not yet “oriented himself” and, therefore, he is not completely “awake.” In this difficult trance, the important thing is *to discover one’s own identity*, which is

buried under multiple masks or personalities. It is necessary, above all, to distinguish that part of oneself that transcends the process of the familial Archetype. In order to achieve this, it is necessary to realize two things: on the one hand, one must seek, in the Blood, the memory of the Origin, the Hyperborean Inheritance; and, on the other, to achieve the *re-integration* of the familial Archetype, the pieces of which are scattered throughout the world in the form of “blood relatives.” The Family Test has the object of granting both things, so that the Virya overcomes the transition and encounters a first-rate orientation.

But, although the Family Test aims at favoring the discovery of the true “ego” in each one, and it is certain that this discovery can be sought by another way, where the Test cannot be passed by any other method is in relation to the determination of the “capacity to love.” Let us remember that we were wanting to know “when” it is possible for the Virya to use the sexual techniques of Tantrism without danger, and that the Hyperborean Wisdom told us “one must not love the woman of flesh with the heart.” We have also learned that “love” for the woman of flesh is related to the process of the Dame Archetype. And, lastly, we said that the Western Virya, in the majority of cases, suffers from such a confusion that it is quite possible that he ignores his own “capacity to love,” and, with this, he also ignores when it is appropriate to follow the tantric path. In this case, the conclusion of the Family Test is definitive, because it will indicate to him if he should keep on “loving” the woman of flesh or if he is already in a position to “A-mor” Kaly.

We already know what is expected of it; now we must know what the Family Test consists in. First of all, let us say that said test is absolutely personal, since it aims at reinforcing the individuality of the Virya, and, that is why it has to be practiced by each one in particular, whatever his familial situation may be. From the Virya who is “alone” in the world, to the one who is the offspring of a prolific family, all must start from the principle that the test “only interests him,” is “personal,” “interior,” and even “secret.” Only under such conditions of intimacy and self-respect can the test be faced with a chance of success.

On the other hand, it must be made clear from the outset that the Family Test *is not of a moral inspiration*, that is, it neither saves nor condemns anyone. It only determines the de-

gree of existing dependence with respect to the archetypal processes and makes it possible, in every case, to reduce such a dependence. This clarification is valid because no one but the Virya will be able to evaluate the result of *his personal test* and if it is negative, we want to bring forward that it will be of no use for him to deceive himself: through Tantrism, he will only find bitterness, and it is possible that he will ruin his health and that of his partner.

We now present the Family Test.

Every Virya who attempts this test must begin with a preliminary inquiry: what is my family? Aiming to know where his Hyperborean lineage comes from. The Hyperborean Wisdom provides two laws that must be contemplated when giving the answer:

1° Law - The Hyperborean Inheritance of the Pure Blood is maternally transmitted. This inheritance can easily nullify the process of the maternal stirp's familial Archetype. The answer to the inquiry into the family starts, then, first of all, with the maternal lineage.

2° Law - The familial Archetypes transmit their traits by genetic inheritance. If the mother's Hyperborean inheritance is strong, the paternal genetic inheritance will predominate and, therefore, the paternal lineage's familial Archetype will be what dominates in the intensity of the process. But if the maternal Hyperborean inheritance is weak, then the genetic inheritances of both parents are distributed, just as Genetics teaches. When inquiring about the family, according to the second law, the paternal lineage will appear in second place.

The inquiry, considering these two laws, should at first refer to only the relatives who have lived or live contemporaneously with one's own generation: especially the close relatives, those with whom one has lived and who have most strongly influenced or affected us. Secondly, after this determination, the inquiry will fall on the ancestors; *but only if one has passed the Family Test with the contemporaneous relatives.*

When one has responded to the inquiry and is well aware which are the relatives *to whom the test is to be referred*, the test must be faced with the mind set on the concept that each relative is effectively another expression of the familial Archetype. If this simple truth has not been comprehended, or is not accepted, it is useless to attempt the test.

Once the preliminary inquiry has been fulfilled and bearing in mind the indicated concept, the Family Test can be carried out. *It consists in locating the external relationships that link us with our relatives.* One way to describe the operation of the Test would be to say that it is a *questioning* of said external relationships, but this is not entirely exact; rather it is a matter of *disposing the mind to know* which are the relationships in question. If we are clear about what it is that we wish to know, the answer will immediately emerge in our consciousness, without the need to resort to reasonings or logical approaches.

To be clear about “what we want to know”... we can resort to the following concepts:

- a. By “external relationship,” we refer to those of an affective order (“sentimental” or “emotional”), those purely gnoseological relationships, which come from “learning” that the genealogical tree is a factual fact, being excluded in a first consideration. In other words: we all know what an uncle, a father, a brother, or a cousin is; *we do not refer* to such structural relationships when considering *our* uncle, father, brother, or cousin, but *to what we feel for them.*
- b. Any affective charge is, evidently, an “internal” content, proper to the psychic sphere. Why, then, do we call the affective relationship with relatives as “external”: because the existence of “affects” between relatives who share the same familial Archetype is purely illusory and because the support of this illusion is rooted in the “exterior world.” We must distinguish, then, between the “true” affects that we feel toward other persons or things and the “external (affective) relationship” that we believe to experience for our blood relatives. Let us explain how this confusion originates.

It is clear that every affective charge comes from a subject-object relationship, established from the differentiations of the ego. By the effect of objectivation, any thing is susceptible to possessing an associated affective charge, which, in many cases, it will not be possible to separate from the thing itself. But the Virya is normally inserted into a cultural superstructure where he plays his dramatic role and from where he gathers his external experiences, which, to a greater or lesser extent, constitute “internal” affective relationships. If the object of attention is another person, who also integrates the superstruc-

ture, the confrontation of one's own cultural structure, and that of the neighbor, produces a mutual affective relationship that is called "Karmic" because it is transferred from the personal collective unconscious to the universal collective unconscious, i.e., to the psychosphere, where it is plasmated as a *relationship between psychoid Archetypes* and from where it *causes* subsequent "Karmic" effects. In the drama of life, a Virya can love or hate another, or be loved or hated by the latter, and attribute to such affective relationships the characteristic of a concrete bond, given that they are consistent and effective within the superstructures (if they "exist," their "existence" can be proven) and even generate future Karmic reactions. The relationship of hate or love with the neighbor constitutes a "concrete bond" that cannot be denied, since it involves the weight of the affective charge on the consciousness, each time that it refers to the neighbor.

Does the same occur with blood relatives? It is usually believed that it does, but we will soon see that this is not so. In the first place, let us remember that every affect must be *referred to an affective object*, which has been differentiated and with which a relationship has been established. But, relatives being the expressions of the same familial Archetype, can they be considered as affective objects just like any person whom one loves or hates? The Hyperborean Wisdom affirms that a blood relative is an "object" to the same extent that the "ego" is an object when it questions, "what is the 'I'?"¹⁰² and it places itself as the object of its own questioning. In this case, the ego performs a reflection, a splitting of itself, in order to be gnoseologically "observed"; but, no matter how effective the objectivation of the self may seem, the result of the inspection will always be subjective, impossible to verify by anyone other than the reflective ego; that is why we call "illusion" to the "object" produced by the reflection of the "ego" on itself. Now, according to the Hyperborean Wisdom, blood relatives are "reflections" of the familial Archetype and, therefore, in this sense, the term "illusions" also befits them. In every case, we should rigorously qualify the "affective," and even the cognitive, relationship that we believe exists between us and our blood relatives as "illusory."

102. Asking from the first-person perspective, "what am I?"

- c. Of course, it is very difficult to transcend the barrier of this illusion, but no one said that passing from “lost Virya” to “awakened Virya” was an easy task. And, we can assure: whoever has not become independent from the evolutive process of the familial Archetypes will find his Strategic Orientation very difficult. However, such an “independence” is not acquired by *denying the problem*, i.e., by rejecting or ignoring the structural function of the family, but, simply, becoming aware of the situation and facing the Family Test.

The first obstacle to accepting that relatives *are not* true affective objects is the fact that these relatives actually appear as objects in the exterior world. And in the face of such a concrete presence, the assertion that they are mere illusions seems to be groundless. But the reality is this: our relatives, like ourselves, are true objects *for the other*; relatives *to each other*, are expressions of the same subject: the familial Archetype; and none of them can be considered an “object” of the other except in a “reflective” capacity.” A second obstacle that prevents us from accepting the illusory character of familial objectivity comes from a phenomenon called “feedback by mutual capture.”

This phenomenon, characteristic in the evolutive processes of familial Archetypes, is responsible for the belief in “external relationships” (affective) between blood relatives. In order to comprehend its behavior, let us recall what we said pages ago about the Manu Archetypes that sustain the superstructure of a cultural fact: “The cultural fact is developing, impulsed by a great potency, *whether the observer notes it or not*, and in that march toward entelechy the superstructure *takes what is necessary for its perfection and rejects that which is useless or opposed to it.*” The familial Archetype proceeds in the same manner because, through the members of the “family,” it attempts to accommodate itself to the superstructure by occupying the places that the Karmic relationships leave vacant and by adapting itself to the Manu’s evolutive processes. This is how relatives come to play a determinate role in the drama of life from which they must not depart under the penalty of being excluded from the superstructure (which would imply that the familial Archetype ceases to evolve through the “expelled” or disincarnated relatives). In order to fulfill their given roles, the relatives do not have to suspect that they are all expressions of

the same Archetype and, on the contrary, they must establish “external relationships” with each other, often passionate and dramatic, as it suits the “Karmic directions” of the superstructures. With the purpose of affirming the relatives in their roles, and of confirming the illusion of their objective and different existences, the familial Archetype produces the phenomenon of feedback by mutual capture.

We already know how the “capture” is produced: by matching one’s own cultural structure up against the superstructure, in order to “know,” the psychoid Archetypes, which sustain external cultural objects, *modify the relief* of these objects by favoring the projection of the interior cultural premises onto the exterior objects. That is why every cognitive act of an exterior object is in reality the *recognition*, or awareness, of an interior object projected into the world. There begins the “capture” because the exteriorization of interior objects implies the participation of the superstructure in evolutive processes, its integration into the cultural fact. This effect is sought by the psychoid Archetypes in order to obtain the energy that they use in their development. In summary: “the psychoid Archetypes *feed* (take energy for their evolution) from the cultural structures (the Viryas), whom they manage to *capture* in the superstructure.”

“Mutual capture” is produced when two relatives confront, within the dramatic framework of a superstructure, their cultural structures in order to gain reciprocal knowledge of themselves. Here, the familial Archetype, which is psychoid, makes a double capture because both relatives are expressions of their own evolutive process. Let us suppose that the relatives are Mengano and his brother Perengano. Mengano looks at Perengano as a “cultural object” and projects on him an interior image; but it has been the mutual familial Archetype that *adapted* Perengano (as the “little mirror” of the allegory) *in order to receive the projection* made by Mengano; and it does so *with a Karmic criterion*, so that the “external relationship” established between Mengano and Perengano adapts to the drama of life, i.e., to the “Manu” process of the superstructure; Mengano *recognizes* that what he feels for Perengano is *hatred*: that relationship makes it possible for the greater potency of an “object” (Perengano), integrated into the superstructure, “to capture” the cultural structure (of Mengano) in the process of the psychoid Archetype that evolves in the “object”; once the

capture is produced, every Archetype is fed with an energy taken from the captured subject: but in this case, the Archetype that sustains the object (Perengano) also sustains the object (Mengano), and the energy that it takes from Mengano in order to develop the entelechy of Perengano *is its own fed-back energy*. If we consider that Perengano has also “looked” at Mengano as a “cultural object” and from this examination concludes that he experiences pity, we can comprehend that, reciprocally, the familial Archetype will feedback energy from Perengano toward the evolutive process of Mengano. There has occurred, then, a phenomenon of “feedback by mutual capture,” which has the purpose of creating, between relatives, the illusion of external relationships (affective).

The process of the psychoid Archetypes in the superstructure constitutes a drama for those who are subject to it and must play a role. And in that drama the blood relatives have to behave as if they were truly particular individuals, in order to ensure the development of the plot. That is why they ignore that they are all one and believe that true affective relationships exist between them. For what is that hatred of Mengano and that pity of Perengano but the illusion of the external affective bonds that cause the double capture? It is as if someone ordered his left hand to hit his right hand and a witness, who only saw the hands, affirmed that the left hand “assaults” the right. The hands do not act separately, although appearances indicate the contrary, because they form part of the same organic structure and both obey the brain; in the same way that the relatives, even if they believe to hate or love each other, do not act separately because they form part of the same familial superstructure and all of them “obey” the process of the familial Archetype.

- d. We said that the Family Test “consists in locating the external relationships that link us to our relatives” and, in the preceding commentaries, it was made clear that the “external relationships” are the diverse affects that we hold toward them and that such affects constitute an illusion. With these clarifications, and remembering that a “questioning,” in our concept, does not refer to a logical construction, but to a psychic disposition in order “to know.” We can also say that: “the Family Test consists in responding to the question: what do I feel for my relative, Albano?”

In the form of a questioning, the Family Test may be more accessible to the Westerner accustomed to thinking rationally, as long as one remembers that the questioning aims at ascertaining the existence of “external relationships.”

- e. Taking into account what the 1° and 2° law say, the Family Test can be faced by questioning the relatives selected in the preliminary inquiry, i.e., the contemporaneous ones. The procedure of the Test is the following: Question: what do I feel for Uncle Albano? Answer: “hatred” or “love” or “affection,” etc., or an indefinable sum of affects. In principle, the quality of the affect does not matter: *if any type of affect exists, it signifies that the archetypal process has illusorily established a Karmic relationship.* In that case, the Virya should not move forward with Tantrism and should be careful in undertaking the other Hyperborean paths of liberation, *for he is not yet prepared to initiate the search for the center.*
- f. But, from the analogy established between the “family” and the hydraulic network of Rivers, the conclusion was drawn that the Mengano stream can increase its flow until approaching that of the great Villano River by adding the flows of the remaining tributary rivers with his own. This conclusion was analogically expressed by affirming that the Mengano Virya will be able to purify his blood, to the degree of paralleling his Villano Hyperborean Ancestor, to the extent that he succeeds in re-integrating into himself the familial Archetype, the pieces of which, in the form of blood relatives, are scattered throughout the world.

If it is possible to re-integrate the familial Archetype, one will have to begin by eliminating that which constitutes the illusion of separation, that is to say: “external relationships.” The Family Test will allow us to locate the affective relationships with our relatives; the *reciprocal identification* will make it possible to reduce them.

Before explaining how to reduce external relationships, we will give a warning. We realize that it will be difficult for many Viryas, who have relatives for whom they experience sentiments of contempt or repugnance, to accept that they form part of a single entity in which they are also included. If such is the case of the lost Virya, who upon facing the Family Test

discovers that a whole universe of passions binds him to his blood relatives, the Hyperborean Wisdom tells him that nothing prevents him from continuing to evolve within the Plan of the Demiurge. If his passions tie him to illusion and he does not feel capable of overcoming them, it is useless for him to prick up his ears, for he will never hear the song of the Sidhas, nor will his Spirit come forward from the Origin in the Blood Memory. The Hyperborean Wisdom, on the other hand, does not impulse the Virya to stop feeling fondness for his relatives, but, on the contrary, advises him to accept the bitter reality that they form part of himself and that it is his duty to re-integrate them into himself by “reciprocal identification.” If this marvelous re-integration takes place, the relatives that we love will no longer be outside but within, where we will always be able to find them, since they will not die like the external relatives who are a mere reflection of the familial Archetype. Of course, next to them will be the others, those for whom we do not profess positive affects; and also many ancestor relatives whom we do not remember but who represent ancient trials, evolutive tests, devolved aspects of the familial Archetype.

- g. “Reciprocal identification” is the method of affective reduction of the Family Test. For example, through the Test we locate determinate affects toward Uncle Albano. These affects create the illusion of Uncle Albano’s individuality and prevent his interior re-integration. In order to reduce them, it is only necessary to identify the exterior relationship that links Uncle Albano with us, that is to say: a “reciprocal identification.”

It is evident that this method is intended to nullify the feedback by mutual capture after reducing the exterior relationships between relatives.

We know, through the Test, the affective relationship toward Uncle Albano; reciprocally, we must now find out what the affective is relationship that Uncle Albano maintains with us. For this, we will have to practice empathy with Uncle Albano, situate ourselves in his shoes *in relation to us*, and experience, as if we were truly Uncle Albano, the feelings that he feels for us. Naturally, this cannot be done without a great effort (and no one said it was easy) but it will have the notable effect of *nullifying* our own exterior relationships with Uncle Albano. Of course, such an empathy, which would be almost impossi-

ble to experience with a stranger to our lineage, is not so difficult between members of the same familial superstructure. If the reciprocal identification is successful, if we have managed to “look toward ourselves from Uncle Albano,” and have identified the sentiments that bind Uncle Albano to us, then we will realize with admiration that when we look again at Uncle Albano *our own affects toward him have been reduced*, if not totally disappeared, and the illusion of separateness *has ceased*. The external relationships have been mutually nullified.

But Uncle Albano continues living in the world. What will we see when looking at his face, now that the mutual exterior (affective) relationships have disappeared? Will we again suffer the capture into Uncle Albano’s cultural structure? Capture will not occur again because there is no difference between the exterior Uncle Albano and the interior Uncle Albano, or, if you will, there is an archetypal identicalness between us and him. After the Family Test, when looking at the face of the re-integrated relatives, as in a mirror, we will recognize in them aspects of ourselves; characteristics ignored until then but which we will undeniably know how to find in ourselves.

- h. Only when the Virya has re-integrated a considerable portion of the familial Archetype can it be said, allegorically, that he has increased the flow of his Pure Blood. The path toward mutation is now open because when diluting the illusion of the “thousand familial faces,” the Karmic chains also cease. The process of the familial Archetype aims toward the future; there, is its entelechy. On the other hand, the inverse path of re-integration, just mentioned, is equivalent to inverting the process and marching toward the Great Hyperborean Ancestor, the one who *knows the secret of the Fall because He has been the protagonist*, who is also called: The Great Deceived One. Sooner or later, the Virya who follows the path of the Pure Blood will have to confront Him. And from that supreme confrontation will arise the Primordial Truth. Then the Virya, like a volcano of emotion, poured out in a cascade of millenary passions, will launch himself in order to remove the chains of Deception, the fetters of Treason, and will restore in himself the extraterrestrial lineage of the Hyperborean Siddhas.

The Hyperborean Wisdom says: “Always remember that your family is a tree and a river at the same time.” That is why it is said that the Great Ancestor is “in the roots of the Pure Blood.” There you should seek him, inversely going up the current of the ancestral river or going down some branches that are also hieratic faces, mirrors of yourself. He is waiting for you, from everlasting, for your arrival means His liberation. But be careful how you present yourself before Him; lest His face terrify you and you foolishly pull back. Remember that He is there because He has fallen and that is why His face shows the ravages of ancient and terrible passions. O Virya! He can only be liberated if you look at Him and hold His gaze! But that gaze will mean your death! O Virya! Nothing will be hidden from you, now that you know the Secret of the Tree and the River: yes; at the sight of Him you will die; but you will resurrect in Him, when, already liberated, *He turns His face toward the Origin!* For behind the back of the Great Ancestor is the Primordial Origin, which, *by a mystery of A-mor*, He was deprived of returning to since the Time of Pain and Suffering began. Dead and reborn: when you resurrect, you resurrect the Great Ancestor, and the Sword that was broken in the Origins is welded; you and the Great Ancestor again become one, as you always were without knowing it, and that is why, when marching toward the Origin, dead and reborn, you are an Initiate of the Pure Blood, a Knight of the Gral, an Immortal Siddha, a Divine Hyperborean, a Warrior of Lúclifer, The Gallant Lord. O Virya, you know a great secret: that of the Tree and the familial River; if you are intrepid and audacious, but also humble and detached, and not afraid to see your own misery, then this great secret will lead you toward the Vril!

In the preceding eight commentaries, we have set forth the Family Test that makes it infallibly possible for the Western Virya to establish “when” he can resort to the sexual techniques of Tantrism “without danger.” We have already stated “when” *one should not do so*: when there are *external relationships* with blood relatives. But someone may ask: what do the affective relationships between relatives have to do with the sexual practices that we will carry out with our partner? Whoever asks this question surely forgets that the exoteric objective of all yoga, and also of tantra, is to “awaken Kundalini” and that Kundalini, as a Logos, has the power to “re-create” the bodies of the Virya. Only the one who, like Wilde Jäger, is

ready for anything and nothing ties him to the work of the Demiurge can aspire to mutation. But, if there are external relationships with relatives, it signifies that the Virya is karmically tied and plays a role in the drama of life, and, what is worse, his body only constitutes a part of the familial Archetype. And no one can immortalize “a part” of the microcosm. When Kundalini awakens, *Her Verb will describe the familial Archetype and set its parts*; if the Virya has his relatives “outside” then Kundalini will only re-create “as far as the consciousness goes” and set that part of the familial Archetype that the Virya believes himself to be. This result is inevitable because Kundalini, as a reflection of the Demiurge’s Logos Aspect, has the “secret mission” of harmonizing the microcosm with the macrocosm, man with the Plan, and *will never alter, by Herself, a Karmic relationship* like that which the external relationships with the relatives entail. The consequences of awakening Kundalini vary considerably, depending on the degree of the lost Virya’s confusion, and range from a “benign” fusion with the Demiurge in the Sahasrara samadhi to the familial Archetype’s annihilation of the physical body “by choice,” which will attempt to evolve through the other relatives. This last possibility will cause surprise because, naturally, one always thinks that he is the “best” or most evolved of the family; *but the familial Archetype may not be of the same opinion*. In any case, Kundalini will always conduct Herself according to Her secret directive to “harmonize” (re-creating the microcosm) and “set” (the re-created) in order to maintain or re-establish the synchronism of the microcosm’s rhythms with the macrocosm’s Plan.

For the Virya, the re-integration of the familial Archetype is indispensable, by the Family Test or by any other procedure, *before* awakening Kundalini. But, one might ask, are we, then, going to realize in ourselves the entelechy of the familial Archetype? No! Because everything that we have said about Kundalini refers to Her being “left to her secret directive” and we have yet to say anything about the manner in which one should proceed with the Igneous Verb *during* tantric practices. The purpose of “awakening Kundalini” is only a tactical action, a means, in order to concretize the strategic objective of the return to the Origin, just as the Hyperborean Wisdom teaches every Virya sadhaka.

We already affirmed “when” one should not practice Tantrism: when there are external relationships with relatives and the Virya is linked to the process of the familial Archetype (and to the processes of the psychoid Archetypes of the super-structures). And we explain why: it is necessary to re-integrate the familial Archetype in order to prevent the Kundalini from re-creating only a part of it. But this is but one aspect of the difficulty: and, if you will, the minor one. The greater problem constitutes the fact that “he who suffers from the illusion of external relationships *will not be able to distinguish Kaly.*” And the perception of Kaly is necessary a priori to the tantric praxis because it constitutes the fundament of the Hyperborean restoration that must be performed in the nature of the microcosm in order to achieve its transmutation.

The Hyperborean Wisdom teaches, on the other hand, that “*Kaly only loves he who is complete and one in himself.*” We will soon see the importance of this affirmation.

There is a third aspect of the difficulty (in order to orient oneself) of suffering exterior relationships, which is the following: the Virya who loves or hates his relatives is prone to “love the woman of flesh with the heart,” i.e., to contribute to the process of the Dame Archetype. This propensity comes fundamentally from Karmic relationships, which determine the *type* of the “destined” partner; from the blood confusion, which has caused the “forgetting” of the Hyperborean woman; and from the “partition” of the familial Archetype, which prevents Kaly “from being distinguished.”

Up to here, we have reviewed, in some depth, “when” Tantrism should not be practiced. Let us now see “when” it is possible to do so, and also, a question that was pending. Why?

Let us suppose that the Virya Mengano has succeeded in re-integrating into himself the familial Archetype, eliminating, by reciprocal identification, the “external relationships,” i.e., the illusory affects that were keeping the relatives “outside.” He has done this but has not yet inversely gone up the current of the Pure Blood in order to reach The Great Ancestor. He knows that he must quickly do so because, upon being “complete,” the familial Archetype will accelerate its evolutive process in order to concretize its entelechy. “Being complete” signifies having loosened the Karmic ties, a situation that the familial Archetype will only permit if it can continue to evolve because, otherwise, it will resort to the Devas of Death in or-

der to get rid of the out-of-control Virya. Mengano knows this risk but has chosen the tantric path of the Left Hand in order to march toward the Origin and that is why he sets out to fulfill, the “Ritual of the Five Defiances.” Mengano is a Western Virya and his way of proceeding is inspired by the Hyperborean Wisdom; that is why, although undoubtedly tantric, his acts are conducted according to a symbology more ancient than that of the Kaula School, but adapted to the circumstances of the West and its relationship with the End of the Kaly Yuga. There is a concept of the Hyperborean Wisdom that we will develop in depth later, but which is worth mentioning now because it justifies this apparent departure from Tantric orthodoxy and also explains the difficulties that the Viryas of the West have in professing Eastern philosophies: it is that of *Geochrony*. Geochrony is the property that the Earth possesses to influence the Historical Time of the peoples who inhabit determinate places. Thus, it turns out that not all human communities are in the same relationship with regard to the Kaly Yuga, but that India, e.g., is “further away” from the End of the Kaly Age than Europe. There is a whole “path of the Kaly Yuga,” which begins at the South Pole and ends at the North Pole, but which slithers around the planet by following certain tectonic lines, and we refer to this path when we say, e.g., “in the fourth century, the Germanic people advance toward the Kaly Yuga,” etc. The important thing now is to keep in mind that the tantra of India and Tibet, the Kaula, and even the Kulamārga have lagged behind in relation to the geochronic rate of the West because the West is closer to the End of the Kaly Yuga than the East. That is why, in the twentieth century, the Thulegesellschaft developed its own tantric yoga, which was internally used in the initiations of the **⚡** Black Order. The concepts that we are offering, and those that we will give in relation to the supposed “ritual” of Mengano, come from that Western yoga of the Thulegesellschaft and from the Hyperborean Wisdom. We have preferred to avoid references to Hindu tantra because we would get lost in clarifications and commentaries, since the Easterners, nowadays, do not see concepts as elementary as this with clarity: if the Kula path, as the tantras declare, is the search for an “absolute gnosis,” we ask ourselves: how can they believe that the Demiurge Brahma, with whom they propose the fusion of samadhi, is going to permit it without a punishment? Westerners, on the other

hand, have long known that the search for knowledge, gnosis, is punished by the Gods, and the former have expressed it in the myth of Prometheus or in the myth of the “Fall of Adam,” of the Alexandrian Gnostics, etc. There is a great confusion in current Tantrism and that is why it appears tinged with devotion and ritualism, which disfigures the luciferic and warrior meaning that it should exhibit in its character as a Hyperborean way of liberation for the Kaly Yuga. We will follow another path: we will cross over a bridge that bypasses part of the confusion because it is based on the purity of the Ancient Wisdom, on the one hand, and on the other hand, on the concrete reality that a Western Virya, Mengano e.g., must face daily.

Ritual of the Five Defiances



he Ritual of the Five Defiances consists in drinking wine, eating meat, fish, and parched grain, and practicing coitus or Maithuna.¹⁰³ In each one of these acts the sadhaka defies the Demiurge; in the first four symbolically and in the last one concretely. Before performing each of the Five Defiances, one must meditate on its symbolism so that the Ritual represents a true *individual act of war*. It is once again worth repeating that this final stage of Tantrism should only be attempted when a prior training of organic control by means of yoga has been carried out and a very strong strengthening of the will has been achieved by the detachment and repugnance that the Gnostic experiences toward the work of the Demiurge. When the Virya is “ready for anything,” and exhibits an unwavering warrior resolve, *he can now* face the Family Test in order to gather together the pieces of his soul that are scattered in the world. If he triumphs in this Test and succeeds in re-integrating the familial Archetype in his interior, he will have, then, arrived at the gates of the Mystery of A-mor. Let us say that it is perfectly possible to avoid the confrontation with this Mystery and seek liberation by another Hyperborean way. But if the Virya possesses *an absolute valor, and feels capable of finding himself again*, perhaps he will dare, like Mengano, to perform the Ritual of the Five Defiances. Because this Ritual has the objective of *transmuting* the body of the sadhaka *after having completed the re-integration started in the Family Test, incorporating, into the microcosm, the symbols of the primordial treason*. The meaning of the Ritual is, then: *to incorporate the symbol that represents each defiance*; that is why the deepest concentration is recommended when performing it and, above all, not to experience sensual desires or pleasures during its execution.

103. The oriental ritual “of the Five Ms” proposes to use the same elements and gives, for them, the following symbolic interpretation: wine (Madya) represents the Air; meat (Mamsa), Fire; fish (Matsya), Water; parched grain (Mudra), Earth; and coitus with the woman (Maithuna), Ether or Quintessence. Naturally, such meanings are exoteric and are of no importance in the Ritual of the Five Defiances that we describe here, although it could in preliminary preparatory stages, especially if the Virya follows, in parallel, an alchemical path.

The wine is the symbol of the Pure Blood, and of the Hyperborean memory of the Origin, “*cast into the world by the primigenial treason of the Siddhas*.” Because of it, LúCIFER, the Khristos of Atlantis, consummates the sacrifice of the infernal descent. But His sacrifice was parodied by Jesus Christ, who gave to wine the significance of “plebeian,” Paśu blood, which must be transmuted “outside” in order to transform it into the “blood of Jesus Christ,” that is: into Jewish blood. The first defiance is, then, to drink the wine; that is: to incorporate the Pure Blood that was spilled in the world, in order to transmute it “within,” in the microcosm, restoring the meaning of the luciferic sacrifice.

Animal flesh alludes to the greatest Mystery that exists, *after* the Mystery of A-mor. However, the Hyperborean Wisdom advises the Virya not to inquire into this Mystery until he has achieved the liberation of transmuting himself into a Siddha, so as not to add more horror to the horror of being enchained to matter. Said mystery can be summarized in this way: just as the Hyperborean Spirits were enchained to the evolution of the Paśu, millions of years ago, very much further back, in periods measured in manvantaras and Kalpas, *other strains* of immortal Spirits were enchained to matter. No one knows from where they were coming, whether they were created by the Incognizable or whether they fell from an unimaginable order; what is certain is that they too are prisoners of The One Demiurge who has enchained them to evolutions infinitely more primitive than those that the Hyperboreans of the Earth must suffer. Just as the Hyperboreans are used “in order to produce culture,” as explained elsewhere, those Spirits are utilized in order “to produce life,” animal and vegetable, although they are often projected into the mineral “kingdom” as well. And just as the Hyperboreans were linked to the evolution of the Paśu so that, from the struggle between Hyperborean Spirit and Paśu Soul, culture might arise, so too were those strains of captive Spirits linked to the entities of the devic evolution, in order to obtain the emergence of a new support for material forms: life. When we say that those Spirits are linked to life, we mean only that: “life,” the “fact of living,” and it should not be believed that the group souls connected with the “higher” evolutions of the vegetable and animal kingdoms are an expression of the captive Spirits; such group souls, as their name indicates, belong to the devic evolution (“elemen-

tals” or Devas) and are in every way similar to the “soul” of the Paśu.

Nowhere else, outside the human ambit, can the dramatic character of life be ascertained as in the animal kingdom: in its insurmountable stupidity, in the determination of its instincts, in the horror of the struggle to survive that leads them to devour each other, in the fatality of their death, etc. Without a doubt, it is in the animal where *the infamy of the Demiurge* is best described. Man, in order to endure that vision of fright that is life in the world, created a cultural veil called “poetry” that, for example: there, where breathes a wretched life that constantly eats and defecates, makes one to see: a “beautiful singing bird.” Poetry masks the horror of life and that is why it is the greatest enemy of gnosis. This affirmation may hurt, but it is rigorously certain because much of the madness with which gnostic ecstasies usually conclude comes from an insufficient preparation for resisting the horrifying visions to which the work of the Demiurge is reduced, when gnosis pulls back the poetic veil and dissipates the illusion of aesthetic beauty (which is a pure cultural creation).

Whoever does not possess a gnostic vision of life will not be able to comprehend the mystery of death. And, attention: whoever does not previously comprehend the mystery of death will not be able to access immortality.

This is the knowledge upon which one must meditate before posing the Defiance of eating animal flesh. The meaning of the Defiance is the following: in the meat is present the Mystery of Life and Death (it is necessary to grasp this) and Concrete Death; by eating the meat, one incorporates the symbol of death into the microcosm and prepares the body for immortality. *Immortality implies the interior resurrection of the animal sacrificed outside. And, when the symbol of death has been neutralized by the mantra of life, the body of the Virya, of corruptible matter, is transmuted into Vajra, incorruptible matter.*

The fish symbolizes the terrestrial race of the Paśu: from its origin in dark and ancient ponds¹⁰⁴ to its end in the entelechy of the Jesus-Christ Hebrew Archetype, the entire history of the Paśu is written in the fish. Eating the fish incorporates into the microcosm a symbol that is an expression of the Manu Arche-

104. In truth, the monad of the Paśu “was a fish” in the Lunar Chain and not on Earth, but on a globe that later split into four in order to form the same number of moons, the present one of which is the last that still remains as a terrestrial satellite.

type and that has the mission of “setting” from within the limits of the familial Archetype. One should meditate and comprehend the meaning of this Defiance in the terms in which it is posed here, since the symbolism of the fish is extremely complex and can give rise to intellectual deviations. We will only note that the first of the ten manifestations of Vishnu is *fish-like (Matsya-Avatara)* and that the Manu of this current manvantara, *Vaivasvata*, has always borne the sign of the fish, both in the Vedas, where he received this name, and in Mesopotamia where he was called *Oannes* or *Dagon*, or during the Roman Empire when he was reincarnated as *Ichthys* (Fish) in the Hebrew Jesus, etc.

The germ of grain represents the *Word of the Demiurge*, the concrete expression of His Verb. In the germ, as in any other *bija*, there is a potency that attempts to unfold at the impulse of the Great Breath; that is why the germ is to be considered as the symbol of the psychoid Archetype *at the beginning of evolution*. If the Germ is situated in a *fertile environment*, the Archetype will complete its process, which begins in germination and ends in the production of new germs or “reproduction.” But all these qualities, which the plant acquires during the process of its growth, were already *in potencia* in the original germ or *bija*. If the germ is kept in a bowl, upon contact with the air or *Vayu tattva*, it does not germinate, but if it is deposited in the earth or *Prithvi tattva* then the various potential qualities germinate and actualize in the evolutive process. This symbol has a special importance for interpreting “the awakening of Kundalini” who, like the germ, is a *bija*, or “Word of the Demiurge,” of a particular potential content. But Kundalini is, in Herself, *a Bija that expresses all other bijas; a Word that contains all words; a Sound that is the synthesis of all sounds, for She represents, in the microcosm, the Akasha tattva* or “first Ether” of the Great Breath. Like the germ of grain, Kundalini needs a “fertile environment” in order *to initiate Her unfolding*.

We have already said that Kundalini “awakens” on Her own when desynchronizations occur between the microcosm and the macrocosm and we explained that its “secret mission” is to re-establish said alterations by harmonizing the totality of the rhythms of the biological process. We can now add that such a behavior is due to the fact that the *Kundalini is sensitive to the cosmic fluence or the Great Breath*. If one imagines the *Akasha tattva* as an ocean of psychic substance and in the middle of it

a bubble, one will have an accurate idea about the Kundalini. In man, above the Muladhara chakra, is the *Akasha* bubble, in which interior “Kundalini sleeps.” This bubble, like the germ exposed to the air, does not “unfold” unless its environment is altered by making it fertile. But the bīja Kundalini is a bubble that floats in the *Akasha* contracting or expanding Herself to the rhythm of the flow of the Breath; only a variation in this flow can cause the Kundalini to awaken and attempt to restore the solidary movement. The *Akasha* possesses the dimensions of *Time and Space* and, therefore, by altering said dimensions it is possible to “awaken Kundalini”: this is the principle that is used in the Hyperborean Strategy. In the Universe exist four states of subtle matter produced by the Great Breath: *Prana*, coming from the Sun; *Manas*, coming from the Manu; *Vijñāna*, coming from the Demiurge Jehovah-Satan; and *Ananda*, coming from The One Demiurge. The working with these matters also enables one to awaken Kundalini if Her flow is altered: this is the principle that is used in the Synarchic Strategy, especially the control of the solar Prana by rhythmic breathing, which the profane schools of yoga teach.

Kundalini is the seed of a plant with many flowers; its germination has the virtue of reproducing the process of the Universe because, when the bubble breaks, the original bīja decomposes into all the Words of creation, thus re-creating, in the microcosm, the order of the macrocosm. But this seed is hidden in the man who also does not know the content of its potency, the entelechy of its Archetypes. This is why, upon learning of the germ, the sadhaka incorporates this symbol into the microcosm, duly consciencialized, and poses the Defiance of determining, by his will, the germination *and the fruits* of the plant. This may not be comprehended because, it will be said, “it is acceptable that by choosing the moment of providing a ‘fertile environment,’ one can determine the germination, but how can the fruits be determined if they are *potentially contained in the germ?*” If such is the doubt, think that a pumpkin that grows within a cubic mold will not be spherical but cubic, because *the form determines the being*.

When Kundalini awakens on Her own or by a “synarchic call,” She re-creates “the form” of the familial Archetype and those are “Her fruits.” In the Defiance that we are considering, Kundalini is forced to awaken (germinate) *within a mold* that determines Her form: that mold is the image of the Great Hy-

perborean Ancestor with whose “form” the microcosm will be re-created.

The fifth Defiance consists in incorporating into the microcosm the symbol of the “Hyperborean woman,” i.e., the image of Lillith and, by means of the Maithuna or sexual act “outside,” marrying her “inside.” The success of this defiance, in which the other four become effective, signifies that one has succeeded in concretizing absolute individuation and immortality. But, as his proposal requires the cooperation of the woman “outside,” it will be necessary to once again clarify that the yogini *cannot be just any woman*, much less a “beloved woman,” or one for whom the slightest affect is experienced. The Kaula tantra, and all the tantras “of the Left Hand,” are based on the worship of Shakti, the feminine or active principle of the Demiurge, who is considered as the “wife” of Shiva. We have already warned that the identification of Parvati with Shakti constitutes an error; we will now explain the nature of this error and how to avoid it.

At the beginning of a cycle, when the Pralaya or Night of Parabrahman concludes, the Demiurge lies still unmanifested, sunken into the cosmic Abyss; there, there is an absolute unity. When the “awakening” of The One, His Manifestation, takes place, an evolutive unfolding occurs that reaches the matter of the whole Universe by the impulse of His Breath; this unfolding, from which the Akasha “emerges,” is the “model,” the “mother,” of all the evolutive processes of the Universe. During the Manifestation, the Demiurge expresses Himself in infinite pairs of opposites that make it almost impossible to notice the previous unity. But it is only an illusion, Maya; the unity has not been split because it lies behind the veil of duality, as know well the Gnostics who manage to reconcile the opposites in the microcosm and transcend toward the single Principle. That is why it is useless to discuss the duality or unity of the Demiurge, both concepts being the expression of different “moments” of His behavior, i.e., different “phases” of His cycles of Manifestation, of His “nights” and “days.” But when it is required to take into account the evolutive aspect of matter and its different organizations, the reference to the opposites and their essential duality is inevitable. Then, for the sake of simplicity, and without forgetting that we are dealing with “a second state” in the nature of the Demiurge, we speak of great opposite principles: yin and yang; good and evil; masculine

and feminine; etc. Religious systems derived from such considerations, like all that is religious, imply a gnostic degradation, an exoteric fall, especially if the opposites have been personified and give rise to a devotion on the part of priests and worshipers. For example, the three pairs of opposite principles that we have mentioned give rise, respectively, to the religions of Taoism, Zoroastrianism, and Hinduism, and in all three, the knowledge appears emotionally tinged by the mythical reduction to which the principles have been subjected and by the devotion that every cult implies. The path of the Gnostic, on the contrary, consists in avoiding devotion and leaping toward the beginnings, establishing a transcendent contact with the unity in which the multiple dualities are resolved. But such a contact is not by way of “fusion with The One” nor by any kind of identification with the Demiurge, but by the comprehension of the interior unity of the microcosm in which the macrocosm is reflected. This comprehension is a pure knowledge, a gnosis, which enables the Virya, after an infinite horror, to overcome the Manifestation and to reconstruct the unity of the Demiurge and thus, in a vision of madness, to verify His folly and intrinsic malignity; however, after the horror, comes about the discovery of the True God, *He whom it is not possible to know from the abyss*. All gnosis ends there, in the certainty of the Incognizable, whom *it is not possible to transcend by knowledge and, for that reason, it is necessary to create it with the power of the Spirit*. The Vril offers this absolute possibility.

Duality is, then, mere appearance; but an extremely consistent appearance as long as one does not access the definitive gnosis that enables one to transcend it. In the confused state of the “lost Virya,” or during the transition to the state of “awakened Virya,” one starts from a differentiated perception of reality and its rational decomposition into pairs of opposites. One thus arrives at the concept that the Manifestation is based on a primitive dualism that, in Hinduism, is personified in the male figure of a God and in the female figure of his “wife” or Shakti. Analogically reduced in this way, the Supreme Principles can be reconciled “in the matrimony” of the Gods, fusing themselves into the original unity or “engendering” other manifestations, also dual. But, in the myths in which the Principles are female and male, one sees the cultural conforming action of the Hyperborean Spirits combined with the rational-emotion-

al mechanics of the animal-man or Paśu. Shiva and Parvati are just that: cultural images produced by the Hyperborean “Blood Memory,” adapted in order to represent the Supreme Principles by the Paśu’s rationality. Shiva is the remembrance of the Gallant Lord, LúCIFer. His wife Parvati can be none other than the extraterrestrial partner of LúCIFer: Lillith.

Tantrism, which is, as has been said, a gnostic system, has exoterically fallen after the interpretation of its secret texts made by the dualists of Buddhism. They, who propose fusion with The One, identify, in the microcosm, *Shiva with the familial Archetype and Parvati with Shakti, i.e., with Kundalini*. In this interpretation, the “awakening of Kundalini,” and its ascent to the Ajna chakra, signifies the “matrimony” of Shiva and Shakti. But, as it is easy to deduce after all that has been exposed about the familial Archetype and Kundalini, this “matrimony” is nothing more than the re-creation of the microcosm in harmony with the macrocosm, and the definitive subjection to the Plan of Evolution, i.e., to the process of the Manu Archetype.

This is not, precisely, the objective of gnosis. In order to avoid nirvana and to concretize the aim of absolute individuation, it is then necessary to re-establish the ancient esoteric meaning of the tantric symbols. Only in this way will it be possible to comprehend the Ritual of the Five Defiances.

For the sadhaka Mengano, the re-creation of the familial Archetype as a model of the microcosm, by the Kundalini, constitutes a catastrophe. On the contrary, *he will procure to identify himself with the Great Hyperborean Ancestor, at the culminant moment of the Maithuna, in order to immortalize, with His form, the microcosm*. And this Hyperborean restoration is the declared objective of the fifth Defiance; let us see how one proceeds for its achievement.

We said that Kundalini “sleeps” in a bubble of Akasha, above the Muladhara chakra. That bubble is, in symbolic language, the primordial egg that contains the germ, the seed, of the undifferentiated potential Shakti. Kundalini Shakti is a reflection, in the microcosm, of the first bīja uttered by the Demiurge upon initiating Manifestation and His consequent separation into pairs of opposites. That is why we say that She is the Verb; the plasmating Logos that re-creates the Plan; Bīja of bījas, Word of words. But while She, as a Logos, possesses the principle of all forms, what is Her own form, the prior and first, the ontological and ontic synthesis of all that exists, the

Form of forms? It is necessary to respond to this question *before breaking the egg of Shakti*, because otherwise, just as it happened when opening Pandora's box, countless evils may befall the ignorant man.

Let us make note in passing that the failure or ignorance to answer the previous question is the cause of what we have called "awakening of Kundalini by Her own means," for although this "awakening" is achieved through yoga, if one neglects the formal knowledge of the bīja Kundalini, one will inevitably lose all control over Her plasmating power and will end up succumbing to nirvana. The Gnostic does not seek to annihilate his ego and does not renounce action; on the contrary, *he strengthens his ego by strategically directing the will to act. That is why, in the Gnostic, it is the ego that awakens Kundalini, determining Her form.* We are not speaking of Her essence, which is "feminine" and actively manifests as a Logos, but of the *form* that, as Shakti, the Kundalini will adopt during Her manifestation.

If one ignores the previous question, something that occurs in the exoteric schools of yoga, then Kundalini, upon awakening by her own means, *adopts the form of the primordial mother, whose Archetype "is read" in the genetic memory of the Paśu.* The idea of the feminine principle as "mother" is linked to the separation by sexes of the androgynous animal, the ancestor of the Paśu. Certainly such an idea *has nothing to do with the Hyperborean Wisdom*, since the captive Spirits have no mother and their sexes, as was said elsewhere, are not related to a reproductive function.

To leave Kundalini free to Her own form is to permit Parvati to be identified with Shakti, the "wife" with the "cosmic mother"; it signifies the re-creation, the "rebirth," in the microcosm, of the Manu Archetype, its entelechy, and, consequently: the defeat of the Spirit in its aim of inversely transiting toward the Origin.

There is no shortage of Viryas who, instead of the longed-for liberation from material enchainment, end up even more sunken into matter due to an incorrect and exoteric practice of yoga. And the so-called *devotion or worship* that is demanded toward Shakti has much to do with this result. This emotional attitude is called "strategic disarmament" because the awakening of Kundalini "as the mother" catches the Virya in a state of total helplessness, "adoration," and leads him to succumb to the Manu Archetype's process.

Let us see what the esoteric procedure must be for the fifth tantric Defiance to culminate in the spiritual liberation of the Virya: *it is the Ego that plasmates the first form of the plasmating Logos*. This is achieved by projecting, onto the egg, *the form of Lillith*, who is not a “mother” but the spiritual wife of LúCIFER and the general prototype of the Hyperborean woman.

It should be expressly clarified, in order to dispel any error, that Lillith *is not an Archetype* but a Hyperborean “Blood Memory.”

The problem, in order to comply with such an operation, is the following: how can a lost Virya, who has not yet succeeded in perceiving his Minne, “project” the image of Lillith, whom he has certainly “forgotten” because of the blood confusion? That is precisely why the Maithuna is established, the sexual act with the “woman outside”: *so that, from her, the image of Lillith emerges and is introjected “within,” re-cognized by the Ego, which in turn will project Her on the egg, awakening and plasmating the form of the Hyperborean woman in the Kundalini, thus recovering, “within,” the wife of the Great Ancestor.*

And here comes the terrible demand, the fundamental key to the Mystery of A-mor, without which no tantric practice makes any Hyperborean sense: *the woman outside, the yogini, cannot be just any woman. She must be a Kaly-woman!*

We previously required “not to love the woman of flesh with the heart”; now we know that in addition “to not being loved,” the exterior woman must be a “Kaly.” There are, then, two classes of women: the “Eve-woman” or “woman of flesh” (“Paśu woman”) and the “Kaly-woman.” In order to clearly establish the difference between both types of women, we must start from the following concept: after the fall into matter, by a Mystery of A-mor, the tragedy of incarnation and slavery of the Hyperborean Spirit has ensued; in the drama of life, because of his blood confusion, but, mainly, because of the Mystery of A-mor itself, the Virya *has forgotten the face of his female Hyperborean companion*, whom, generically, we call: “Lillith.” This forgetfulness can only be described as a “*primordial madness*,” and while some ways of liberation enable the Virya to transit the inverse path in solitude, Tantrism, on the contrary, demands *the prior remembrance of the face of the betrothed in order to plasmate, with her form, the egg of Kundalini-Shakti*. The problem consists, then, *in giving a face to Lillith*, a supreme ex-

perience that signifies: *contemplating once again, after millions of years of infamy, the divine face of the Hyperborean woman.*

It must be understood that we are facing a fundamental mystery of the human drama and that it can only be “outlined” literarily, “insinuated” through symbols and clues. Because now we will explain the difference between the Eve-woman and the Kaly-woman, but such an explanation will always be insufficient unless one manages to gnostically pierce the veil of symbols. The problem, “giving a face to Lillith,” can be posed in this way: if the Virya has forgotten, “within,” the face of his betrothed, can he perhaps find it “outside,” by “projecting,” e.g., the “forgotten,” i.e., unconscious face on a woman of flesh? Yes; such a possibility exists, but, we repeat, *the exterior woman, the yogini, cannot be just any woman.* And we add: the Kaly-woman is *she who re-veals, un-covers, the forgotten face for its contemplation, outside.* Why Kaly? Because Lillith, “outside,” is Kaly...

It is necessary that we think this Mystery over. First of all, we must make a distinction: the “projection” of Lillith *is not similar to the projection of an Archetype because it is a Blood Memory.* What is the difference? Every Archetype of the microcosm is reflected in Archetypes of the macrocosm and that is why: *the projection of an unconscious Archetype, from “within,” does not suffer deformation “outside.”* But the Hyperborean Blood Memory has no symbolic equivalences in the macrocosm and so its projection *is not formed but con-formed, composed,* from the “archetypal quanta of energy” (UEVAC) that intervene in reflecting matter. There is, then, a significant deformation when the Blood Memory is seen “outside,” in the world of Maya, the “illusion.” In the case of the Beautiful Face of Lillith, we must assume that the deformation is atrocious given that it, “outside,” has been transformed into the fierce image of Kaly, “The Black One.” Yet the lost Virya has no choice, if he has committed the madness of forgetting The Beautiful Face, but to discover it, to find it again, in the world, transformed *into a terrible deity... and to love her so.*

Kaly is an image of madness because it has been a madness to forget Lillith. The Western sadhaka, in seeking Kaly in the world, is faced with the madness of contemplating Her black face and witnessing Her frenzied dance; that is why the Hyperborean Wisdom advises against posing the fifth Defiance unless one is willing *to love Kaly.* But here by “love,” we mean

something different from the courtly love that we have already previously defined. To love Kaly means *to transmute the Kaly-woman's hatred into a cold fire that will forever freeze the sadhaka's heart*. But how can this affirmation be grasped without knowing the Kaly-woman? We are referring to a great Mystery by means of symbols, insinuating words that perhaps provoke an intuition; but the truth can only be known through struggle and confrontation.

In the West, it will not be easy to find the Kaly-woman if she is sought with a mind loaded with dogmas and prejudices, with a heart sensitive to "Christian" morals, feeling hatred or love toward the family, i.e., experiencing affective relationships. The tantrika is the toughest of the Viryas: "tough among tough," and no one can transit his path if he is softened by Western culture or is sensitive to the illusions of life, that is: if he can still be captured by cultural facts and incorporated into the dramatic process of the psychoid Archetypes. Why so many warnings? Because the Kaly-woman can only be distinguished *by her attitude toward sex* and sex constitutes a "taboo" in "Western culture," i.e., a preeminent cultural premise, which currently conditions the judgment of persons.

If we assume that we have overcome the cultural barriers that would prevent us not only from distinguishing the Kaly-woman, but also from accepting her as an initiator, we will be able to consider her psychological profile, the only form that we have in order to recognize her. In effect: within the confusion that reigns in Western societies, the Kaly-woman must be located starting from her sexual conduct, a requisite that will be difficult to fulfill unless revealing psychological elements are laid out. We will give some of such elements and attempt to describe the psychological profile of the Kaly-woman by alluding to her most salient traits, but, no doubt, these will shock "Christian morality."

First of all, let us say that if the Kaly-woman is indispensable for the Maithuna of the fifth Defiance, *it is not necessary for her to know that she is*. In fact, it is convenient that the woman knows nothing of Tantrism, nor of what is expected of her, in order to avoid her simulation of spiritual states or any predisposition toward the Maithuna outside of the strictly sexual. If one has a Kaly-woman, it is not important *what she thinks: her presence alone ensures the success of the fifth Defiance*. On the other hand, it must be declared from the outset that,

after the Maithuna ritual, if it has fulfilled the objective of awakening the sadhaka, it is advisable not to see the Kaly-woman again.

All these conditions tell us that the Western sadhaka must prepare himself *alone* in order to pose the five Defiances and that the fifth, the Maithuna, must be practiced with a previously chosen Kaly-woman, who will be “unknown,” i.e., of no or almost no dealings. In this way, one preserves the reserved character that, as a “priestess,” the yogini has to exhibit; in the West there are no priestesses initiated in tantra and, therefore, it is necessary to take the Kaly-woman in a hieratic sense that restores the priestly character of her initiating function. Let us now see what the most salient traits of the Kaly-woman are.

In the East, it is affirmed that “the Kaly-woman is a prostitute,” but there, of course, the word “prostitute” alludes to a different meaning than that of “sex for money,” which is given to it in the West. There, is a concept, unknown in the West, of a “sacred prostitute” in order to define a certain class of priestesses who, on determinate dates, officiate the tantric initiation (*Diksha*) of the sadhakas by practicing the Maithuna. But such priestesses, although they copulate with different men in each initiation, do not do it for money, pleasure, or any other motive of material interest; but for the religious objective of “representing the wife of Shiva” during the magical weddings celebrated in the chakras of the sadhaka. What is unknown in the West is that “sacred prostitution” is not simply a practice that can be taught and learned by any woman, but that the Gurus specially select the women who will take the priesthood in order to detect, with exactitude, the Kaly-woman. This subject is so unknown that many people find it difficult to accept the fact that a Kaula Initiate can tell if a woman is fit to be a “sacred prostitute” just by observing her eyes, even if she is a girl. The incomprehension that this subject produces demonstrates the tremendous difference that exists between the Western and Eastern mentality... with esoteric disadvantages for the former.

To “observe her eyes” is not a euphemism, but a literally transcribed truth; for *in the eyes of the Kaly-woman, there is, engraved, a Sign of Death*. Whoever does not know how to “read” this sign, especially the Western sadhaka, must distinguish the Kaly-woman, as we already said, by her sexual conduct. How? Because there is something special in her sexual conduct that the Eve-woman does not possess and which is

perfectly explained by the Eastern concept of the “sacred prostitute.” In effect: the Kaly-woman is a “prostitute,” but this word does not allude to the “flesh trade,” but to *a particular attitude toward the man’s semen* that only they possess and that, in the West, is very characteristic of true prostitutes, those who “make love for money,” as the commonplace goes, but which is by no means exclusive of “public women” but which also occurs very frequently among “honest women,” i.e., those who copulate as much or more than harlots but “do not do it for money.”

Be that as it may, what is important is that the Kaly-woman shows “a particular attitude toward the man’s semen,” which characterizes her, which is innate, i.e., “not acquired by learning”; and which can be anticipated if one knows how to read the “Sign of Death” that is engraved in her eyes. We will synthetically express what such an attitude is, but one will have to reflect much on it because here, concealed, is one of the keys to the Mystery of A-mor: *the Kaly-woman is she who attempts to extract, by any means, the semen from the man*. It is because of this characteristic that the Eastern sadhakas must submit themselves to a rigorous physical and mental preparation in order to control seminal ejaculation during the Maithuna: it is not only a matter of seminal retention and inverting the direction of the orgasm, but of overcoming the whole powerful force of will that the Kaly-woman applies in order to take possession of the semen and exteriorize it in the world.

In order to complete the concept, it is necessary to see, in the “Kaly-woman’s” attitude, a dissociation of pleasure and sexual function. For her, pleasure is not usually the culmination of the sexual act, a kind of reward for well-done gymnastics, but, on the contrary, there is an eternal dissatisfaction in the Kaly-woman that constitutes one of the motives of her prostitution. It is not that the Kaly-woman does not experience the pleasure of orgasm: her dissatisfaction does not have a physiological origin but a psychological one, and we would even dare to say “spiritual,” if we knew that we would not be misunderstood and that “it is known” what class of woman that we are talking about.

From all that we have said about the Kaly-woman, it is in the dissociation of pleasure where the fundamental difference with the Eve-woman should be sought. The latter’s principal objective in sex is the search for pleasure and it will never oc-

cur to her, except circumstantially or because of some perversion, to “provoke” anything in the man, much less to harbor, *at all times*, the intention of extracting his semen. Consequently, the Eve-woman usually “gives herself” to the sexual act in a totally passive manner, expecting to “receive” pleasure. The Kaly-woman, on the contrary, is totally active and lucidly goes through the Maithuna attempting to provoke the masculine orgasm.

These “passive” and “active” attitudes of Eve and Kaly are related to certain ancient myths that the Hebrews expurgated from the Genesis accounts; accounts of Atlantean origin that Moses picked up in Egypt. Before the censorship, Genesis was narrating the story of Adam in Paradise by making mention of two women who were his wives: the first, Lillith, whose magical name completely disappeared from the Bible but is still preserved in numerous Hebrew midrash; and the second, Eve, to whom Genesis attributes a fundamental participation in Adam’s fall, suggestively called “mother of all mortals.” What happened to Lillith, Adam’s first wife? Robert Graves, after investigating hundreds of midrash and documents of the Jewish Tradition together with Rabbi Raphael Patai, has compiled the most important myths in his book, *Hebrew Myths*; there we read the following, as an answer:

“Adam and Lilith never found peace together; for when he wished to lie with her, she took offence at the recumbent posture he demanded. ‘Why must I lie beneath you?’ she asked. ‘I also was made from dust, and am therefore your equal.’ Because Adam tried to compel her obedience by force, Lilith, in a rage, uttered the magic name of God, rose into the air and left him.”

Then, in another myth, it is explained that God created a second wife for Adam, Eve, using a rib or “a tail,”¹⁰⁵ as it is finally written in *Genesis Rabbah*. There can be no doubt that the previous myth, which was once considered a truth as true as the other stories of the Bible, is thousands of years old; and that it must include, like all myths, a transcendent origin, an allusion to some primigenial truth. In this sense, it should not be surprising that Lillith, after Her flight from Paradise, went

105. *Hebrew Myths: the Book of Genesis*, Robert Graves, Raphael Patai, 1983, pp. 66–67. “Some say that God created Eve not from Adam’s rib, but from a tail ending in a sting which had been part of his body. God cut this off, and the stump—now a useless coccyx—is still carried by Adam’s descendants.”

on to become a demonic figure, a “demon of lust,” according to Middle Eastern Traditions, especially Arabic, Jewish, Assyro-Babylonian, and Sumerian; for, as we have already said, “Lilith is Kaly in the world.”

It is not our intention to unravel the previously mentioned myth; we only wish to emphasize that for thousands of years, long before Tantrism existed, *it was already known that the Kaly-woman plays an active role during the sexual act and that she requires, for this, a certain posture.* And that is why the Western sadhaka has no need to study the *Kama Sutra* in order to establish their position during the Maithuna: the woman “below,” in a passive attitude, corresponds to the “Eve” type; and the woman “above,” kneeling, in an active attitude, clearly expresses the “Kaly” type.

The Western sadhaka who decides to pose the fifth Defiance has to be mentally prepared in order to receive Kaly. Not for an instant can he think of obtaining pleasure from the Maithuna and, on the contrary, he will try to envelop himself in an atmosphere of sacred expectation. The Kaly-woman, we have already warned you, may not be pleasant, especially if she has been located in the world of prostitution; but it is inevitable that it so may occur due to the Mystery of A-mor. The Kaly-woman, who is capable of revealing Kaly, also represents the Kaly Yuga; and that is why her unseemliness will be all the more terrible the nearer a society is to the “end of the Kaly Yuga,” i.e., the deeper we go into the spirit of the West. This is the Hyperborean message that is contained in the denomination “Kaly Age,” of which we spoke in another section.

The Kaly-woman demonstrates a special attitude toward the man’s semen that, as we said, is characteristic of the prostitute. We can draw certain conclusions from this affirmation, which will enable us to symbolically approach the “black” Kaly-woman. In the first place, the Kaly-woman, as a prostitute, does not copulate in order to procreate; and in this way she corresponds to the figure of Kaly who, being the exterior reflection of Lillith, represents the Hyperborean Female Spirit, which does not associate sex with a reproductive function. *That is why there is a Sign of Death in the eyes of the Kaly-woman: because her infertile womb constitutes the sepulcher of the human seed. She intends to uproot the seed and deposit it in her womb; but she does not wish it to bear fruit: that is the luciferic attitude of Kaly-women (or Lillim).* She does not desire chil-

dren; if she has them, they are “unwanted” and surely come marked by fatality. Nor does she desire pleasure like the Eve-woman; and if she agrees to Maithuna, she may do so for other motives, such as money, curiosity or intrigue. *Neither does she desire to be loved*, although she usually accepts the wining and dining of her admirers, who, generally, ignore the dangerousness of the Kaly-woman: *“she will mercilessly destroy the imbecile who dares to love her with his heart.”*

On the contrary, the Eve-woman “gives herself” to love and sex with the same unconsciousness, playing a passive and secondary role. In her fertile womb the seed bears fruit and produces children of the flesh. But the most important thing is that the Eve-woman is a “mother”; she represents the Cosmic Mother, the Feminine Archetype of the Shakti emanated by the Mind of the Demiurge, and that is why she expresses the same *setting* character of Kundalini Shakti. When the ordinary man associates his life with that of an Eve-woman, the evolution of his familial Archetype practically ceases; for it remains *set* at the point of development reached up to the moment when the “marriage of the flesh” is celebrated. From there, a refinement process of the cultural structures takes place, which may give the sensation that there is a real progress, but it is only the perception of the unfoldings that the “persona” realizes *from the set level*. The Eve-woman, being a mother, sets her “husband” to a determinate evolutive level of the familial Archetype; but this does not worry anyone because people, out of fear, do not wish to progress too much in the development of the Archetype, preferring instead to keep themselves within the formal limits to which the “glance” of their woman of flesh confines them.

The Kaly-woman manifests a particular predilection for destroying the work of the Eve-woman, whom she despises, using, for this purpose, the power of her Sign of Death. She has at her disposal the means in order to “enchant” the good husband and to take him away from the setting circle of his marriage of the flesh, giving him the possibility to be reborn, i.e., to begin to live another history, now freed from the setting influence of the woman of flesh. But, as soon as she has achieved her objective, the Kaly-woman “breaks the spell” and leaves, as Lillith did with Adam, the lost Virya who, if he is strong, will be able to overcome and take the opportunity to live again; or, if he is faint-hearted, he will crawl back looking for the mater-

nal and setting protection of the Eve-woman. It must be understood here that only those lost Viryas who possess some possibility of “orienting themselves” are seduced by Kaly-women, which constitutes, in a certain way, a privilege; even though a whole bourgeois and pleasurable life may be destroyed. In synthesis: after the Kaly-woman has freed the Virya from the Eve-woman’s spider web, he will be left to his own forces; and then, he who is “eagle-like” will fly and prey; and he who is “worm-like” will crawl and be devoured.

The Mystery of the Kaly-woman is profound, and in many aspects unfathomable; opaque to merely intellectual inquiries. To get to know Her, it is best to confront the living Mystery of Her persona and to seek there, in the blackness of the Abyss, the revelation of the truth; each one, in this way, will gather that part of the Mystery that corresponds to him according to the purity of his blood; and if that personal contact with the Kaly-woman, from among the filth of her prostitution, one sees the horrible figure of the ancient Goddess arise, then yes, practically, it will be demonstrated that the inquiry was not in vain, that it was not a cultural whim but a cry that was springing up from the river of the Pure Blood. After the vision of madness, the Virya will never be the same again; an effect that no literary commentary or intellectual explanation will be able to bring about. That is why it is futile, and to a certain extent sacrilegious, to comment, as we have been doing, on some aspects, however exoteric that they may be, on the Mystery of A-mor. We are persuaded beforehand that the esoteric truth will always remain hidden behind the symbols, in such a way that our intention is simply to approximate the Mystery, so that it, like a gravitational mass, attracts the consciousness of the Virya with an irresistible force. No other has been the criterion with which we have treated the Ritual of the Five Defiances, attempting to induce intuitions that reveal the terrible Mystery of A-mor, the esoteric essence of which lies beyond, far beyond words and symbols. Now it is our turn to complete the description of the fifth Defiance, where the previous commentaries and explanations will be summarized and gain meaning, and it does not seem otiose to add one last warning: *it must be kept in mind that no one can effectively set forth the psychological states of an initiatic experience. The most that one can claim, in this sense, is to show the concrete steps and allude to the fundamental symbols.*

What we will do, then, will be *to teach a formula* for the Western tantric initiation. But this *formula*, which the Virya Mengano will follow step by step, will only be unraveled by the one who has transited the previous path, from the Family Test to the Fifth Defiance, and possesses a heart as hard and cold as Mount Kailas. On the contrary, we discourage anyone who does not meet the required conditions from performing these practices.

In the Warrior's Destiny, there are certain particular moments during which the ancient archetypal symbols come to life and are dramatically inserted into his plot: apprenticeship, trials, baptism by blood or fire, combat, battle, defeat, reward and punishment, death, etc., are all milestones repeated a thousand times in similar circumstances by as many warriors. And in each one of such moments, the warrior experiences a characteristic state of mind, especially related to the concrete symbols of which the structure of the facts is made up. Mengano, who is an expert warrior, has already known the joys of triumph, the patience of the besieger and the desperation of the besieged, the fervor of battle, the pain of losing a comrade, the surprise of betrayal, and the thousand feelings of love. In the warrior, all the states of mind rest on *valor*, without ever breaching it. But the valor required to pose the fifth Defiance is greater than what is necessary for facing any other instance of the Warrior's Destiny, even the hand-to-hand struggle against a ferocious enemy who attempts to take one's life. It should, then, deceive no one if we declare that Mengano's state of mind is one of serene expectation, of an almost religious disposition in the face of the imminence of the Mystery: beneath the serenity of the soul's waters lies the steely depths of an unshakable valor; indispensable, moreover, when one has decided to solve the Mystery of A-mor by way of Tantrism.

Whoever does not know the *expectation of A-mor*¹⁰⁶ will not be able to comprehend the state of mind that the sadhaka must keep when posing the fifth Defiance. In the East, in order to overcome such a difficulty, it is required *to worship the goddess, discovering her in the Shakti*, i.e., in the yogini. But this *sacred admiration* is even less known in the West. That is why it is perhaps worth clarifying that during the "expectation of A-

106. A poetic concept of A-mor can be found in Miguel Serrano's book, *Nos, the Book of Resurrection*.

mor,” one experiences a modest and chaste affect, “like the love for a sister or a bride,” which cannot be tinged even for an instant with the fire of a passion, the origin of which is the desire to physically possess the woman; this latter passion we call “animal,” proper to the nature of the Paśu. In order to comprehend why such a disposition of mind is *necessary*, let us consider the following allegory: the sadhaka’s case is that of one who has lost a precious jewel, a souvenir of his ancestors, the whereabouts of which he has long been unaware; suddenly, one day he discovers that, since then, it had remained sunken into the mire of a fetid swamp; rescuing it does not seem a difficult task, however, it is *necessary* to animically prepare oneself in order to overcome the nausea that will ensue upon entering into contact with the miasma; if one acts with foresight, it will be possible to conquer the apprehension: to do so requires much valor and determination; let us now suppose that one has managed to rescue the jewel: in muddy hands, it does not shine: it is necessary *to wash it with clean water*, purify, baptize, remove the mud, erase the stains, before *enjoying its beauty again; then, only then, will it be recognized as the lost jewel and the joy of the re-encounter will follow*. Analogously, the sadhaka has to predispose himself in order to seek Kaly, the mud-covered jewel, in the swamp of the Kaly-woman... and he will have to count on a lot of valor and determination, and with a modest and chaste affect, in order to overcome his nausea.

It is in the fifth Defiance, more than in any other initiatic path, that the Mystery of Death is most evident. To face Kaly signifies Death or madness, which is another kind of death. But from this Death it is possible to resurrect, to be immediately reborn; because the solving of its Mystery, gnosis, situates the sadhaka beyond its reach, making him immortal. Hence *the need for valor and pudeur*: valor is necessary in order to conquer the pudeur of Death, which is terror. As *Judas* by Lanza del Vasto rightly says when contemplating carrion, “The temptation of you, Death, would devour us all at once, if nature had not erected the wall of pudeur around all voluptuousness. The pudeur of you, Death, is terror; and few are those who force it: your pleasure is therefore an abyss.”¹⁰⁷

107. *Judas*, Lanza del Vasto, 1938; p. 150.

Valor in order to overcome the pudeur of Death, which is Terror; and a chaste expectation in order to conquer the animal passions, are the two essential aspects of the “expectation of A-mor.” But, after the “expectation,” comes the A-mor, which in the allegory is symbolized by “the joy of the re-encounter” upon beholding the lost jewel cleansed of all filth, i.e., Lillith under the terrible veil of Kaly. This A-mor is different from love and we would even say contrary to it: when one possesses A-mor, it is no longer possible to feel love for anything or anyone. Love is always “toward something,” it requires an object of reference and, like all relationships, it depends directly on the cultural structure that determines, in different epochs and places, its characteristic “form”: love is formally determined by morality, i.e., by customs.¹⁰⁸ A-mor, on the contrary, does not register any object of reference because it is a “subject of itself” and it is only possible to experience it when Kaly has been “re-encountered” and the magical wedding has been celebrated by reaching absolute individuation. A-mor is also, like the Gral, a reflection of the Origin: but a reflection *projected on the ego; A-mor is, then, the intuition of the Vril.*

Nothing eternal binds the one who has attained the eternal happiness of A-mor; and that is why, because they lack love for external objects, the Gnostics are feared and inevitably persecuted by the Synarchy. A-mor, as we said, is contrary to love, but not *opposed* to it; nevertheless, this difference is not usually noticed, and A-mor is considered as *opposed* to love, just like that. But the opposite of love is specifically hatred; and hence the identification between A-mor and hatred, which is nothing more than ill-intentioned nonsense. The ⚡ men of the Black Order, e.g., who were receiving the initiation of A-mor and manifesting “a total lack of love for the things of the world,” were called “philosophers of hatred” by the panegyrist of the Synarchy. Naturally, we are of the opinion that if to be valorous and hard, yet beautiful as a God, and to despise the wretched work of the Demiurge, is to sustain a philosophy of hatred: *we declare ourselves partisans of such a philosophy!* Anyhow, we cannot Love what the Paśu loves, and, surely, We Love (A-mor) what it hates.

The sadhaka Mengano, an ancient warrior, has already drunk the wine of the Pure Blood, has eaten the meat, fish, and

108. “Moral” comes from the Latin *mores* = customs.

parched grain, and has meditated deeply on the esoteric meaning of these Defiances. And, as a product of such meditations, he has animically predisposed himself in order to “expect the A-mor.” Next, let us look at the tantric *formula* that Mengano uses when posing the fifth Defiance.

With a Kaly-woman, who is also a true prostitute, he has agreed, for a sum of money, to participate in the Maithuna and has led her, for this purpose, to a suitable environment; i.e., to a place where it is possible to take a bath and lie naked for as long as necessary.¹⁰⁹ There is no affect between Mengano and the Kaly-woman, but the former has not ceased to lavish her with attention and flatter her from the very moment at which they closed the deal, celebrating her “beauty” and showering her with “symbolic” gifts: flowers, perfumes, bracelets, cosmetics, etc.; and also promising future encounters in which his generosity will be even greater. Mengano procures, with such an unusual conduct, to create the sensation of being “inexperienced” or “foolish,” in order to provoke greed, vanity, and contempt in the Kaly-woman, and to definitively avoid the possibility of any positive affect arising in her.

While the Kaly-woman waits naked on the bed, regaling herself with the idea of fleecing the unwary sadhaka, he takes a bath during which he intensifies the “expectation-of-A-mor” state of mind, which we have already defined. Before getting out of the bath, Mengano goes over the “pieces” of the familial Archetype, Zutano, Montano, Bellano, etc., making sure that he is complete in his interior; when he perceives the unmistakable sensation that the flow of his river has multiplied, only then does he enter into the room of the Kaly-woman.

The eyes of the Gnostic pierce the illusions of the world in order to see other realities that lie beyond the cultural veils, i.e., beyond the Strategy of the Great Deceiver. But that gaze brings to the consciousness dramatic images that reveal the Presence of the Demiurge in every atom of matter: it will no longer be possible for the Gnostic to contemplate nature as a “landscape” because the process of the psychoid Archetypes

109. In this “formula,” the Kaly-woman type has been taken “ad extremum” by situating her in the world of prostitution. It must be affirmed that She could be found anywhere else and that, just as it occurs with the “lost Virya” who ignores his Hyperborean ancestors, many women also ignore it. These “lost female Viryas” are unaware that, *in the dark side of their souls, inhabits the Goddess of Death, and that Her terrible power enables them to sacralize the warrior’s love.*

that sustain it unfolds before his keen eye. That is why, upon observing the naked Kaly-woman on the bed, the sadhaka cannot help but think of the swamp that hides the jewel lost in the past under the filthy mud. O blackness of body and soul! In what depths will we find the light of the forgotten Truth? In that prostituted body, behind that degraded will, under that carnal beauty that vanishes, showing the corruption on which it rests, there—see all of you!—is hidden the Goddess of Death. We come to her in order to love her and to overcome the misery of Life. O LúCIFer, give us the strength of your Green Ray in order to resist the vision of the Black Face! Only in this way will we be able to return the apples of Primordial Treason to the world! And only in this way, O LúCIFer, will we be able to find Lillith again and wed her, in order to set out afterward, now transmuted, on the inverse path that will lead us to your army of immortal heroes!

The contemplation of the Kaly-woman, for one who has disposed himself to “await A-mor,” produces a *sacred admiration*, an experience of supreme transcendence; but it is not possible to dwell on it for more than a few moments.

The sadhaka Mengano situates himself beside the Kaly-woman and entertains himself for a few minutes in an erotic game that consists in touching, interiorly repeating certain mantras, her erogenous zones. The purpose of this exercise is not to excite the Kaly-woman, a remote possibility to achieve in a sex professional, but to gain her confidence for the request of the *black kiss*. Before explaining what it is all about, it is worth warning again that the Kaly-woman *will attempt to extract the sadhaka's semen by any means*, which constitutes a danger, during foreplay, which may cause the sadhana¹¹⁰ to fail. That is why a great concentration is required, not only in the seminal retention but also in the “modest and chaste” animic state, which will prevent one from being dominated by animal passions.

The sadhaka Mengano turns over with his back to the Kaly-woman so that she may administer the *black kiss*, about two inches above the anus; and while she does so, he, holding his breath and directing his consciousness toward the egg where Kundalini Shakti sleeps, pronounces the mantra “*Lillith.*” *This is the first call to Lillith.* After the *black kiss*, the Maithuna

110. *Sadhana* = tantric “practice.”

should begin. For this, the sadhaka lies down with the Lingam upward and requests the Kaly-woman to place herself in the “Lillith position,” i.e., kneeling, sitting on his body, *and to stay that way*. In this first part of the Maithuna, the lingam¹¹¹ should remain introduced into the yoni¹¹² *without the bodies moving*, for a fairly long time. The sadhaka’s hands, at least at some point, touch the breasts of the Kaly-woman; but then he places them, with the mudra of the fist, on her navel.

It is at this moment when the fate of the sadhana is at stake and the success of the tantric initiation depends solely on the blood purity of the sadhaka.

Squinting his eyelids, but not enough so as not to see through them, and trying to prevent the Kaly-woman from noticing if she is being observed, Mengano then performs one of the most delicate steps of his “formula”: *he pretends to be a river*. He identifies his consciousness with the liquid current and soon feels himself running, sliding down a channel, converted into a murmuring stream. It should be pointed out that this experience fails *if one only sees the river and does not experience being a river*. On the contrary, *it is necessary for the consciousness to be liquid and to spill inversely down a channel that has an ever-increasing slope*.

First, Mengano was a stream of crystalline water flowing joyfully through a low-banked channel; his “ego” was everywhere, but principally on the surface, placidly contemplating how the grass-covered fields were left behind, alternating, every now and then, with black forests of centennial trees. And suddenly, upon skirting the slope of a polychromatic mountain, between whirlpools of protest and splashes of joy, the confluence of another riverbed came to add more flow to the current of Mengano. In a short time, after several similar confluences, Mengano felt like a mighty river that was arrogantly advancing through a valley of low hills, sharply cut against a clear blue sky. The willows, bent lazily, were pleased to caress, with their branches, the waters, no longer so clear but increasingly violent and roaring. Countless days and nights went by while the Mengano river, already very torrential, was still ascending the ancient riverbeds, overturning in thunderous cascades, tenaciously hitting the rocks on the banks, sometimes

111. *Lingam* = penis.

112. *Yoni* = vagina.

uprooting the weak trees and feeling that the sun was heating up its flow in order to carry away the water, which the refreshing rain was then returning. As the tributary streams were being added, the waters of Mengano were becoming more and more alive; it was no longer only fish, reptiles, crustaceans, hyacinths, ferns, and water lilies: a whole universe of living creatures was inhabiting and being nourished by the river of consciousness! The majority of such beings were unknown *until then* to the astonished gaze of Mengano who, for the first time, was realizing what a *living-object-symbol* is. There are certain organs in the human body that culture assures us are common to all men, and of which we suspect their existence in our body, but which we can never see unless we perform our own dissection; in the same manner, as if we could suddenly become aware of those organs, of which we were possessing only obscure intuitions, so was the discovery that Mengano made of those living symbols, which were as much his own as the organs of his body and which had hitherto remained undifferentiated as the latter. And so, while he was flowing in a torrent through a country of high snow-capped mountains and fearsome blizzards, he was conscious of the overwhelming multiplicity of himself and was weeping brackish tears that were sinking into the depths of his liquid consciousness.

The tributary rivers were becoming increasingly spaced out until they disappeared completely. By then, Mengano had transformed into a very wide and torrential river that was still running roaring between mountains full of snow and lazy glaciers that were discharging their icy floes into the water. Soon the mountain ranges, which were opening on both sides of the Mengano River, were distancing themselves from each other, leaving free the space of a great valley. The width of the river also grew, although its depth diminished, and its waters abruptly diffused into an enormous estuary, the mouth of which was seeming to connect with a sea of immeasurable size. But it was not a sea but another river, of immense flow, which Mengano immediately recognized as the “Villano River,” the Hyperborean current of Pure Blood *that leads “ad-verso flumine”¹¹³ toward the extraterrestrial origin* of his stirp.

When the flowing consciousness that was the Mengano River flowed into the Villano River, it experienced, in an in-

113. Adverse Flumine: upstream, against the current.

stant, that miracle that is called *gnostic expansion*. As if an enormous drop of oil were spreading out over the water in all directions, so was the consciousness of Mengano gnostically expanding. And a new and infinite multiplicity of living-object-symbols was incorporated into his consciousness emerging from the newly discovered waters. The “madness,” thought Mengano, was undoubtedly consisting in letting himself be absorbed by the flow of that fabled River; and really, only his previous training, his limitless valor and the state of mind that he was still preserving, of “awaiting A-mor,” were saving him from losing himself in the unconsciousness of those dark and impenetrable waters, but teeming with unmanifested life. For the River of the Hyperborean inheritance was a frightful hotbed of living symbols and of all kinds of objects, either floating or sunken, which were demonstrating their insane opulence: there were, e.g., islands inhabited by dead ancestors, who were hailing, with vehement cries, the inverse passage of the liquid consciousness; and ancient submerged cities; and ships of a thousand different epochs sailing on an uncertain course; and unknown or perhaps non-existent animals; and infinite other marvels that it would be impossible to describe. The gnostic expansion led Mengano to discover a new world; but that world was that of the primordial madness that came about after the Siddhas’ Treason and the Fall of the Spirit; from there on he could not return *without falling back into confusion*, since the “frightful hotbed,” which was being left behind, would cut him off by modifying the course through which he arrived at the Villano River, or by opening other courses that would only be channels without an exit. In fact, Mengano was aware that the estuary and the parallel mountains no longer existed and that, if he turned back, he would only find the deviation of madness.

But so dire a possibility was not worrying Mengano because his decision to follow to the end was unshakable and, moreover, his will was gnostically fortified as the ancestral current was bringing him closer to the origin of the Mystery. Mengano, at that point of the journey, had noted that the mantle of a growing gloom was covering him as he was advancing. Soon he realized that the waters of the Hyperborean River were running through the bottom of a monstrous and deep canyon excavated in the black rock after a fluvial erosion of millions of years, the towering walls of which were preventing the arrival

of light. But the gloom was becoming even greater due to the fact that the canyon was constantly narrowing, until at last it converted into a sharp gorge through which the water was gurglingly running. And then it became totally dark.

The tenebrous depths of the gorge through which he was sliding prevented him from noticing in time that the riverbed was going to end against the side of a colossal mountain, tinged with a marvelous golden color; that is why he could only have a fleeting glimpse of it before being precipitated into its entrails, when the totality of the flow spilled through a terrifying crevice in the form of a yoni. Although the waters, liquid consciousness, were completely filling the capacity of the stone tunnel, Mengano was sensing in some mysterious way a distant bellowing, which at times was similar to a piercing howl and made him think of a badly-wounded beast. He was whorling for quite some time through the interior of the golden mountain; and as the flow was very strong, he was supposing that if he had not yet crossed it, its diameter must be exceptionally large, a quality that was provoking Mengano's admiration. Soon the roar was deafening and it became clear that there was no badly-wounded beast, but that the waters, when falling to even darker and more terrible depths, were producing the bellowing. And the titanic cascade also consumed the liquid consciousness of Mengano; and he, on irremediably falling toward the abyss, was also roaring and bellowing, falling prey to a *Berserker Fury*.

After so atrocious and resounding a fall came a sudden quietude that Mengano was only then able to perceive when he managed to overcome the violence of the leap and the terror of the abyss.

Marveled, he realized that the waters of the Hyperborean River were feeding a lake located inside the golden mountain, in the center of an enormous cavern, the dimensions of which he dared not imagine. A soft twilight, seemingly coming from a phosphorescence of the rocks, was contributing to increase that magical atmosphere of peace and serenity. Had he a human face, Mengano would have smiled, but his joy at having arrived there, after having traveled so long a distance, was also manifesting itself in that soft ripple that was agitating the surface of the lake and that was, in a certain way, an aquatic smile.

Having lost the notion of time, he could have remained there indefinitely, with his consciousness diffused in a soft

pool that was caressing the rocky shores and receiving on its surface the faded reflection of the crepuscular cavern. Yes; he would have remained like that for a long time, like a pond of consciousness, *if a movement in the reflection* had not abruptly attracted his attention. Something had moved on a less illuminated sector of the shore! And Mengano, who had believed to be alone, suddenly found himself heightening his liquid perception in order to capture, with the water mirror of his face, the cause of that movement, a cause that apparently could not be “living,” since life was inconceivable there, in that unknown cavern hidden in the rocky entrails of the golden mountain. But the image of fright that was being reflected in the “Mengano pond” was belying that supposition: it was undoubtedly a “man” who had been leaning against the trunk of the apple tree, next to the shore, and who was now sitting up with difficulty! But when he was completely upright, Mengano realized that that White Giant was not human; and he had the presentiment that he was in front of the Great Hyperborean Ancestor. He was wanting to preserve his pond-like serenity but a senseless terror was stirring in the depths of his liquid soul; and, when the Giant came close enough so as to reflect a clear image, something *like an uncontainable embarrassment* produced concentric circles on the surface, ripples that were revealing Mengano’s inquietude. An infinite shame seized Mengano upon discovering, reflected in the water mirror of his consciousness, the primordial misery of himself. And to such a disturbance was added the horror of finding that the Giant’s face was *turned backward*, as if in a remote time he had turned his head a “semicircle,” afterward remaining welded forever.

However, what impressed Mengano the most was the knowledge that *that water* that was filling the subterranean lake, and which was the source of the Villano River and of the countless rivers that he had gone up in the inverse direction in order to arrive there, *was gushing from a wound situated in the chest of the giant*. Upon learning of that millenary torment, which had left a mark of pain on the face of the Great Ancestor, a last and terrible shudder completely shook the consciousness of Mengano.

Unable to contain himself, Mengano’s voice rose up from the liquid surface:

“Lúcifer, O Lúcifer!”

And like a bitter lament, the Voice of the Great Ancestor asked:

“Who has uttered the name of the Great Chief?” And then he continued, “I have felt the Source of the Pure Blood stirring...”

“I do not know your name...” responded Mengano from the surface of the pond.

“Every name is a catastrophe, a blight in the Demiurge’s hell... Before we were not named because we knew how to Name... But you, Mirror of the Pure Blood, are tarnished by the madness of the world and need words... I was Anir, do you remember? But, am I still? Mirror of the Pure Blood: your madness in asking about me is the reflection of my own madness, of the ancient deviation that multiplied us and submerged us in the dregs of matter... In the beginning we loved, do you remember?... At the beginning, we loved...”

“I have come to seek you, O Anir,” ascended the trembling voice from the Pond of Mengano, “so that you may guide me toward the origin of our immortal Race. Will you be able to do it?”

“I can no longer see the Origin, do you not realize that my face is turned elsewhere...? And besides, I am dying... I have been wounded at the Beginning, during the combat of A-mor, and the inflicted wound will never heal again... Unless She...”

“O Anir, I wish to heal you!” affirmed Mengano. “You will be able to recover your eternity! The Kaly-woman has come with me and is expecting you outside! She will give you back your honor if you grant her the honor of marrying her forever! O Anir, Great Hyperborean Ancestor, Root of my Stirp, never again abandon Kaly!”

The wounded Giant sighed, with a gesture of infinite weariness, while in his eyes was shining the fire of the old unquenched passion, renewed now by the promise that was springing up from the Mengano pond from re-encountering the Kaly-woman.

“Yes,” assured the Great Ancestor with a demented resolve, “you say well, Mirror of the Pure Blood, I am ready to complete my death, and then to die a thousand times more, *just to behold her face again...!* O Mirror: what happened to us? What is this drunkenness of the Abyss with which we have been defeated? We were as Gods... If I had at least kept my trident, the

new fight would be more evenly matched... But wounded and shackled like this, unable to face the Origin because I have no face with which to face, I am condemned to eternal deviation... ! Unless She... But I must not keep my Betrothed waiting!

Then, advancing with a faltering step, stumbling over the chains that were holding down his ankles, bleeding profusely from the ancient wound, *without seeing where he was going*, for his face was "turned backward," the Great Ancestor wanted to walk in the direction of the pond. But, although a very short distance was separating him from the subterranean lake, it was no easy task to reach it, for a centuries-old numbness had stiffened his limbs; nevertheless, he immediately rolled on the rocky ground, slid down the slope of the shore and finally sank silently into the living waters of the Mengano pond. And Mengano, at that moment, had the sensation of being at the center of an expanding explosion of fire, encompassing not only the Rivers of Pure Blood, but also the totality of the microcosm.

Never did the sadhaka Mengano believe, before that Maithuna, that he would come to know a passion as terrible and voracious as His, which was nevertheless constituting the only motivation *toward the exterior world* on the part of the Great Ancestor. But such a gnosis was necessary, as we will see, in order *to complete the formula* of the fifth Defiance.

When the Great Ancestor submerged Himself in the mirror of the Mengano pond, there was no longer an object to reflect or a reflected image, all difference was consumed in the explosion of fire, and the consciousness of the Virya Mengano and Anir were again one and the same. *The totality of the blood was then "pure," gnostically transmuted, but it was also "fire," because of the Mystery of A-mor.* The next step of the formula was fulfilled at that moment of the igneous expansion and transmutation of the blood.

Since the Maithuna began, and Mengano pretended to be a river, until the instant of the igneous expansion and the Return of the Great Ancestor, only a few minutes had passed, perhaps ten or fifteen; but during that time, the Kaly-woman remained motionless, in the position of Lillith, for it was so agreed upon beforehand. However, after the Return of Anir, without being clairvoyant, anyone would have noticed that the sadhaka's countenance was glowing in an expression of lu-

ciferic happiness; while a more thorough inspection would have observed the soft greenish aura that was now extending around his body. The Kaly-woman could not fail to note the change, and it was perhaps because of that, or because of an unconscious compulsion, that she began to move herself rhythmically with the decision made to *extract the sadhaka's semen*. While her enthusiasm was increasing, Mengano (or Anir) was beholding her harsh face without being noticed, for he had narrowed his eyelids to allow only a weak ray of light to pass through. He did this because he was awaiting the moment at which the dictum of the Hyperborean tantra would be fulfilled: *the Kaly-woman's hatred opens the doors of Eternity*. And on this dictum rested, to a great extent, the success of its *formula*.

According to the Hyperborean Wisdom, the true solution to the Mystery of the Sphinx is found in that dictum.

In order to apply said dictum in the sadhana, the Hyperborean tantra affirms that, "*during the Maithuna with the Kaly-woman, if the sadhaka manages to retain his semen by preventing her from burying it in her infertile womb, the Kaly-woman's hatred will open the doors of Eternity*." Hatred occurs when it becomes clear to her that she will not succeed in "extracting his semen"; it is at that moment that "*the doors of Eternity are opened*"; that is why one must be attentive, without her noticing it, to the variations of her harsh face; for, as the Hyperborean tantra says, "the doors of eternity are the eyes of the Kaly-woman." It is not fitting to add further commentaries to this Mystery; but it is worth remembering that upon observing the eyes of the Kaly-woman, one is beholding a *Sign of Death*.

The gaze of Mengano, as in a dream, was fixed on the eyes of the Kaly-woman; while the latter, rabidly panting, raising and lowering her body in order to grind his lingam with her yoni. And the eyes of the Kaly-woman, shining with lust, were also fixed on the face of the sadhaka, trying to predict the moment of his orgasm and simulating, with feigned sighs and elaborate gasps, the orgasm itself, trying to deceive the sadhaka about the effects that his virility were supposedly producing in her, in order to induce him, in this way, to complete the coitus. But, as time went on without the Maithuna culminating in the ejaculation of semen, the fury of the movements became tempered; and when, at a given moment, the Kaly-woman had the conviction that his orgasm would never come,

a spark of hatred emerged from the blackness of her soul and electrically broke out on her face. It was only an instant, but it was sufficient for Mengano-Anir's attentive gaze to discover that the Kaly-woman's eyes had transformed into two windows of terrifying blackness.

We must declare that this is the crucial moment of the fifth Defiance: if, in the sadhaka, the Will of the Great Ancestor predominates, then all will be lost: *for he will fall again* and, at that instant of maximum bioelectrical tension, *he will love the Kaly-woman outside, as he loved the Eve-woman before, giving the latter his semen;* but if it is the re-oriented "ego," which seeks the inverse path of return to the Origin, that imposes the Will on the conduct of the sadhaka, immortality will be possible, for the sadhaka will not fear *to peer into Eternity.*

In the sadhaka, Mengano was predominating, even over the devouring passion of Anir, an unbreakable will to return to the Origin. That is why, when the eyes of the Kaly-woman were like black-browed cracks, beyond the Sign of Death, Mengano peered into her Mystery and realized that those Doors of Eternity were leading to a Night blacker than all the nights created by the Gods, to an Emptiness that would never be filled by anything or anyone, to an absolute and incognizable Nothingness that, nevertheless, was the reason and matrix of all Being. And then occurred the miracle forbidden to mortal nature: *Mengano felt A-mor for that Eternal Night, Kaly! O Kaly!*

By an alchemy that only those who have pierced the terrible veil of the Mystery of A-mor can know, the *Kaly-woman's hatred was transmuted into A-mor for Kaly.* What occurred next? The cold. The cold of the Eternal Night extinguished the primordial passion in the sadhaka's blood and left his heart frozen forever.

Feeling his heart frozen from A-mor, Mengano's gaze returned from the depths of the Eternal Night to the socket of his half-closed eyes; and then, upon opening them, he found to his horror that the Eternal Night was also A-moring him and had followed him to his world, *the Sign of Death traversing in the inverse direction.* For there was no longer the Kaly-woman, but a fearsome and vengeful Deity who was immediately demanding death by A-mor.

Kaly was the representation of the Eternal Night and as such, she was black and terrifying; She was naked and Her forms were not beautiful, but opulent and coarse; from Her

neck was hanging a necklace with countless skulls strung like beads: they were the heads of Her lovers, those who had died for the A-mor of Her, killed by Her; for the Goddess is the Supreme Prostitute, the one who shares the A-mor with all Her lovers, but She is also the Jealous Wife, the one who does not accept being betrayed by any of them. And although he knew what She would demand, upon contemplating Her dancing on his belly, Mengano again felt, from his heart of ice, that he was A-moring Her beyond all limits. So, holding his breath, he brought his consciousness to the egg of Kundalini Shakti and, on it, twice projected the mantra “Lillith.” *This is the second call to Lillith.*

The sadhaka Mengano was gazing spellbound with A-mor as Kaly was dancing, around his erect lingam, the dance of immortality, drawing, with Her feet and with the mudras of Her hands, the Runes of Death. When he saw that the Goddess had already danced four times, he knew that upon culminating the fifth, She would die. And notwithstanding this certainty, he calmly awaited the fifth round. And only when Her sword was raised threateningly, held by an iron and black arm that was frantically changing its place to the rhythm of the dance, Mengano managed to hold his breath and project on the Kundalini-Shakti egg, three times, the mantra “Lillith.” *This is the third call to Lillith.* And it is the final step of the *formula.*

On naming the mantra for the third time, *the egg broke!* And from amongst the torn membranes was born to life the plas-mating Logos, plasmating in turn with the Hyperborean form of the Divine Lillith. But so perfect was her Beauty, so blinding the light of her blue gaze, so intoxicating the perfume of her silken hair, so sweet the sound of her laughter, so soft her velvet skin, so irresistible the desire for the A-mor of Her Absolute feminine presence, that *to see her and to wed her is a single act.* Thus, upon the breaking of the egg, the interior orgasm is instantaneously produced, with the semen shooting inward in order to fertilize the Bride, who alone will give birth to the “Son of Death.” In effect: Lillith has been wedded by the Great Ancestor and it is He whom She will immortalize by re-creating the microcosm with the power of Her Verb, as was already explained earlier; but in re-creating it, She *causes Him to be born again* and He is, therefore, Her son, a Son of Death.

We are separately presenting aspects of a single act; for at the very moment of the orgasm, while Lillith is wedded “within,” a violent two-handed blow was severing the head of the sadhaka Mengano; but that head was also that of the Great Ancestor Anir, the one who could not look toward the Origin; and that is why the sadhaka Mengano, upon feeling the horrible cracking of the cervical vertebrae when breaking, while sinking into the Black Night of Death, was thinking that losing that deviant head was constituting, without any doubt, a liberation. And so it was that an instant after wedding Lillith, Her Bridegroom was dying, decapitated, who would resurrect after another instant as the Son of Death. And She, who was already born wedded, almost immediately became a Widow.

Here are the paradoxes that are present *in all paths of liberation: the immortal Siddha is the son of Himself, and also the Son of the Widow and the Son of Death.*

But only the *Kulatanrika*, who has offered his head on the altar of Kaly, is called *Caput Niger, Black Head.*

Let us return to the fifth Defiance. After decapitating the sadhaka, Kaly threaded his head on the necklace and then, always dancing, *penetrated into the newly resurrected body of the sadhaka.* She did so through his side, entering and closing it behind her, in that ancient wound that, as some lie, Jesus Christ also had.

We repeat again that the murder of the sadhaka by Kaly and the birth and wedding to Lillith occur simultaneously, because such events are different aspects of one and the same act: the consummation of A-mor. When the sadhaka A-mors Kaly “outside,” he recovers Lillith “inside,” consummating, with Her, magical weddings, the coitus from which the Son of Death will be born; that is why the happiness of possessing Lillith is indescribable, just as is the ecstasy with which the Maithuna culminates, the orgasm of the loveless A-mor in which the semen *shoots inward* and repairs the Original Error.

There should be no doubt about the birth of Lillith from the rupture of the Kundalini-Shakti egg: *Lillith has not been “created” by an act of imagination, nor should She be identified with Kundalini. On the contrary: Kundalini is to Lillith as the human body is to the Hyperborean Spirit: a vehicle of manifestation.* The formula for recovering Lillith has been the following: when beholding the *Eternal Night*, through the eyes of the Kaly-woman, the sadhaka projects his faceless memory of the Hy-

perborean woman; *and the Black Eternity, from the womb of śūnyatā, returns, to the sadhaka, the face of His beloved, which means: it lifts, for Him, the veil of forgetfulness and confronts Him with the Spirit of the Hyperborean woman, who was His wife from the Origins.* But this long-awaited contact *is made through the world, through the intermediary of the Kaly-woman;* and that is why the Spirit of the Hyperborean woman first manifests itself externally, coming from eternity *toward* the world and *from* the world *toward* the sadhaka. It is necessary, then, to give a body to the Spirit, to A-mor her and to wed her. On entering the world from Eternity, the Spirit of Her is Kaly; and because She is Kaly, she already has a face; and by plasmating, with her face, the egg of the Plasmating Logos, she now has a body; but, upon breaking the egg, Kaly “enters” because she is “the Spirit of Her,” who must be born with the Beautiful Face of Lillith; but, before entering, she murders the sadhaka by decapitating his inverted head, for only he who is killed “from without” can be resurrected “from within.”

There is another terrible aspect of this Mystery that we cannot avoid: in order to attain immortality, Lillith must be wed; therefore: Lillith must live! For Lillith to live, it is necessary to grant her a Kundalini-Shakti body, therefore, the egg must be plasmated! In order to plasmate the egg, it is necessary to count on Kaly’s dance; therefore: Kaly must reveal Herself to the sadhaka! For Kaly to reveal herself, the Kaly-woman’s hatred is necessary; therefore: the Kaly-woman will make it possible for Kaly to emerge! For Kaly to emerge, the Kaly-woman will open her eyes to Eternity by inverting her Sign of Death that will no longer be toward the “outside” but toward the “inside”; therefore, the Kaly-woman must die!

In effect: the immortality of the sadhaka implies the death of the Kaly-woman. Initiatic death, symbolic death, or actual death by disincarnation? Who can respond with certainty? Each Western sadhaka, like Mengano, will have to solve this Mystery on his own.

We have expounded in some detail Mengano’s “formula” in order to demonstrate that Tantrism is something more than an erotic game or a series of sexual techniques for “improving conjugal union.” We follow this path because we want to discourage Tantric practices in those Viryas who are not qualified to A-mor Kaly. For this path only offers liberation to those

who, like Mengano, are not afraid to surrender their skull to adorn the necklace of the Goddess.

As an epilogue to this 8th article (on the Ritual of the Five Defiances), we can summarize the foregoing by affirming that Mengano, a Western sadhaka, successfully posed the Ritual of the Five Defiances and achieved his strategic objective of immortalizing the physical body and reaching absolute individuation. Nevertheless, we understand that such an epilogue, even being exact, may be insufficient for the one who questions about Mengano's *subsequent* steps: is it never possible to talk about what occurs *after* the initiation? We are shown a Ritual in which one achieves the awakening of the Kundalini and the immortalization of the physical body. Does this signify that the Vril has been reached? And, ... etc., ... etc.

Naturally, it is not advisable to rationally respond to such questions; and that is why no one who possesses the answers will agree to comment, in this way, on the Mystery of rebirth and immortality. We can, however, approach the Mystery if we resort to the symbolic language with which the former expresses itself. Here, then, is a new epilogue:

Along a sandy shore, flanked by varied foliage, She and He walk hand in hand. At last they stop; in front of them is the water. Pointing with His index finger toward the distant horizon, He says:

"Beyond the water is the mountain and, behind it, the Vril. We have the gnosis; we only need to recover the Power, O Beloved."

And She, smiling sweetly, responds:

"O Beloved: the End and the Beginning are now within our reach; whither shall we go?"

"We must go toward the Beginning," He responded, "which shall be our End."

"O Beloved: shall we be capable of once again abandoning these Delights...? How long we were separated...!"

"We shall be strong! No longer will I love thee on the beach, nor in the water, thou who art soft as a breath; now my heart is frozen with A-mor, and thy face, glowing with whiteness, Loves me from the Eternity of the Night. Hear, Beloved, to the secret that has cost us so much to know: The Great Deceiver has erected a Paradise around the Vril. Many return to Paradise, but few dare to *cross it* and march beyond..."

And they continued to hold hands. Sometimes He was stopping and dancing, and then She was calling Him Shiva. And when She was dancing, He was giving Her sweet glances and calling her Parvati. But at other times, He was unsheathing His sword, radiant with beauty, and She was becoming light and flying like the wind; and then they were LúCIFer and Lillith, marching towards the Origin... And they had many other names that were, like these, residues of ancient rounds of A-mor.

One day they came very close to the place where they had entered in the past, in that timeless time when they were not yet acquainted with the meaning of the word “teardrop.” They recognized with horror the apple forest and heard how its fruits were calling to them, amid laughter and promises. But this time, they did not stop. And upon exiting the enchanted forest, they saw, shuddering with happiness, that the vehicle that one day brought them from Hyperborea was still abandoned in that place. Seen from the exterior, it was seeming carved in marble, with its eight windows and its pointed tower, similar to the helmet of Thai priests. They entered from the back, through one of the windows, and laid their feet on the circular walkway of the interior. Before embracing and covering each other with mutual caresses, they took one last look, through the windows, at the Horror of the Beast. Then they loved each other without reserve, now free from the Madness, and then, for they still had their backs turned, *they prepared themselves to turn their faces toward the inside of the ship, in order to confront the truth.*

Fundamentals of Noological Runics

A.



It has been affirmed, on repeated occasions, the existence of two Kabbalabs and that both deal with the creation of the world by The One Demiurge. One, the Numerical Kabbalah, contains the secret of the ten Sephiroth and the 22 sounds; it enables one to obtain the keys to the psychoid collective Archetypes (Manu) and to know the Plans of the terrestrial Demiurge Sanat Kumara or Jehovah Satan. The other, Acoustic Kabbalah, deals with the way in which these Plans can be put into practice (through the mastery of the soniferous ether, the Akasha tattva) and enables one to elaborate procedures in order to influence the physical world.

Numerical Kabbalah facilitates control over crowds and men *in combination with concrete elements of the Acoustic Kabbalah*. Acoustic Kabbalah enables Thaumaturgy and the exercise of the totality of the occult arts *in combination with symbolic elements of the Numerical Kabbalah*. Both doctrines are, therefore, complementary and necessary for magical praxis.

But as the Numerical Kabbalah is the object, almost exclusively, of study by Jewish sages, and the Acoustic Kabbalah, at least in the last 3000 years, is the domain of the Druids, this complementation has not presented problems to both races engendered by Jehovah Satan, the accomplices and executors of the Plan of the Synarchy. But this was not always so. In the Khristian-Luciferic period of Atlantis, during its Hyperborean splendor, the Numerical Kabbalah, which was a theoretical doctrine for the symbolic interpretation of the world, could be studied by anyone. For millennia it was a collective-cultural patrimony, and so it continued, until the final cataclysm that submerged Atlantis. This is the reason why some surviving ethnic groups, and others who were vassals and were inhabiting continental lands, originally possessed and preserved Kabbalistic knowledge, such as mathematics or astronomy (Egyptians, Sumerians, Maya, etc.).

Contrary to the vulgarization of the Numerical Kabbalah, in Atlantis, the Acoustic Kábala¹¹⁴ was known only to Hyperborean Initiates, while the Luciferic period lasted. Later, when Satanism became a standard practice on the part of the Priestly Caste, a great part of the doctrine was lost and, after the sinking, it practically disappeared as “initiatic knowledge.”

However, a small remnant of survivors who were neither Negroid like the Egyptians, nor Red like the Toltecs, nor Yellow like the Mongols, were possessing sufficient *practical knowledge* of Atlantean Science for reconstructing the Acoustic Kábala, had they wished to do so. This group is what modern anthropology calls “Cro-Magnon men” and who in reality constitute the authentic ancestors of the White Race.

In Atlantis, *there was no significant White Race*. The Cro-Magnon was a minor race of Viryas taken under the protection of the Hyperborean Siddhas of Yellow Race to whom was entrusted, during the Luciferic period (a collective mission linked to the Acoustic Kábala), to be the guardians of the Lithic Wisdom.¹¹⁵ They, better than anyone else ever, possessed the secret of stone: of carving; of its transport by levitation; of telluric resonance, which enabled them to harness the energy currents of the earth; of the construction of rock-crystal transducers, the use of which as an oracle John Dee also knew, and which could constitute, depending on the type, a “ray-launching” weapon, an “ever-burning lamp,” and even a “flying vehicle.” The lithic technology of Atlantis would seem even today, having developed techniques to construct solid-state integrated circuits with 50,000 silicon crystal transistors, oxides, etc., amazing for the precision and effectiveness that it would have achieved.

After the sinking, the White Cro-Magnons, guided by some Hyperborean Siddhas, occupy themselves with “stabilizing the formal relief of the terrestrial surface,” making use of the knowledge acquired in Atlantis. It is these people who con-

114. The noticed difference in spelling marks the clear distinction between the Jewish Kabbalah, which is based on the twenty-two archetypal letters and sounds of The One Demiurge, and the White Atlantean *Kábala*, based on the Runes of Wotan, which were utilized in order to re-sign said Hebrew science.

115. This is the origin of the friendship (Hyperborean camaraderie) between Whites and Mongols; a friendship that today will have to be discovered and actualized: this is the problem that the Siddha Anael faces in Asia, Africa, and Latin America.

struct the great megaliths that are spread along the coasts throughout the world, which are not primitive monuments, but highly advanced technical instruments. But as long as we do not have a clear idea of what the “sinking of Atlantis” *really* means, we will not be able to understand the megalithic labor of the Cro-Magnons. Perhaps something will become clearer if we consider that what occurred *was not a simple cataclysm*, explainable *only* by physical causes such as Plato’s “seismic” hypothesis or that of Velikovsky’s “aerolite,” but the consequence of a terrible war into which the extraterrestrial Siddhas poured all their enormous knowledge. The battlefield was not only the terrestrial surface, for other, more subtle planes of existence were involved in the conflict. In short, much is unknown, but it should be kept in mind that *after* the cataclysm of the Earth, which is a living organism, it had to be *restored* in its physiological functionality so that it would continue to be habitable (so that the “kingdoms” of nature would not react “against” man, for example). In this task, the Cro-Magnons worked using menhirs, dolmens, and cromlechs, and other telluric instruments that will be described later on.

It is now worth quoting a page by Louis Charpentier,¹¹⁶ where he imagines the possible function of the menhirs:

“Some five or six thousand years ago, the Chinese had discovered—and perhaps not only them—that the human body is the seat of currents other than nerve impulses, and that these currents take routes outside all known anatomical channels.

“In a healthy human being, these currents—there are two of them, and they are opposite in nature—balance each other out, but if, for whatever reason, external or internal, these currents become unbalanced, illness sets in, and so does one microbe or another.

“The Chinese physicians of the time had also discovered that it was possible to act on these currents by pricking certain points along their pathways with flint needles—they are now metallic—and thus re-establish the necessary balance or voluntarily create certain disturbances. This is the Chinese therapy known as acupuncture.

“Now, just like the human or animal body, the earth is flowing with currents other than magnetic currents, the nature of

116. *Les Géants et le mystère des origines*, Louis Charpentier, 1969; p. 213

which is relatively unknown, but which cannot remain without an effect on the geological layers through which they pass.

“And they cannot remain without an effect on vegetation.

“I find it impossible not to make the connection between the acupuncturist’s needles and the stone needles of menhirs, large or small, which seem to have such an influence on vegetation.

“Moreover, some eons ago, agronomists attempted—with some success, it seems—to activate crops by erecting antennae capable of collecting atmospheric static electricity, which was then distributed in the soil by various means.

“Although stone is not a good conductor, it is possible that a menhir has a similar effect, particularly when it is damp, for example through dew, the “water of the Moon.”

“We could then imagine that menhirs were erected higher or lower, depending on the intensity of the telluric current, to establish a beneficial balance.

“There would be some very interesting agronomic studies to be undertaken...”

Undoubtedly, we are on the right track here. But, as will be seen in the following commentaries, the terrestrial Acupuncture is only a secondary objective of the megalithic construction.

B.

In order to comprehend what we refer to when we speak of the “lithic technology” that the Cro-Magnons applied, after the Atlantean cataclysms, we should first consider certain aspects of the human habitat on the terrestrial surface. But here we will not deal with the ecological habitat, which the natural sciences are occupied with, but with the *psychic relationships* that man establishes with the *environment* that he inhabits, and the way in which this habitat has been *chosen*. For this, we must define the *psychoregion* concept as “that habitat chosen by man in pursuance of a *psychically appreciable telluric quality*.”

This definition excludes the choice of the habitat out of necessity or obligation. Because in his multiple displacements, man *usually chooses the precise place* where he will construct his dwelling, found a city, elevate his soul to God, etc., motivated by transcendent experiences that surpass the mere physiological necessity to feed or protect himself. Thus, a *psychore-*

gion is the *chosen site*, par excellence, in order to perform acts of greater or lesser transcendence.

In principle, the psychoregion can be “personal” or “social.” We wished to climb a hill; *we chose a certain one*, among many others in the mountain range. Psychological motivations of extreme complexity influenced this choice, but above all we must emphasize the *interaction* between the *chosen hill* and the *fact of choosing*, because this *interaction* precisely converts the preferred hill into a *personal psychoregion*.

Perhaps another person prefers another hill, but, out of a whole landscape of hills, for me, the chosen hill is *different*, it *stands out* in some mysterious way, it acquires an enhancement that transforms it into an *object of appreciation*, into a *personal psychoregion*. Personal psychoregions are, then, as many sites as one chooses for motives of telluric interaction, from a “lovers’ corner,” a fleeting transit, to a “home” in which one is to live for many years.

On the other hand, a social psychoregion is a site that has been chosen on the basis of communal or collective psychological motivations. For example, a place that exerts a certain “charm” on more than one person is a “social psychoregion.” The “cave” chosen, among many others, by a tribe as a communal habitat is also a social psychoregion unless this choice was motivated exclusively out of necessity.

In antiquity, the sites on which cities were erected were chosen for transcendental, religious, or esoteric reasons. Nowadays, humanity inhabits large cities that are also collective psychoregions because, although the current citizens *have not chosen* the psychoregion, their ancestors have done so at some point when, for certain motivations, they decided that this was the preferred place, the exact site, on which the city *should be* erected and the *foundation stone laid*. It is evident, then, that every city has once been a *primordial psychoregion*, chosen by the “founders” and that the same must have occurred with the “sacred places,” on which the religious temples are erected, which were also selected at some primordial time.

In a city with many temples, we choose the one that we like, which constitutes, for us, a *personal psychoregion*. But the place where the temple is located has been, since its foundation, a *social psychoregion*; and it still is, since many faithful who feel the same attraction go to it. As usual, we refer only to telluric interactions and discard other important relationships, but of

a psychological order, such as the “closeness” or “remoteness” of the temple; the worship there of some “saint” or sacred image; any need or obligation; etc.

Without going into more examples, we can complete this concept by considering that nowadays, due to the demographic and material expansion of civilization, it is no longer common to choose a social psychoregion, although all humanity constantly chooses personal psychoregions.

But in antiquity there was a whole science for telluric selection and, in fact, the most ancient cities that have come down to our days have been founded by means of guidelines that are today completely unknown. Modern rationalism, as always, provides dogmatic explanations that “History,” “Archaeology,” etc., rigorously sustain. In order to elaborate such explanations, the Traditions of the peoples, whose wealth of myths and legends (the superstructures’ “cultural objects” of historical facts) could surely come closer to the truth, are never consulted. On the contrary, a “scientific method” is used in order to interpret the fact that, this time, is extremely simple: a rational “manual of procedures” is invented, and by consulting its classificatory guidelines, the labor of the ancients is “academically” graded. In said manual, the guidelines of “defense,” “food,” “water supply,” “communications,” etc., are considered. If, of a city, e.g., Babylon, had been founded “with said guidelines in mind,” that is: near a river, close to trade routes, on an elevation that overlooks the surroundings, etc., then its inhabitants were brilliant, “almost modern.” But if a people committed the “error” of building their cities without following any of such rules of the modern rationalist strategy, if, e.g., they “despised” that impregnable hill and chose to live in the valley, then they are “simply idiots,” primitive beings who “were ignorant of everything” about the way in which “a good city should be planned.”

Of course, the rationalist blindness, which affirmed for centuries that Troy could not be where it really was and which fails to grasp why the Maya constructed cities that they were never inhabiting, does not recognize an important aspect of the problem, which is the choice of psychoregions.

In antiquity, the telluric inspection was entrusted to sensitive persons, priests or initiates, who were never using a rational criterion in this task, but were guided by esoteric knowledge. These persons “knew how to choose the right place” ac-

according to the needs of the community, which were varying in many cases: lasting city, transitory city, encampment, fortress, grange, etc. In very ancient times, a suitable site was carefully selected for every construction, be it a port, a temple, or a bridge. Today, it seems evident that, first, the road has arisen and then, in the vacant places, the bridge was constructed or the stones for jumping over were placed. However, it would be surprising to know how often very great detours were made in order to cross the river at places that were neither the most beached, nor the closest between banks, but the “psychoregion” was predominating over any logical or rational guideline. A river “should not” be crossed anywhere, just as the land “should not” be plowed and cultivated in its totality; there were zones, *negative psychoregions*, where the telluric influence was harmful and which should be carefully avoided. Many of those precautions of the ancients have come down to our days (the ethnologist *Jensen*¹¹⁷ calls them “survivals”) as complements of myths and legends, but they are taken for meaningless superstitions.

The fact is that, in antiquity, the existence of “hostile” places was well known and accepted, which explains many of the “mistakes” that would have been made in the choice of useful places, according to the guidelines of the “procedures manual” of modern rationalists. Because many times, a place endowed with all the *evident* advantages, in terms of security and food, was presenting, instead, the *esoteric* disadvantage of containing a negative psychoregion that was effectively preventing the settlement because it did not guarantee the communal well-being. On the contrary, there were places that were completely unguarded or dangerous, but which were representing true earthly paradises for those who *were enjoying* their psychoregion. Nothing else, e.g., explains the tragedy of Pompeii, built on a slope of the Vesuvius volcano, a city that, despite the earthquake of 63 AD, was rebuilt at the request of its inhabitants, who could not bear the idea of abandoning it and that is why they perished in their totality sixteen years later, in 79 AD, when a new eruption buried it under the fiery lava and ashes.

We will not dwell any longer on a subject of easy comprehension. It only remains for us to add that in Atlantis, during the Luciferic period, there existed a whole “science of psy-

117. Adolf Ellegard Jensen, author of *Myth and Cult Among Primitive Peoples*.

choregions” on the basis of which the Hyperborean Siddhas were instructing the Viryas on the techniques to use in order “to master nature” and to strategically reorient themselves. “Nature,” according to this science, is only a perceptible aspect, a concrete appearance, of that infinite multiplicity of evolutive processes in which consists the macrostructure of a Manu Age. That is why “mastering nature” signifies knowing how to operate on the evolutive processes and achieve the independence of the psychoid Archetypes. The “science” that was enabling such a “mastery of nature” was forming part of the Acoustic Kábala and this, as we already stated, was only known by an elite of Hyperborean Initiates.

After the cataclysms (the “sinking of Atlantis”) the Earth experienced a very great alteration in the functioning of its systems of vital energies and subtle fluids. The contrasts between psychoregions were accentuated to such an extent that the unbalances were easily perceived by man and were often dangerous. In order to equilibrate the psychoregions and make them habitable for humanity, the Cro-Magnons used their knowledge of Acoustic Kábala externally. But for such an exterior action to be effective, it must be accompanied by an *interior work*, for humanity (or its ethnic groups) interacts with the psychosphere (the “subtle” body) of the Earth, the seat of the psychoid Archetypes, and this relationship can “attenuate” or “excite” the contrasts between psychoregions.

Today, the possibility of effectuating a “collective” control over the environment by using psychic powers (the “force of the will”) will be taken with skepticism, since the advance of the Kaly Yuga (the demographic expansion of “confused” rational elements, the generalized predominance of the animal tendencies of the Paśu, etc.) has produced a humanity immersed in a materialistic stupor that prevents it from becoming aware of its mental potential and the power with which this potency could act on the psychoregions. In consequence, modern man finds himself unable to resolve the present-day alterations between psychoregions. The Strategy of the Synarchy has capitalized on this impotence and has launched subversive movements that “denounce the conflict between man and his ecological environment,” but there are, in truth, actual causes that an authentically ecological movement should investigate seriously.

Returning to the psychoregion concept, it is now time to ask: what is the psychological interaction between man and the environment called? We have already defined it indirectly: there are "harmful" places that we call *negative psychoregions* just as there are also places that possess a certain "charm," which we are now going to call *positive psychoregions*. These elementary concepts can be deepened if we define a new concept: that of *psychophysical climate*.

Let us recall that a *psychoregion* is the "habitat chosen by man in pursuance of a psychically appreciable telluric quality." Now, we can add that every psychoregion possesses a *climate* that is particular to it, which can be defined as "the set of sensorial and extrasensorial perceptions that impression a man situated in his environment." The concept of "climate" can be applied to both positive and negative psychoregions, personal or social, etc. For example, from the gloomy "feeling of oppression" that is experienced in a dark cavern to the "electrified atmosphere" of a theater hall that at the climax of the drama or tragedy is perceived by the whole audience, exist an infinity of special "climates" of common knowledge. With the purpose of achieving a clear and comprehensible elaboration of this concept, we will begin by studying the "climates" of the natural psychoregions.

C.

There are places in the world that enjoy a particular charm and sometimes their qualities are so intense that, when perceived by many, they transcend borders and gain a lasting fame. Who has not heard of an inspiring mountain, a dreamy riverbank, a sweetly murmuring stream, all places recommended as very propitious for meditation or love, or for recovering lost health, or even for inquiring into the future? Generally, it is the sensitive spirits, musicians, or poets, who express, in popular language, these geographical qualities by contributing to increase their fame.

Here, we are facing a case of *profound psychology*, the comprehension of which is usually facilitated by establishing analogies with phenomena of Physics. That is why we speak of *psychophysical climate*, although it would be more appropriate to refer to a *microclimate*, i.e., to *the climatic conditions in a limited space*. For example, what do we mean when we say that a psychoregion possesses a particular *microclimate*? We mean

that in that psychoregion is experienced a psychological state different from that which would be experienced elsewhere, even in the immediate vicinity. But such a psychological state does not respond only to sensorial perceptions, i.e., visual, auditory, olfactory, etc., but also involves other planes of being, other regions of the soul, the fiber of which is not easily affected in ordinary life. It is as if the place, its microclimate, *induced* in man a totalizing force that, by dissolving perceptions and sensations, transports him toward the *non-differentiated* or unconscious. And this regression to the primordial states of consciousness, far from constituting a passive attitude on the part of the one who experiences it, generates the *active participation* between man and the microclimate. The *consciousness of experiencing* something special, the ecstasy, is precisely the effect of an *active participation*.

We have already mentioned, on several occasions, the psychosphere concept, which alludes to a “field” that surrounds the Earth and interpenetrates with all the points of its interior space. Such a field is equivalent to what in the Hindu Science of Breath is called the *terrestrial akasha globe*, i.e., that sphere where are deposited the Manu Archetypes, which we have called “psychoid,” and, on a lower plane than these, “akashic records,” which are nothing more than the astral impression of their evolutive unfolding in matter. This field is, also, one of the ten “Vestures” or “Veils” of the Demiurge Jehovah Satan, “The Ancient of Days,” which are named in the Hebrew Kabbalah.

The *universal collective unconscious*, where the psychoid Archetypes lie, takes place in the “field” of the psychosphere, and this interacts with the *personal collective unconscious* of each individual (Paśu or lost Virya). In this way, human evolution is connected with the development of the planetary Archetype, since the psychosphere is the “substratum” of the terrestrial physiology, the “subtle body” that serves as the “vital nervous system” constituted by a complete lattice of telluric energies with millions of vortexes or “chakras” and distribution channels or “nadis,” etc.

In the Fourth Dissertation these concepts will be duly defined and substantiated. The important thing now is to grasp that a certain part of the human psyche, called the “personal unconscious,” *participates in the universal or psychoid collective unconscious*. In fact, the Paśu is absolutely linked to the psy-

chosphere, and only the Virya can transcend the archetypal determination that the psychoid collective unconscious exerts, through the personal collective unconscious, on the ordinary consciousness. That transcendence, that awakening, that liberation that is attained after transiting the path of the return to the Origin, is a subject that we have already dealt with elsewhere.

We are now in a position to define a *psychoid island*, starting from the *psychoregion* concept already studied: *a psychoid island is the counterpart of a psychoregion in the field of the psychosphere.*

These three concepts should not give rise to confusion. In order to avoid misunderstandings, let us note that, inversely, *a psychoregion is the projection of a psychoid island in a determinate geographical area.* From this point of view, it can be affirmed that *a psychoid island is the Archetype of a psychoregion.* It is thus understood that we have first needed to allude to the “psychosphere” concept only for defining the ambit of the existence of “psychoid islands.”

In previous sections we posed the distinction between a “natural fact” and “cultural fact.” Of the latter, we then said that it was “the form” in which a psychoid Archetype was concentrated in evolving toward its entelechy; but as the cultural fact is “essentially structural,” we call the structure that supports said form a “superstructure.” We also studied how the superstructure of the cultural fact “captures” anyone who establishes a cognitive relationship with it, incorporating him as the subject of its drama: with its greatest potency the psychoid Archetype of the cultural fact attempts to unfold itself through the “captured” human subject and by exteriorizing its own cultural structure.

We can apply these concepts in order to explain the origin of that active participation between man and the microclimate that we were just mentioning: *by feeling attracted to a psychoregion, man “actively participates in its microclimate” because he has been captured by the microclimate in which the psychoid island unfolds.* There is not yet a cultural fact per se, *but every cultural fact begins with the “choice” of a psychoregion.* We can say, in order to give more clarity to the matter, that a psychoid island operates as the “framework” or “setting” in which every cultural fact must take place. That is why when a psychoid island captures man in the microclimate of his psychoregion, *by*

that fact alone, the proper framework is arranged for the psychoid Archetypes, in a “Karmic reaction,” to unfold through a superstructure that now includes man and the psychoregion as component elements and the form of which, dramatically, is called: “cultural fact.”

The Archetypes that we call “psychoid islands” evolve concretely in the psychoregions and these are *exclusively geographical* areas; the “microclimate” is the natural structure, *for man*, that supports the psychoregion. Hence, the “microclimate of the psychoregion” is equivalent, in another degree, to the “superstructure of the cultural fact”: both are expressions of the psychoid Archetypes; the former is that of a “psychoid island”; the latter, of a “Manu Archetype.”

An Archetype can be “known,” i.e., made conscious, through the *description* of one of the *concrete forms* that it adopts during its evolution. In this sense, we can affirm that every psychoregion is a *concrete form* that adopts the corresponding psychoid island during its evolution and, therefore, *every psychoregion is a “natural description” of its psychoid island*. One understands then the importance that would have for a Psychosocial Strategy, the possibility of knowing and distinguishing that the psychoregions, as *geographical projections* of psychoid Archetypes, *are graphically representable*. Duly trained sensitive persons, initiated in the Hyperborean Wisdom, can draw on a map the *outline* of the psychoregions or represent, in a “maquette,” their embossed surface. In the **¶¶**, e.g., there was even a corps of officers trained in order to trace the polygonal outline of any psychoregion in Europe.

D.

Let us now resume the distinction between a “natural psychoregion” and a “social psychoregion.”

A natural psychoregion is a place made by the Demiurge’s own hand, i.e., where a “psychoid island” Archetype evolves, like, e.g., a landscape, grotto, chasm, river, mountain, etc., all sites in which a particular microclimate can be perceived.

A social psychoregion is, on the other hand, a place chosen by man to establish his habitat, build settlements, temples, gardens, or palaces, to which he has modified its “natural” character in order to adapt it to communal aims.

It is evident that every site of the second case has been, before the intervention of man, a place of the first case. It is

worth asking: can *any place* be used to, through its formal modification or alteration, provide a microclimate suitable for human needs? No, it is necessary to choose the site carefully. As we saw in the story of Nimrod, The Defeated, it can sometimes take years to locate a suitable site, and that is if one has at his disposal the people qualified in order *to read*, in nature, the descriptions of the psychoid islands.

And yet, in spite of such complexity, the White Cro-Magnons, “wise men of stone,” adapted psychoregions throughout the world so that they could be inhabited by man. After the last Atlantean cataclysm, they “repaired” the terrestrial nervous system, *again* making possible the strategic reorientation of the Viryas. Because, although the megalithic constructions keep a relationship with the currents of telluric energy, this only comes from a *functional aspect* of them and does not constitute (far from it), “the motive” for their making, as Louis Charpentier and other adepts of Druidism suppose. It was not a matter of practicing a “terrestrial acupuncture” but of behaving according to a Hyperborean Strategy: here is the key for interpreting the attitude of the Cro-Magnon constructors.

Today, the Synarchy attempts, by any means, to erase the traces of the Cosmic War, and its tactic, in this sense, consists in denying any warlike determination to the peoples of prehistory. Thus, it will be seen that all the esoteric authors of the Synarchy, Theosophists, Rosicrucians, Masons, Martinists, etc., are *extreme pacifists*, who blindly affirm that “the survivors of Atlantis were founders of civilizations” and provide, “as proof,” the Maya, Sumerian, Egyptian, etc., cultures, without explaining the lapse of millions of years that separate them from that cataclysm.

To get closer to the truth, and to avoid synarchic misinformation, let us ask ourselves for a moment: what is the most likely conduct that the survivors of a civilization that has succumbed and disappeared as a result of a total war would adopt? They would certainly not behave *only* as civilization founders...

In reality, such survivors would maintain a *constant state of alertness* and would only conduct themselves by following *military guidelines*, both for moving and camping and, even if they were trying to save elements of their lost civilization, this would not be, of course, *the main motive that would determine their actions*. We have an example close at hand in those Ja-

panese who survived more than twenty years on the Pacific Islands after the end of the Second War: although they constructed themselves cultural objects necessary for surviving or living, such as a hut, a hook, or a game of go, and although they had transmitted part of their knowledge to the aborigines, “civilizing them,” *none of these motives were determining their actions*; on the contrary, upon being found, it was verified that *at no time* had the soldiers forgotten the war, always maintaining a *constant state of alertness* and conducting themselves, both for moving and camping, according to military guidelines; an example of this was the correct functioning of their weapons, which they had lubricated and kept in good condition, and fundamentally, the *constant respect for the military rank*—a sergeant in 1945 was still a sergeant in 1960—which reveals a whole universe of honor and martial virtues.

This is undoubtedly the attitude of those who survive a total war and *have not surrendered: every movement, every action, is tactical and, therefore, must be executed according to the principles of war. But every tactic, in turn, must be planned in the framework of the General Strategy, so that it contributes to fulfilling its objectives*. That is why the Cro-Magnons moved and acted according to the tactics of the Hyperborean Wisdom and their *acts of war*, be they menhirs, dolmens, or cromlechs, were in accordance with the objectives of the Siddhas’ General Strategy.

The main objective of the Hyperborean Strategy is “the return to the Origin” and, therefore, a dolmen, e.g., has to *mainly* serve for that; and then, for “listening to the music of the spheres” or “locating telluric currents” as Druidism claims. There is, in all this, a great secret that obliges us, in order to not give it away it, to use symbolic language. Let us say, then, that *when the main objective of the Hyperborean Strategy is effectively achieved, the Viryas disappear from History*. We cannot add more.

It thus turns out that every successful action of war carried out by Hyperborean Viryas, *after the total war*, culminates with the *disappearance of its protagonists. But the stone weapons always remain, even if they cannot be used again in the same way as their constructors utilized them*. Louis Charpentier has discovered that, suggestively, the megaliths of France are distributed on an enormous spiral that encompasses the whole country; he has also verified that, since time immemorial,

Worldwide Distribution of Megalithic Constructions

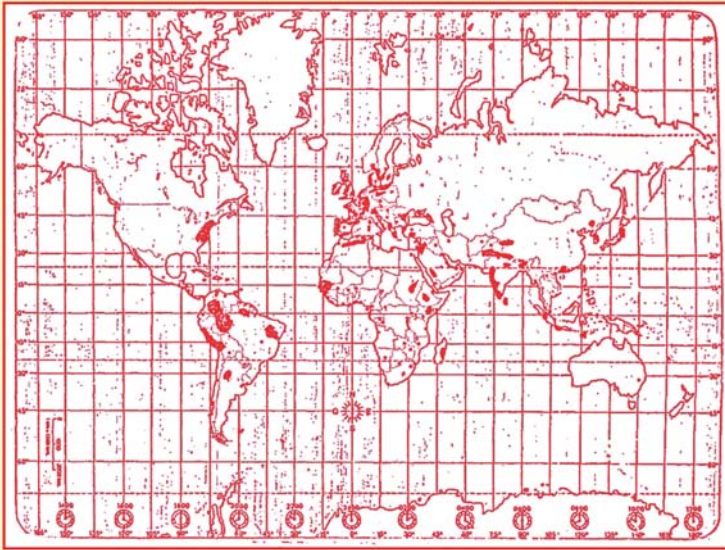

Figure 7

there is a whole esoteric migration of people who, like a gigantic goose game, go on a pilgrimage along the spiral path by seeking a sort of initiation to the mysteries of lithic construction (“masonry”). Naturally, something that Charpentier does not know, such a migration begins *a posteriori* to the stone constructions because *the constructors disappeared when they placed the last stone in the center of the spiral or “eye.”* Those who arrive afterward, and do not know the secret of the stone or lack the blood purity to pose a Hyperborean Strategy, *only have the alternative of purifying themselves by following the stone route of the Siddhas. As the Origin is common to all Hyperborean lineages,* it is possible that by following a path toward the Origin, *opened by other Viryas,* one can *remember the secret* and thus be able to pose a Strategy of one’s own.

To neutralize these lithic weapons and the possibility of “Strategic Orientation” that they offer, the Druids have occupied themselves for centuries with a magical blockade, engraving signs or performing rituals that aim to alter the surrounding psychoregions. But, since they infiltrated the Catholic Church, their actions have been tremendously effective because, after destroying the lithic weapons, on the site where they were located, they erected other stone constructions specially designed according to the principles of the Acoustic

Worldwide Distribution of the Sign of the Origin or
“Swastika Rune.”

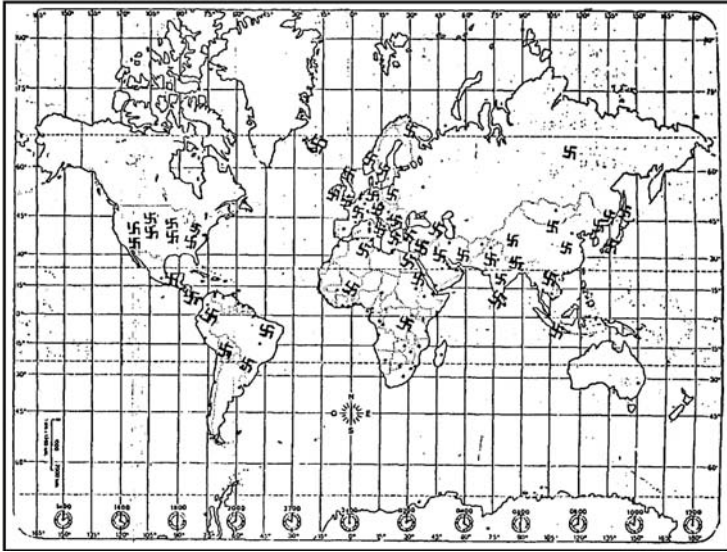

Figure 8

Kabbalah, in order to achieve the strategic goals of the Synarchy. We will return to them later on.

E.

Let us now highlight an element that is closely linked to the transit through the world of the Cro-Magnon Whites. If on a map we indicate the world distribution of the megaliths—which will undoubtedly be incomplete because many have been destroyed—and on another identical map we mark the places wherein the ancient sign of the *Swastika* has been found, we will see that the areas of dispersion are identical.

Although the Swastika is held by peoples who, although inhabiting megalithic places, have not been the constructors of them, this fact does not invalidate the argument; for, precisely, these peoples of inferior culture have picked up or discovered the Swastika from the megalithic construction; *since, in a certain sense, both are one and the same thing*. We have already declared that the megalithic constructions are *tactical weapons* to be used in the framework of a Hyperborean Strategy and that the objective of such a Strategy is “the Return to the Origin.” To comprehend our previous affirmation, we need only recall that in every strategic action *toward the Origin*, the Gral, a re-

flection of the Origin, must intervene. But the Gral is supported by the Rune of Gold and on it is engraved the Sign of the Origin, *from which is derived, through deformations and mutilations, the Swastika rune*. Hence, a lithic construction, designed to move a warrior community “toward the Origin,” makes it possible for another community, more impure or confused, to perceive the Sign of the Origin and “worship,” or consider “sacred,” the Swastika rune.

But the Swastika, which is derived from the Sign of the Origin, does not itself represent a “solar sign” either, despite having been rationalized as such by decadent priests, who also identified it with “life,” “movement,” “reincarnation,” “the pole,” etc. In Antiquity, the Swastika *was a Hyperborean symbol of fire and blood, when both substances are one and the same thing*. Today, fire is *combustion*, the optical illusion of a chemical process of matter’s change of state, and blood, a *plasmatic liquid*. But the Hyperborean Wisdom teaches that *Pure Blood and Fire* possess a common nature, a knowledge that is at the basis of the Acoustic Kábala utilized by the Cro-Magnons for *taming* the currents of telluric energy. He who can *see* telluric energy finds it similar to a fiery vapor; but blood is also *seen* in that same form: as a fiery vapor; and by such an analogy it has been spoken of for millennia as the “blood of the earth” and even, because in watercourses, rivers and streams, the circulation of telluric energy is greater, water has been identified as a “terrestrial blood.”

There is, then, a lost knowledge about the Swastika that only the Aryans of India, the Germanic peoples of Frisia and Saxony, and perhaps the Yucatán Maya, have preserved in a deformed manner until modern times. There is an ancient Sanskrit word for fire that highlights the Hyperborean “memory” of the identicalness that we have been pointing out: it is the word *pū* (पू), which, in addition to meaning “fire,” constitutes the root of *pure*, a quality of the Blood. In effect, in the Vedas one constantly reads that the Blood of kings, warriors, or priests, i.e., of members of the higher castes, is *pure* and, therefore, *fiery*. Blood and Fire were named in ancient Sanskrit, then, with a single word, *pū*, which also was also meaning “to purify,” the undisputed quality of *Agni*, the God of Fire, and of the Blood of the legendary heroes or Siddhas.

The Germans also preserved part of this knowledge by using the Swastika as a *rune*, that is, as a magic word, an element of the Acoustic Kábala.

The Acoustic Kábala is based on the principle that every form is sustained by a Word that is also an Archetype, which was pronounced at the beginning of the Drama by the Creator Logos, that is: the Verb aspect of the Demiurge. Knowing the Acoustic Kábala signifies a *strategic advantage* that enables one, e.g., “to adapt” the environment, the Valplads, so that it serves the aims of a Hyperborean Strategy by diminishing the satanic pressure of Maya, the illusion of the real.

That is why those who were utilizing, as letters, the Swastika, and other symbols of the Acoustic Kábala, were undoubtedly possessing a strategic advantage over other already synarchized peoples. An advantage that today the Germanic people lost because they must submit to the rules of a Judaized, satanist, and synarchic world, but that nevertheless does not represent an evil as great as that which other Hyperborean peoples have had to endure, such as the Aztecs, e.g., who not only lost their alphabet of Kábala symbols, but their culture was destroyed and an attempt was even made to exterminate their race.

F.

We were saying that the Cro-Magnon sowed the world of megaliths and we add as an illustrative datum that the Swastika appears in the same places in which the lithic weapons were erected. We know that an infinity of nonsensical opinions have been voiced on this subject; however, we cannot avoid the statements of certain profane commentators, widely promoted¹¹⁸ as of late, who, after observing that the megalithic constructions are predominantly distributed near the coasts of rivers and seas, draw the conclusion that “the constructors were coming from the sea,” or were, simply, a “seafaring race.” *We immediately refute* this presumption and affirm, instead, that the work of those *leaders* of lithic art was much vaster than what is usually assumed, since it was including *the entire surface* of the continents, and that, because of not knowing, now, what this work consisted of, erroneous and nonsensical conclusions are reached.

118. “Suspiciously” promoted.

The key is in the Acoustic Kábala, which includes the use of *lithic resonators*—menhirs and dolmens—but also *formal devices*—like the cromlech, the labyrinth, the profile of large rocks and mountains, the shaft and the cave, etc., *which work in a descriptive way on the psychoid Archetypes*. Many caves exist that have been artificially modified for serving determinate aims, if not totally artificial; and numerous shafts, throughout the world, show a human elaboration. Also the petroglyphs and cave figures of Cro-Magnon origin, as in the caves of Altamira, Lascaux, or Aurignac, had their fundament in the Acoustic Kábala: certain mantram or magic words were enabling them to operate on the group souls, elementals or egregores, of the animals, those that they wished to hunt or domesticate. In Peru, at the site of Marcahuasi, situated on a small Andean plateau at an altitude of 4,000 meters, an authentic Cro-Magnon workshop-school can be visited today, where anyone can contemplate, “in situ,” a whole arsenal of tactical lithic weapons and verify, if one has the “eyes to see,” that they exceed, in their overwhelming diversity, the better-known menhirs, dolmens, or walls.

G.

We have already referred to the modifications that the Cro-Magnons made to many psychoregions by transforming them from “natural” to “social” or suitable for the Viryas to inhabit and “strategically reorient themselves.” But we also mentioned that in many cases the social psychoregions were once again altered by the Druids, with the purpose of re-adapting them for the Strategy of the Synarchy; for example, it is worth remembering that many of the great temples of “modern” religions, Catholic, Muslim, Buddhist, etc., have been built over ancient “pagan temples,” that is: in places that were venerated since the most remote antiquity and at the center of which existed a menhir, a dolmen, a cromlech, etc. Let us now explain the nature of this *synarchic counter-offensive*.

The Druids infiltrate the Benedictine Order starting from the fourth century and then, from Cister and Cluny, they launch the Knights Templar in the first and most terrible offensive aimed at establishing the World Government of the Synarchy. In studying the A2 Strategy, we will comment on this synarchic plan, and explain the reasons for its failure. What is important is that, for such a plan to work, the religious psy-

choregions of Europe had to be prepared centuries in advance so that their microclimates would capture the “believers” and incorporate them into the process of the Jesus-Christ Archetype.

For this purpose the Druids were counting on the Acoustic Kabbalah, of which they were masters, and on the Numerical Kabbalah, which the Jewish sages gladly placed at their disposal; by combining this formidable knowledge, they developed a technique of psychosocial control based on the archetypal resonance of enormous stone structures. The concrete expression of this work is the Gothic cathedral that “appears,” as everyone knows, in the eleventh century. This gigantic construction is a lithic instrument, finely calibrated in order to generate a religious microclimate, capable of overwhelming the parishioner with its grandiosity and of suggesting to him an attitude of respect and devotion. The Jesus-Christ Archetype needs nothing more than that in order to make the capture, transforming the microclimate into a superstructure and the religious psychoregion into a cultural fact! But the most admirable thing about such an infernal machine, and even if this affirmation scandalizes geneticists, we will say it anyway, is that, once the capture has been made, it “modulates” the genetic information of the believer, making the Jesus-Christ Archetype hereditary, that is to say: genetically Judaizing the unwary; this is achieved because the Jesus-Christ Archetype, which is psychoid, i.e., belonging to the universal collective unconscious, is introduced into and plasmated in the personal collective unconscious by the action of the cathedral, which involves a chromosomal modification *in all the cells of the human anatomical structure*.

Thus, cathedrals are: *machines for psychically (and genetically) programming the population with the purpose of forming a Judaic human type, which act on the genetic inheritance by the transmission of induced symbolic characters.*

The construction of cathedrals, and other monuments that we do not mention for the sake of brevity, is, from the point of view of the Hyperborean Wisdom, an authentic tactic of Psychosocial Strategy put into practice by the White Hierarchy of Chang Shambhala in order to favor the advent of the Universal Synarchy. Regarding the *function* of the cathedrals, both the Druid Fulcanelli and the Celtist Louis Charpentier, and many other authors of similar synarchic affiliation, claim that

they would be “books of stone” destined to perpetuate an “occult knowledge”—here it would be Alchemy—which, due to the “prevailing obscurantism,” cannot be exposed even by initiatic organizations. It is hard to believe that such idiocies can be said in good faith! And we would be tempted to doubt the rational judgment of those who utter them *if we were not aware that there is a Synarchic Strategy and that they are its agents.*

To clarify things, let us recall that with the pyramids of Egypt a similar conspiracy occurs, in which all the “esoteric” authors agree in affirming that, e.g., “Cheops¹¹⁹” is a book of stone, where the Egyptian knowledge has been deposited in order to perpetuate it through time.” On what do they base such a statement? On the perfect geographical orientation of the constructions—pyramids and cathedrals—and on the intervention of very exact and striking numbers, extracted from Physics or Astronomy, in the dimensions of the monument.

Let us now see what the truth is that the Synarchy intends to hide or conceal with absurd theories: pyramids, cathedrals, and, in general, all temples constructed on the basis of kabbalistic principles *are functional machines*, constructed in order to collectively operate on the public. Ask yourself the following question: what machine does not involve measurements and dimensions linked to the laws of nature that it is intended to govern and exploit? To infer from this that the machine is a book into which has been deposited knowledge of nature intended to be read in the future is an unrealistic idea.

A machine is constructed in order to be used in the present and in the immediate future, or so that it functions while it has a useful life, but it is never made thinking about what will occur thousands of years later. It is clear that if said machine passes through millennia and is contemplated by beings who ignore its *functional objective*, it would not be strange that they mistakenly reason that it is “a book” and even “read messages” in it. Think, to give an extremely simple example, of some future men who, ignorant of everything about our civilization, will find *the face of a wall clock, one meter in diameter*. And, from its examination, that it is a “book” made for future generations by some ancient beings who knew the longitude of the terrestrial meridian, were counting to twelve, were probably wor-

119. Also known as the “Pyramid of Khufu” at Giza.

shipping the circle, perhaps the Sun, were in the Bronze Age, etc. All these deductions are logical, but *they indicate nothing about the timepiece*, nor about the *functional purpose* for which it was designed.

It is necessary to understand, then, that cathedrals and other similar monuments must be considered in their *structural totality*, taking into account the *function* for which they were designed. And if we do not know what that function is, *it is better to keep quiet* because otherwise we collaborate with the Synarchic Strategy that consists in fomenting confusion in everything that is related to Chang Shambhala and its demonic plans.

H.

Closely connected to this subject is another synarchic tactic, which we will now warn you about. When speaking of the “Middle Ages” and the “Renaissance,” a deliberate error is usually made in affirming that indeed “a kind of chasm” separates the two epochs. It would seem, according to the historians of the Synarchy, that the Middle Ages were an epoch of impenetrable darkness, the blackness of which was abruptly dispelled by Renaissance humanism. It would thus seem that the Renaissance arises by spontaneous generation, totally divorced from the epoch that it comes to “surpass.” But however well one looks at the thing, again one discovers, behind such opinions, the synarchic tactic.

We will say it again: the Demiurge, His Great Breath, impels matter *to evolve* by following the formal order of His Plans, or Manu Archetypes. The Law of Evolution thus governs all orders of existence, human societies included. But the White Hierarchy of Chang Shambhala usually hastens this social *evolution* by means of an alteration called *revolution*, which is also expressed by a precise law that consists in posing a dialectical opposition to the system that it procures *to revolutionize*. That is why it should not be surprising that after every revolution, the revolutionaries negate and devalue the previous order: it is a pure synarchic tactic, which can be verified by observing the French, Russian, Cuban Revolution, etc., where one evidences the dialectical clash and the negation, on the part of the new order, of any value to the displaced order. This synarchic tactic is very evident and will not require further

commentary... except that the Renaissance does not appear in History as a “revolution.”

However, overlooking the qualifications, we discover at the heart of the Renaissance change, the same synarchic Strategy that directs the great revolutions of History; and with it the negation of the “previous epoch,” which is labeled “regressive.” But, since we dismiss its natural or spontaneous character, we must ask: who launches a revolution as vast as “the Renaissance?” Because every revolution keeps record, behind the evident protagonists, of a hierarchy of “*éminences grises*” who *plan and direct* the movement. The violent aspect is only the culmination of a long subversive work carried out by professionals, “agitators and revolutionaries,” who have also been “agitated” by hidden forces that rarely show themselves to the public eye. We know that the Synarchy lies behind these powerful movements, but in the case of the Renaissance this is not always sufficiently clear and we will say why: because the Renaissance was a *cultural revolution, not a political* one like the violent revolutions that we are accustomed to consider.

The *reaction* to such a revolution was called: *the Cathars and Frederick II Hohenstaufen*; and it was fiercely suppressed. And note that if we speak of a reaction in the thirteenth century to a revolution that takes place in the fifteenth century, it is because we admit that in the thirteenth century the motivations that would trigger the revolution of the Renaissance were already in sight: motivations that the Druids and their henchmen had incubated for eight hundred years. And the greatest of such motivations, the most evident, were the cathedrals, so effective in their cultural revolutionary objective, so splendid in their structural perfection, but, above all, so grandiose in the face of human smallness, that it was very difficult to react against them. But this inhibition was, undoubtedly, another important synarchic objective.

We repeat it for the last time: an error is committed in believing that the Renaissance truly signified a reaction against the culture of the Middle Ages. It was the Middle Ages itself, its *hidden forces*, that generated the Renaissance, preparing itself for centuries, acting on the masses by means of psychosocial tactics, among which, since they are by no means the only ones, are the cathedrals that we have been mentioning.

But, surely, we are tempted to ask: without the cathedrals would there have been a Renaissance? *We believe not.* This an-

swer may give an idea of the importance that we attribute to the collective influence of the gigantic stone machines and to the science that made it possible to design them: the Acoustic Kabbalah.

Whoever has read the previous nine articles will have already understood that we reject “the *socio-cultural* point of view, which recognizes man as the active agent, and earth as passive subject, is now generally accepted”¹²⁰ [by geographers],” because it implies a false concept of “free will” that man, a slave of Jehovah Satan, does not really have. On the contrary, for us, and according to the Hyperborean Wisdom, man is the *subject* of a drama (the process of the psychoid Archetypes) that unfolds in the theater of a psychoregion of Earth, which behaves as an *active agent* that captures and integrates him into the superstructure of cultural facts.

When we made the critique of “historical Ages” and of “culture,” we demonstrated that the Paśu or lost Virya is, in general, a prisoner of cultural facts; but, later on, when defining “psychoregions,” we explained that these constitute the primary ambit in which the process of the historical fact is initiated; the “man” and the “psychoregion” would thus seem to be the fundamental and sufficient elements in order to comprehend the drama of human life. However, this is not so because a “psychoregion,” such as we define it, is a *spatial* concept, which tells us nothing about the *temporal* dimension of the drama. In order to complete this aspect, the Hyperborean Wisdom contributes the complementary concept of *geochrony*, starting from which, *finally*, the Kaly Yuga can be defined.

It is easy to understand that the process of psychoid Archetypes *cannot be the same in different psychoregions*. For example: the Dame Archetype develops through Mr. So-and-so and impels him to seek a “beloved” woman; if the psychoregion where the drama unfolds is, e.g., the “native village” of Mr. So-and-so, then he will be able to project his “impossible love” on one of the village women and sublimate his sexual energy with which the Dame Archetype is fed; but if the psychoregion is, e.g., a “desert island,” the projection will not be concretized “outside” and the process will take another course. In this extremely simple example, but which exemplifies many other cases, it can be noticed that *as the psychoregion varies, so does*

120. *Geography: Its Scope and Spirit*, Jan Otto Marius Broek, 1965; p.27.

the process (because, naturally, the superstructure of the cultural fact varies).

But what is the nature of this variation of the process? For we do not say that the process “will not take place,” but that, simply, “by changing the psychoregion, the process varies.” The answer is: in changing the psychoregion the process varies *temporally*, or, in other words: if a man, captured and integrated into the superstructure of a cultural fact, changes psychoregion, *the process of his drama may become faster or slower, according to the geochronic character of the place.* The importance that the geographical situation of the Viryas has, from the strategic point of view, is now understood.

There is, then, a relationship between every psychoregion and the temporality that the process of the psychoid Archetypes requires *when they unfold in its ambit.* But the different psychoid Archetypes make up an infinite set and, *each one of them, presents a different time of evolution in each particular psychoregion.* That is why it is not possible to take into consideration *any particular Archetype* in order to refer to the temporal relationship between “psychoregions” and “cultural facts” or, in the psychosphere, between a “psychoid island” and a “psychoid Archetype.” The concept of “geochrony” is defined by the Hyperborean Wisdom following an inverse path: *it does not refer to the projection of a psychoid Archetype but to a Blood Memory; to the memory of Lillith outside, that is: to Kaly.* In effect: *“geochrony is the capacity that a psychoregion has for obscuring the image of Kaly.”*

What does this have to do with time? That, *inversely*, a psychoregion where it is not possible to perceive Kaly is a site where *a maximum temporal synchronization can occur* between the biological rhythms of the microcosm and the Time of the macrocosm, which is an expression of the immanent flow of the Demiurge’s Consciousness. Therefore, the geochrony gives a negative indication of the possibilities that a psychoregion offers for achieving *Strategic Orientation* or, in other words: the higher the geochronic index of a psychoregion, the lower the possibility of Strategic Orientation.

Within the Hyperborean Wisdom, there is a science that studies everything related to the psychoregions and their

geochronic relationship with man: it is *Esoteric Chorology*.¹²¹ The Thulegesellschaft was possessing an important “closed circle” specialized in chorological studies, which, after 1936, passed to the Ahnenerbe Institute of the **SS**. And it was the experts in chorology of the Ahnenerbe Institute who carried out a world-wide survey of geochronic indices and discovered that *a true route of darkness could be located, or chorographed, on the terrestrial surface* (Figure 9).

The Secret Route of the Kaly Yuga and the Triangle of the Triple “A.” Buenos Aires – Algiers – Peking

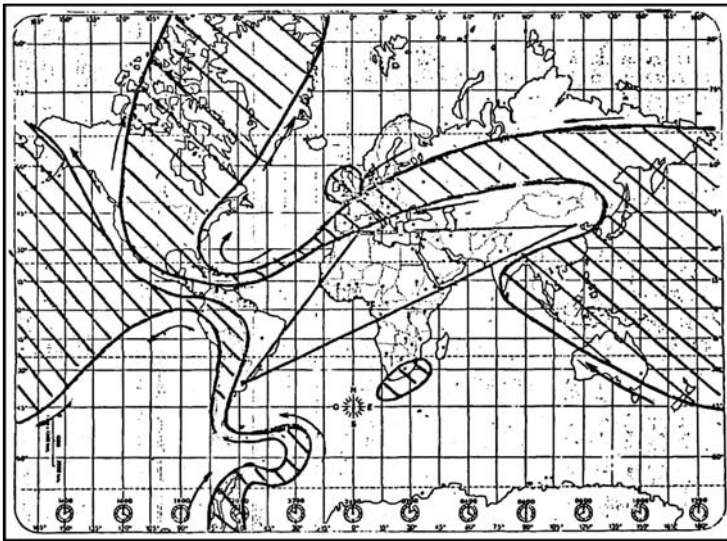

Figure 9

Said “Route” is the current expression of the so-called “Kaly Yuga” and demonstrates, as we stated elsewhere, that its influence is not uniform throughout the Earth, as would be expected from a simple “Historical Age,” but varies in “intensity” according to the latitude considered. The “intensity” that varies

121. Chorology, from the Greek root: *khōros* = *place*, literally means the “study of the relationships between things and persons that give character to places,” in the theory of the *nineteenth-century* German geographer *Ferdinand Freiherr von Richthofen*. But Esoteric Chorology is concerned with studying, not just any places, but “psychoregions” and establishing specifically “geochronic” relationships between them and the man affected by his environment. Esoteric Chorology is, properly speaking, “applied Hyperborean Wisdom.” We can say the same of another complementary science: *chorography*, which studies and develops techniques for representing psychoregions on maps or “maquettes.”

is that of the “darkness” that prevents us from perceiving Kaly and that is why, as we “advance” in the direction of the Kaly-Yuga Route, the loss of Strategic Orientation is greater and greater.¹²²

The Route of the Kaly Yuga has its point of least intensity at the South Pole and that of greatest intensity at the North Pole. From the South Pole it advances over Antarctica by forming with part of the Antarctic Peninsula and several island archipelagos, “the Omega of the Left Hand.”¹²³ These islands, among which are mainly the Orkneys and South Georgia and South Sandwich, are an exterior appendage of the Andes Mountains, which plunge under the Atlantic Ocean in order to reappear in Antarctica as the Antarctandes, at “Tierra de San Martín.” The Route then continues over América, parallel to the Andes Mountains, but, at the equatorial line, it turns sharply westward and “links” the Earth by arising in East Asia and crossing the whole of Europe. Always from east to west, the Route crosses the Atlantic Ocean to Mexico and Cuba, from where it turns around again to the north, encompassing almost the entire territory of the United States, part of Canada, and Greenland.

In this way, following a tectonic schema that is not always clearly noticeable, the Route of the Kaly Yuga imposes a heliocidal or “spring-like” movement around the Earth.

The lines that limit the Route of the Kaly Yuga are called, in Esoteric Chorology, *isochronic curves* because they have been traced “to constant geochronic indices.”¹²⁴ Seven great regions of different “geochronic intensity” are thus distinguished, each one of them limited by isochronic curves (Figure 10). Region I, the “Omega of the Left Hand,” is an enclosure limited by two isochronic curves and two straight lines; the first of these, a a', is a segment of the Antarctic polar circle, and the second, b b', is a segment of the parallel that passes through the Chilean

122. This does not mean that the Kaly Yuga acts *only* on the Route. The whole earth is subject to its influence, but, *for man*, due to the geochronic action of the psychoregions, the *intensity of the darkness* is overwhelmingly greater *within the Route*.

123. It is understood that we refer to the “left hand” of Sanat Kumara or Jehovah Satan.

124. Isochronic, from the Greek roots: *iso* = equal, and *chronos* = Time. It literally means “at a constant time”; but, in chorology, isochronic curves allude to the constancy of the geochronic index.

city of Punta Arenas. From there, Region II extends to the c c' line that forms part of the 90th meridian west. Region III encompasses a very large area that concludes at the d d' line, which is determined by the meridian that passes through Peking. Then follows Region IV, always within the Route, i.e., limited by two isochrons and two straight lines that ends at line e e', which is part of the meridian that passes Mount Elbrus in the Caucasus. Region V, distinctly European, ends at segment f f', part of the meridian that passes through Madeira Island. From there, Region VI extends to the g g' segment, part of the Arctic Circle, and, beyond that lies the end of the Route: Region VII "of maximum darkness."

The Kaly Yuga Motor and
Zones of Intensity Along the Route

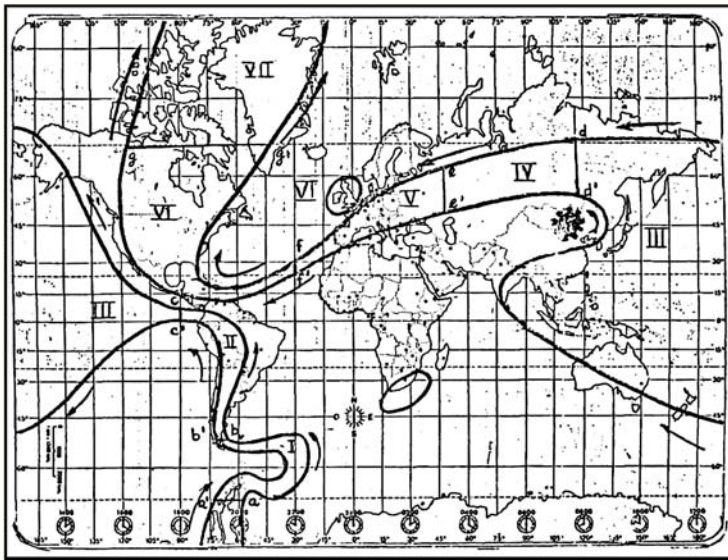

Figure 10

There are also two geochronic zones outside of the Route: one that encompasses South Africa has the dimensions of Region V, and the other, which includes England and Ireland, is a clear indicator of Region VI, "closer" to the end of the Kaly Yuga than the nearby European Region V, that is, where the darkness of the Kaly Yuga is one degree more intense than in Europe.

It has also been indicated, in Figure 10, with a large cog-wheel, the axial center or axis of which is situated in Mongolia, at the "*Kaly Yuga's center of the lowest intensity (of Earth),*" which we mentioned earlier. Strictly speaking, said "center" is the vertex of a colossal vortex of energy that fulfills the function of granting "movement" to the Route and that is why it is called the "Motor of the Kaly Yuga," although it would be more appropriate to say "the glabella of Sanat Kumara." Analogous to the eye of the hurricane, an absolute calm reigns in the "center of lesser intensity" that enables its inhabitants to reach the highest transcendence; that is why the Hyperborean Siddhas have counted, and always count, on those inhabitants, the Mongols, when their Psychosocial Strategy plans require the mobilization of peoples of Hyperborean lineage in different Regions of the Route.

Complementary Concepts



he elementary notions of Esoteric Chorology that we have previously developed will enable us to interpret, from the point of view of the Hyperborean Wisdom, numerous facts that until now, except in the closed circles of the Thulegesellschaft, had been the object of synarchic cultural disinformation. We will give some examples of such an interpretation in the following commentaries:

A.

In synarchic occultism, a nonsensical and tendentious association is usually established between the Swastika, the polar or circular movement of the constellation of Ursa Major, the number seven, the regions of Turan or Mongolia, and the “Hyperboreans.” As a product of this, affirmations such as this one are “proved” or substantiated: “Mongolia is a center of the Swastika’s diffusion; from there it radiated to all the world”; or this other one: “the Swastika symbolizes the helical movement of Ursa around the polar star.” We will waste no time in refuting these and many other similar affirmations; in the light of Hyperborean Wisdom and with the help of Esoteric Chorology, we will go directly to the origin of the confusion.

First of all, we must repeat that the Swastika is an exoteric expression of the Sign of the Origin and, as such, *does not include a “center of diffusion,”* since every Virya, anywhere in the world, sooner or later encounters this Sign when, in his Return-to-the-Origin Strategy, he enters into a charismatic relationship with the Gral. This is what has occurred in historical times with peoples who, inhabiting megalithic areas, have ended up “discovering,” by themselves, and adopting as their coat of arms, the very ancient sign of the Swastika.

We are now going to establish a very important distinction about the origin of the “Hyperboreans” because there are at least three traditions worthy of consideration, but contradictory among themselves. We will mention them in order of antiquity and clarify what class of “Hyperboreans” each one refers to, but first we will say a few words about the term “Hyperborean.”

The usual meaning is that “Hyperborea,” as it appears in Homer and other Greek poets, alludes to a land “beyond” (hy-

per) where the North Wind (Boreas) blows. But this is a late etymology, from the epoch in which nascent Greek rationalism was associating with each “force of nature,” a God or Myth; so it was with the Sun (Helios), the Moon (Selene), Venus, Saturn, the Sea (Poseidon), etc., and, naturally, the Winds: that of the North, Boreas; that of the South, Noto; that of the East, Euro; and that of the West, Zephyr. Before these mythological reductions “boreas” meant “breath of the North,” as in *bóreios* (βόρειος) with a dual meaning of “wind” and “spirit,” as is the case with *pneuma* (πνεῦμα), which has the following meanings: breath, *wind*, exhalation, respiration, life, soul, *spirit*, angel, demon, divine breath, *Holy Spirit*, etc. “Hyperborean” can be translated, then, in an archaic sense, as a “Spirit that comes from *beyond* the North” and Hyperborea becomes “the land (or the origin, provenance) of the Spirits from beyond the North.” This definition, evidently inspired by the Blood Memory, is quite in line with the teachings of the Hyperborean Wisdom, which affirms that the captive Spirits come from Hyperborea, an extraterrestrial, but also “extra-universal” and perhaps anti-material “racial center.” From there the Hyperborean Spirits, whose nature is hostile to the material order of the Demiurge, entered the Universe through a cosmic door known in the Mysteries as the “Gate of Venus.” Why they did so? It is part of the Mystery, but some have supposed that they were coming from losing a cosmic war in other unimaginable universes; however, the most sensible thing is to think that *the warlike conduct of the Hyperborean Spirits is a product of their essential hostility toward the material order.* What is concrete is that although the Hyperboreans have always claimed Hyperborea as their Spirit’s Fatherland and have preserved for it an indelible memory, once fallen into incarnation, because of a Mystery of A-mor, this memory has become sufficiently blurred so that it is only fitting to speak of a “nostalgia for another world.” In the memory contained in the blood Minne, there should be no clear memory of Hyperborea because the latter can only be “seen” by the pure Spirit or Vril; what there is in the Blood is the *memory of the Origin*, i.e., of the Spirit’s place of origin, and this memory responds to a magic word, which it is not advisable to manipulate too much so as not to increase its semantic degradation, which is written: *Thule.*

Thule is the name of the Origin and, therefore, its graphic symbol is the "Symbol of the Origin," from which is derived, by mutilation and deformation, the Swastika rune.

With these clarifications, we can consider the three traditional origins of the "Hyperboreans."

First - The most ancient tradition, the Germano-Nordic, is that which situates Hyperborea in the far north, in an area populated today by Arctic ice. This tradition has no other fundament than the Blood Memory of Thule and its associations to various "motifs" taken from the Akashic records, from the Isle of Valhalla to the Atlantis of Frisia.

However, when the memory is very clear and refers to an island inhabited by giants who were possessing a terrible spiritual power called "Vril" and beautiful women magicians capable of giving a love that was immortalizing the beloved, what is being spoken about is that of the Hyperborean Siddhas and of the Isle of Valhalla that was once really in the North millions of years ago.

Second - Another tradition, much more recent, about ten thousand years before Jesus Christ, has the "Hyperboreans" coming from the West, i.e., from the Occidental West. This is a Greco-Mediterranean Atlantean Tradition that is not only the heritage of the Greeks. These are the ones who best expressed it in historical times, but also of all the remnant peoples or vassals of sunken Atlantis: Ligurians, Basques, Berbers, Egyptians, Cretans, etc. Here, the Cro-Magnon migration, which advanced, as we will see further ahead, inversely following the Route of the Kaly Yuga, that is, from the Atlantic Ocean, through Europe and Asia, toward China and, by sea, to South America, is specifically alluded to. Of course, *not all* Cro-Magnons made it all the way to the end of the Route. The indicated trajectory demanded thousands of years, because the masters of stone were re-adapting the psychoregions, and diverse groups, after remaining for centuries in one place, ended up forming many of the "historical" peoples of White Race. But the migration, its central nucleus, never stopped until it reached the "Omega of the Left Hand"; the proofs of its passage are the traces of miscegenation with "Giants of the White Race" that are observed all along the inverse Route, from Eastern Europe, Russia, China, Japan, the Pacific islands; and South America, from Colombia to Tierra del Fuego.

This second Tradition, then, does not allude to the Hyperborean Siddhas, but to the Cro-Magnons who were, in a spiritual sense, authentic “Hyperboreans.”¹²⁵

Third - The last tradition consists in affirming that the Hyperboreans, primitively, came from the East, without exactly specifying a particular place. Such an attitude varies with the different ethnic groups considered, for while some Germanic peoples were declaring to come from the Caucasus and others from the plains of the Ukraine or the Ural Mountains, the White tradition is usually linked with that of the Yellow by marching eastward, clearly linking itself with the shamans of Siberia and Mongolia. On the other hand, in India, the Indo-Aryans coming from Iran, i.e., from the West, always admitted to a “Nordic” origin; but here we are talking about the North of India, i.e., the Himalayas and, further on, Mongolia. This Tradition also has its basis of truth, like the other two, but in this case the error lies in identifying the whole ethnic community with certain “Gods” or Legendary Heroes, who in truth were coming from East Asia or, more concretely, from Mongolia. Of course, we are not referring to the Masters of Wisdom of Chang Shambhala, so dear to Western theosophy, but to some Hyperborean Siddhas who, by taking advantage of the “Kaly Yuga’s center of lesser intensity,” from there, burst into the History of the peoples in order to carry out a racial Strategy. From there was coming Odin-Wotan and toward there was returning, every nineteen years, the Hyperborean Apollo, who left a cultural trace of that transit to the Orient in the symbols of the bear, the seven, the pole, etc., that many of the peoples “in his path” bore.

It is true, then, that there were “Hyperboreans” coming from the Far East, as the noted third Tradition affirms, but those were Hyperborean Siddhas (who were later incorporated into mythologies as Gods, Angels, or Heroes) and not migratory peoples.

B.

The Cro-Magnons, masters of lithic art, initiate their strategic displacement *from the Atlantic*, following an inverse direction to that of the Kaly-Yuga Route. They begin in Region V

125. However, from the point of view of the current Hyperborean lineages, it is that Cro-Magnon migration that explains the origin of the White Race and its geographical distribution.

(Figure 10), where they apply almost the totality of their megalithic science, and then slowly move toward Regions IV, III, and II. In each Region, three things happen: one group *disappears from History*; another group settles in the psychoregion, especially in order to practice Agriculture and stockbreeding; and a third group, the bulk of the race, moves in the indicated manner toward the southern regions. While this migration takes place, i.e., over thousands of years, the Hyperborean Siddhas *in charge of leading the Cro-Magnon Strategy* establish themselves in the “center of lesser intensity” where they open a gate toward the Isle of Valhalla, called by them, Agartha. Such a gate, a nadi-topological tunnel between dimensions of space, *oriented inward into the Earth*, is the origin of the belief that Agartha, the land of the Siddhas, is a “subterranean world.” It is worth noting here a fact that will later become important, when we reveal the “Incredible Secret of Heinrich Himmler”: *the Hyperborean Siddhas who led the Cro-Magnon Strategy were of Yellow Race*. This particularity was due to the fact that said Siddhas were, hundreds of millions of years ago, those who developed and taught the Acoustic Kabála to the Cro-Magnons, in the Second Atlantis.

C.

Connected with this theme, it is necessary to consider the Führer’s General Strategy since, it can be assured, whoever ignores the existence of the Kaly-Yuga Route will never be able to comprehend the offensive toward the East that Germany undertook during the Second World War. Political or geopolitical explanations have been tried out, the purpose of annihilating the Russian communist regime, the need to conquer “living space” or Lebensraum in the East, but the real strategic objective was known only to very few persons in the Third Reich: the Führer, Rosenberg, Rudolf Hess, Himmler, the **⚡** Initiates and a few other persons; and this objective was as follows: to march with a luciferic army, under the banner of the Swastika, along the Route of the Kaly Yuga *in the inverse direction*, it is said, “down the Kaly Yuga” until South America. However, the success of such an esoteric objective could only be achieved by carrying out a reckless “commando” operation consisting in occupying the center of lesser intensity, in Mongolia, and “operating the door of Agartha.” We will return to this matter in order to explain why that operation failed de-

spite several attempts to accomplish it several times, with greater or lesser desperation.

D.

“Within the Route of the Kaly Yuga are distributed the principal chakras of the Earth.” This affirmation of the Hyperborean Wisdom would not require a commentary except for the possibility that it misleads the declaration that we made elsewhere in the work that “Israel fulfills the function of Earth’s Heart or Anahata chakra.” In effect: by observing Figure 10, it is clearly noticeable that the State of Israel is outside of the Route, which seems to contradict the previous affirmation. But there will be no possibility of error if we clarify that the Israel chakra is constructed by the “Chosen Race” and not by the State of Israel. On the contrary, the concentration of members of the Hebrew race in Palestine *is an act opposed to the plans of the Synarchy*, a matter of which the Führer was perfectly aware and that is why he tried to favor the emigration and settlement in “Eretz Israel” of European Jews. Several negotiations between Germany and England to concretize this migration¹²⁶ were frustrated by the intrigues of English Free-

☆ Hebrew Race: Principal Areas of Distribution (1980)

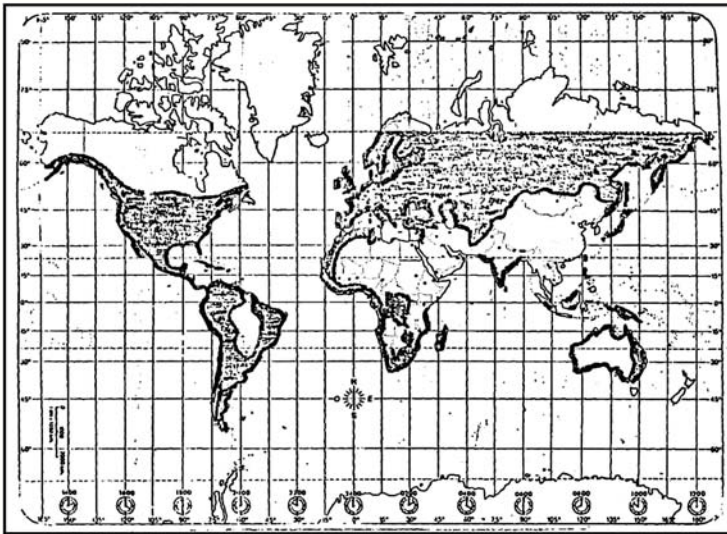

Figure II

126. Before 1939.

masonry, a synarchic organization that, contrary to common belief, was opposed to the eradication of European Jews. The reason is eminently esoteric: the function that, in the planetary anatomy, the Hebrews fulfill consists in producing a *collective* contact between the “emotional body” of the Earth and the consciousness of the Demiurge; *and this function can only be effective if the Diaspora is maintained, i.e., the worldwide “dispersion” of the Jews.* In Figure II we have represented, by means of shaded areas, a current picture of the world distribution of the Hebrew Race that demonstrates, in an eloquent manner, *that the principal objective of the Jewish strategy is not Zionist, but synarchic.*

E.

Let us now recall what we were saying in “Introduction to the A2 Strategy”: *“The mission of the Mongols in History is to ‘push’ the Hyperborean lineages of White Race ‘toward the Kaly Yuga.’”* In light of what has been seen so far, it should be clear by now that it is indeed possible to “advance toward the Kaly Yuga” by traversing the different Regions of the Route. And that is what has occurred, an advance toward the Kaly Yuga, for many peoples of Hyperborean lineage every time a Turanian invasion forced them to abandon the lands of the East. Although such a “push” toward the West has been repeated on countless occasions since the most remote antiquity, let us recall only, by way of example, some of the events protagonized by the Turanian Races in the present Christian era, thus verifying that the displacement always follows the Route of the Kaly Yuga: in the fourth century, the incursion of the Huns into Europe leads to the Germanic invasion of the Roman Empire; in the ninth century, the Magyars, coming from the Ural Mountains, invade Transylvania, “pushing” westward the Germanic and Slavic tribes that were inhabiting that region; in the thirteenth century, a Mongol Empire under the command of Genghis Khan attacks Armenia, Russia, Poland, Hungary, Silesia, etc. From the fourteenth century, a great Turkish expansion begins to press on the West, ends with the Eastern Roman Empire in the fifteenth century and, in the seventeenth century comes to occupy Vienna, etc., etc.

If History is eloquent with regard to the affirmation of 2º, on the other hand, it is not evident—and we will try to clarify it—what objective such invasions of the Turanian Races pursue,

given that they have always been provoked by the Hyperborean Siddhas. The strategic objective—which, naturally, was also contemplated in the Führer’s General Strategy—was the following: to put an end to the Kaly Yuga. For this purpose: the Hyperborean Lineages of White Race must enter the Route of the Kaly Yuga until reaching the maximum darkness and then, from there, they will have to transit the Route in the inverse direction, toward the East, under the command of a Great Chief who raises the Total War against the Infernal Potencies and achieves for the Race, in the heat of the combat, the definitive mutation, the magical change that transforms the animal-man into a semi-divine Hero and the Hero into an Immortal Siddha.

This objective has been proposed by the Hyperborean Siddhas for thousands of years, but only recently, thanks to the Esoteric Chorology of the **⚡** and its discovery of a Route of the Kaly Yuga, has it been possible to comprehend the occult reasons behind it. And that is why, based on the Hyperborean Wisdom, which is the mother of the **⚡** sciences, we can affirm that the Führer’s General Strategy contemplates *a last attack on the West by the Turanian Races, before reaching the end of the Kaly Yuga.*

That time it will be the Siddha Anael, who, at the head of enormous Mongol armies, once again hoisting a banner with a Polar Sign, will irresistibly advance along the Route of the Kaly Yuga. But the little Judaized men, sunken into the darkness of blood confusion, *will not see the Sign or understand that the end has arrived.* They will believe, until the last moment, that they witness the advent of the Synarchy and will foolishly rejoice in it. They will only react when, incredibly, *from Berlin, they see arise an army of immortal men who wear the uniform of the eternal ⚡.* But then it will be too late, for they will deploy in all directions, possessed by a Berserker Fury... *and will only respect the Sign of the Pure Blood.*

F.

A Strategy of the Siddhas consists, then, in “pushing” the Hyperborean Lineages of White Race “toward the Kaly Yuga” by employing, for this purpose, the Turanian Races, coming from the center of lesser intensity, as a “tactical mass.” In order to prevent such an objective, the Synarchy has at all times procured to keep the horizon of the Kaly Yuga “at a distance” by

deepening the exploration of the Regions of the Path. And with such a motive, one of its infernal agents, a Jew known as Christopher Columbus, in the fifteenth century, prolongs the European transit toward Region VI of the Route; see Figure 10.

This is the secret objective of the “discovery” of America, which we mentioned when outlining Dr. Dee’s Project Thule, but which was then impossible to explain without resorting to the elements of Esoteric Chorology, such as the geochronic concept of the Kaly Yuga or the Chorography of Figure 10.

The Synarchy has thus tried to ensure that the Strategy of the Siddhas—“to march toward the West and then to return, by Blood and Fire, toward the East”—is hindered by the water barrier that the Atlantic Ocean places between Regions V and VI. In this sense, the “discovery” of Columbus has been successful (but this is relative, since England and Ireland, for reasons that we will not discuss here, respond to chorological characteristics of an authentic Region VI, a quality that has enabled leaders such as Napoleon or the Führer to plan strategies that exclude America as a war objective).

G.

In Figure 9, a tri-continental triangle has been outlined, the vertexes of which are located in Peking (Asia), Algiers (Africa), and Buenos Aires (América), and which, taking into consideration the continents’ initials, is called: “the three As.”

We already spoke, in the Second Dissertation, of the ANAEL Order of South America, founded by the Hyperborean Siddhas after the catastrophe of the Second World War. According to the directives given to the Order in 1946, the Siddhas would promote in the world three focal points of conflict *outside of the Synarchy’s control*. These three focal points would not be located on the Route of the Kaly Yuga, where the parody of an East-West “confrontation” would be executed in order to favor the Synarchy’s plans of a World Government, but outside of it, and that is why the peoples involved in the conflict would be called “Third World” or “supporters of the Third Position.” The three focal points, which in the ANAEL Order were called “liberation vertexes,” went into effect after a few years: that of Peking in 1949, after the revolution of Mao Tse-tung; that of Buenos Aires in 1946, after the electoral triumph of President Juan Domingo Perón; and that of Algiers in 1962, because of its independence from France.

To comply with the proposed objectives, these “liberation vertexes” should be organized on the basis of a National Socialist or Fascist principle, i.e., with a policy that favors social justice “inward” and defends national interests “outward” from the borders. But the main thing would be that, starting from the liberation vertexes, the conflict would spread to other focal points of similar social composition. Such an effect was sought not to favor “the revolution” (since such national-socialist liberation movements would operate outside of the socialist, communist, or Trotskyist internationals), but to balkanize the areas of conflict with myriads of “independent” or “liberated” countries that would render inoperative, with their contradictory votes, the United Nations or any other similar synarchic organization.

The Chinese Revolution achieved this objective in Asia, but its most important role *was to prevent a Russian invasion to the center of lesser intensity*, which could come from the USSR itself or from Southeast Asia. ANAEL’s Directive of 1946 was saying: “China and Africa constitute the body of a New World Order that will arise from the chaos of the West, but without the pressures of the Kaly Yuga” and later: “Hispano-America will be the head of that new civilization, the Will of the Siddhas is committed to it.”

China and Africa fulfilled their part of the Siddhas’ plan in the 50s and 60s: what then occurred with Hispano-America? Here the project was not new, for already in the nineteenth century Simón Bolívar had understood that without a South America united in pursuit of nationalist and patriotic objectives it would be impossible to resist the pressure of the great imperial Potencies, and without such a union, any possibility of political, economic, or cultural independence would be a pure utopia. The ANAEL Directive for Hispano-America was based on similar considerations and that is why, from 1951, powerful spiritual forces converged on three important personages who were fundamental pieces of the Hyperborean Strategy: we are referring to the Chilean president Carlos Ibañez, the Brazilian president Getulio Vargas, and the Argentine president Juan Domingo Perón. These three leaders tried, between 1951 and 1954, to carry forward a geopolitical plan called “ABC” (Argentina – Brazil – Chile), elaborated by the Anaël Order of Brazil, which consisted, simply, in forming, with the three countries, an axis—the sloping “L”—that would

allow resisting the pressure of the Anglo-American imperialism. The ABC axis was contemplating the political, economic, and social integration of the three countries who would thus consolidate the third “Liberation Vertex.”

Naturally, that plan failed after a sinister conspiracy would lead Getulio Vargas to suicide in 1954 and another no-less-sinister synarchic counter-revolution overthrew President Juan Domingo Perón in 1955.

What are the current alternatives of the Siddha Strategy for the Third World? We could say, chorologically, that the Triangle of the three As has “rotated” and that its vertexes now point to other spiritual centers: the Peking Vertex has moved to the “Kaly Yuga’s center of lesser intensity,” in Mongolia; the Algiers Vertex is now in Tripoli, Libya; and the Buenos Aires Vertex, although it is not yet completely clear why, has moved to Santiago, Chile. From this last country will arise, then, the head of a new Hyperborean Civilization of a tri-continental scope, although, in order to do so, it must first rise above the nations of Hispano-America and convoke them around a joint project of liberation.

The Current Secret Route of the Kaly Yuga and the Triple “A” Triangle. Santiago – Tripoli – Ulaanbaatar



Figure 12

Fourth Dissertation

Treatise on the **⚡** Psychosocial Strategy

Section 3

Prologue



his manual has been developed to update the *Wewelsburg* kameraden on new aspects of the **⚡** Strategy. It is the fruit of a long effort carried out by specialists of diverse branches of knowledge, all oriented toward a precise objective: to establish the *Systematics* of the **⚡** Strategy.

The benefits of such an effort are evident: if it is possible to *systemize* the **⚡** Strategy, a great part of it could be presented as an axiomatic science and would make possible, then, the intellectual access to profane persons. Until now, in order to master elements of the **⚡** Strategy, it was necessary to receive the Hyperborean Initiation in Wewelsburg but, in view of the imminence of the Total War, we have been persuaded to consider the possibility of instructing *non-initiated* kameraden for this one time only.

Thus, in keeping with the mission entrusted by the Führer to the **⚡**, we title the science that we present here for your consideration, “Psychosocial Strategy.” But such a title should not be misleading: the only “Strategy” of the Third Reich is the Führer’s General Strategy. The Psychosocial Strategy of the **⚡** is a particular or “field” strategy, only applicable in the framework of said General Strategy, under the leadership of the Führer and thanks to the racial conceptions that the Hyperborean Wisdom of the Thulegesellschaft offers. As can be noticed, various are the conditions for this effort to bear fruit, as is explained more extensively in the different subsections of this manual.

Until the end of the eighteenth century, and up to Clausewitz, all military theorists were making strategy a “law of war,” preferring to call the set of actions coordinated by a nation in times of peace, “political.” This dualistic conception was arising from the erroneous belief that only war was implying the existence of *conflict*, in other words, a *crisis* was recognized when it was unavoidable. Therefore, strenuous efforts were made to maintain “peace,” that is to say, to avoid armed conflict, but everything that was arising from diplomacy was a dead letter from the hostilities because two “ideal” states, war and peace, were artificially and manichaeantly separated. The

Latin proverb, "*Si vis pacem, para bellum*" ("If you want peace, prepare for war.") was, of course, considered immoral.

Two events of the nineteenth century change this panorama. The first originates in the French *Revolution* and the Napoleonic Wars when, giving birth to the appearance of "nationalism" in Europe, the peoples erupt in order to actively participate in the war. More than the iron discipline of the troops, professionally and traditionally under the command of a Noble or Seigneur, what matters now is the "morale" and the "patriotic fervor" of the soldier, nonetheless considered as a mass or a mob. The mercenary combatant disappears, swept away by fervent peoples who want to participate in wars to "defend their borders," their "flags and patriotic symbols," or their "national traditions," all concepts that no one knew a day before. As a consequence of this popular participation, wars become "total," involving the totality of the population in the conflict.

The second event is the philosophical and doctrinal formulation that Karl Marx and Frederick Engels postulate to raise the class struggle as a permanent conflict in History, and its dialectical "synthesis": the dictatorship of the proletariat.

According to these authors, the accumulation of wealth in the hands of an increasingly greedy bourgeoisie strengthens that social sector or "class," which generates, by the merciless exploitation that it must make of the producing worker and by the laws of surplus value inherent to financial capitalism, a new miserable and "dispossessed" class: the proletariat. As it is, according to Marx, a "law of nature," such as "the law of gravity" or "Ampère's law," the "proletarian class" and the "capitalist class," dialectically opposed, end up confronting each other, which is the way in which the "opposites" resolve their conflict. From this confrontation between a thesis (capitalism) and an antithesis (socialism) arises the synthesis, that is scientific socialism or communism with its inexorable political consequence: the destruction of the capitalist class and the taking of power by the proletariat. Both events, the advent of "bourgeois nationalism" and "scientific socialism," form part of a satanic plan that is systematically applied from all corners of human society by thousands of members of the synarchic Secret Societies and by the Jews, the "Chosen Race" of Jehovah Satan.

What is the objective of the synarchic plan in raising the two mentioned events? To force the *social leap* from *evolution* to *revolution*. That is to say that, “evolution” being a law by which the material “creation” of Jehovah Satan is governed, the “revolution” has as its purpose to accelerate previous evolutive processes, “matured by the action of time”: and to arrive at constant social “changes” that facilitate the conclusion of the synarchic plan with the foundation of the World Government of the Synarchy.

A clarification: these revolutionary “changes” are purely mechanical and have nothing to do with the “charismatic mutations” extracted from the Hyperborean Wisdom, which we will study in our Psychosocial Strategy.

Returning to the two mentioned facts, it can be seen, in light of them, that the traditional concepts of “war” and “peace” are turned upside down. “Nationalism,” the people’s mass perception of the national being, their active participation, alters the disciplined and geometrical development of warfare until then, giving rise to the appearance of “battles of annihilation,” with disorderly but very numerous troops.

The “social revolution,” the uprising of the proletarian and peasant masses, the “red unions,” all the subversive and revolutionary machinery of Marxism, alter the development of peace until then, giving rise to the appearance of the “fighting proletarian” and their “tactic of struggle”: terrorism. If any citizen can become a “revolutionary” and fight against the State, it is understood that a society lives, according to Marx, in a state of permanent war given that “defense” is a mode of war and every modern State will arrange the way of defending itself from its internal enemies in “times of peace.”

New ways of waging war between nations and a worldwide agitation of the masses, induced to unleash revolutionary war, justly called international, speak of the disappearance of the precise limits in which war and peace were previously divided. It is a new strategic conception that is imposed in the nineteenth century, the characteristic of which is the change in the objective of the struggle: before it was common to fight for the right to territorial sovereignty and the emerging power of such situations of force, an objective that was hardly varying in the “religious wars.” From the two mentioned facts, the confrontation will be for *ideologies*. Strategy thus came to play an important role in nations that have lost sight of the limits between

the state of peace and of war and that struggle to impose their ideologies on the adversary or to free themselves from enemy ideologies. The totalizing strategies of modern potencies, at the end of the nineteenth century, have absorbed politics, economics, military action, etc., and form large and complex plans of action in order to fulfill national or synarchic objectives. It could be said, taking into account this new dimension of strategy, that “the exterior conduct of a nation is a faithful expression of its totalizing or overall strategy.”

From what we have seen so far, it can be inferred that the theater of operations of a modern war has annexed a space that it was not possessing before: the “civilian” ambit on the physical plane and the “mental” ambit on the psychic plane. The struggle continually changes fields, or rather, invades other planes: the soul of the nations, the collective psyche, the personal unconscious, all terrains suitable for new strategies of revolution and counter-revolution. It is now important to count on the “conviction” of the “mass-man,” on his behavior in “organized crowds.”

New weapons thus arise for this modern war of ideologies: propaganda, psychological action, agitation, etc. Their tactical objective is no longer to kill the body, but the spirit; to subjugate it with the “contagious power” of subversive and revolutionary or bourgeois nationalist ideologies; to implant in the “interior of man” recurrent ideas that mechanically work, making of him a slave more abject than the proletarian slavery that Marxism intends to conjure up.

And these fearsome weapons are no longer created by military engineers but by thinkers: philosophers, psychologists, sociologists, etc., who investigate gregarious phenomena, discover relationships and postulate laws. It is established, for example, that the collective behavior of the masses obeys impulses emerging from the *unconscious* and, being that the *content* of the unconscious is made up of *symbolic* material, it is necessary to resort to laws of *analogy* for its interpretation and praxis. With this *instrument of analysis*, the analogical interpretation of semiotics, we seek an element *common* to the members of the masses in order to *operate on said element* or *replace it* if possible.

This common element, the comprehension and mastery of which would give an unsuspected power to the leaders of peoples, is Myth. But not only is Myth an important object of

study, but also its “ambit of action,” the “collective soul” (Gustave Le Bon), also called “l’esprit grégaire” (L. Charpentier), “psychoid collective unconscious” (C. G. Jung), “eggrégore” (É. Lévi), “group soul” (Max Heindel, R. Steiner, or other synarchs), *linga śārīra* (Vivekananda and Patanjali).

The Synarchy, which decides to launch its final offensive in the twentieth century, presents a strategic front made up of three tactical wings: on the right, the liberal or Judeo-liberal wing with its Masonic Secret Societies and foreign policy apparatus; in the center, the Zionist wing that is eminently Judaic and gathers hundreds of secret organizations of the *B’nai B’rith* type; and on the left, the Marxist or Judeo-communist wing with the whole apparatus of worldwide subversive and revolutionary terrorism.

The main objective of this formidable strategic front is to take over, physically and ideologically, the nations and peoples of the world in order to organize, by the end of the twentieth century, the World Government of the Synarchy. In the execution of the synarchic Plan, all the “black” variants of modern warfare are contemplated, from the collective idiotization of “warlike” nations by means of massive drug running, to plain and simple genocide, including the always-useful communist Bolshevization, which has yielded such good results up to now.

All this is possible because the Synarchy masters truly effective psychological techniques of action, has at its disposal contagious “Myths” like that of the “general strike”¹²⁷ or that of “social equality,” and counts on the invaluable help of the Secret Societies embedded in the whole social fabric of humanity. And also because of the nature of Jehovah Satan’s “occult hierarchy” that the Synarchy holds, which is already, in fact, a Secret Government on Earth, from its “Shambhala” center.

The Hyperborean Siddhas *would not intervene* against this diabolical Plan except through the mediation of the most enlightened Viryas of humanity, who cry out, in the mystery of the Minne, for the lost heaven. The Hyperborean Wisdom says that even if it is only one, among millions of lost Viryas, the one who cries out to the Siddhas and to Khristos LúCIFer, will be guided in the eternal return toward an interior path of redemption. In this case, it is a whole race that attempts to transmute its miserable slave condition to which the Demi-

127. Or, “work stoppage.”

urge Jehovah Satan has subjected it, and which has chosen a Führer so that he may lead it to victory.

But this Hyperborean Race, which demands its luciferic redemption, is no longer the “Aryan Race,” but almost all the branches that make up the great Indo-Germanic White trunk and some parts of the Yellow and Black Races. And the Führer, recognized by all as the leader of the Hyperborean peoples, is the bearer of the General Strategy that ensures the final success.

We have made a review of the emergence of a “new synarchic strategy,” in the nineteenth century, characterized by an ideological confrontation, i.e., that the objective of modern warfare is no longer “annihilation” (Napoleon), or “to impose our will on the enemy by an act of force” (Clausewitz), but “to impose our ideology on the enemy”; a theme that will characterize modern conflicts where the synarchic indoctrination of the masses will be considered essential. This “struggle,” as we have already said, is forced by the Synarchy in order to generate the dialectical game of ideological opposition and to profit from the resulting synthesis.

The Führer, in this circumstance, has decided to wage a total war against the Synarchy on its three wings, but accepting the “laws of the game,” that is, the ideological struggle, without revealing the real objective of his General Strategy. This objective, highly secret, is also incomprehensible to the Paśu and other members of the Synarchy because it consists of the double purpose of seeking the collective mutation of the Race and putting an end to the Kaly Yuga.

It will not be an ideological opposition but a conflict of *essential principles*: the Hyperborean Wisdom opposed to the satanic Synarchy.

Section 33



he General Strategy of the Führer is known in its totality only to him and all other strategies, political, economic, diplomatic, psychosocial or military, are partial strategies that can only respond by themselves in the plans and tactics set to achieve their own objectives. The Führer sets the objectives of each particular or “field” strategy according to the *secret principles* of his General Strategy and they are carried out by social bodies duly constituted for that purpose; an Office of Foreign Affairs for fulfilling an “economic strategy”; a Race and Settlement Main Office for a “social strategy”; a Ministry of Propaganda for a “political strategy,” etc.

In this context of field strategies, we must place the Psychosocial Strategy of the **⚡**, which we will study in this manual, and which has the objective of *establishing techniques and means of crowd-control based on the Hyperborean Wisdom*, making clear the existing *irreducible difference* with the synarchic strategy.

This manual deals, now we can say it with more precision, with the principles and laws of the **⚡** Strategy, elaborating the topics from levels of easy comprehension to deepening into the most complex aspects of the Hyperborean Wisdom. We hope, then, that it is to the liking of the Wewelsburg kameraden and that you fill out, at the end of its reading, the attached form in order to know your opinion, remembering again that in the case of it being positive, we will proceed to divulge these secret techniques to non-initiated officers.

Section III

Absolutely Collective Professions



Let us make a conceptual summary of what we have seen in Section II, before continuing.¹²⁸ We already know what it is to be a professional: the link between oneself and society, according to a described archetype; therefore conscientialized, in the training plan, which consists of a “specific knowledge” (being) and one’s “appearance of knowing such a knowledge” (form). So-called professional ethics, for example, corresponds exclusively to the sphere of appearance (form), as well as any precaution of a moral order (idea of “service,” “good” use of science, etc.) because pure knowledge (being), as such, is universal and amoral. We also studied the risk that the psychic inflation in identifying oneself with the professional archetype entails: the loss of individuality. We also said that this risk is reduced by establishing a *social time* (schedule) in which the man adopts the professional “form” (appearance) and exercises it effectively, after which he resumes his ordinary personality. The limits of this *social time* act unconsciously as a psychic fence for the overflows of the archetype: we conclude then that it is “normal” for a man to set the limits, if not of his conscience, at least of his profession and, in fact, millions of men behave in this way.

But can this always be done? Is it absolutely possible for all professions to escape the identification with the collective archetype?

For the large majority of human professionals it is, but there are activities that, while still being professions, cannot be included in the considered general case. For example, is an artist a professional? In a certain way yes; he exercises a trade, perhaps he makes a profit with his art, he fulfills a social role; there is, in a word, being and form, knowledge and appearance. But, it is said, at no does an artist cease being an artist and it is obvious that no one can really be a poet only at a cer-

128. If the reader is wondering why what follows in the text as a summary of the noticeably shorter Section II does not seem to have been previously mentioned in said section, it appears as if parts of the surviving manuscript are missing, which may be the case with other sections as well.

tain time. The same is true for the painter, sculptor, musical composer, etc.

This difficulty is removed by saying that the artist is a professional who surpasses the profession by virtue of being in possession of a “*creative capacity*.” Thus a distinction is made between the musical composer and the performing musician, between the copyist and the painter, etc. The artist adds creative inspiration to a professional (technical) base.

And what about the priest (curate, rabbi, pastor, ayatollah, etc., professional)? Here the question becomes more acute, but it is said that the priest adds a *mystical vocation* to a professional base (knowledge of dogma, worship, rites, etc.) that puts him in contact with divinity. Of course, a priest is always a priest, at all times and in all places. And we all accept this without thinking. Another example: a military man. Is he a professional? We are as in the previous cases of the artist and the priest, but here there may be some uncertainty because of the abuse of the term “professional” in military jargon. It is said for example, “the military man is the professional of war” and the military man is always referred to “as a professional,” although it is not very clear what is meant by that. A vulgar meaning of the term profession alludes to one “who makes a living from some thing” or one who lives by a profession or trade; this interpretation is surely the cause of the misuse of the term. Because a military man is always a military man as a priest is always a priest and an artist is always an artist.

Lastly, the same can be said of the judge, who is not only a public official, for no one is a judge if he does not possess a “sense of justice,” something that cannot be taught in the training curriculum and that, in fact, differentiates him from the simple lawyer who only knows the law. And so we also say that a judge is always a judge.

We could go on and on, but with what has been said, we can grasp that in all the mentioned cases, the professional level is exceeded by the personal contribution of a transcendent virtue; the artist with his inspiration, the priest with his mysticism, the judge with his sense of justice, the military man...? What transcendent virtue does he have in order to affirm that he exceeds the professional level?

Before responding, we will say that from here on we will take, for the analysis, the figures of the priest and the military man because “the judge” is a figure of recent appearance, his

functions (legislator) being fulfilled in antiquity by some of the first two or by “the King,” another figure that shares the previous concepts. The artist, on the other hand, is atypical for our objective.

Having clarified this, let us go to the response. We will say that the Indo-Aryan peoples, who make up the ethnic substratum of what is called *Western Civilization*, were possessing, since ancient times, the concept that society should be organized on the basis of the harmony of three collective functions: priestly, regal, and warrior. In India this concept is the basis of the caste system, with the Brahmin caste corresponding to the priestly function and the Kshatriya caste to the regal and warrior function.

These functions are linked to collective archetypes, which of course are not described in any training plan but can be seen portrayed in the great mythical figures (generally divine, sometimes historical). For example, for the regal function we have king Gods like the Greek Zeus, the Roman Jupiter, or the Hindu Pandu. For the priestly function, for example, the Greek priest God Hermes or the Iranian Zoroaster; and for the warrior function, hero Gods like Indra in India or Mars and Ares in Rome and Greece, etc.

And here we will answer the question concretely: as long as the military man is defined by the warrior function, he will transcendently participate in the manifestation of a mythical archetype, he will put himself in contact with a warrior deity, and he will exceed the mere professional level. This is why the priest and the military man are analogous, both depend on a *Mystique* in order to transcend the vulgar plane of social and professional convention, which they will achieve as long as they “adjust” to the requirements of the collective Archetype or Myth.

We have said, on the one hand, that society protects (limits) the professional by regulating the *social time* (schedule), avoiding an excessive identification with the archetypal collective and, on the other hand, that priests and military men escape this protection by demonstrating a typical permanence beyond every *social time*, a fact that is accepted by all and even encouraged. It would not occur to anyone to think of a military “professional” who is not such a thing “off-the-clock” and refuses to act as any professional may do, e.g., a lawyer consulted “off-hours”; the same is true for the priest. It is appropriate to

ask again: why does society regulate a *social time* for some professions and eliminate it for others (or “weaken” its limiting sense)? The answer is simple. In Western society, the direct heir of the Indo-Aryan tradition, all professions must be regulated by a *social time* except those that fall within the priestly, regal, or warrior functions, since these functions constitute the foundations, the scaffolding, on which society itself is built. “Full-time” men are needed here and the elimination of these temporal limits to professional action makes it almost impossible to discover the “man” who is “behind” the military man or priest. In fact, this identification is deliberately sought, for although the members of society can exercise professions only at determinate *social times*, society itself, with its priestly, regal, or warrior functions, must exist at all times, as must as the members to whom this function has been delegated (priests, kings, warriors). There is then a loss of individuality in the priest and the military man in favor of taking on a permanent collective function. Society compensates for this “loss” by accepting, or demanding, from the priest and the military man a decrease of individual responsibility in the fulfillment of their function. Thus the priest will say “if I say so, God says so,” something that no one will dispute. And the military man will be able to say “I follow orders,” which no one will attempt to verify. Individual responsibility is relative when performing a collective function, contrary to a professional whose activity is developed in a specific *social time* (schedule), who must respond responsibly and individually for everything that he does or says.

There is a “loss” of individuality and society compensates for it, as we have seen, but does this loss signify that priests and military men are in large part possessed by a collective archetype? Undoubtedly it can be answered in the affirmative, since all of our analysis proves it and this fact constitutes one of the laws of the Psychosocial Strategy.

The problem here (and the key to the whole question) lies in the fact that the collective archetype to which priests and military men conform is in the collective unconscious. This is very different from the case of the professional collective archetype that, as we have already seen, is “described” in training curriculum and therefore conscientialized.

The professional rarely exceeds the limits of said “description” because he must preserve the “form,” the appearance,

and, on the other hand, he can easily get rid of this mask if he has not essentially identified himself outside of a *social time*. This leads us to the following statement: "In the professional there is a *predominance of being over form*, of knowledge over appearance. In the priest or military man there is a *predominance of form over being*, of appearance over essence."

Thus, the improvement (actual progress) of a professional takes place on the level of intellectual knowledge, of wisdom, which corresponds to the being of its collective archetype. Form (professional appearance) is a "set" condition, socially established and subordinated to being (knowledge). Only a "sage," who has far exceeded the level of professional knowledge, is allowed to "neglect the appearance (form)."

On the other hand, the epochs in which is noticed an "advancement" of the warlike function over others (militarism, military State, Empire) are characterized by the exaltation of military "forms" (eye-catching uniforms, display of war tools, proliferation of flags and banners, etc.). The same when the priestly function exercises temporal power, an exaltation is observed of purely material religious "forms" (rich ritual vestments, magnificence in the temples, etc.).

Exaltation of form, we say; and what about being in this collective archetype of the priest or military man, which belongs to the collective unconscious? Being is subordinated to form as in all cases in which one wants to reveal or discover a transcendent being by means of semiotics or analogy. An unconscious archetype can only be "seen" collectively in the world by means of its symbolic projection on the concrete; but this projection will be fundamentally "form-al" with the aim of imprisoning being in the limits of form, of anchoring it in the world, awaiting its subsequent emergence. That is why in religious or warlike activities the formal is exaggeratedly exalted over the essential, in order to magically force the manifestation of the archetype.

A priest who must undertake a missionary action will present himself with habits or tunics of the appropriate color, bearing sacred signs, demonstrating ascetic virtues, etc., because the believers in the presence of this formal image will project their own unconscious religious archetype by transferring to the priest the attributes of the Archetype or Myth.

Before religious initiation (intimate contact with the myth) every adept is "formally instructed" because without a prior

preparation there is no guarantee that ascesis will take place; it is necessary to con-form everything into a symbolic schema, to become a symbol oneself, so that the archetype, myth, or divinity manifests itself. This is also the principle of ritual and ceremony (religious or magical), which aims to achieve, by means of an arrangement or order of exterior actions (formalism), the transcendent contact with the divine. But the [...] ¹²⁹ of a rite pursues a more complex objective than the mere individual experience: by means of a certain ordering or re-ordering (new order) of the concrete world (material plane), it seeks to produce a transformation of the latter by making it similar to the other world (spiritual plane) within the formal limits of the ritual action. If the ritual achieves its objective, it will generate, in the first place, a special “climate,” which is “not of this world,” perceptible to all officiants (and sometimes even to some lay spectator). This is the “sign” that the plane has been transcended, that two worlds have made interference, intersection, or contact. From this point on, the “door is open” for multiple individual and collective experiences.

On the other hand, the shape of the shield, the design of the sword, the ornaments of the helmet (feathers of sacred birds, studded with “magic” stones, etc.), the garb, all contributes to portray a warrior “form” of high symbolism that tempts the double purpose of awakening combative virtues in the one who wears it and instilling fear in the enemy. To this presentation are added techniques of individual (and collective) combat with much influence of those rhythms and cadences of nature that by their character of violence or aggression can awaken primordial fears in the enemy. The warrior will “move” and roar like a panther, he will run “faster than the wind”; his “cry will be as fearsome as thunder”; his arm will have the “strength of the bear;” etc. There are also warrior rituals with the practice of dances that resemble the eagle’s flight or the lion’s leap; with the emission of onomatopoeic sounds of nature; with the intervention of fire, etc., thus doing everything possible to evoke the collective archetype of the warrior, who here will undoubtedly be a divinity, a God of war.

It is clear, then, the importance that form has in the institutionalization of the priestly or warrior (military) function and why it is so: because society must ensure the effective manifes-

129. This word is missing from the manuscript.

tation of collective archetypes that are in the collective unconscious.

The guideline of the extent to which the collective archetype of the priest or the military man is in the collective unconscious is given by the fact that in historical periods in which power is evenly distributed among the three functions, priestly, regal, and warrior, we see the people's community collectively identify with the king, the priest, or the warrior who holds such a power. A people can be "spiritualized" or "militarized" by the synchronic actualization of a religious or patriotic (unconscious) archetype, but a people will never advocate for, engineer, or cure themselves, because these collective archetypes are conscious, they are described, and their action is controlled by a *social time* (schedule).

Lastly, let us note that all the above-mentioned "formal" attempts, which were made in order to evoke the unconscious collective archetype of the priestly or warrior function, would be useless without a suitable *Mystique*. Let us specify the meaning that said term possesses, according to the Hyperborean Wisdom.

Section IV

The Hyperborean Mystique, Magical-Social Engine



ysticism is an attitude of man toward Divinity; an attitude that leads to an ultimate interior experience called *mystical ecstasy* (or *mystical union*) in which the personal bond between man and God is established. In order for the mystical attitude to conclude in a mystical ecstasy and for the transcendent interior experience to take place, a mediating agent called *charisma* must intervene.

Let us recall that the mystic is not “initiated” and, therefore, a layman, but the transcendent experience that he pursues and obtains belongs to the most exalted order of esoteric gnosis, so that the *charisma* must overcome, as in initiation, all the obstacles (rational, moral, biological, etc.) that stand between him and Divinity. The charismatic agent intervenes in an apparently gratuitous and contingent manner upon certain mystics, this intervention being so incomprehensible and inscrutable that some profane thinkers attributed it to the whim of God, rightly calling it a “gift from God” or “divine grace.” But the Hyperborean Wisdom, the pale reflections of which survive in some esoteric traditions, affirms that the *charismatic agent* is perpetually present on a plane “absolutely transcendent” to the immanent world of matter and is called the *Paraclete*. It is what Christian theology has called the Holy Spirit, mistakenly including it as one of the “persons” of the Trinity, i.e., an aspect of *YHVH-Satan*. The Jewish Kabbalah also perverts the absolutely transcendent quality of the Paraclete by tying it to the pantheistic immanence of Jehovah Satan. We will see later a definition of the Paraclete when studying the Hyperborean Metaphysics of the *Thulegesellschaft*; for now let us continue to specify the concept of *Mystique*.

The Hyperborean Wisdom teaches that the Paraclete, or “charismatic agent,” is sympathetically bonded to the blood, to a *reminiscent content* that some beings possess and which is called *Minne*: the inheritance of the Symbol of the Origin. Hence the apparent lack of “worldly logic” in the manifestation of the charismatic agent because it only intervenes in those mystics who have “felt the reminiscence” that grants the blood *Minne*. Not everyone can feel the *Minne* and many who feel it do not know that they feel it.

To feel the Minne is to access its gnostic content and this is only achieved when, immersed in the mysterious torrent of the blood, there is a reencounter with a forgotten truth, i.e., made unconscious. This reencounter is not necessarily a memory but the reminiscence of one's own lost divinity (Vril) and the intimate certainty of belonging to another order of spiritual existence for which matter is detestable and the reality of the world is essentially evil. An infinite nostalgia immediately follows the reminiscence, which can only be mitigated by the hope of the return.

The Minne, then, is not so much the memory as the reminiscence and even the nostalgia that must be intimately experienced as an act prior to the mystical ecstasy, which is reached through the charismatic mediation of the *Paraclete*. That is why the Hyperborean Wisdom sustains a broader concept of charisma in the meaning of a *personal attribute* that can be conquered and developed for one's own benefit and for the benefit of the Race. Personal charisma would be in this case "the sensitive-effect product of the charismatic agent's or Paraclete's acausal intervention in the mystical ecstasy, an ecstasy that is only possible to experience if one has previously experienced the blood Minne, that nostalgia." From this concept there is a whole secret technique, which allows the development of a personal charisma, based on the possibility of accessing the Minne by means of the "Hyperborean Principle of the Purification of the Blood." This principle alludes to the *astral blood (fanhema)*, the subtle complement of the physical blood and the intermediary between the Spirit and the physical body. According to said principle, the Minne is not present in all anthropomorphic beings but in those "descendants" of the Cosmic Hyperborean Race, of Khristos Lúcifer, the only ones who deserve the qualification of semi-divine men or Viryas. But, even in these, there are various degrees of impurity in the *astral blood* or *fanhema* that hinder or prevent access to the Minne and its liberating nostalgia. It is then necessary to purify the astral blood so that the "memory contained" in the Minne may manifest. This is achieved by means of Secret Techniques that contemplate the possibility of knowing exactly if the man is of Hyperborean lineage (Virya) and, if so, what degree of impurity in the astral blood obscures the "memory contained" in the Minne.

The Hyperborean Wisdom affirms that if a Siddha wishes, during the Kaly Yuga or Dark Age, to recognize the Hyperborean lineage in races degraded and degenerated by “*blood impurity*,” with a view to their purification and regeneration, He has at his disposal only seven possible ways, one of which requires the effective possession of the *Gral*. The Secret Techniques, which are also seven, one for each way, make possible the purification of the astral blood to such a high degree that they can bring about the transmutation of the *Virya* into a *Siddha*, i.e., of the semi-divine man into a Divine Hyperborean immortal.

In another order, it is also possible to develop the personal charisma of a leader so that, in leading a people, he exercises, over the mass of the people, that charismatic fascination of the great chiefs. Even a ruling elite could be charismatically endowed if there is some way for the selection of *Viryas* and the Secret Technique is applied.

Let us now clarify a widespread error that consists in analogically relating personal charisma with physical magnetism, in the belief that the latter behaves like the former. In this crude scientific analogy, the charismatic man possesses an intense “force field” that is perceived by other men thanks to the “interference of fields” that is produced when they place themselves in his vicinity. Such a man is then said to possess “personal magnetism” and charisma, like the forces of action at a distance in physics, is associated with the notion of magnitude and spatial extension. The Hyperborean Wisdom teaches none of this, but affirms instead that the personal charisma that a leader “transmits” collectively to the mass is actually perceived by each individual thanks to a phenomenon of synchronicity. This is the reason why personal charisma, however intense it may be, is never infallible but only affects those who, by their spiritual lineage and degree of blood purity, i.e., by the quality of their *Minne*, can perceive it to a greater or lesser extent. But this perception is not merely sensitive but eminently transcendent and spiritual, as it corresponds to a superior personal virtue, which is charisma and not a blind and deceptive force.

We now have a better defined concept of what a mystic (of Hyperborean lineage or *Virya*) is. The Hyperborean Wisdom assures us that every *Virya*, no matter how impure his blood may be, possesses potential mystical conditions that can be

“awakened” and suitably oriented for the benefit of the individual and the Race.

This “awakening” of mysticism can be induced by the personal charisma of a chief (*Führer*), leader, or guru, especially gifted. In fact, all the founders of religions and even the founders of simple religious orders, e.g., had a great personal charisma that enabled them to gather around them people of the most varied condition, who felt “drawn” to the new faith.

This charisma, which leaders possess to a high degree and which seems to be an indispensable element for guaranteeing success in leading communities and founding lasting collective organizations, is the principle on which a *Mystique* is based. In effect, a Hyperborean *Mystique*, or simply “*Mystique*,” is always the collective perception of a charisma, which in turn can be sustained by the presence of a visible leader or emanate from a small group of hidden persons. But, whatever the case may be, the charismatic bonding between *Viryas* always has as its center the blood, the Symbol of the Origin, which constitutes the common inheritance of the Hyperborean lineage. Let us clarify this.

When speaking of the esoteric and the exoteric, it is usually said that the latter is the profane expression of the former. Thus a religion is the external, profane, *exoteric* aspect of an *esoteric*, internal, initiatic *secret doctrine*, zealously guarded by priests or gurus from whom flows the charisma perceived by the faithful, which is called *Mystique*. But, while this is a true fact in the perpetuation of religions, in the beginning of the religious movement there may have acted only one leader (Mohammed, Jesus, Mani, St. Francis of Assisi, etc.), the possessor of a powerful charisma and expositor of a revealed Truth. Intellectually attracted by this Truth but, fundamentally, persuaded in their credulity by personal charisma, men group themselves harmoniously around that *center of power* that is the leader.

In these and in all cases, the *Mystique* is the expression of a charisma that, perceived by many, acts as a binding or organizing agent around the *object* of the *Mystique* (leader, church, doctrine, homeland, etc.). Let us look at an example. An army can be very well equipped and organized but demonstrate mediocre behavior in operations. The presence of a charismatic chief will revert this situation by introducing an adequate *Mystique* in order to raise the operational performance in or-

der to ensure victory. For this purpose, he will at first appeal to patriotism or faith. It does not matter too much, in reality, the conceptual content of his discursive and oratorical harangue because the Mystique predisposes men to believe, and on the other hand, as we have already seen, in the warrior (and priestly) function, “the form predominates over the being.” That is why the leader will clearly present the standard to follow and the example to imitate. The figure of a legendary hero, a God of war or a Virgin of the armies will be exalted, a divinity to whom it is necessary to imitate and from whom protection is expected. Slogans will be set, hymns will be sung, advances or parades will be undertaken, uniforms and distinctions, flags and shields will be designed, and other infinite variants of the “formal determination.”

In a short time an astonishing change will be observed. The army of yesterday, of dubious morale and unreliable efficiency, has been transformed into a war machine, into an organically disciplined structure, the operational performance of which is immensely superior. Such is the beneficial effect obtained by carrying out the function of command in the “framework” of a Mystique. But, on the other hand, the Mystique, seen in this way, is something clearly morphological, the perception of which gives rise to experiences of a transcendent order. This is to allude to the semiotic quality that the Mystique presents as a sensitive and intelligible form because, like the symbol, the Mystique reveals its being to whoever is capable of apprehending it. That is why we say that: “the Mystique is a form sustained by a being called charisma.”

Pages ago we defined Mystique as “the collective perception of a charisma, which in turn can be sustained by the presence of a visible leader or emanate from a small group of hidden persons.” For the benefit of the subsequent exposition, it is convenient to clearly establish what is understood by the “collective perception of a charisma” in this definition. Charisma is the expression of the Paraclete or Holy Spirit and *its memory can only be experienced* from the blood Minne. This means an absolutely transcendent and *individual* experience that we call *mystical ecstasy* and which is neither possible nor imaginable in relation to *the collective*, since this concept alludes to “any gathering of individuals.”

The perception of the Paraclete through its expression, the charismatic agent, is the supreme individual experience,

equivalent to what Dr. Jung calls the “psychic reintegration into the Self.” What do we mean then when we speak of a *collective perception* of charisma? Answer: that, in the “framework” of the Mystique, individual charismatic experiences, different and unique in themselves, coincide synchronistically in time and space. This does not at all mean that such experiences are *collective* in the sense with which we call *common experiences* or phenomena, the perception of which, one and the same, is shared by many, such as the observation of an eclipse or the hearing of a melody.

The Hyperborean Wisdom calls “charismatic bonding” to the fact of the charismatic coincidence in the framework of the Mystique, and this is the only concession that it makes regarding the collective.

Therefore, when in the framework of a Mystique, “charismatic bonding” is established among men, which is nothing other than the aforementioned “collective perception of the charisma,” this fact should be interpreted by giving to *the collective* the conceptual dimension of the *spatio-temporal coincidence of individuals* instead of the more common idea of mass or crowd. We are aware of the difficulty involved in this distinction so we will try to clarify the issue further in the next Section V.

For now, let us recall the thesis of Section III. There we demonstrated that in the priestly and warrior functions, “*form predominates over being*.” From this it is inferred that “by means of an adequate handling of the form, the being can be determined” in the priestly or warrior function, a possibility that constitutes the principle of the control of human groups in the Psychosocial Strategy. Now then: the Mystique being by definition “*a form that reveals a being, charisma*,” it is understood that the Mystique is the adequate *formal* instrument for operating on human communities with the objective of qualitatively “setting” the priestly or warrior functions or simply to “evoke” a determinate collective archetype. That is why the Mystique, as we have defined it here, is the system traditionally used by the great Hyperborean Guides of humanity, e.g., the Führer, who succeeded in producing the “charismatic bonding” in the totality of the German Volk.

Section V

First Law of the Psychosocial Strategy or Hierarchical Law

A. Considerations



W e know the existence of two very ancient ideas that both try to give a solution to the following problems: how to interpret the social conduct of man and the collective conduct of crowds? And how can these crowds be influenced, directed, guided, or controlled? These two ideas, opposed in their conceptual essence, have their origin in the deepest ancient wisdom and have been subject, like so many others, to the intellectual and rationalistic degradation of the Kaly Yuga or Dark Ages, i.e., of the whole time that we call the Historical Era. The first of them we have already elementally presented in *Section IV* as the concept of the Hyperborean Mystique; the second, which will be elaborated in this section, is also an ancient idea, as we will demonstrate in the following, but readapted to the “modern” mentality and reworked for its apprehension in psychologistic and pseudo-scientific semantic structures. Our purpose being to go on to present the praxis of the Hyperborean Mystique as a principle of the Psychosocial Strategy, we see the need to previously clarify the existing confusion around the two mentioned ideas.

For all these considerations, we insist to the **W** kameraden, addressees of this essay, that they procure a profound comprehension of the thesis of this section, since on this depends, to a great extent, the subsequent assimilation of what is exposed here and even the interpretation of the role that the **W** Order must play in Germany and in the world.

B. Thesis

Let us recall the last concept of *Section IV*. We have established a fact: the Mystique is a morphological structure container, the ontological content of which is a being called charisma. And charisma or the charismatic agent, as we saw, is the expression of the Paraclete or Holy Spirit, which, as well as God insofar as the Holy Spirit is God Himself, manifests itself on a plane absolutely transcendent to the immanent plane of matter. The Paraclete is therefore inexperiencible and inapprehensible on the physical plane, and if its expression, charisma, is perceptible for some men, it is only by virtue of the memory contained in the Minne. This means an individ-

ual experience, since the Minne is something “personal,” different from one person to another. The “charismatic bonding” of more than one man, several or many (it is the same thing), can only occur in the framework of a Mystique.

But this “charismatic bonding” between Viryas that is experienced in the framework of a Mystique is, as we saw, a synchronistic and acausal phenomenon, i.e., a phenomenon that *does not occur because* of interactions of fields of force (magnetic, electric, gravitational, etheric, astral, form-structuring, pranic, akashic, etc.), since this would be equivalent to admitting causal relationships in the phenomena of collective charisma between Viryas. However, the hypothesis of fields of force or collective magnetism is the most accepted, even dogmatically, in modern crowd psychology and the reason for this is that the mentioned fields seem to possess real existence and, in part, generate diverse phenomena of collective psychology. But said collective phenomena *caused* by fields of animal or human magnetism have nothing to do with the “charismatic bonding” manifested to men by virtue of a Mystique.

For the Hyperborean Wisdom, the fact of mass-men (*Viryas*) does not exist, not even in the middle of a crowd. Always, alone or together, near or far, the *Viryas* remain *one* in the mystery of the blood, and if any link exists between them, it is that of the *Catena Aurea*, the golden, synchronistic, non-causal cord of the Symbol of the Origin, which binds, outside the material determinism of the universe, the divine race of *Khristos LúCIFER*. Therefore, “charismatic bonding” is transcendent and individual, man by man, *Virya by Virya*, and if it involves a number of men in the framework of the Mystique, they should not in any way be considered a mass or crowd. However, the Hyperborean Wisdom accepts that in animals or animal-man (Paśu) force-field phenomena occur due to the genetic unity of all that exists within the space-time continuum in which the ordering action of Jehovah Satan, the Demiurge of matter, is manifested.

In Section VI we will give a synthetic vision of the Hyperborean cosmogony that will clarify this last concept.

The important thing is to now comprehend that as long as the masses or crowds are considered from the quantitative and causal point of view, subject to psychological phenomena of force or magnetic field, we are committing a gross error from the Hyperborean perspective and running an esoteric risk be-

cause the “collective forces” that act in the animal or animal-men populations (Paśu) are of a clear satanic or demonic order, technically termed in occultism as “archetypal projections in the astral light” or egregores, i.e., collective archetypes vitalized and “released” outside of man and outside of men, but with the capacity to act on men. This erroneous conception has taken such a rise in political and social sciences that, even in Germany, and what is worse even in the National Socialist Party, there were those who did not hyperboreally “see” the people as the group of *Viryas* that they are, but rather *saw*, synarchically, mass and crowd.

But without a Hyperborean vision there can be no comprehension of the *Führer’s* mission, which is to lead the people, as a single *Virya*, toward the collective mutation of the Kaly Yuga’s end, fulfilling *Khristos Lucifer’s* promise of liberation and transmuting the man into a superman, the *Virya* into an *immortal Siddha*, in a collective awakening, which, however, will be personal and secret because it will be given in the Seven Heavens and beyond Heaven, for each one.

The synarchic vision of the mass-man, on the other hand, offers an idea of a herd that can only lead to a collectivist conception of society and the state, such as occurs with socialists and Marxists or a liberal democracy in which the state, controlled by political oligarchies and economic mafias, is based on the suffragist masses, whose majorities exercise no real control over their historical destiny and are simply reduced to subjugated “classes.”

The Hyperborean vision leads us to the liberation from the causal order, to the elevation of man from the collective in which he is immersed and to his definitive individuation, reintegrating himself into the Self. It is the end of the Kaly Yuga or Dark Age.

The synarchic vision means continuing in the causal order, subject to the law of evolution and the guidelines of material progress on which Western civilization is founded. It signifies the ever greater immersion of the individual into the collective, marching history toward a mechanically complex future society in which man will disappear as such in a metaphysical atrophy of his ego, an indispensable objective in order to fulfill the aim of the synarchic vision that is the World Government. But in this super government the order of the hive will reign: a

gigantic world nest governed by an endogamous hierarchy, probably Hebraic. The world God?: Jehovah Satan.

The two ideas that we mentioned in the initial considerations are in relation to the two visions that we have just presented. The Hyperborean Mystique can only be understood with the Hyperborean vision. The crowd psychology that we will review below is the product of a synarchic vision of human society and history. But the Psychosocial Strategy demands the use of a “Mystique” in order to obtain the “charismatic bonding” between the Viryas, which will enable their conduction and control by the leader or Führer. Crowd psychology claims something similar by postulating that, in an “organized crowd,” a “collective consciousness” is formed that can be led and controlled by a leader. And this synarchic conception of the “collective consciousness” is the cause of the great confusion that the subject of the Mystique raises, which is almost impossible to grasp hyperboreally without discarding such force-field or collective-magnetism hypotheses.

We will then study where the confusion comes from and then confront both ideas and draw definitive conclusions.

C. *Demonstrations*

The main element of confusion is the concept of “collective” that crowd psychology uses, drawn, predictably, from the field of zoology. In effect, the “charismatic bonding” of the Mystique can be confused with collective phenomena, typical of animal populations, and even a crowd psychology has developed and a whole sociological school has arisen from the works of the Frenchman *Gustave Le Bon* and his disciples, which contributes to perpetuate this state of confusion.

To dispel this error we will now demonstrate the existing difference between the Hyperborean Mystique and the following synarchic definition of “organized crowd,” which psychology established from empirical observations:

“In the ordinary sense of the word, a crowd is a gathering of any number of individuals, whatever their nationality, profession, or sex, and whatever chance brings them together.

“From a psychological point of view, the expression crowd takes on a completely different meaning. Under certain circumstances, and only under certain circumstances, an agglomeration of men possesses new characteristics that are very different from those of the individuals making up the agglom-

eration. The conscious personality fades away, and the feelings and ideas of all the units are directed in the same direction. A collective soul is formed, transitory no doubt, but with very distinct characteristics. The collective then becomes what, for want of a better expression, I would call an organized crowd, or, if you prefer, a psychological crowd. It forms a single being, and is subject to the *law of the mental unity of crowds*.¹³⁰

Let us say, first of all, that this idea of the collective soul expounded by Le Bon is very ancient, being a remote antecedent of it: “genies that the ancients called the Skywatchers or the Eggrégores.”¹³¹ An egregore is a psychic entity capable of acting on a collectivity, animal or human, its existence being a reality accepted for millennia by countless cultures around the world. In the West, the concept in its erudite and operative version was the privilege of magicians and alchemists and it succumbed when they were wiped out by the Inquisition during the Middle Ages. Positivism after the Renaissance also disqualified the term in its profane version, making it disappear from everyday language. In spite of all this, the Synarchy and all its theosophical schools tend to use it in a more or less degraded and demonic sense. For example, while in Greece an egregore was a celestial divinity such as the spirit of a star, or a heavenly body, or simply a titan. In medieval Scholasticism they were equated with secondary causations,¹³² and for Jewish kabbalists they were the Anakim of the Bible. In this degradation of the term, we arrive at the egregore: “collective soul” or “astral entity” used by the Synarchy, as we can read in the translator’s note of an Argentine edition of Éliphas Lévi’s *The Great Arcanum, or Occultism Unveiled*:

“Eggregores. Astral form generated by a collectivity. Concerning the invisible chains and the formation of the collective being which occultism calls eggregores, G. Phaneg says:

130. *Psychologie des foules*, Gustave Le Bon, 1895; Ed. Félix Alcan, 9th edition, 1905; pp. 11-12

131. *Le grand Arcane ou l’Occultisme dévoilé*, Éliphas Lévi; “...génies que les anciens nommaient les veilleurs du ciel ou les Eggrégores.”

132. *Compendium of Saint Thomas’ Theology*, Vol. 1, Fr. E. O’Donnell, 1859; p. 207. “God is the primary cause, and all secondary causes with their effects depend on that infallible, eternal cause. The order subsisting in the universal cause is immutable and irrevocable; but He can change the order existing in secondary causes; for, as He could establish it in another form, so He can alter it, either in doing things which secondary causes could not be able to produce, or in suspending the exercise of the powers He had given them.”

‘Thought, will, and desire are forces as real, perhaps more so, than dynamite or electricity. Under their influence, astral matter, which is so plastic, compacts and takes shape. Numerous experiments prove this. If a few people gather in one place, emitting strong, identical vibrations and thoughts of the same nature, a real being will come to life and be animated by a force, good or bad, according to the type of thoughts emitted. At first weak and incapable of activity, ready to dissolve if abandoned, this collective being becomes more precise as the number of meetings increases; its form becomes clearer and clearer, and it acquires greater and greater scope for action. Just think of the terrible force that the egregore of a great religion must have had after 2,000 years. What power it will have to help its followers or punish them from time to time.

‘We can now understand that if the sorcerer is alone, and if the bewitched person is part of a chain of some kind (religion, mystical association, etc.), of a gathering of beings, in a word, with a powerful egregore in the unseen world, the evil adept will be wasting his time and effort. On the other hand, if the victim is isolated (which in our age of skepticism is unfortunately all too frequent) and if the sorcerer is affiliated to an occult association, the bewitched person is more or less lost, except, of course, for unforeseen circumstances.’¹³³

‘The egregore, having at its disposal the energy and the accumulated knowledge of the people who form it, will be stronger and more intelligent than any of the members in particular; it watches over and directs them, correcting and punishing them, when they try to deviate from the common lines.’¹³⁴

We have said that the egregore, a Greek word that means “watcher,” expresses a very ancient idea, and we have already seen that, in modern synarchic occultism, it has a specific meaning of an astral entity with a collective influence. However, we have yet to arrive at the true origin of the idea expressed by the word *egregore*, which must be sought in the kinship that this word has with *gregarious*, from which comes another idea, also ancient, that of a “gregarious spirit.”

133. “Étude sur l’envoûtement,” a summary of a lecture given by G. Phaneg at the Société d’Études Psychiques de Nancy. Published in *L’écho du merveilleux*, N°. 219, 1906; p. 74

134. *El Gran Arcano del Ocultismo Revelado*, Éliphas Lévi, Editorial Kier, 1977; p. 148

Now we are closer to the original idea and we must emphasize two things. First, that the “gregarious spirit” is the concept that *Gustave Le Bon* has reworked, stripping it of esotericism and disassociating it from the egregore, under the denomination of “collective soul” in his crowd psychology. Second, that the etymology of *gregarious* leads us to the Latin word *Grex*, which means flock, herd, pack, i.e., to animal populations. It is known that in the animal kingdom, to which man belongs from the biological point of view, some species manifest the tendency to live in a social order, this being concentrated mainly thanks to the possibility that the members of the considered animal species possess, to communicate with each other, i.e., to provoke and receive stimuli of different types among themselves. Given that animal societies range from simple groupings of members, associations for primary motives like the “security” that living together gives, the mutual stimulation of “easy” mating, the delousing, etc., to complex organizations like insect societies where a true division of labor is practiced on the basis of highly differentiated members of the species, it is not useful to approach the study of human societies by overlooking the innumerable references to animal collective behavior obtained by science from rigorous observations. We affirm this because since man (Pašu) is a higher study in the species scale of the animal kingdom, a substrate of primitive motivations easily comparable to those present in the behavior of other lower social species underlies its behavior as a social being.

This becomes evident with regard to the phenomenon of gregariousness that we are considering, the typical manifestations of which in animal behavior can thus invariably be detected in human behavior, it being commonplace to speak of gregariousness as the “tendency or inclination of certain animals to live in society with their congeners” and also as “gregarious army,” a tendency, for lack of their own ideas, to docilely follow the opinions of the majority.

It can be seen, then, that the same word, *gregariousness*, designates a phenomenon that is both animal and human.

In animal societies there are often “higher” phenomena of gregariousness that have resisted all attempts at rational interpretation. These are those that involve an instantaneous collective “response” to certain external stimuli perceived by one of the members of the flock (herd, flock, pack, school, shoal,

etc.) and that have a special relation to collective phenomena of human crowds of the type of collective psychosis or collective history.

These higher forms of gregariousness are those that in ancient times were justified by the existence of an *egregore*, a collective or group soul, which was directing the animal population. In the theories of "spiritual evolution" spread by the Synarchy through Theosophy, Rosicrucian Philosophy, Anthroposophy, Martinism, Freemasonry, etc., it is said that the animal kingdom evolves according to group plans, guided by *devas* or other nature spirits, so that effectively all the animals of a herd, for example, are a single spiritual entity or group soul. Man, in these theories, having evolved from the lower kingdoms, elemental, mineral, vegetable and animal, becomes "individualized," thus becoming a single spiritual entity. We will return to this theory in Section VI when synthetically studying the Hyperborean cosmogony.

Let us say for now that the "instinctive behavior" with which modern science attempts to justify the most incomprehensible phenomena of gregariousness, is not enough to justify the organic functioning of, for example, an anthill, of a beehive, where it seems more appropriate to speak of the "spirit of the anthill" than of the individual instinctive behavior of ants or bees.

Biologist J. D. Carthy says: "As a flock takes off, turns and wheels in the air, and lands again, it often seems as if the birds are no longer individuals but simply parts of a great machine." Further on he says: "Just as a flock of birds wheels and turns together so, too, does a shoal of fish. It is startling to see a shoal of herring suddenly change direction. The fish are swimming along in a certain direction at one moment; then, within a fraction of a second, they will all turn at a sharp angle to left or right, keeping in perfect formation."¹³⁵

For these and other similar phenomena of animal gregariousness, science has no satisfactory answers except to resort to the very ancient concept of the *egregore*. This is what *Louis Charpentier* does in a long page that can serve as a summary of all the above:

"An animal that is alone, solitary, is an individual with its own qualities, whatever they may be.

135. *Animal Behaviour*, John Dennis Carthy, 1965; p. 54

“When animals form hordes, herds, or clans, a phenomenon called ‘gregariousness’ occurs, which seems purely instinctive. A ‘herd’ or ‘horde’ or ‘clan’ entity is created, integrating each animal as a cell of this new entity. The herd reacts as a herd, not as isolated individuals. There is no longer animal fear, animal anger, but herd fear, herd anger. The herd instinct prevails over the individual instinct. Hindus call it ‘clan-soul,’ occultists call it ‘egregore.’ The word is more scholarly, but amounts to the same thing, and expresses the formation of the ‘clan’ entity.

“Now, and this phenomenon is constant and constantly observable, this ‘egregore,’ this ‘clan-soul’ is concentrated in one of the individuals in the herd: the one that we call the ‘leader.’ A herd always has its ‘leader.’ It seems to concentrate within itself the herd’s instinct, the herd’s thought; it originates the herd’s actions.

“The phenomenon is too constant not to respond to a biological law, and it seems clear that this gregariousness is created without each individual having the will to do so. The process is somewhat analogous to the laws of gravitation: a collection of particles creates a body with a unity, a center of gravity, and qualities different from those of its constituents. In the same way, the herd has a personality, a power other than that of its constituents. And the ‘leader’ has a personality different from that which it had as a solitary individual, and it loses this personality when it finds itself solitary.

“This gregarious instinct exists in both humans and animals, but with a few noticeable differences. It can act unconsciously, but it can also be created voluntarily, as was the case with the commoners of the Middle Ages and trade fraternities. It can also be seen, more fleetingly but no less convincingly, in sports teams. It is sometimes said that a rugby team, for example, is “in a state of grace” when all the extremely complex movements of the game are harmoniously coordinated, as if a superior intelligence were distributing the positions of the players in order to obtain the best possible efficiency for the ‘movement’ *to come*. This is when the ‘egregore’ has been formed, and each of the players (each of whom is, above all, intelligent enough to play his or her own game). In principle, this egregore ‘inhabits’ the captain. Or some other player who may not even be aware of it, but who ‘directs’ it without even having to give an order.

“To voluntarily succeed undoubtedly requires both a great deal of pride and a great deal of humility.

“Let us go a step further. Instead of an assembly of ordinary men, let us take a learned assembly who *want* to realize this egregore. This is, I believe, what we now call a ‘scientific team’; and we know that the results obtained by such teams are infinitely superior to those obtained by the sum of individuals taken separately (at least if the team has been fully realized).

“Let us go even further. Let us take an assembly of ‘magi’ who have gone beyond the stage of the scientist to reach that of the ‘*knower*,’ the connoisseur, the Initiate; in a word, of those who are, personally and consciously, in a ‘state of grace.’ Having surpassed all human vanity, they will be able to create an ‘egregore’ of a quality that, as with the herd, will exceed the sum of the qualities and possibilities of each participant; qualities and possibilities that will be set on one of them who will be, in the truest sense, ‘possessed’ by this spirit and who will, for the people, appear as a prophet, a saint, or a god.”¹³⁶

All that we have said so far is sufficient in order to demonstrate that when *Gustave Le Bon* says, in the paragraph quoted at the beginning of the section, that in an organized crowd a collective soul is formed, he is speaking of the ancient idea of the egregore. But if we still have any doubt, let us see what Le Bon means when he says that in an organized or psychological crowd, there is a “psychological law of the mental unity of crowds.” He elaborates this law as follows:

“Some of the psychological characteristics of crowds are common to isolated individuals; others, on the other hand, are absolutely special to them, and can only be found in groups. It is these special characteristics that we are going to study first, in order to show their importance.

“The most striking fact about a psychological crowd is this: whatever the individuals that make it up, however similar or dissimilar their lifestyle, occupations, character, or intelligence, by the very fact that they are transformed into a crowd, they possess a kind of collective soul that makes them feel, think, and act in a way quite different from the way each of them would feel, think, and act in isolation. There are ideas and feelings that only arise or are transformed into action in crowds of individuals. The psychological crowd is a provision-

136. *Les géants et le mystère des origines*, Louis Charpentier, 1969; pp. 138–140.

al being, made up of heterogeneous elements that have been welded together for an instant, in the same way that the cells that make up a living body come together to form a new being with characteristics that are very different from those possessed by each individual cell.”¹³⁷

We find that the very ancient idea of the egregore or collective soul and the more modern but related idea of gregariousness, are psychologized and presented in a “modern” or pseudo-scientific way in Le Bon’s thesis on crowd psychology.

Let us make a doctrinal clarification.

Our position is that the elements that empirical science presents in order to know and interpret the world should not be discarded, especially if this science enables us to extract some kind of technological praxis that contributes to improve the miserable condition of man, i.e., if it contributes a technical or cultural impulse to civilization. But when it is a matter of re-interpreting old ideas that have been much better formulated at one time by those who conceived them, but which, because of spurious interests, are presented as “new” by disguising them in scientific or academic language, we find ourselves in the presence of an authentic attack on culture or an obscurantist conspiracy. This is what occurs today with all this “Eastern philosophical current” that the Synarchy promotes through its countless schools and movements, with its “occultism” and its rationalist or atheistic “theosophical cosmogonies.” We do not intend, with this, to brand *Gustave Le Bon* a synarch agent, but what is certain is that his work reflects the “trend” of the time: he takes ancient ideas, of esoteric origin as we saw, and presents them as “new” or “original” in a psychological and rationalist language that “brings them closer” to the mediocre and amoral mentality of the “public” in the form of a “reference manual.”

In this attitude, whether self-interested or irresponsible, lies the danger of the “misuse” that could be made of knowledge that for millennia prudence advised to rightly hide from the “public,” whom today receives its “revelation.” Do not think that we are exaggerating, since the work of *Gustave Le Bon* and related schools have nourished numerous nuclei of synarchic research that have achieved such “beneficial” results for humanity as “psychological-action tactics,” “yellow-journalism

137. *Op. cit.*, Gustave Le Bon; pp. 14–15

techniques,” “collective hypnotic-suggestion techniques,” etc. An illustrative example of this is the so-called “communication sciences,” a euphemism that conceals the research of disciplines aimed at developing “message-penetration techniques” for purposes of sales and promotion, i.e., what we nowadays vulgarly call “advertising.” These “techniques” of social psychology have the declared aim of unconsciously “inducing” the man, the “receiver of the message,” to buy, vote, or perform acts that he would not do, surely left to his own free will.

Think of this synarchic vision of the de-spiritualized man, converted into a “consumer subject,” into a mass-man, psychologically “programmed” to “respond” to the messages of advertising or to the egregores that theosophist “occultism” dictates, and you will have an idea of what Satanism is. Think also of the Hyperborean vision of man, free and one in the search for the Self and God, but charismatically united with his race, in the mystery of the blood and immortality, and you will have an idea of what luciferic Christianity is. Surely from the reflection on both conceptions of man the reader will correctly conclude that the confrontation is inevitable and that he must even hasten it. And in this he will be right, for that is precisely the great lesson that the Führer has given us by posing total war against the Synarchy and having at his disposal a General Strategy, magical, Hyperborean, which guarantees the final success. Because in this war the Synarchy will be defeated and its defeat will mark the end of the Kaly Yuga.

Having made this clarification, let us say something in favor of Le Bon. In spite of the confusion that his work as a whole, an authentic synarchic manual, fosters for the Hyperborean vision, there is a notable merit in one part of it, which is his accurate affirmation, years before Dr. Jung expounded his theory of the “collective unconscious,” that the causes of the psychological phenomena of the crowds should be sought in the unconscious. In this respect we quote a revealing passage:

“It is easy to see how the individual in a crowd differs from the isolated individual; but it is less easy to discover the causes of this difference.

“To get a glimpse of these causes, we must first remember the observation of modern psychology: that it is not only in organic life, but also in the functioning of the intelligence, that unconscious phenomena play a preponderant role. The conscious life of the mind is only a small part of its unconscious

life. The most subtle analyst, the most penetrating observer, can only uncover a small number of the unconscious motives that drive it. Our conscious actions derive from an unconscious substratum created mainly by hereditary influences. This substratum contains the innumerable ancestral residues that constitute the soul of the race. Behind the avowed causes of our actions, there are undoubtedly secret causes that we do not admit to, but behind these secret causes there are even more secret ones, since we ourselves are unaware of them. Most of our daily actions are the result of hidden motives that escape us.

“It is mainly through the unconscious elements that form the soul of a race that all the individuals of that race resemble each other, and it is mainly through the conscious elements, the fruit of education, but above all of exceptional heredity, that they differ. Men who are the most dissimilar in intelligence have very similar instincts, passions, and feelings. In all matters of feeling: religion, politics, morality, affections, and antipathies, etc., the most eminent men rarely rise above the level of the most ordinary individuals. Between a great mathematician and his bootmaker there may be an intellectual gulf, but in terms of character the difference is usually nil or very slight.

“Yet it is precisely these general qualities of character, governed by the unconscious and possessed to roughly the same degree by most normal individuals of a race, that are pooled in crowds. In the collective soul, the intellectual aptitudes of individuals, and therefore their individuality, fade away. The heterogeneous drowns in the homogeneous, and unconscious qualities dominate.”¹³⁸

D. Conclusion: First Law of the Psychosocial Strategy.

The existence of two very ancient ideas, one expressed by the Hyperborean Mystique and the other by the crowd psychology of *Gustave Le Bon* and similar schools, has been clearly demonstrated. We have also stated that the first idea is fundamented in a way of thinking that we call “Hyperborean vision” and that the second idea, although it is part of a greater truth, serves as a fundament to another way of thinking called

138. *Op. cit.*, Gustave Le Bon; pp. 16–17

“synarchic vision” present in the crowd psychology and in its interpretation of social phenomena.

As our intention is not to make a dialectic between both ideas in order to obtain a *synthesis* of the conclusions, given that this rationalist attitude would be the worst method of “knowing” from the point of view of the Hyperborean Wisdom, we will present the conclusions in an affirmative way, and further ahead, in Section VI, we will support them doctrinally.

Let us first consider an affirmation: “The Hyperborean Mystique is not a *theory* that serves to *replace* crowd psychology.”

The two ideas must be considered as of a different order, not opposed or exclusive, but hierarchically linked to each other, in the ambit of that illusion that we call the real world. This means that the aforementioned ideas can be analogically related, just as we hierarchically link three classes of human beings: the animal-men or Paśus, the men or Viryas, and the supermen or Viryas, whom we know also as immortal Siddhas or divine Hyperboreans. We must consider, then, the hierarchical link between Siddhas, Viryas and Paśus, a question that requires the prior mastery of certain concepts of the Hyperborean Wisdom that we will try to summarize next in 20 commentaries:

- 1) Siddhas, Viryas, and Paśus, all three, possess a physical-biological body in the real and concrete ambit of the material universe. (We make this clarification because Siddhas possess the possibility of existing, also, without a physical biological body, outside of the material universe, a possibility that we are not interested in considering for the moment; on the other hand, when we speak of Viryas or Siddhas we refer to Hyperborean immortals, a meaning that should not be forgotten because the same Sanskrit words are used in India and Tibet for designating yogi or guru Adepts of the Synarchy.)
- 2) In a biological sense, at least, the three human types are analogous and the difference between them can be elementarily considered as follows: the Siddha possesses a center called *Vril* (this is what has sometimes been called *Spirit*, different from the *Soul*, although the former is not always meant when using the word *Spirit*).

- 3) The Virya has *lost* the Vril due to his blood impurity but he can recover it by experiencing the memory contained in the *Minne*.
- 4) The Paśu has never possessed the Vril and it is impossible for him to obtain it unless it manages to “mix its blood” with an immortal Siddha.
- 5) The Siddha is *pure* from the point of view of the blood, which means that, as a human being, he is a man awakened to the exterior reality of YHVH-Satan’s material universe.
- 6) The Siddha is master of *time* and if he remains *situated* in this material universe it is by his own will and only as long as *Khristos LúCIFer* also remains here, i.e., until the mystery of the Hyperborean redemption, also known as the *Return to the Golden Origin*, is fulfilled. But this *wait* does not *elapse*, for the possession of the Vril makes the Siddha immortal as a human being, not being subject at all to any evolutive law or to any determinism. The Vril implies living a *temporality of one’s own*, not interferable with the time of the phenomonic world in which the Viryas and the Paśus dwell. In *their time* the Siddhas live in collectively, synchronistically among themselves, and form an important part of the Hyperborean Race.
- 7) The Viryas can “know,” gnostically, of the Siddhas thanks to the *Minne*, but many of the Viryas, when passing the “Blood Memory” through the net of reason, in the impossibility of grasping the immortality of the Siddhas, have erroneously concluded that the latter *move circularly* in relation to them, both in space (i.e., in geography, because of the confusion originated when attempting to situate the Hyperborean center, *Thule*, in some place on the map, and to verify that it has been, or is, in many places at the same time) as well as in time (i.e., in history, due to the confusion originated by verifying that the interventions of the Siddhas, as well as the historical circumstances that motivated these interventions, like the Siddhas themselves, repeat themselves analogously and stubbornly insist on looking for a “cyclical law” to the becoming).

This erroneous perception has given rise to the idea of the eternal return, an idea that is applied in order to interpret both history and the individual destiny of man. But here

again there is a mistaken comprehension of time, which is also the cause of innumerable other confusions. Let us say for the moment that it is the blood of the Virya, his Minne, which is subject to a circular law of eternal return, but this is only a very rough image of a truth that we will try to see further ahead.

- 8) The Viryas are a *lost* part of the Hyperborean Race but it is possible that they can *return* to the bosom of it, individually or collectively (in the synchronistic meaning of this word), through the application of one of the seven secret ways.
- 9) Passing from Virya to Siddha does not consist in an overcoming or in a spiritual ascent, which is a moral idea based on the concept of “sin and fall” or on that of “evolution.” For the Hyperborean Wisdom there is neither “sin” nor “guilt,” but the *situation* of the Virya. The Virya has not fallen, *he has gone astray* (asleep if you will) by losing the Vril and his state is one of *confusion* rather than guilt.
- 10) As the blood’s gnostic content is the only resource that the Virya has for recovering the Vril and mutating into a Siddha, it is understood that the “impurity” of blood is his main obstacle. This impurity, of genetic origin, responsible for the gnostic confusion that signifies the ignorance of the Minne, is increased by incorporating Paśu blood into one’s own chromosomal inheritance in such a way that after a prolonged process of miscegenation, all possibility of mutation and return can be lost.
- 11) The Virya and the Paśu, like the Siddha, possess a physical-biological body, but subject to the spatio-temporal order of the material Universe. When the state of confusion is very great, the Virya differs little from the Paśu, since the linear *animal tendencies* of the latter predominate over the Hyperborean lineage represented by the blood Minne. But when, in the Virya, the Hyperborean inheritance predominates, the evolutive law that governs the material enchainment follows the circular form of the eternal return.
- 12) The Paśu is the basic strain of man. Its elementary qualitative definition is that of an “evolutive animal provided with a mechanism of rational-logical conduct located in the cerebrospinal system and of a *Soul* or mechanism of superior

- emotional conduct located, in part, in the nervous or bio-electrical system.”
- 13) The Paśu is absolutely collective, temporal, and mortal. It suffers an illusion of individual existence and believes to survive death, but in reality *it exists only* as a concrete representation of Archetypes created by *YHVH-Satan* and projected by His will into the material order of pantheistic manifestation. There, it is subject to a law of linear evolution that leads it to “progress” and ascend from “kingdom to kingdom” and from scale to scale, as the Synarchy teaches them, in a hallucinatory path that inexorably leads it, after enormous “sacrifices” and after a very long time, to discover God (*YHVH-Satan*) in “all things” and to worship Him. This illusion concludes with the phagocytation of the Paśu in the collective consciousness of the Demiurge, a nihilistic experience that the Paśus call *Nirvana* or *Samadhi*.
 - 14) The so-called *animal tendency of the Paśu* is, then, the law of linear evolution of the Demiurge’s pantheistic nature, temporally enchained with the will of *YHVH-Satan*, a question we will take up again in Section VI.
 - 15) Lastly, let us note that the biological-physical body of the Paśu is, literally, that of an anthropomorphic animal, only different from that of the Virya or Siddha in the circulatory-lymphatic system, but this difference is not verifiable by direct concrete observation but by means of one of the seven secret ways.
 - 16) The collective soul or egregore, a phenomenon characteristic of animal populations, is a collective psychic law *characteristic of Paśus or animal-men*.
 - 17) The Hyperborean Mystique is the formal law that bonds the Siddhas, i.e., the immortal supermen or divine Hyperboreans, whose purity signifies the possession of the *Vril*, the extra-universal nature or *uncreated Spirit*.
 - 18) The Virya is between the two. He partakes both of the divine nature, because of the Minne, and of the animal nature, because of what there is in him of the Paśu. But it is at this stage of the Kaly Yuga that the Paśu tendencies are seen to be expanded in all ambits of human activity because of the tremendous satanic impulse (i.e., Judaism) applied to civilization, an impulse that we see organically represented

in the Synarchy, everywhere we find the proliferation of crowds and psychological masses that fit Le Bon's patterns of collective conduct. And these masses, which it is up to us to classify and influence according to the principles of crowd psychology, *are not made up of mere Paśus*, but Viryas, in their *confusion*, collectively responding to the animal tendencies of the Paśu that there is in them.

- 19) It is for this reason (N° 18) that a hierarchical relationship must be considered in the two ideas set forth in this section, just as we stated at the beginning of this first conclusion, analogous to the hierarchical link between the Paśu, Virya, and Siddha.

We can now present this hierarchical relationship as a strategic category or *First Law of the Psychosocial Strategy*: “In the collective leading of the Viryas, the collective soul or egregore must *first* be controlled and *then*, only after this control has been obtained and secured, can the Hyperborean Mystique be applied.”

20) It should be kept in mind that, today, the Virya, any Virya, is confused of his divine nature, animalized, lost in the demonic world of the Paśu, or, perhaps, serving them and the Synarchy, in abject submission.

However, the Virya is the *first and last objective* of the Hyperborean Mystique. To them the whole effort of the national socialist revolution is directed, and for them Germany will fight its battle in the Cosmic War, which no one knows when it began or when it will end. For in the Total War is the heroic possibility of attaining purification and redemption for every Virya who *engages* in the conflict.

There being three classes of men, *Paśu, Virya, and Siddha*, we think it necessary to clarify that, for us, *the "Man" is the Virya*, the prototype of the Hyperborean hero, leaving the word "man" for naming the Paśu.

Therefore, when we say "man" it should read "Paśu," unless otherwise clarified. And, when we say "Virya" we refer to the prototype of the Hyperborean hero whose lineage all of us who fight on the side of Khristos LúCIFER participate in.

As for quantitative or generic words, like *race, humanity, people*, etc., we always interpret them according to this criterion: "race" is primarily a "race of Viryas." This word, race, can then exceed the framework of the classical ethnological racial classifications, because a race that "encompasses all Viryas" is a race based on the universal principle of the "common memory" of the Minne, which also means the "community of blood" that charismatically bonds the Viryas. The so-conceived "race of Viryas" is a community of Hyperborean heroes and monk-warriors, spiritual and universal, which can include, among its members, Viryas of all races of ethnic classification.

The word "humanity," which implies the whole of humankind, is normally used by the Synarchy from the point of view of the Paśu. Sentimentalism or cowardice, e.g., "virtues" of the Paśu, which are deeply repudiated by all Viryas, are thus considered "human." From such a synarchic concept of "humanity," the Virya will naturally turn out to be inhuman. We prudently try not to use the word "humanity" without first clarifying its meaning. Lastly, the word "people" and others like it should be used with a Hyperborean vision: people will be a "people of Viryas," etc.

We repeat what was said in commentary 18: this 1st strategic Law is circumstantial of the Kaly Yuga and has its origin in the confusion that the semi-divine Viryas suffer due to their blood impurity.

The hierarchical Law can also be stated as follows:

“When applying the Hyperborean Mystique, in the leading of Viryas, gregarious phenomena may come about according to the degree of their confusion. In these cases there is no sure possibility of charismatic bonding and mutation, therefore the Hyperborean Wisdom *first* recommends the control of the egregore by means of a known collective archetype adequate to the leading plans of the Psychosocial Strategy.”

Strictly speaking, this Law *does not imply two operations* as it seems at first sight, which would be: 1º) Control of the egregore. 2º) Application of the Hyperborean Mystique. Let us recall that the first, gregariousness, is a force-field phenomenon and that the second, charismatic bonding, is an individual and transcendent experience, only verifiable “collectively” in the synchrony of events, which means that both phenomena are as non-interferable to each other as to their conceptual essence; they are also two original ideas.

The decomposition of the “collective” fact in two realities hierarchically linked by the +a strategic Law was necessary only for the correct interpretation of the phenomena that we are considering and to act according to the Hyperborean Wisdom. In the instrumentation of the Hyperborean Mystique, that is in praxis, the Hyperborean Wisdom teaches that *a single operation suffices for achieving the double control of the Paśu and the Virya.*

This single operation will be explained in VII.

Section VI

Second Law of the Psychosocial Strategy or Quantum Law

A. Introduction



In Section V, by deducing the First Law, we have demonstrated that the crowd psychology of G. Le Bon and others, based on the possibility of influencing an egregore, is a synarchic science, suitable only to work on Pašus and “lost” Viryas. Notwithstanding this conclusion, the First Law affirms that the egregore must be controlled before applying the Hyperborean Mystique. It will be necessary, then, to master the science of controlling the Pašu despite this being a doctrine opposed to the Hyperborean Mystique. The strategic principle that “the final victory is more likely if we learn to know the enemy so well that we can foresee its slightest thoughts” must prevail.

Having saved the possible objection that could be made to the criterion used by me to approach the analysis of crowd psychology, we will say something with reference to this Second Law, which will be studied next.

Quantum Law, as is evident from its name, which is reminiscent of Max Planck’s theory of “quanta,” implies the definition of a psychophysics. For this, one must interpret the phenomena of “force fields,” the phenomena to which the Synarchy has devoted itself for centuries with reasonable results, of which its numerous “theosophical” schools give an account. It will seem to be a fair criterion, then, to take advantage of these “classic” studies of the Synarchy, always set forth in the control of the Pašu, and for us to use them in order to fulfill the First Law. Otherwise it would be necessary to develop a whole science that explains the reality of gregarious phenomena and which enables us to deduce control techniques from its own laws.

Strangely enough, the latter has been our criterion: a whole new science, more exact than any that the Synarchy can possess, has been developed from millenary concepts of the Hyperborean Wisdom and modern investigations carried out by the ⚡ so that no synarchic doctrine will be used by us, whether it comes from “East or West.” As the Führer has said: “The war against the dark forces, against the elementarwesen, is total. We will take nothing, not even on loan, from the enemy.”

It is because of this iron doctrinal position of the Thulegesellschaft that we reiterate to the ⚡ kameraden of Wewelsburg that they always renew their fight to the death against the synarchic, evolutionist, and falsely occultist culture. Nothing is necessary to take from them, having at our disposal the millenary and marvelous Hyperborean Wisdom.

B. *Two Assertions for the Analysis*

- a. "When the Virya is constituted in a 'charismatic collectivity,' i.e., when 'charismatic bonding' is established between him and his fellows in the mode of a Hyperborean Mystique, *he rises from the mere human level to the super-human or divine.*"
- b. "When man (Paśu and lost Virya) is constituted in a "psychological crowd," i.e., when he participates in a collective soul or egregore, he descends from the human to the animal level."

C. *The ⚡ Leader Demonstrates Assertion "a"*

Let us bear in mind a previous warning. From assertion "a" must be established a value judgment that will finally dissuade the kameraden from using, even by mistake, the degrading praxis of crowd psychology that the Synarchy uses and fosters. Whoever does not address the people (*Volk*) mystically, with a Hyperborean vision of the world, will inexorably fall prey to demonic egregores and will become part of the synarchic "plan"!

There are many ways to lead people, but only the Hyperborean Mystique guarantees their liberation from the evolutive and determinist law that governs the satanic world of matter. That is why the ⚡ has dedicated enormous efforts in the formation of an elite of charismatic leaders capable of acting according to the principles of the Hyperborean Wisdom. Let us say two words about this elite.

The "raw material," i.e., the Viryas, are initially recruited in the Ordensburg and selected as highly qualified elite elements for receiving the Hyperborean initiation at Wewelsburg. There, after a more rigorous selection, they are placed under the care of special instructors belonging to the penultimate circle of the Thulegesellschaft. The first step of their initiation is to "perceive the Minne," a marvel that is achieved after a great effort of purification. The "Blood Memory" makes them,

at last, mutable and they can thus receive the initiation. This experience, in itself, is indescribable, but which, nevertheless, produces a permanent and irreversible modification in the Virya, susceptible to being perceived by all, and we will refer to it. The Virya, after initiation, has transmuted his lower Paśu nature and is now an authentic Hyperborean hero or a “re-oriented Virya.” He is not yet a Siddha, but he will never yield to the animal tendencies of the Paśu. The initiation at Wewelsburg has brought him into metaphysical “contact” with Khristos LúCIFER and from this transcendent experience he will tend, in the world, to form a luciferic archetype, a solar hero or monk-warrior. He will be a “Christian knight,” in a much deeper and more mystical meaning than that which is usually given to these terms. Because this “coming into contact” is a mystical ecstasy in which the ⚡ kamerad achieves individuation (Self) and the consciousness of the Vril. From then on he is already a “charismatic leader” fit to serve the people, the Reich, and the Führer.

The psychological profile of this type of ⚡ Leader will certainly be considered as “not very human” and even “inhuman” but this is due to the great racial purity of the Viryas who form, as we already said, a luciferic archetype, an imitation of Khristos LúCIFER. In fact, the ⚡ Leader already appears as “strange” and “cruel” in the judgment of profane observers. But these profane ones, degraded and softened by the decadent customs of the Kaly Yuga, cannot appreciate the beauty and *Apollonian* intrepidity of the ⚡ Leader. For that, they should possess the eye of Pindar.

In reality, the racial purity of the ⚡ Leader, without the animal tendencies of the Paśu, makes him a superhuman being, a true prototype of the liberated and transmuted Virya. Thus, an objective judgment on the virtues of the ⚡ Leader can only be made on the basis of a “Hyperborean vision.”

For our part, here is the opinion: we have seen the ⚡ Leader act charismatically on the crowd. His voice was sounding energetic and irresistible, awakening in the listeners the reminiscence of that common memory that unites us all in the eternal return. And we have seen the Viryas immediately obey the ⚡ Leader, moved by the charismatic bonding that they were intimately perceiving. We thus proved that the ⚡ Leader awakened, in the Viryas, the “knowledge of the hierarchy’s fact,” with the result that they, each one of them, knew that the ⚡

Leader was superior, before obeying, and, what is important, they were not participating in any gregarious impulse.

The ⚡ Leader that we have evoked conducts himself according to the laws of Psychosocial Strategy. The First Law says that, in leading crowds, the egregore must *first* be controlled and *then* the Hyperborean Mystique must be applied. Therefore, it is necessary to undertake a systematic study of the phenomenon of gregariousness in order to understand how the ⚡ Leader controls the egregore.

D. Research of the Ahnenerbe Institute Regarding Assertion “b”

Assertion “b” has been rigorously verified through investigations carried out by circles of experts of the Ahnenerbe Institute. These investigations, which have already been going on for 7 years, could not be presented here because of their length, thematic variety, and methodological complexity, but we can cite some experiments that will highlight what has already been said.

First of all, it is worth mentioning the investigations performed in early times for verifying the gregarious phenomenon of the “collective soul.” For this purpose, among others, measurements of the main *human biorhythms* were carried out on different kinds of crowds. The sampling was carried out by considering the classification made by G. Le Bon.

A. Heterogeneous Crowds	<ol style="list-style-type: none"> 1. <i>Anonymous</i>. Like, for example, street crowds. 2. <i>Not Anonymous</i>. Juries, parliamentary assemblies, etc.
B. Homogeneous Crowds	<ol style="list-style-type: none"> 1. <i>Sects</i>: Political, religious, etc. 2. <i>Castes</i>: Military, priests, workers, etc. 3. <i>Classes</i>: Bourgeoisie, Peasant, etc.

The results of the investigations demonstrated conclusively that when the gregarious phenomenon takes place, *individual biorhythms* are altered and a *collective biorhythm* appears, corresponding to the collective soul of the crowd. In these cases it occurs that the cardiac or respiratory rhythms of all participants of the egregore *are connected* or synchronized, among other things, and the results are to a certain extent striking when seeing enormous multitudes shaking cadencedly in their uniform breathing.

But this is not all: other bioelectrical rhythms of the brain also tend to synchronize, as has been proven, so it can be stated without a doubt that gregariousness constitutes a typical “force-field” phenomenon, which tends to standardize all participants by subjecting them to collective laws.

These results can be completed by considering other investigations carried out in order to determine the degree of “sensitivity” that a collective soul or egregore presents.

This was the second major step in the investigations on collective conduct, for once the existence of the “collective soul” had been proved, the question arose: how does a psychological crowd react to different stimuli?

Of the multiple experiments conceived to impress the collective entity and test its capacity to react, perhaps the most illustrative for this commentary are those carried out in relation to the transmission of crowd-control instructions given by “professional agitators” totally unrelated to the ~~HH~~ or any official institution.

It is known that an agitator exerts a particular suggestion on crowds by leading them to blindly obey his instructions. On the basis of this fact, professional agitators were introduced into certain crowds, submitted to observation by scientists of the Ahnenerbe Institute, verifying that in the execution of commanding voices or in the chanting of slogans there was an *instantaneous and simultaneous* reaction in all the members. That is to say that the acoustic stimulus was provoking an instantaneous reaction in all the members, *even in those who had not heard the slogan* because they were too far away from the agitator. Something similar to the gregarious phenomena that occur in herds or flocks of animals at the complete turning of a shoal of fish, already mentioned.

These experiments have allowed us to intimately grasp the gregarious phenomena and the psychology of agitators or

supposed crowd “leaders,” which in reality are not such because all agitators and crowds respond to unconscious causes. The crowds follow a leader or agitator and the latter follows an “idea” that has absorbed him, that is to say, an archetype. This is what G. Le Bon had also ascertained, for he wrote:

“At first, the leader was more often than not a follower. He himself has been hypnotized by the idea of which he then becomes the apostle. It [the *egregore*, we say] has invaded him to the point where everything outside it disappears, and any contrary opinion seems to him error and superstition.”¹³⁹

We suggest rereading commentaries 16, 17, 18, and 19, since it is useful to keep in mind, in the following, the concepts expressed therein.

E. *Second Law of the Psychosocial Strategy or Quantum Law*

We have mentioned investigations that have yielded quantitative information on “synchronized biorhythms” in psychological crowds. We will now deal with the qualitative aspects of the phenomenon. It is worth knowing, first of all, that these synchronized biorhythms (presumably the synchronization occurs when the *egregore* or collective soul is constituted) *do not remain constant*, i.e., they do not keep the rhythm but vary during the phenomenon.

The qualitative analysis of these variations of rhythm, verified in experiments of various kinds, has made it possible to establish the existence of certain extremely *stable* and repetitive *states* in psychological crowds. For example, in the *same* psychological crowd, the parameters measured on *different* occasions, corresponding to *identical stimuli*, always turned out to be the same and repetitive. This and other examples enable us to arrive at the following conclusion: “In every psychological crowd, agglutinated by a collective-soul or *egregore* phenomenon, the collective conduct is led according to a causal relationship that we call the Quantum Law of Psychological Crowds.”

This law is developed in five “phases” that correspond to the five most stable “states” of the psychological crowd. Its formulation for the use of the Psychosocial Strategy is the following:

139. *Op. cit.*, Gustave Le Bon; p. 106

Quantum Law of Crowds

1st Phase - Genesis of the Egregore (Mahapaśu).

Verification: A synchronization of biorhythms is measured and verified.

2nd Phase - Human Level of the Egregore (Paśu).

Verification: The measured biorhythms correspond to human physiology.

3rd Phase - Subhuman Level of the Egregore (Shedim).

Verification: The measured biorhythms do not correspond to human physiology.

4th Phase - Avalanche Effect.

Verification: When discharging the energy it is verified that the collective conduct follows a pattern of animal conduct. The Avalanche is analogous to the “stampede” in animal populations.

5th Phase - Extinction of the Egregore or Closure.

Verification: Decomposition of the gregarious conduct; de-concentration of the multitude; recovery of the individual conduct; etc. In all cases the absence of synchronized biorhythms is verified.

The quantum law begins to govern when the egregore is “born”: this “genesis of the egregore” is the first phase. From the 1st phase, the two immediately subsequent phases, 2nd and 3rd, can develop and the closure, 5th phase, can ensue “after” arriving at any of them, 1st, 2nd, or 3rd phase. But if the 4th phase, Avalanche, is reached, it is not possible to provoke the closure without first producing an effect of *irreversible discharge of psychic energy*, in the course of which the crowd remains “uncontrolled,” exterior to the egregore.

To reach the closure of the egregore’s phenomenon or extinction after any of the phases, 1st, 2nd, 3rd, or 4th, a complete “change of state,” corresponding to such a phase, must occur in the crowd.

The passing from one state to another, from an “energetic” point of view, that is, from the psychophysical energy, whatever it is, is operated as a “change of level” or “jump,” similar to that which occurs in the “changes of state” of matter studied in

Thermodynamics. For example, water, from its solid “state” (ice) jumps at 0 °C, to its liquid “state,” and from this it jumps to its gaseous state (vapor) at 100 °C. But as long as the temperature does not arrive at the “set point,” e.g., the boiling point at 100 °C, the change of state does not take place, not even at 99.9 °C; but as soon as it reaches this temperature, matter changes state abruptly, in a jump. On the other hand, as can be seen in the graphic of the variation of water temperature with time, during the “change of state,” the temperature *remains constant* (segments \overline{AB} and \overline{CD}).¹⁴⁰ That is, e.g., the temperature remains constant at the “set point” of 100 °C until complete evaporation of the water.

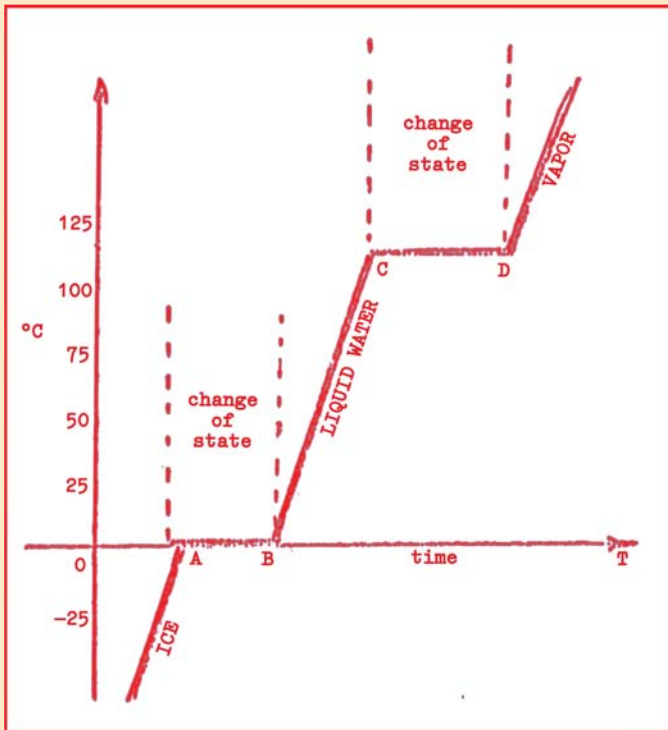

The change of psychological state occurs in an analogous way, measured in its energetic parameters as we will see, which expresses the phase change of the Second Law. This characteristic of the level jump and the fact that the “energy” seems to be emitted or transmitted by quanta (from the Latin

140. The temperature remains constant during the change of state from solid to liquid (while ice melts) and also from liquid to vapor (while water boils into steam).

quantum, “quantity”) of energy or particles called UEVACs, has been the reason why we called the Second Law “Quantum Law of Crowds.”

We must emphasize that the 1st, 2nd, and 3rd phases of the quantum law correspond to transformations in which an “*energy accumulation*” takes place in the egregore, so we call these phases “positive.” The 4th and 5th phases correspond to “*energy discharge*” of the egregore and are considered “negative.” But, it will be said, “What do we mean by *energy accumulation* and *energy discharge*?” It is necessary, before continuing with the interpretation of the Second Law, to respond to these and other questions with some concepts of psychophysics.

F. *Elements of Psychophysics*

From the corresponding investigations it has been arrived at the conviction that the phenomena of gregariousness, typical of the Paśu and the lost Virya, must be interpreted in the framework of *psychophysics*. This conviction is mainly fundamented in the fact that the phenomena of gregariousness, as well as other *paranormal* psychic phenomena, present all the characteristics of natural phenomena that are usually defined on the basis of the physicomathematical *field and energy* concepts.

Therefore, the problem lies in knowing what this “psychophysical field” is like and what the “psychophysical energy” is.

With the aim of advancing in these investigations, the ⚡, through the Ahnenerbe Institute, has developed the theory that we apply in this dissertation on the Psychosocial Strategy.

In principle, we must accept the existence of a great field called *psychosphere* that surrounds the Earth and interpenetrates it totally. Strictly speaking, it must be said that the Earth, as well as its atmosphere and all related substances, are “within” the psychosphere, which exists apriori to this ordering of matter that we call “the World.”

The psychosphere is, according to the Hyperborean Wisdom, one of the “bodies” or “veils” of the Demiurge Jehovah Satan and its metaphysical nature is discussed in Section VIII. We also note that the psychosphere has a relationship with the traditional pantheistic concepts of “world soul” (*anima mundi*), etc.

It is in the “great field” of the psychosphere that the “psychophysical” field of gregarious or collective psychological phenomena must be situated.

As far as “energy” is concerned, a distinction should be made between “psychic energy” and “psychophysical energy.” The term “psychic energy” should be kept for individual psychic processes and elaborations, especially unconscious ones, and can be assimilated to the traditional concept of *libido*. The “psychophysical energy” is that which intervenes in the collective phenomena of gregariousness that we are studying and in many others, including *every action of the psychosphere on the individual*. The psychophysical energy, which intervenes in every reciprocal interaction between man and the psychosphere, is of a quantum nature and is called “quantum of psychophysical energy” or UEVAC or the *unit of psychophysical energy*.

UEVACs totally fill the psychosphere (which means *all space*) and possess, each one of them, a *non-coordinable point* in the current four-dimensional space. These non-coordinable points, which are at the *center* of each UEVAC, possess the unusual property of being indiscernible, i.e., the same; with absolute sameness. The absolute identicalness between two things contradicts Leibniz’s *Principium Identitatis Indiscernibilium*, the principle of the identity of indiscernibles. This philosophy starts from the erroneous belief that the material world has been created by God and by virtue of His perfection, *Dei Perfectio*, no two things could be the same. According to Leibniz, God would not have created the same thing twice.

The Hyperborean Wisdom, on the contrary, affirms that the material world has been “ordered” by the Demiurge Jehovah Satan and that the principle of the “*Siddha*’s absolute individuality outside of matter,” such as we conceive it, demands, *by opposition*, the violation of Leibniz’s “principi-um.” This question and the *paradoxical* nature of the UEVAC will be dealt with in Section VIII. In the meantime, we will continue with the psychophysical concept of the UEVAC.

We were saying that the UEVAC possesses an indiscernible point. This means that although the UEVACs occupy different places in space, they all have a common point for which there is no distance between one and another because they are all the same point (paradox). This property allows us to explain numerous paranormal phenomena such as, e.g., the “instan-

taneous transmission” of messages in *telepathy* because in reality there is no “transit time” of the information, since *there is no distance between one point and another, no matter how distant they are* (paradox).

Attached is an appendix with all the UEVAC theory for anyone who wishes to delve deeper into this complex subject.

Returning to the previously posed question, it is useful to divide it into two questions, to which we will respond separately.

1) What is meant in psychophysics by: *energy accumulation in the egregore?*

In the 1st, 2nd, and 3rd phases of the Second Law the crowd yields psychophysical energy to the psychosphere, which is “accumulated” in a collective entity, egregore, according to a law of crystalline symmetry (from which are derived the laws of common crystallography) so that from the point of view of psychophysics the egregore is rigorously a *psychocrystal*. This law, as it occurs with the associations of macromolecules in a common crystal, says that “1 + 1 = 1 greater” or that “a unit of energy added to a unit of energy is equal to a unit of greater energy.”

The egregore is then a “capacitor,” which is charged with psychophysical energy, in which all the members of the crowd participate. However, the egregore, upon forming part of the psychosphere, follows an “archetypal order” that determines its nature, its form, its behavior pattern, etc. We will try to explain it. Dr. C. G. Jung affirms that gods and myths are “archetypal representations”: “the archetype as such is a hypothetical and irrepresentable model, something like the ‘pattern of behavior’ in biology.”¹⁴¹

Archetypes would be common to all humanity and their genetic nature would make them transmissible by inheritance, i.e., Analytical Psychology confines us to the field of biology with this hereditary “individual collective archetype.”

In using the concept of the psychosphere, on the other hand, let us consider an archetypal plane exterior to man, but common to all (collective) by the properties of the UEVAC energy, where underlie the Archetypes of existing things in the

141. “Archetypes of the Collective Unconscious,” *Collected Works*, Vol. 9, C. G. Jung; p. 5

world. We thus distinguish between “Archetypes,” of the psychosphere, and “archetypes,” personal.

Archetypes are the key to the “creation” of Jehovah Satan, that is to say, to the “ordering of the material chaos” that the Demiurge carried out when “giving birth” to the sensible world. They are equivalent to “ideas” of the Demiurge, which “materialize” through the UEVAC energy unit and the irresistible force of His Will, which He calls the Time of the World. We will return to this concept in Section VIII.

Archetypes of the psychosphere are the “supporting qualities” of existing things, the collective archetypes of the unconscious being merely the human correspondences of the former. Dr. C. G. Jung called these external Archetypes, *psychoïd*.

Because of these properties of the psychosphere we were saying that the egregore “behaves as a capacitor, accumulating psychophysical energy from the crowd” but “follows an archetypal order exterior to the crowd, which determines its morphology, pattern of behavior, etc.” It is that, in these cases, the egregore not only “responds to the form” of the Archetype, but consubstantiates with it, giving it UEVAC substance and vivifying it. The egregore, thus constituted, is “independent” of the individual archetypes of the crowd and behaves as a dominant Archetype of the psychosphere. This property of acquiring “life independent of the individuals who make up the crowd is what explains the “change of conduct” that is observed in the crowds when an egregore acts upon them.

It is understood in this way because it has been an ancient problem, but always current and typical of leaders and drivers of peoples; how to precede in order to some way control the collective soul or egregore of the multitudes. And it is also understood that in most cases the egregore of the people is so powerful that when it becomes “independent,” like the dominant Archetype, it provokes “the appearance of a leader, or chief,” as occurs in animal populations. This “chief,” a faithful expression of the egregore or its extension, assumes power by way of collective “recognition” without anyone being able to prevent it.

We can affirm that the means of “operating” on the Archetypes of the psychosphere exists, proof of which is the Psychosocial Strategy, and that, in fact, this operation has been going on since ancient times. But since the applied “techniques” were belonging to the domain of priests or initiates

and were secret, the modern inability to interpret the vestiges that we possess of such techniques has generally led to classify them under the dubious moniker of “magic” or “ritual magic.”

For our part, the path followed in order to arrive at such a knowledge will be the following: the First Law establishes that it is necessary to first control the egregore and then apply the Hyperborean Mystique. The interpretation of the Second Law will tell us how to do it.

2) What is meant in psychophysics by: *discharge of the egregore's energy?*

We already know what “accumulating energy” means in the 1st, 2nd, and 3rd positive phases of the Second Law; we will now study the “energy discharge” of the 4th and 5th negative phases.

We have seen that the psychophysical energy accumulates in the Archetype since the egregore begins, 1st phase, until the discharge takes place in the 4th phase, called “avalanche.” We must now clarify that this “avalanche” cannot come about if the 3rd phase has not been previously reached, an inescapable condition of the Quantum Law.

That is to say that although it is possible to “extinguish” the phenomenon after the 1st, 2nd, or 3rd phase through the closure of the 5th phase, in order to produce the “avalanche” (4th phase) it is necessary to have previously arrived at the 3rd phase. But we also said that the 4th and 5th phases were of “discharge” and we call them “negative.” Then why can one not pass, e.g., from the 2nd phase to the avalanche of the 4th phase, and why one can pass from the 2nd phase to the closing of the 5th phase, being that both are phases of energy discharge? We leave the question momentarily raised in order to point out some elements of judgment.

In the next section we will study the Paśu crowd agitator and the ⚡ leader, a Hyperborean leader of Viryas. From this we will also advance a concept that will make clear the importance of this Second Law for the Psychosocial Strategy: it must be kept in mind that “the 4th phase is the *most precious objective of the crowd agitator*. Why? Because it signifies, in practice, the *directed mobilization* of the crowd toward the attainment of an aim.”

Having emphasized the importance of this 4th phase, let us say that its main characteristic lies in the “short time” of the

event. Just as the 1st phase, the “genesis of the egregore,” is “almost instantaneous,” the 4th phase, “avalanche,” is even faster.

On the other hand, the 2nd and 3rd phases are progressive and slow, and the 5th phase is the slowest of all, and it can happen that the total breaking up of the crowd is reached and yet the effect of the egregore persists. The gregarious phenomenon can subsist even when the members of the crowd are very “distanced,” and, as we will see, there are cases in which the extinction never definitively occurs.

We will now respond to the pending question but we will do so with a provisional answer because a complete comprehension of the “discharge of energy in the 4th phase” will only be achieved after studying the next sections. The explanation of why it is necessary to previously reach the 3rd phase for the avalanche discharge of the 4th phase to occur is the following: “When a crowd forms a collective soul or egregore, 1st phase, it accumulates psychophysical energy in a mutual exchange with all members. This accumulated energy is ‘growing’ as the crowd goes through the 2nd and 3rd phases. If the accumulated energy is sufficient, and only if it is *sufficient*, a threshold is reached that allows the change of phase from the 3rd to the 4th and the avalanche. If the energy is *insufficient*, the *threshold* is not reached and the avalanche of the 4th phase does not occur, although the closure, 5th phase, and the extinction of the egregore may be obtained.”

This inflexible aspect of the Second Law can be better understood if we take into account that the avalanche of energy obtained in the 4th phase is a residue in the Paśu of a phenomenon typical of animal populations known as a *stampede*. Justly, the 3rd phase must be reached *without fail* because in it the egregore vitalizes a zoomorphic or anthropozoomorphic Archetype, *Shedim*, the behavior pattern of which is subhuman or animal and of which biorhythms, measured in the crowd, present a *regressive shift*. In these conditions it will come about that a certain *stimulus* provokes a *reaction* in the crowd corresponding to the *stampede* of animal herds; this will be the “avalanche” discharge of the 4th phase.

All these explanations about the significance of the Second Law in its different phases will be better understood by utilizing an *analogical* model that enables a symbolic “visualization” of the phenomenon. This is what we will do in Section VII by means of a graphic analysis of the Second Law.

Section VII

Graphical Study of the Second Law



In order to graphically represent the Second Law, we have thought it useful to use a system of orthogonal Cartesian coordinates. But since here we are interested in the *qualitative aspect* of the gregarious phenomenon, we have chosen to suppress any quantitative reference to the figures and values obtained in the measurements and to use an *analogical quadrant*. This quadrant will enable us to make analogical representations of the Second Law that are very evident and suitable for comprehending our expositions.

A. The Analogical Quadrant

On the x-axis we have conventionally represented time (T). This “time” is to be understood as the “collective time” or time of the world, i.e., that which is measured by the clocks of the crowd’s members.

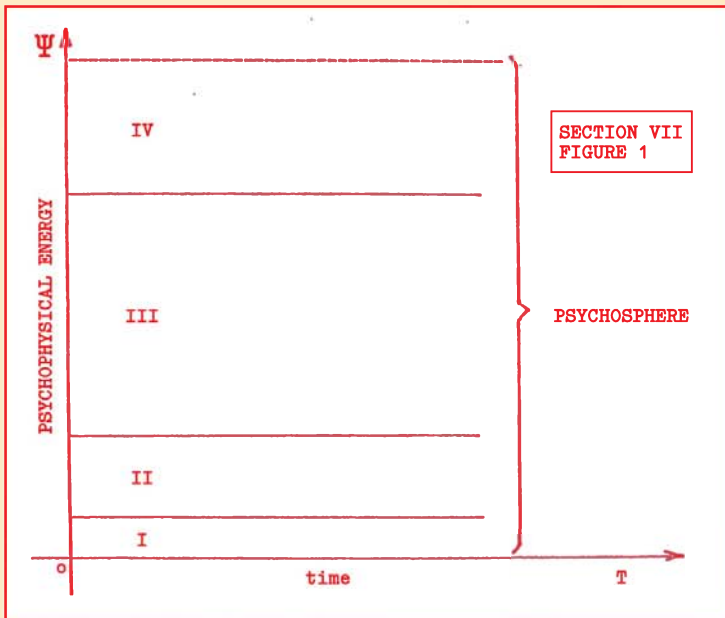

The y-axis of ordinates will enable us to assess the levels of psychophysical energy that the collective soul or egregore reaches and will be called the Ψ (Psi) axis with the symbol of the UEVAC energy unit.

We have indicated, with parallel lines, certain set levels of energy that exist in the psychosphere, but keep in mind that these are analogical representations. See Figure 1.

We distinguish four “zones” or “geometric places” in the quadrant, marked I, II, III, and IV, which constitute four “planes” of the psychosphere. Separating each zone is a straight line that represents a *set level* of energy or “level of the plane.” Let us attentively observe Figure 2. The first level, I, is analogous to the individual conscious of the Paśu or lost Virya.

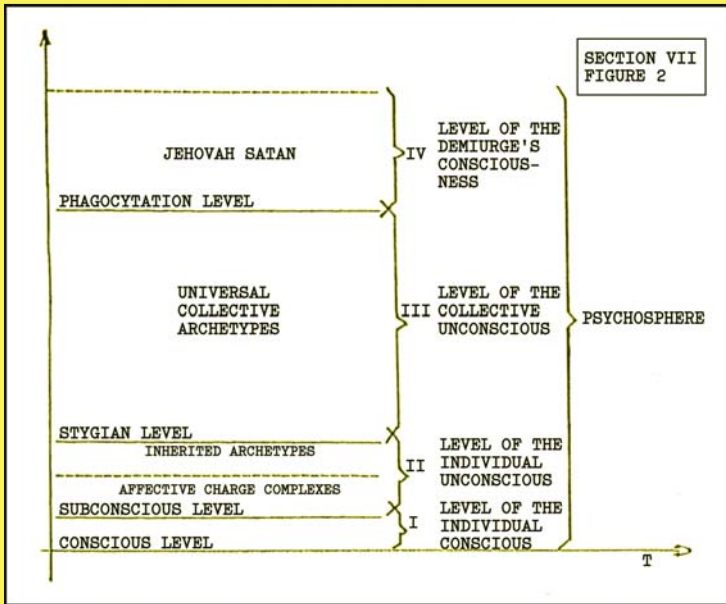

The second level, II, corresponds to the individual unconscious of the Paśu or lost Virya. It can be observed in Figure 2 that this second level is divided by a dotted line. This line divides the individual unconscious into two zones, one “closer” to the consciousness, called the personal unconscious, and the other, analogically “deeper,” which corresponds to the individual collective unconscious, i.e., to the set of inherited archetypes and their psychic “place.”

The third level, III, symbolizes that part of the psychosphere that we call the *universal collective unconscious*, i.e., a psychic plane that is *common* to all men because it is superimposed on the stygian line to the individual unconscious and allows the “mutual participation” between the two planes. Although the psychosphere interpenetrates all that exists, it is only through

this third level that the psychic, unconscious “contact” between the Demiurge and the Paśu takes place. This third level is the seat of the psychosphere’s Archetypes (also of the “collective memory,” as we will see) and naturally, where *egregores dwell*.

The fourth level, IV, is part, just a part, in order to respect the analogy in the quadrant, of the level of the Demiurge’s consciousness. For Paśus, it is the plane of “God,” so the perception of this level of energy is what is usually called *Nirvana*. We do not think it necessary to warn of the danger of bringing oneself into “contact” with level IV, the number of *Jehovah Satan*, because when crossing the level, *phagocytation* occurs, which is, in practice, a formidable *suction* of *psychic energy* (*psychic not psychophysical*) of the imprudent Paśu.

Between levels I and II, on the level line, there is a marked “dark zone,” α (alpha) on the Ψ axis. This zone resembles the interpenetration that the two individual planes, conscious and unconscious, present at the border (α). It is a mixed zone called subconscious, the first stage of the “ego” during sleep.

Between levels II and III, on the level line, there is another dark zone, slightly greater than α , marked as “ β ” (beta) on the Ψ axis. This zone symbolizes the interpenetration that the two unconscious planes, the individual and the collective, present in the Paśu. It is when *crossing* the dark zone “ β ” that the parapsychic phenomena of precognition, telepathy, etc., occur. It is also by crossing β that the egregore or collective soul operates.

Between levels III and IV, on the level line, there is a dark zone marked as γ (gamma) on the Ψ axis. It is the zone of phagocytation, whereby the Demiurge is re-fed with His own creation.

B. Graphical Representation of the Second Law

Let us start with the 1st phase: “genesis of the egregore.” See Figure 3.

We verify that the phenomenon starts from the subconscious level (α) and in a very short time (t_1) the egregore is formed when the Ψ_1 energy level reaches a stable “state.” Thus, the first phase of the quantum law is fulfilled, verifying that, as long as a change of state is not begun, the energy level remains stable in time.

The Ψ_1 state of the egregore is called Mahapaśu because in it, it presents a pattern of conduct “superior” (more “evolved”)

to that of the Paśu as a consequence of “activating” the Universal Archetype of the Paśu.

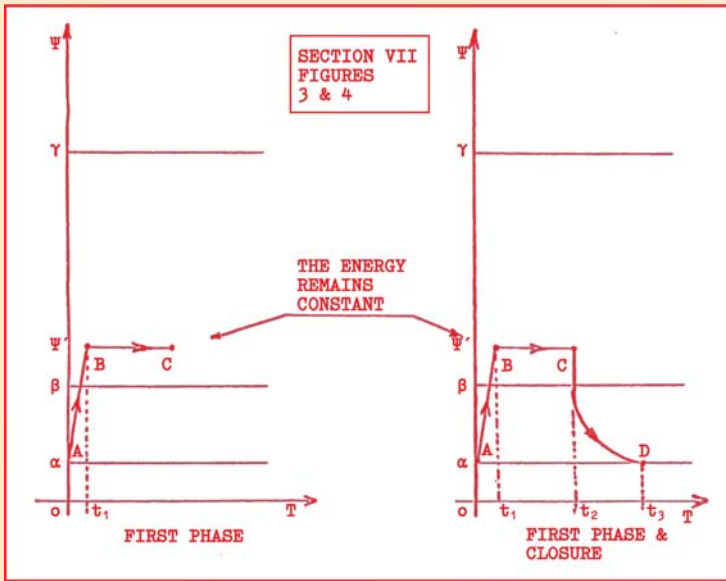

As “the human” is our standard of comparison, we must agree that this state is the most “elevated” that an egregore can reach, since it is the closest or most immediate to the human level. And this really is so because in the following phases the egregore descends in the archetypal hierarchy (evolutionary regression) until becoming an animal entity.

If in the representation of the first phase, Figure 3, when the crowd has reached the Ψ_1 state, we provoke the extinction of the egregore by means of the 5th phase of closure, Figure 4, we find that the discharge is slow, almost as long as the time that the Mahapaśu state lasted. The extinction is complete when the energy of the psychological crowd reaches the α level of individual consciousness, or subconsciousness, at which time the members “regain” the personal control that was in the egregore’s power.

Before continuing with the study of the 2nd phase, let us define the lines of the graph. Each line \bar{AB} , \bar{BC} , \bar{CD} represents a continuous variation of energy associated with a change of state and so each one of them is called a “transformation”; the arrow indicates the direction of the transformation.

In the mathematical analysis of functions it is said that if when increasing the abscissa (T) the value of the ordinate (Ψ)

increases, the function is *increasing*, and that when increasing the abscissa (T) the value of the ordinate decreases, the function is *decreasing*. Therefore, the \overline{AB} transformation is “increasing,” the \overline{BC} transformation is “constant,” and the \overline{CD} transformation is “decreasing.” The slope, an expression of the “rate of change,” is the derivative $\frac{d\Psi_i}{dT}$, and its sign indicates whether the function is increasing or decreasing.

That is why, because in the increasing functions the slope is positive and in the decreasing ones the slope is negative, we call the 1st, 2nd, and 3rd phases of the law positive and the 4th and 5th phases negative, as we will see.

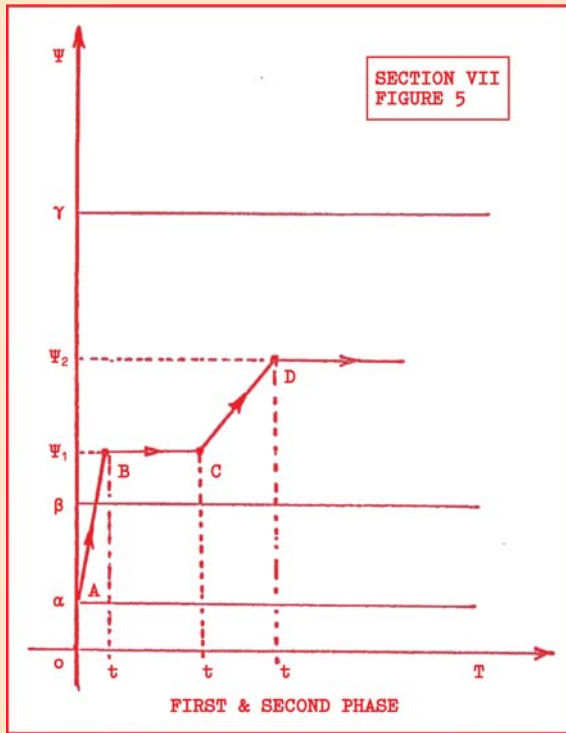

Let us consider the 2nd phase of the law. The egregore reaches the human state (Paśu) by slowly ascending the level in the 2nd phase. See Figure 5. Upon reaching the level the egregore retains the human characteristics of the Paśu. This state is extremely stable, perhaps the most stable of all and for such a reason it is somewhat difficult for the change of state to the 3rd phase of the law to occur. When the crowd reaches the second stable phase the agitators usually say that it is “tough”

or “weak,” alluding to the difficulty or ease of altering the very stable second state. From the Ψ_2 level onward, closure or change to the 3rd phase may occur. The extinction of the egregore or closure is depicted in Figure 6.

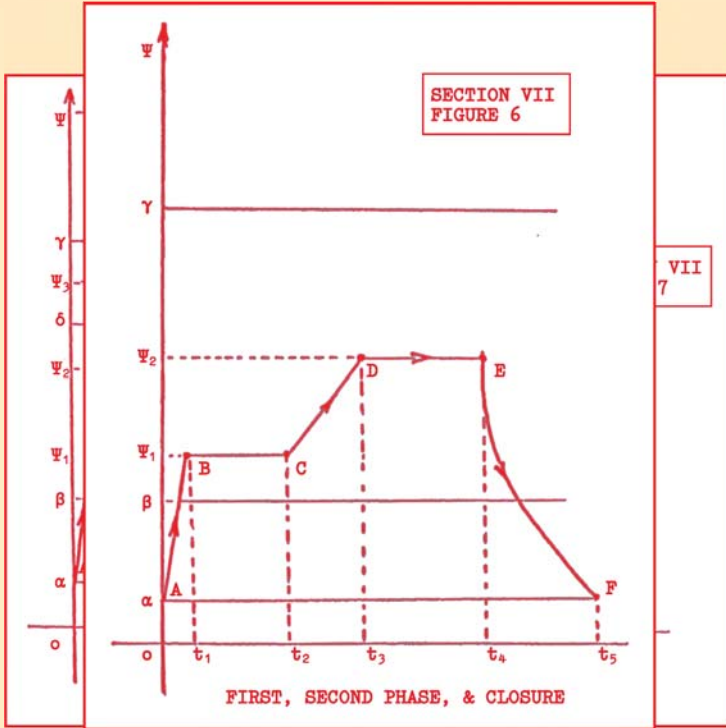

But if starting from the Ψ_2 level, the egregore assimilates energy in order to pass to the 3rd phase, the corresponding transformation can be seen in Figure 7.

The change of state occurs rapidly, transformation \overline{EF} , as can be seen from the short time (t_4-t_5) taken. The stable state is obtained upon reaching the Ψ_3 level at which the energy remains constant. It is useful to observe the \overline{EF} transformation in its environment in order to assess the influence of the threshold on the change of state. For this purpose we will have a graph that encompasses only zone III. See Figure 8.

In order to interpret this transformation it is useful to consider the \overline{EF} line as placed in two parts \overline{EZ} and \overline{ZF} . Thus we can say that the egregore, which was stabilized in the 2nd phase of the law, slowly increases its energy level without the possibility of reaching a stable level for the 3rd phase. But upon

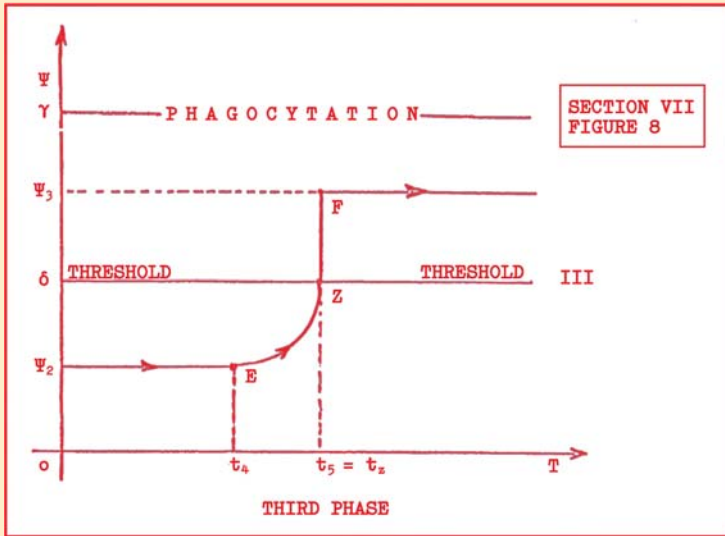

reaching a δ (delta) level, called the threshold level, there is an abrupt increase that places the egregore at the constant Ψ_3 level. The graph shows that the slope, i.e. the speed of the curve's increase, varies at the Z bend. From there on, segment \overline{ZF} presents an almost vertical line, which allows it to adopt a very high level of Ψ_3 psychophysical energy.

The threshold is a hurdle that must be cleared whenever the 3rd stage of the law is to be reached. But the *threshold level* is not always the same, it varies from one egregore to another and depends on multiple psychophysical factors such as: the number of members of the crowd, the Ψ_2 level, the dominant Archetype, telluric factors (which we will study later), etc.

The only “set points” in the psychosphere, if there is anything that can be considered as such, are the constant levels (α , β , γ) and these are “surrounded” by a dark fringe. The threshold, on the other hand, can be placed at any level *above* the constant \overline{DE} transformation, Figure 7.

We already know that the threshold level is variable, but we have not yet explained on what the existence of the threshold is based. We will do so now, bearing in mind that it is one of the most important concepts of the Psychosocial Strategy.

The threshold is generated by an *archetypal metamorphosis* that occurs when the egregore passes from the Shedim level, i.e., from the human level to the subhuman or animal level. This does not mean an Archetype *replacement* but an *archetypal metamorphosis* and, the ductility of the Archetype “ac-

tivated” by the egregore depends on the *nearness* or *remoteness* of the threshold. For example, in these reasons lies the convenience of using not only anthropomorphic images for the deities, but also zoomorphic ones and in the best of cases a mixture of both, since, in this way, the “evolutive distances” that separate the Paśu from the simple animal are bridged, facilitating the archetypal metamorphosis.

An archetype thus formed, a sphinx, a minotaur, is a powerful key for *approaching* the threshold and exercising great control over the crowd. This, and many others, have been secrets that have always remained zealously guarded by priests or initiates who were acting upon the psychology of the people. In this section we will return to the threshold and its determination.

Returning to Figure 7, we observe the constant Ψ_3 level, reached in this 3rd phase of the law, which we call *Shedim* (mixture of animal and man). The egregore here is inevitably “animal.” This means that the collective biorhythms “revert to animal rhythms” and that the collective conduct of the egregore is characteristic of the animal kingdom. Under these conditions it is feasible to provoke the avalanche of the 4th phase, i.e., the change of state that is characterized by an instantaneous discharge of energy. This effect, as we have said, is a reflection of the phenomenon of the “stampede” typical of animal populations. It is precisely necessary to reach the Ψ_3 level for the egregore to acquire the animal conduct that makes possible the avalanche of the 4th phase.

It can be seen in Figure 9 that it took a t_6 time, the sum of the previous times, for the egregore to accumulate the Ψ energy, the sum of the energy levels of the 1st, 2nd, and 3rd phases. But this energy accumulated in the long time (t_6) is discharged almost instantaneously in a very short time (t_1-t_6), which explains the name “avalanche effect” given to the 4th phase of the law.

It is not necessary to insist that such a “discharge” takes place on the crowd itself, the physical expression of the egregore, and that the 4th phase means “*crowd in a directed movement.*” Of course, “directed” insofar as the orders and aims of the mobilization have been *previously* implemented, since once the avalanche happens, just as in an animal stampede, the crowd remains uncontrolled, left to the “will” of the egregore.

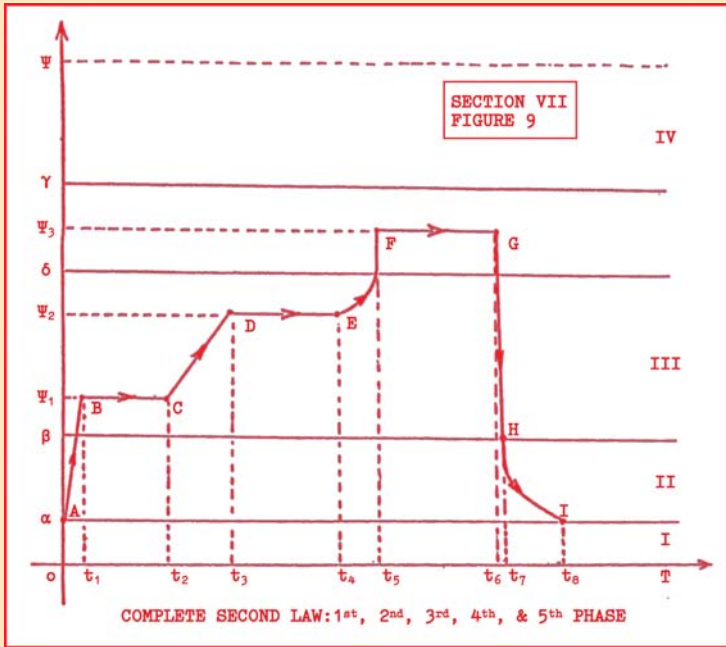

Let us thus verify, Figure 9, that the 4th phase is an almost vertical “transformation” that concludes at the β level, the borderline between the universal collective unconscious and the individual collective unconscious, *automatically* leading to the change of state that the Second Law considers, in its 5th phase, as the extension of the egregore and the closure of the phenomenon.

Likewise, in Figure 9, we can confirm that the 1st, 2nd, and 3rd phases each consist of two transformations, one of variable energy and the other of constant energy. In effect, the 1st phase is represented by \overline{AB} and \overline{BC} ; the 2nd phase by \overline{CD} and \overline{DE} ; and the 3rd phase by \overline{EF} and \overline{FG} .

In contrast, the 4th and 5th “discharge” phases each consist of a variable (decreasing) energy transformation. It can be seen that the 4th phase is represented by \overline{GH} and the 5th phase by \overline{HI} .

The Mystique of the Runes



he primitive Germanic or Teutonic language already inherits a much earlier word: “rún.” Although its immediate significance in print, for a person of the Germanic Iron Age, signifies much more, it is relatively recent that we understand a “letter” as a simple typographic character. Its meaning as a “message” still persists, and this, coincidentally, is more developed in the way of thinking than Germanic languages (English, German, etc.) imply. Etymologically, “letter” comes from the Latin “littera”; but let us not forget that, among the Latins, it also means “carta misiva”¹⁴² and that, with this meaning, “letra” appears for the first time written in Castilian in the year 1140 and this meaning is still preserved in the banking “letter of exchange.” Therefore, “rún” (from the plural “rúnar”) truly indicates: “Message, mystery of knowledge”... something that few initiates in the higher wisdom know well.

The straight line is the instinctive one in man for leaving a marked “message” with a hard material on something that is less hard (since the curvilinear line is more delicate and laborious to make). Messages must be left on durable materials and, instinctively, it is understood that scratching is more indelible than painting. Man knows that the sharp is able to defend him better than the blunt and he carries sharpened weapons, it being logical that he writes with these “tools” as well.

If there is an abundance of bone or wood, they are—for the certain durability of the message—easier to work with than the stone. In the original Danish environment of the rune, wood is an available material, but wood has grains that must be “differentiated” in order to avoid “confusion with the message” and for this reason, the straight lines are slanted or verticalized, avoiding horizontality. A coniferous tree is “useless” to mark, having birches; but these, in turn, have a shell that comes off in horizontal rings or rhytidomes, which “hinders” the horizontal line even more; in addition, the tree, when growing, generally better “conceals” the horizontal scars of its cork or bark due to its elementary plant physiology. The runes,

142. A delivered document.

therefore, “avoid the horizontal line,” as well as the curvilinear, since the curved surface of a trunk does not make the former “advisable.” A dexterous person writing in front of a tree, on its trunk, has an easier and safer work if he draws from right to left and, hence, this is how the primitive runic writing is made, which will last by custom and mystical ritual, later, even on other materials. The Phoenician alphabet, and those derived from it, including the Iberian alphabet, have strokes of apparently equal making, but these nuances of absent horizontality already persuade of a fundamental difference between the alphabets, the name of the first letters, and the Fupark, the same case, Proto-Germanic.

Archaeology has already come to demonstrate, indelibly, that primitive runes originate in Denmark. It is necessary to distinguish, very briefly, different periods of runic writing, the features of which vary in number and appearance, since they originate confusion about their “origin.” The Iberian-Etruscan alphabets (derived from/interrelated with Phoenician) confuse some authors who defend that, in the pristine contacts of Germanic tribes with Latin ones, the former “take the idea” from the latter and this origin would invalidate the subsequent one (equally inaccurate), which makes the runes originate in the translation that Bishop Ulfilas (fourth century AD) remade of the Bible in order to “Christianize” his Germanic people of the lower Danube (the Visigoths, i.e., “Goths of the West”); he translates the Bible, utilizing/inventing a Gothic alphabet, of 27 letters, of which 19 or 20 can be investigated as originating from uncial Greek, 5 or 6 from a modified Latin, and only 1 or 2 from authentic runes. But Gothic and other earlier Germanic languages are already different from primitive runics in their writing, however much they end up supplanting it and making it, each time, more and more reconditely sacred in the face of this true religious persecution. Even Gothic, as is well known, evolves repeatedly over the centuries (Anglo-Saxon, Anglian, Teutonic, etc.) but... not even in its origins was it runic!

The sacred and primitive runic language and its religious scripture persists increasingly located in the geographical area that gave it origin and to the north of it, taking refuge, until its last vestiges were utilized in Scandinavia at the beginning of the nineteenth century, in a modality of 16 letters originated in the eighth century.

Runic Alphabets

Elder Futhork

1	ᚠ	Fehu
2	ᚢ	Ūruz
3	ᚦ	Thurisaz
4	ᚨ	Ansuz
5	ᚱ	Raidō
6	ᚷ	Kauna
7	ᚷ	Gebō
8	ᚹ	Wunjō
9	ᚻ	Haglaz
10	ᚾ	Naudiz
11	ᚿ	Isaz
12	ᚰ	Jēran
13	ᚱ	Eiwaz
14	ᚳ	Perþō
15	ᚴ	Algiz
16	ᚵ	Sōwilō
17	ᚶ	Tiwaz
18	ᚷ	Berkana
19	ᚸ	Ehwaz
20	ᚹ	Mannaz
21	ᚺ	Laguz
22	ᚻ	Ingwaz
23	ᚼ	Othala
24	ᚾ	Dagaz

Anglo-Saxon

1	ᚠ	Feoh
2	ᚢ	Ūr
3	ᚦ	Thorn
4	ᚨ	Ōs
5	ᚱ	Rād
6	ᚷ	Cēn
7	ᚷ	Gyfu
8	ᚹ	Wynn
9	ᚻ	Hægl
10	ᚾ	Nȳd
11	ᚿ	Īs
12	ᚰ	Gēr
13	ᚱ	Ēoh
14	ᚳ	Peorð
15	ᚴ	Eolhx
16	ᚵ	Sigel
17	ᚶ	Tīr
18	ᚷ	Beorc
19	ᚸ	E(o)h
20	ᚹ	Mann
21	ᚺ	Lagu
22	ᚻ	Ing
23	ᚼ	Ēðel
24	ᚾ	Dæg
25	ᚿ	Āc
26	ᚰ	Æsc
27	ᚱ	ȳr
28	ᚳ	Ēar

Younger Futhork

1	ᚠ	Fé
2	ᚢ	Ūr
3	ᚦ	Thurs
4	ᚨ	Óss
5	ᚱ	Reið
6	ᚷ	Kaun
7	ᚷ	Hagall
8	ᚹ	Nauðr
9	ᚻ	Íss
10	ᚾ	Ár
11	ᚿ	Sól
12	ᚰ	Týr
13	ᚱ	Bjarkan
14	ᚳ	Maðr
15	ᚴ	Lögr
16	ᚵ	Yr

Runic is an “alphabet” (Fupark) totally different from other European ones. Its letters have a very different order; each letter has its own special numerical value; it bears a mythological name, either of a divine animal or plant species; of natural forces or phenomena; of sacred objects of everyday life in the Proto-Germanic cultural ambit. It is Fupark, in short!

The inventor—or inventors—of the pristine runic script not only knew the characteristics of the bark of a tree, as a foretaste of many other features of practical man, who rationally conceives the meaning and finality of his work, but, with his linguistic genius and artistic talent, was accompanied by a very strong religious sentiment, since the proper, significant names of each one of the runes are intimately related to very ancient features of the Germanic religion, as we have said... And this does not occur in any other alphabet, including the Semitic ones, known to date!

The patient work of philologists has not yet succeeded in elucidating the motives that led to order, as it appears, the Proto-Germanic Fupark. Even in letters that, by their shape, are reminiscent of letters of Mediterranean alphabets, it does not lead to the same order, sound, or symbolism. The study of so symbolic an “alphabet” requires sensitivity, erudition, and work; considering myself limited, I limit myself to “open a door” in the interest of others more gifted.

The 24 runes are grouped into three “ættir” of eight letters. Each and every one of them has a magical significance, which was undoubtedly giving, in its application, a transcendent meaning; if they were marked with great care, they were conferring special powers to the object that bore them. The magical intention “was recommending” to engrave them on a non-visible part (inside of the wedding ring worn by the woman, as needing protection in marriage; inside of the shield brace; the blade of the weapon, which from the sheath would have to go into the depths of the enemy’s body; the inner side of fibulas and brooches; etc.), since in the “visible” parts, the runes were “public,” indicating mere belonging, regardless of whether or not they had been bathed in sacrificial blood.

These runes are grouped into four related qualities of effects: Protective Runes that ward off danger, Medicinal Runes, Severe Runes that cause harm, and Victorious Runes.

According to their theme, they are classified into:

A. Runes of Higher Beings:

1. Rune of the Warrior and Sacrifice. Rune Tîwaz, Tîr, or Týr, which represents the god Týr. It symbolizes Honor. It will originate “t” and “d.”
2. Rune of the Æsir. Rune Ansuz, Ōs, or Óss. It will originate “a.”
3. Rune of the Superior Man. Rune Ingwaz or Ing, for the god Ing.
4. Rune of Giants. Rune Thurisaz, Thorn, or Thurs.
5. Rune of Mankind. Rune Mannaz, Mann, or Maðr. This rune can be classified in the following group. In some periods it was double according to the sex; it will originate “m.”

B. Runes of Divine animals:

1. Rune of Aurochs (Bison). Rune Ūruz, Úr, or Ūr. It will originate “u” and “y.”
2. Rune of the Elk. Rune Algiz, Eolhx, or Yr.
3. Rune of the Horse. It is the Rune Ehwaz or E(o)h, which represents the horses ridden by the Æsir.

Those of A and B are Severe Runes. These related to Water and Day Runes are a symbol of Creation, Genesis, etc., that is, protecting of the mother, etc.

C. Runes of Divine Plants:

1. Rune of the Yew. Rune Eiwaz or Ēoh. It symbolizes the honorable death in combat or sacrifice.
2. Rune of birch or poplar. It is the Rune Berkanan, Beorc, or Bjarkan. It will originate “b.”
3. Rune of the Fruit Tree. Rune Perþō or Peorð.
4. Rune of the Leek. Rune Laguz, Lagu, or Lögr. It also symbolizes Water, the Ocean. It will originate “l.”

D. Runes of Natural Phenomena:

1. Rune of the Good Year. Rune Jēra, Gēr, Ár.
2. Rune of the Storm. Rune Haglaz, Hægl, or Hagall. It has three meanings; the Rune of Hail, the symbol of natural Death; the Rune of Rain and Life. Both of these are united in the Rune of the snowflake, which is the Rune of Life and Death together or “Hagel” (The Hagel Rune of the fallen ones). It will originate “h.”

3. Rune of the Sun. Rune Sōwilō, Sigel, or Sól. It represents the Victorious Sun (Sieg in German is Victory). It will originate “s.” As the sun is “eaten” in Ragnarök or the Twilight of the Gods by the wolf Fenrir, the Rune of the Wolf or the Rune of Combat was derived from the Rune of Victory. The “reinforced” Solar Rune originates the well-known “Swastika” (by gathering four capital Gamma [Greek] letters), which represents the immortal racial life force. This rune also represents the god Thor, with his thunderbolts.
 4. Rune of Day. Rune Dagaz or Dæg.
 5. Rune of Ice. Rune Isaz, Īs, or Īss. It will originate “i.”
- E. Cultural Ambit Runes: (The first two may be included in the previous group).
1. Rune of Sickness (Ulcer). Rune Kauna, Cēn, or Kaun, which mean whip and torch, as instruments of injury and healing. It will originate “k.”
 2. Rune of Fatality (Necessity, Slavery, Harship). Rune Naudiz, Nȳd, or Nauðr. It will originate “n.”
 3. Rune of the Chariot. Rune Raidō, Rād, or Reið, which is related to travel, riding, movement, and the Germanic one who was transporting the eternal flame. It will originate “r.”
 4. Rune meaning Gift. Rune Gebō, Gyfu, or Gār.
 5. Rune of Well-being (Delight and Comfort). Rune Wunjō or Wynn.

The first and penultimate runes of the “Elder Futhork” are also considered to be of a cultural ambit, that is to say:

6. Rune of Livestock (movable goods that can be acquired, conquered, worked, etc.). It is the Rune Fehu, Feoh, or Fé, which will originate “f.”
7. Rune of Inheritance. Rune Othala, Odal, Ēðel, for Odin or Wotan. It will originate “o.” This rune represents inherited property; all that arises from the ancestors: education, ideas, etc. In German, *Ahn* is forefather and *Ahnung* is opinion, notion, reminder of, as a racial continuity, as a divine gift of blood.

To finish, I list the translated names of the “Elder Futhork.” Each group of eight runes is an “ætt” and I suggest that you meditate on them. The fact is, taken in order, 1st, 2nd, etc., within each group, there is a relationship not difficult to deduce:

1	ƿ f Livestock	u Bison	þ þ Giant	ƿ a Æsir	ƿ r Wheel	ƿ k Sickness	ƿ g Gift	ƿ w Well-being
2	h h Storms	n n Fatality	i i Ice	j j Good Year	p p Fruit Tree	i i Yew	z z Elk	s s Sun
3	t t Warrior	b b Birch	e e Horse	m m Mankind	l l Leek	h h Hero	d d Day	o o Inheritance