

The new racial classification (I)

All truth passes through three stages: first, it is ridiculed. Second, it is violently opposed. Third, it is accepted as self-evident.

(Arthur Schopenhauer).

NOTE: This article has been translated from the [original Spanish version](#), which was first published on July 28th, 2009. There is also a [Polish translation](#). We're interested in having it translated also to Russian, German, French and other languages. Contributions are welcomed in the inbox of [europa_soberana\(a\)hotmail.com](mailto:europa_soberana(a)hotmail.com) Some data of this article are outdated and are yet to be updated.

For decades, following the criteria of German, English and American physical anthropologists, the division of the European "sub-races" was as follows:

- **Nordic:** high stature, rosy skin, athletic build, straight nose, well-developed chin, dolicocephalic, fair hair and light eyes.
- **Dalic or Falic:** high stature, robust and heavily built, rosy skin, blond hair, light eyes (blue, grey or green), dolicocephalic or brachycephalic cranium, big mouth and thin lips.
- **Dinaric:** high-medium stature, brown skin, slim build, aquiline nose, brachycephalic, dark hair and eyes.
- **Alpine:** medium stature, fair skin, heavily built, brachycephalic, brown hair, brown or light eyes.
- **East Baltic:** medium to low stature, fair skin, strong build, brachycephalic, light hair and eyes.
- **Mediterranean:** low stature, brown skin, physical constitution varying from gracile to slender, straight nose, regular features, dolicocephalic, dark hair and eyes.

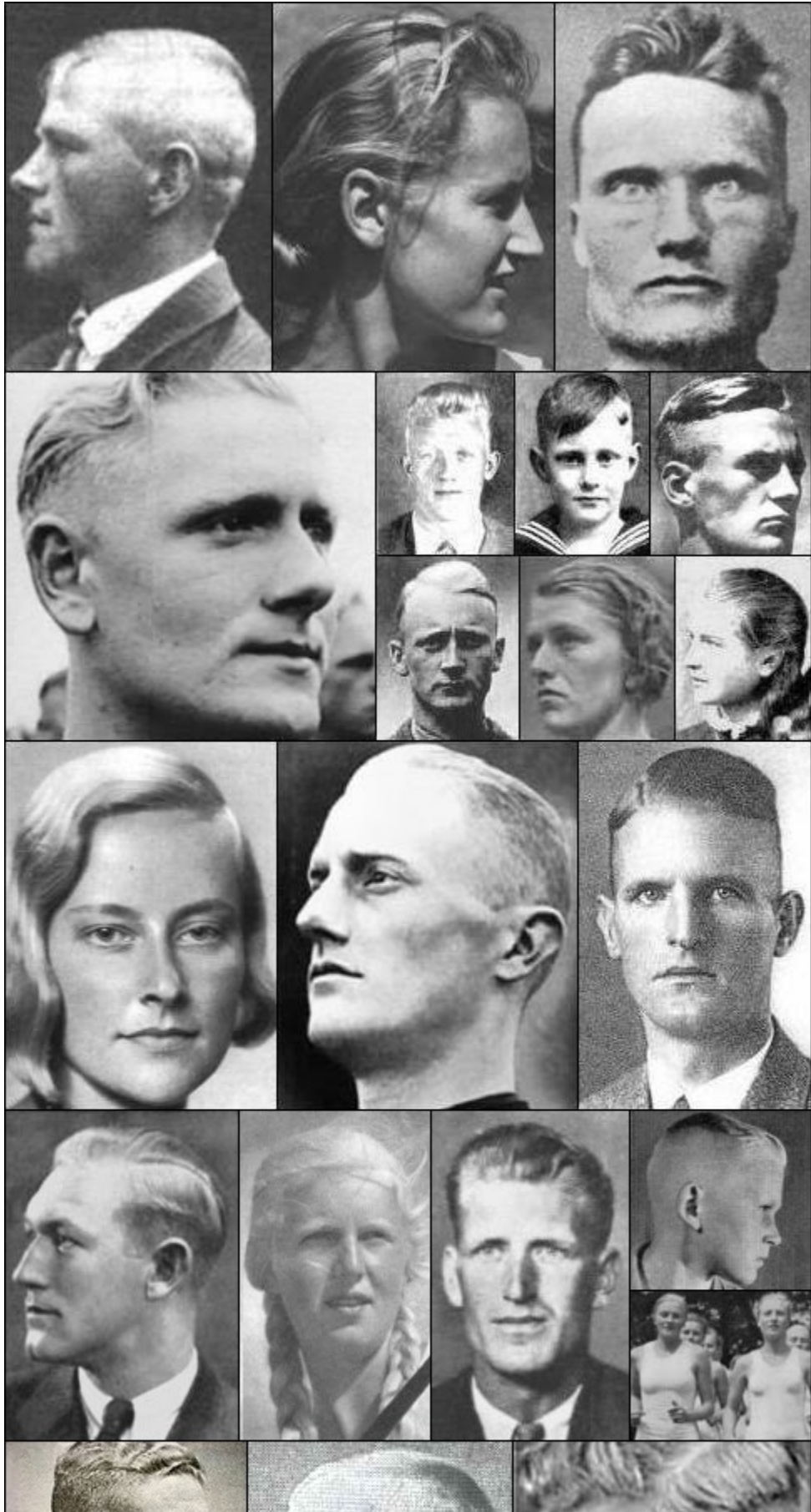

At the beginning of last century, these faces were designated plainly "Nordic", although it is clear that they do not constitute an anthropologically homogeneous group. Back then, they were grouped to put some order in the foundations of the young raciology. Today, we already are in a position so as to know what are the remarkable differences between these types.

This classification is obsolete. Although those who made it were on the right track, it has been fully improved, as could be expected after a century. The quantum leap has been made due to three factors:

- Thanks to globalisation and technical advances whereby we have easy access to high quality colour photographs of persons from different ethnic backgrounds worldwide. This is a luxury that physical anthropologists at the beginning of the past century (who had to content themselves with a very limited and black-and-white photographical supply) could hardly dream of. Due to this free access to physical-anthropological features, an update of the old racial classification was bound to occur sooner or later.

- The overwhelming advance in Genetics in the past years, specifically in human lineages (paternal and maternal) research from ethnic groups world wide, and their distribution in haplogroups. This research is still advancing steadily (e. g., X-chromosome haplogroups are in the process of being identified).

- The long, valuable and monumental investigation made by my contributor Valg in the field of Physical Anthropology **[1]**, and its meticulous verification with scientific data provided by Genetics (which has gone deeply into the origin of the different human ethnic communities, separating lineages), Paleoanthropology (which studies the physical-anthropological features of prehistoric men), Archaeology and History. Thanks to this ever-progressing work, Valg has been able to separate the current components in modern mixes, isolating the original features and finally going back to the lost primal races. Long before finding photographs of pure specimens, he already had in mind the features he was looking for. This search, which exceeds all previous ones and sets Physical Anthropology on a solid and totally new basis, has led him to discover that:

- What yesteryear was called "Nordic race" is actually a mix of White and Red Nordids, with an Armenid and, to a lesser extent, Mongolid influence.

- The "Mediterranean race" is a mix of Red Nordids, Armenids, White Nordids, Congids in small proportion and sometimes Mongolids in a minimal proportion.

- The "Dinaric race" is a mix of White Nordids and Armenids, usually with Red Nordid influence.

- The "Alpine race" is a mix of Red Nordids, Mongolids and generally, to a lesser extent, White Nordids and Armenids.

- The "East Baltic race" is a mix of White and Red Nordids, and Mongolids.

- The primal "European races" are three: the White Nordid, the Red Nordid and the Armenid.

The [most recent](#) studies on Population Genetics point out that modern Europeans are mostly descended from three distinct conglomerates of peoples, tending to confirm, rather than refute, the new racial classification:

- **WHG** (Western Hunter-Gatherers). The indigenous population of Europe. Mostly White Nordid race.

- **ANE** (Ancient North Eurasians). Mesolithic and Neolithic invaders. Mostly Red Nordid.

- **EEF** (Early European Farmers). Introduced agriculture in Europe. Mostly Armenid.

This article has not been written to promote divisions or discriminations, or to heartlessly catalog the human being like cattle or as a mechanical entity, but to understand better the biodiversity we are carriers of, the necessity of preserving it and its meaning, as well as to heighten people's racial instincts in order to achieve a selection of the best genomes. This is especially important when the vast majority of individuals are totally lacking an ethnical instinct, while the Western Civilisation is undergoing an aggressive invasion and colonisation process that threatens to drown forever its valuable autochthonous genetic diversity, and when the biological degradation brought about by civilisation (hazardous substances, pernicious habits, lack of natural selection and of a eugenic mentality) is making the West cry out for new identity feelings and associations based on Genetics. Therefore, I want to make it clear that if I touch these matters it's because I honestly think that they will contribute to strengthen our Western Civilisation, our "white race" —which lives within it and constitutes its base— and all mankind. This is about the history of our blood. Those who think

we are all equal or that all this is nonsense, are kindly invited not to read any further. We are not interested in convincing, but in providing the facts whereby clearly and free-thinking individuals can convince themselves if they deem it appropriate to do so.

To finalize this introduction, it is recommendable to deepen in morphopsychology, that is, analyzing the psychology of an individual using his physical features, especially of his face. It will be found that pure races, having particular features, have also a particular collective psychology, which is perfectly in accordance with brain configuration being inherited genetically.

FEATURES TO ANALYZE

In order to familiarize the reader with some terms, I would like to briefly explain the relevance of some features we will pay attention to later on.

- **Physical constitution:** We don't pay attention to whether an individual is thin, fat or muscular, but to his skeletal structure, his "framework" and his *natural tendency* to being thin, fat or muscular. With regard to the three races, the most corpulent is by far the Red Nordid. The Armenid has a gracile build, and the White Nordids an intermediate athletic type. During Paleolithic times, skeletal broadness was surely larger in all human races due to the strongly mineralizing diet.

- **Eyes:** The eyes' colour is determined by the melanin content, a pigment produced by melanocytes in the eye's iris. The "pure" eye colours are: dark brown (almost black), brown, light grey and dark blue. Green is actually a depigmented brown due to mixtures with lighter tonalities. Pale "bright" blue eyes are a mixture between light grey and dark blue (we do not take into account the pink and red colours of people with albinism, who are not a particular race).

Two (probably more, although they are not yet known) are the genes that influence the iris pigmentation: *HERC2* and *OCA2*. The *OCA2* gene encodes/synthesises a protein that transports tyrosine (precursor of melanin) and therefore determines eye pigmentation through the content of melanin in the iris (highly active *OCA2*= large amounts of melanin: dark eyes. Scarcely active *OCA2*= small amounts of melanin: green eyes). *HERC2* (a gene that regulates *OCA2* activity), in its mutated form, disconnects totally

the *OCA2* mechanism, hindering its expression, which in turn produces the light colour due to the lack of melanin.

How does the blue colour occur? In brown eyes, light is absorbed by the melanin contained in the external layers of the iris. However, in blue eyes, the outer layers have hardly any melanin, so that the light passes directly into the inner layers. There, light is scattered by proteins in such a way that, when reflected back out of the iris, it gives a blue tonality. This is the same optical phenomenon that makes the sky look blue. All colours between brown and blue (like hazel, amber or green) are determined by the amount of melanin involved in the process as well as the number and size of the proteins inside the eye.



A careful look at the iris can be almost as revealing as the facial features when it comes to appreciating racial contributions. None of these eyes has a "pure" colour, but mixtures between pure colours. The "pure" traits displayed in these eyes are brown eumelanin, dark blue and light grey, in varying proportions.

Obviously, we will also pay attention to the shape of the eye sockets, supraorbital arches, the size of the eyes and the distance between them.

• **Nose:** The nose says a lot about a race's environmental adaptation. E. g., in the case of White and Red Nordids (with slight differences between them), their nose—large when compared with negroid varieties and Mongolids, and small when compared with Armenids—is adapted to heating cold air in the nasal passages before introducing it into the lungs. In the case of the Armenids, their large noses were useful to increase oxygen intake in a rarefied air environment such as mountainous terrain, since Valg believes the Armenid race developed in mountainous regions (e. g., in chains like the Haraz mountains, Zagros, Taurus, Alborz or around the Caucasus). Another plausible theory is that it was

advantageous for dampening the dry desert air and filtering positive ions and dust particles before introducing it into the lungs. However, world climate was different when the Armenids appeared (during the Würm glaciation), and their regions (the Near East) were not deserts at that time. By contrast, the negroid races, which did not need to warm or dampen the air because rainforests are already warm and humid, have big nostrils and small nasal bridges.

- **Ears:** The "pure" types will be described, but we have to bear in mind that mixes produce a lot of "abominations", like protruding ears, very big ear lobes, etc.

- **Teeth:** Dental configuration is very related to craniomandibular configuration, that has a decisive influence on the brain and is the result of dietary adaptation. The origin of the human teeth lies in frugivorous apes, whose teeth had great differences between them (well developed canines and molars, under-developed incisors). During subsequent evolution, our ancestors began to use stone tools to butcher meat (and later on, by cooking it, they made it more bio-available and soft), and as a result, molars and canines lost prominence in favour of incisors. This resulted in more balanced and equated teeth, and in a more even distribution of the chewing force, which in turn freed the cranium from the "cage" of chewing muscles, allowing the brain to grow. Therefore, we must pay attention to the differences in shape and size between teeth, but also to the shape of the dental arch (e. g., a U, C or V-shaped "bite") and if the teeth grow angled outwards, vertically or tend to angle inwards.

- **Skin:** Everybody knows that melanin is the pigment responsible for darkening skin, eyes and hair, yet we are going to be more specific, and handle the little known concepts of *eumelanin* and *pheomelanin*.

- **Eumelanin** is the well-known dark pigment that people refer to when they speak of "melanin". It is to be found in skin and hair, it is the most abundant kind of melanin and there are two different varieties, black and brown. In hair, eumelanin produces colours like grey (small concentration of black or brown eumelanin, absence of other pigments), black (high concentration of black melanin), blond (small amount of brown eumelanin in the absence of other pigments) or mixes of these types (the different shades of brown, with or without grey hair, etc.).

- **Pheomelanin** is also found in skin and hair, and is especially abundant among thin-skinned people. This pigment imparts a pink to red hue and it becomes most apparent when little or no eumelanin is present. The highest concentrations of

pheomelanin occur in the lips, nipples, penis glans, foreskin and vagina of individuals of Red Nordid influence, so it is not necessary to describe the sensual connotations of tissues with this pigment. Pheomelanin reaches high levels in the hair of redheads and in rosy areas, or areas with a tendency to blush, of people with fair features —not only among eurodescendants, but also among individuals from Eastern Asia who carry some Red Nordid traits. As a matter of interest, there are distant Red Nordid traces in Africa (high levels of R1b can be found in Cameroon, split off the main R1b trunk 15,000 years ago and mixed in the maternal lines with the indigenous population) which show up in a slight tendency to maroon in the black skin of several ethnic groups, as well as in their facial traits. In the hair, high levels of pheomelanin produce an orange colour, which changes to a "fire" colour (when mixed with blond), to red (when mixed with black and brown) or to auburn (a bit of everything).

- **Another** gene that we will talk about here is the *MC1R*. This is a key gene in the regulation of hair and skin colour in mammals, particularly by controlling the eumelanin production. It is thought that mutations in the *MC1R* gene are responsible for fair hair. This is the first evolutionary step towards hair adaptation to an Arctic environment. The following step to this eumelanin depigmentation would be a higher pigmentation of pheomelanin.

How did fair skin develop, and why? White skin is the result of the adaptation to the lower intensity of sunlight in Arctic conditions, as well as to the reduction of skin surface exposed to the Sun, due to the necessity of using animal skins to keep warm. In a Nordic climate, the excess of melanin of dark skins does not allow enough sunlight to pass the skin and enter the body, which is essential to catalyze Vitamin D synthesis (skeleton robustness, immune system, mother's and foetus' bones). That is why, in Arctic climates, dark races (such as the Congid race) can only survive if they have a very plentiful and well-balanced diet, in addition to enough sunlight exposure. Otherwise, they may suffer from Vitamin D deficiency: weakness, decalcification and/or bone deformity, rickets, growth stunting in children, osteoporosis, bone fractures, predisposition to malnutrition, immune system collapse and other disorders. Dark races need high amounts of sunlight exposure (and/or a very complete diet) to produce enough Vitamin D, whereas fair races can get by with less light and food.

This is the reason why the Canadian and US health authorities [2] have advised dark-skinned people —mainly Afro-americans and Hispanics, but also dark individuals from Southern Europe— to consume between 1000 and 2000 IU (International Units) of Vitamin D from Autumn to Spring, when sunlight is

weaker. Perpetually dark skin is disadvantageous in any place that is not sunny and warm.

• **Skull:** Cranial morphology is important because it houses the brain and thus its shape has a direct influence in brain conformation and the development of certain areas and mental capabilities. We will talk about curvoccipital and planoccipital skulls (i. e., the shape of the rear part of the cranium) and about dolichocephaly, brachycephaly and mesocephaly (the ratio between cranial length and width).

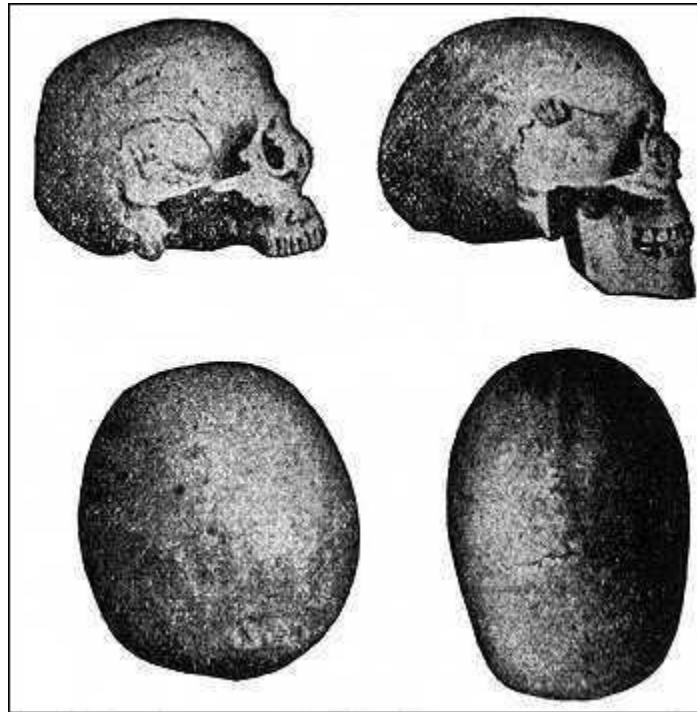

Difference between brachycephalic (left) and dolichocephalic (right) cranium, lateral and zenital (from above) view. A lateral view is not enough, as it only reveals if it is planoccipital (flattened occipital bone) or curvoccipital (prominent occiput). Only a zenital view can clearly reveal the cranial type. Notice that the dolichocephalic cranium is not only elongated but also the perception of its length is magnified by the narrowness at the temples (temporal bones) compared to the roundness of the brachycephalic, which is broader and has more prominent temples. An intermediate cranium is called mesocephalic.

• **Profile:** The evolution of the human profile is very interesting. It started from a primitive model with snout and no forehead. Thus, gracile mammals such as Plesiadapis, Smilodectes, or the more ape-like Aegyptopithecus, are thought to be ancestors of the hominids. As we moved into the hominid branch, that primitive "snout" (subnasal prognatism, or frontal projection of the lower facial parts) receded, the profile started to lift and straighten up and, gradually, a verticality of the profile was developed (orthognatism). The typical features of an evolved

profile, far from the apelike origin, are considered to be: a straight vertical forehead, a well developed nasal bridge and chin, and a lower jaw which is narrow when seen from the side, yet broad when seen from the front. In modern human races, the receding forehead is due to the Neandertal influence (as in the case of the Armenid race), as well as probably Erectus and others. The Red Nordids, Congids and Pygmids have perfectly straight and vertical foreheads, while the White Nordids have it faintly sloped. The most advanced chin morphologically is the Red Nordid, followed by the White Nordid, Mongolid, Khoisanid and Armenid. The most advanced nasal bridge is without question the Armenid (Neandertal in origin), followed by the White Nordid and the Red Nordid.

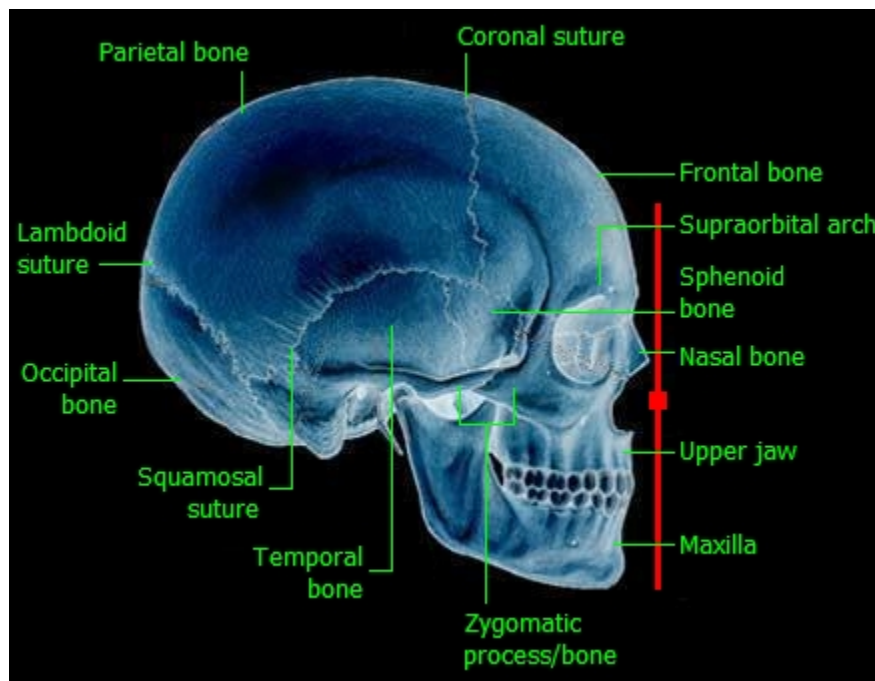

Curvoccipital cranium (we don't know if it's dolicocephalic because we can not see it from above or from front to know its width) and orthognathous profile (vertical red line).

• **Paternal lineage:** It is traced through the **Y-DNA** (DNA of the Y chromosome) analysis. As is well known, a woman has two sex-determining chromosomes XX, whereas a man has an XY pair. The Y chromosome is exclusive of males and is passed on from father to son, so that analyzing que Y-DNA provides useful information about our direct paternal line, i. e., "your father's father's father..." etc. Grouping diverse paternal lineages resulting from the genetic analysis of the Y-DNA of various populations, paternal haplogroups were formed. Women do not have a Y chromosome, so they can't know their paternal lineage unless they analyze the Y-DNA of a family male (father, paternal grandfather, brothers, paternal-side cousins or any other family member who shares direct paternal line —assuming that the family's women have been faithful).

• **Maternal lineage:** It is traced through **mtDNA** (mitochondrial DNA). mtDNA is located in the mitochondria, cellular organelles involved in metabolism and energy production, and is passed on exclusively through the female line, so that an analysis of the mtDNA reveals the maternal line. All of us have mitochondria in our cells, hence women, as well as men, can know their maternal lineage.

Y-DNA and mtDNA are non-recombinant, so they remain identical cross after cross, except when mutations take place. However, we *Homo sapiens* have, apart from the two sexual chromosomes, another 22 pairs of chromosomes (the autosomes). And besides, if we go back just 300 years, we have more than a thousand ancestors, so that knowing to of them is merely indicative, but nothing else.

How to know your own haplogroups? There are numerous companies which analyze genetic samples worldwide [3]. Some companies compare the results with databases, giving percentages of similitude with ethnicities and individuals from the whole world and providing the possibility of sharing genetic data to find family members. A basic analysis can reveal which is your paternal lineage (if you're a man, or a woman who has analyzed a man of her family) and which is your maternal lineage. For instance, the present writer has a R1b paternal haplogroup (a Red Nordid line) and maternal H (idem).

However, let's get one thing straight about haplogroups. As I already hinted, if we go back thousands of years, we have literally thousands of ancestors —although certainly many of them vanish from our genetic pool, as each parent only passes on a half of his genetic inheritance, while the other half is lost forever. To research the paternal lineage only speaks about one of them, and maternal lineage, about another. Therefore, it provides just knowledge of only two ancestors —two of thousands. Obviously, this helps to make ourselves an idea, yet it is not 100% reliable, because in order to appreciate all the genetic contributions, an analysis of the indirect lines, that is, of the **autosomes**, is required.

Just in case it is not clear, let me give a simple example to "demystify" the haplogroup issue a little: let's imagine a horde of vikings (I1 haplogroup) who disembark in Maghreb and sexually cohabit with some Moorish women, later leaving them behind and pursuing their expeditions. It is clear that the descendants will be of mixed race, and as they will breed on, their Viking contributions will be diluted more and more as time passes on. But they will still carry the paternal I1 haplogroup (as long as they have male descendants) as well

as certain genome regions originally associated with the I1 stock, which will manifest in extremely residual "Viking" features.

Something similar happened with the Indian and mixed populations of Latin America and the brave but senseless Spanish conquistadors: many South Americans that are clearly very dark and Indian-like, carry the R1b haplogroup, passed on by a Spaniard who did what he shouldn't with whom he shouldn't. This would explain the fact of clearly non-Red Nordid persons carrying the paternal R1b haplogroup like an inactive "souvenir" (though it's understandable that some vestiges of Red Nordid traits will be present, because 22 autosomes and a maternal lineage are also transmitted). The high frequencies of R1b found in certain ethnicities of northern Cameroon with clear residual Red Nordid traits, is another eloquent testimony of this same phenomenon. The opposite case is also possible: people that have a non-European direct lineage (like J2 or E1b1b) but are racially very European, because most of their "indirect" ancestors (neither paternal nor maternal direct lines) belonged to European lineages.

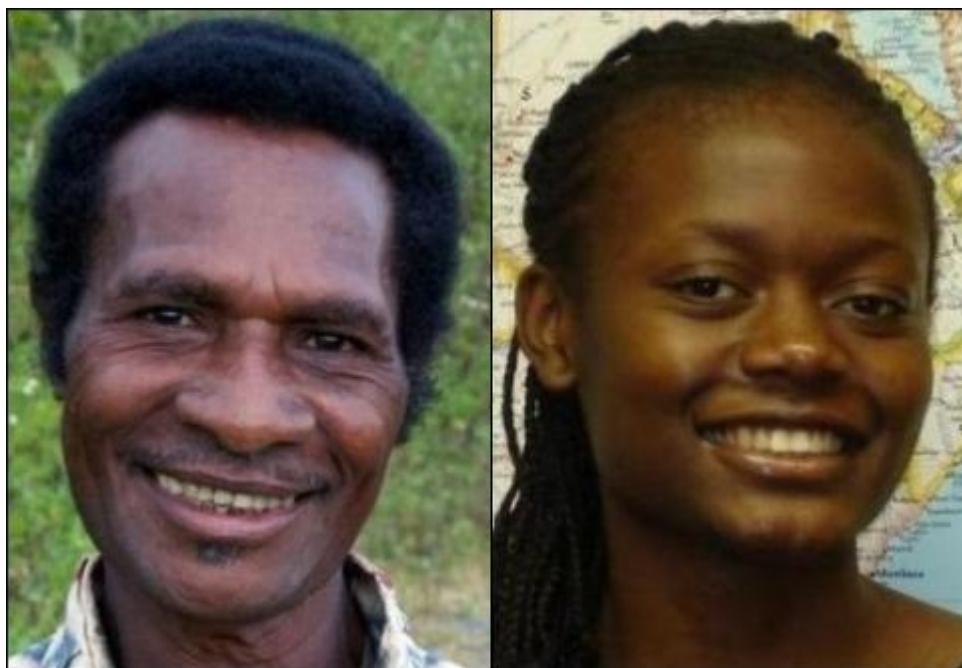

Many individuals with completely European features carry non-European haplogroups (e. g., the Italian painter Michelangelo Merisi da Caravaggio had the Congid E-V13 and Thomas Jefferson the Armenid T). To the contrary, these three examples—which come from zones of Sub-Saharan Africa with extremely high R1b frequencies, and display very apparent Red Nordid features— may well trace their paternal lineages to the R1b haplogroup, which in no way means they have "European genetics", but that, on their paternal side, they descend from Red Nordids (R1b1*) that reached that area 15,000 years ago, mixing subsequently with the native Congids and leaving scattered pieces of genetic information, like the shape of

the skull, lips, jawbones, etc. The same way, many South Americans with indigenous blood carry the haplogroup R1b, and nobody would think that it's an Amerind lineage, but that it was introduced by a remote Spaniard centuries ago. Let it be an example for those who insist on that "haplogroups have nothing to do with races or physical features" —of course they do, but only in origin.

Similarly, I know that my father's father... etc., was R1b, and that my mother's mother... etc., was H, but what happens with the other thousands of ancestors that I have? One should not get too "excited" about haplogroups, because things are not so easy and one must interpret them. Only a more deep genetic analysis, and/or an expert exam of the anthropological-physical features of a face, can determine reliably the racial contributions that run through somebody's veins.

Let's now see the racial types that have taken part in the sculpting of what we understand today as "white race".

EUROPEAN WHITE NORDID RACE (from now on, White Nordid race or WN). The most abundant racial contribution among the primitive "WHG" (Western Hunter-Gatherers) described by modern population genetics.



A pure White Nordid. Notice his skin is neither pale, nor milky-white, nor rosy or ruddy. It is rather "golden", in harmony with the hair, and seems suitable to get a moderate tan without getting burned when exposed to sunlight. Forehead is high but not completely vertical. Psychologically, this is a noble, harmonious, serene, serious, patient, well-balanced, martial, honourable, disciplined, honest, efficient and racist race, but also somewhat naïve, too angelic and not very cunning in many ways. Contrary to what his clothing might suggest, he is not Jewish, as there are various photographs of him wearing liturgical outfits from different religious confessions.



• **Stature:** Very high.

• **Physical constitution:** Slender, athletic. Well-shaped, broad and straight shoulders. Long neck. Although it is a "thin" physical type, tends to develop musculature under proper conditions of diet and exercise.

• **Eyes:** Ice-grey, very light, almost whitish. Sky-blue eyes are mixes between the light-grey shade of White Nordids and the dark blue of Red Nordids.

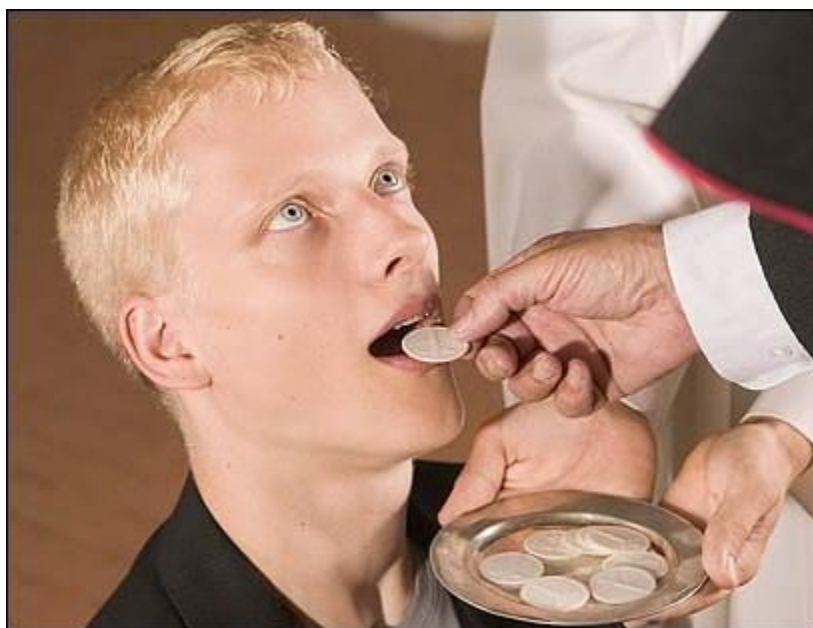

This tone, very light grey and near the colour of ice, is the eye colour *par excellence* of a pure White Nordid.

The grey eye colour is most common in Finland, the Baltic countries, Belarus and the European part of Russia. These eyes have even lower levels of melanin than "conventional" blue eyes, and the optical phenomenon that makes them look grey is the same that makes a cloudy sky look so. Elongated eye shape. Eyes deeply inserted in face under eyebrows that are low, narrow, moderately bushy and bring a thoughtful and audacious expression and a penetrating, aquiline and intense stare. Large pupils, short-medium distance between eyes. Small eye sockets. Moderately prominent supraorbital arches.

- **Nose:** Narrow, straight, not very fleshy, harmonious. The key of the White Nordid nose is that its "root" lies very high, almost in the forehead, so that the space between the eyes does not look deeply-set like that of Red Nordids. The White Nordid nose corresponds to the well-known "Greek profile" of classic statues, except that these present a slight armenisation, revealed by their forehead inclination and a slightly higher nasal bridge.

- **Ears:** Thin, elongated.

- **Mouth:** Thin and dark lips, with a clearly "sketched" outline. The philtrum (the medial cleft extending from the nose to the upper lip, dividing the moustache in two, also known as infranasal depression) is broad and clearly marked, in such a way that the central tips of the upper lip look separated and confer a slight "fed-up" expression, in the style of classic statues.



Here, the individual has his eyebrows slightly raised. When relaxed, the superciliary arches form a T with the nose. This imaginary T has its horizontal lines turned slightly downwards (something similar to the shape of an arrow pointing upwards).

- **Teeth:** Lined-up set of teeth, hardly much difference between the shapes and heights of each tooth.

- **Hair:** Platinum blonde, almost white, straight, thin and lank. When it grows, it tends to stick to the head.

- **Body hair:** Same colour as hair, very thin and sparse.

- **Skin:** Ivory-white, clean appearance. Pale when no suntan is involved. Low levels of eumelanin and pheomelanin, but the White Nordid race has the MC1R gene activated and the skin is thus able to synthesize melanin so, unlike the Red Nordids that we'll see later, this race can get a tan.

The White Nordid race is thus adapted to either letting the sunlight penetrate to the deeper layers of the skin (winter, pale skin) or to restrict its absorption (summer, suntanned). Unlike the Red Nordid race, which has undergone a more severe Arctic selection (they would be the real "ultra-Nordic" race) and has permanently lost the ability to produce melanin.

- **Skull:** Dolicocephalic (long seen from the side, little width, narrow temples). Curvoccipitaly (highly convex occipital and parietal bones). This race has developed cranial capacity backwards and forwards.

- **Face profile:** Not totally vertical but almost (forehead and chin scarcely receding). Straight and progressive (orthognathous, straight facial angle).



This is not a perfectly caught profile (the individual is somewhat turned backwards and his face is looking slightly upwards) but it is very indicative.

- **Forehead:** Straight, broad and almost vertical.

- **Jaw & chin:** Harmonious and well-developed jaw. The chin is between the prominent and massive type of the Red Nordids and the retracted one of the Armenids, but closer to the RN model.

- **Other features:** Facial features betokening kindness, benevolence and balance. Neoteny: a very youthful appearance, maintained until a very advanced age (although not as much as the Red Nordids). Pale and golden image. Abundance of athletic and active women, attractive and of great beauty, which have resulted in a very high reproductive success of White Nordid maternal lineages. Distribution of White Nordids could be vaguely connected to the A blood type.

- **Paternal lineages (Y-DNA):** I (I1, I1b, I2a, I2b, etc.). Valg believes that the I2 lineages could be Armenid and not White Nordid.

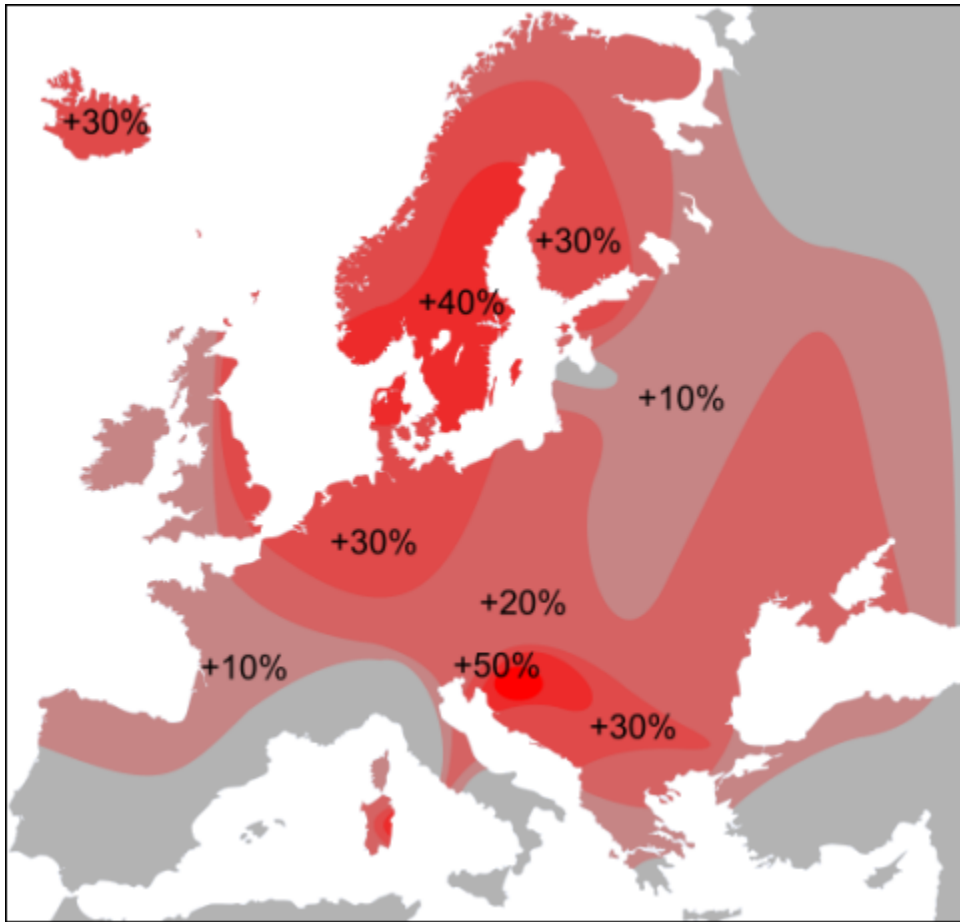

Approximate distribution of paternal I lineages in Europe. Source: Eupedia.com

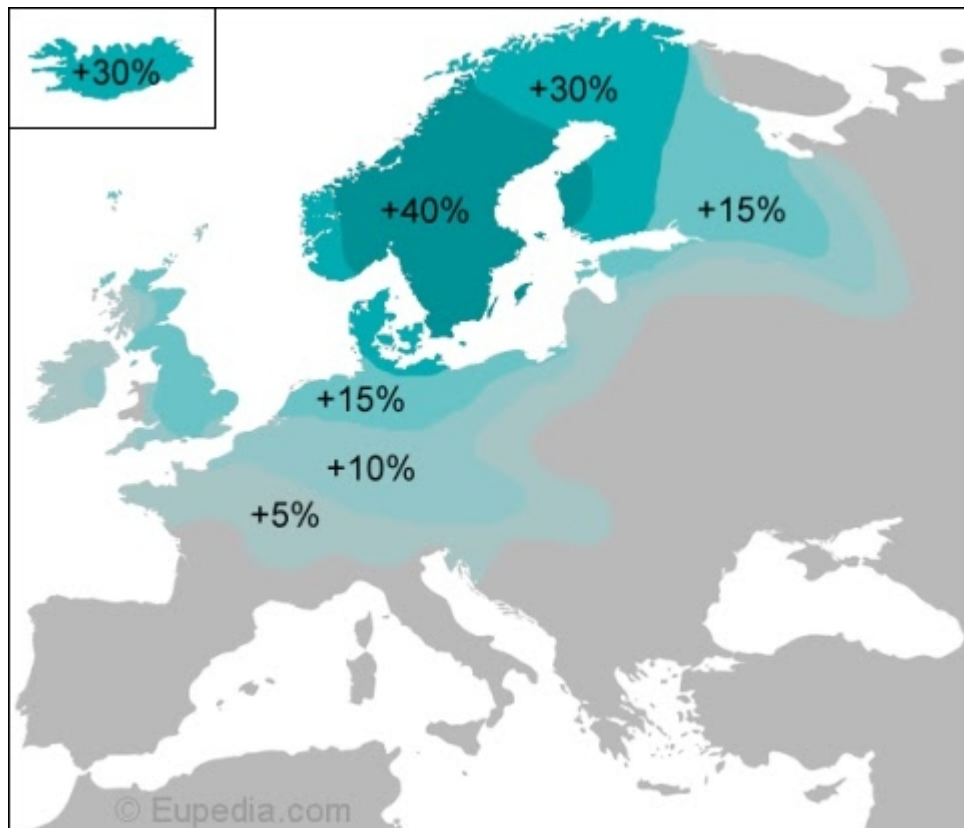

Haplogroup I1 distribution (previously called I1a, corresponding to Scandinavian types like the Vikings or the Normans). The ancient carriers of this haplogroup were Cro-Magnon clans coming from the Franco-Cantabrian region. Chasing animals that were migrating along with the thaw during the post-Magdalenian Mesolithic, they ended up occupying Scandinavia and Northern Germany, previously covered by ice. Map source: Eupedia.com

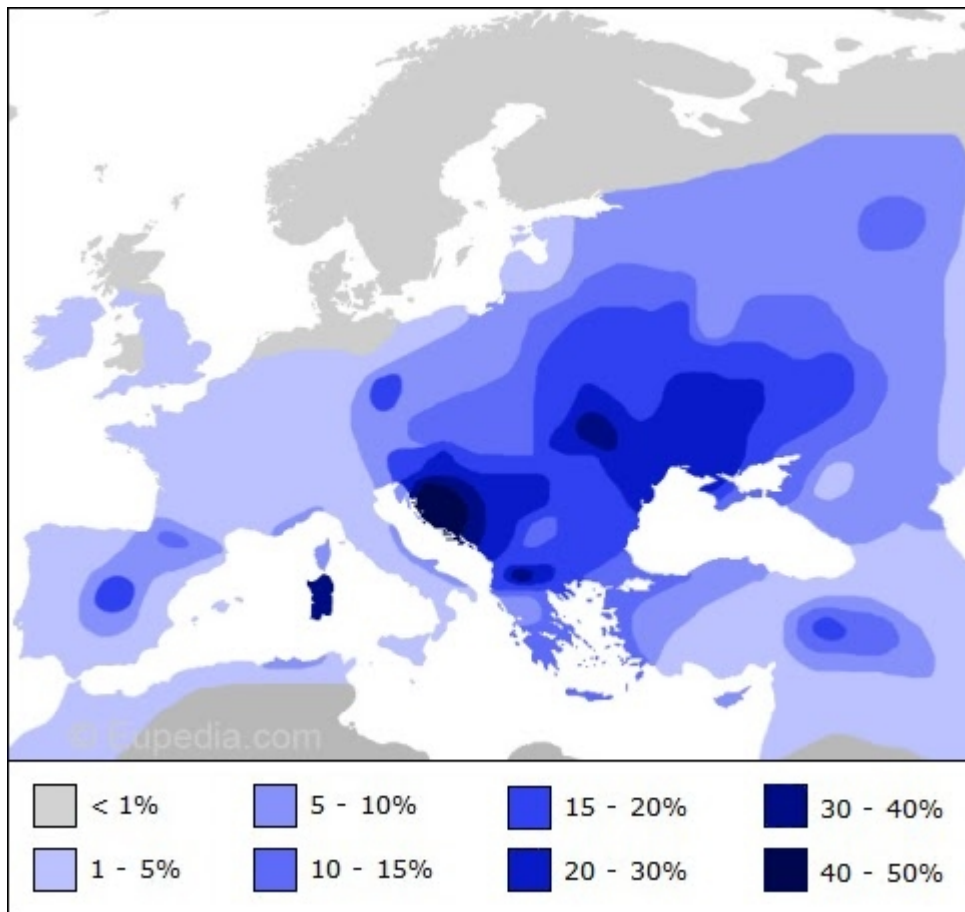

Haplogroup I2a distribution. Source: Eupedia.com

• **Maternal lineages (mtDNA):** U, K. Not all U sub-lineages are White Nordid in origin. We believe many of them (particularly the oldest ones) to be Armenid.

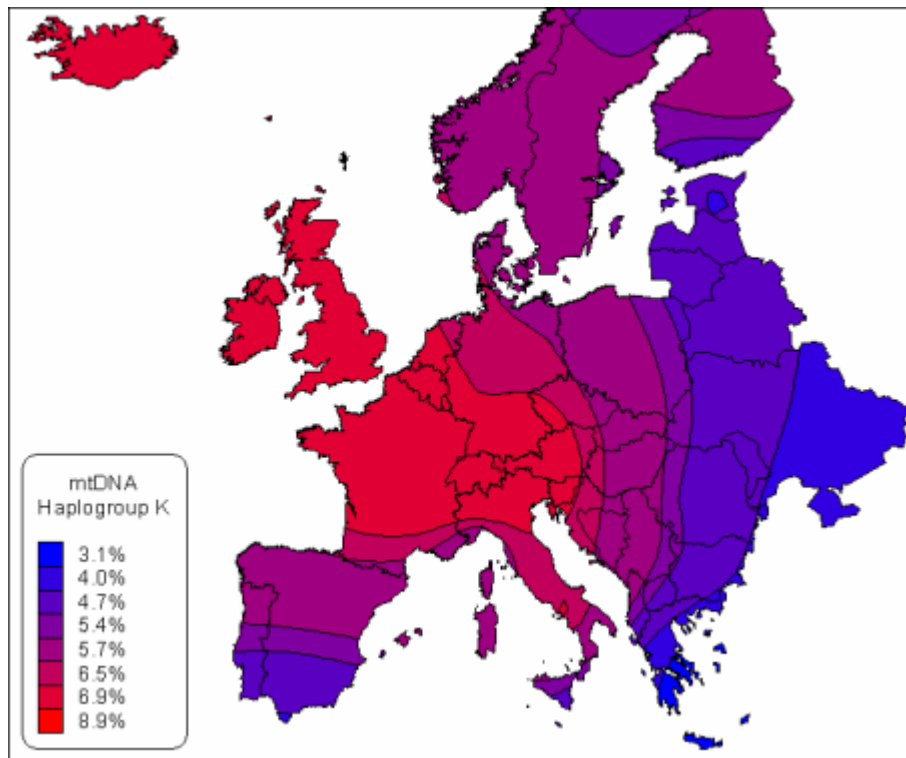

K maternal lineage distribution in Europe.

- **Spirituality:** Related to the sky. Worship of ancestors and fallen in combat. Cults of war and virility. Gods of justice, honour, war and order. Esteem for a short and glorious life, ended with a *mors triumphalis* or "triumphant death".

- **Psychology, idiosyncrasy and racial character:** Love for honour, attachment to order, respect for authority and seniority, warlike and military vocation, courage, altruism, loyalty, racism, heroism, self-control, discipline. Intelligence, thoughtfulness. Highly developed willpower, leaning to sports training. Eagerness to explore.

Also innocent, unable to cheat, and useless in diplomacy. This race is not shrewd, not because it lacks intelligence, but due to an "angelical" way of understanding the world. This makes them vulnerable in a degraded and debased modern society, so that darker and more primitive racial types tend to take advantage of them. It's the myth of the unworried and trusting Siegfried and the "stab in the back" archetype.

- **Distribution:** The White Nordid race has its heartland in the Scandinavian countries (being Southern Sweden the purest core), and also in North America, Oceania, Great Britain, Netherlands, Germany and Poland. However, its heritage

can be found in all Europe, both Americas, Middle East, Southern Asia, Siberia and North Africa.

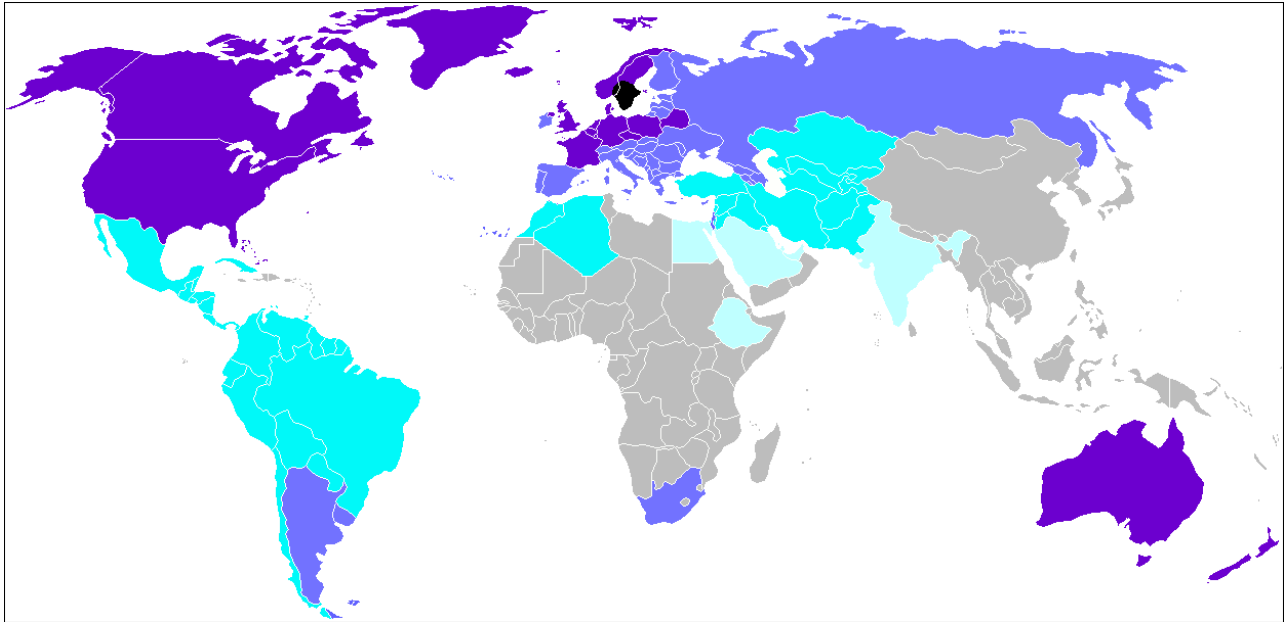

Distribution of White Nordid traits by country. Countries with larger quantity and/or purity of White Nordids are darker. Although this map is very general, it needs no further comments, everyone can recognize it in general terms. It would be interesting to make this kind of maps by regions, not by countries, but it poses too many complications.

• **Brief history:** We think this race arose approximately 40,000 years ago, when most of Northern Europe was covered by ice. In that period, human groups had gathered in geographical pockets of Southern Europe (especially in the Franco-Cantabrian region, the Balkans, and to a lesser extent, Italy and Eastern Europe), which were ice-free. We call this race "nordid" because during the glaciations, temperatures were much colder in the entire planet. The Sahara was a fertile region, whereas Southern Europe was under pure Arctic conditions, very similar to present-day Northern Finland.

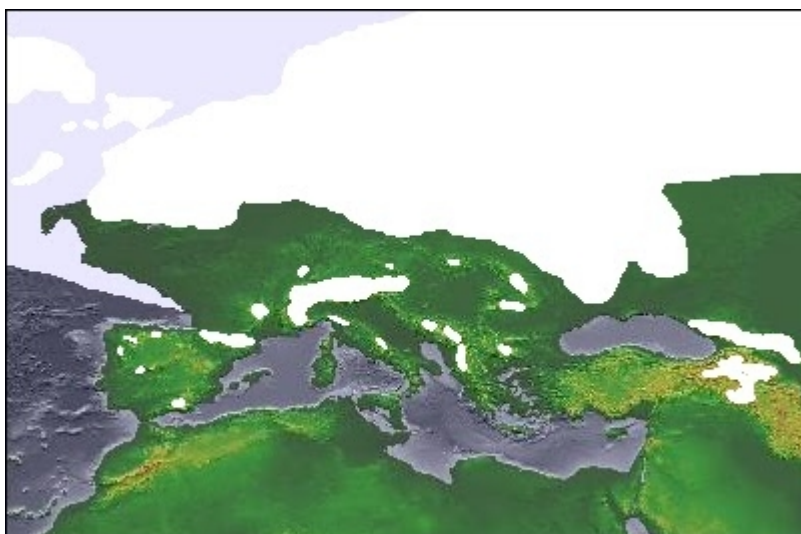

These maps are never 100% accurate, as the glaciers and sea levels fluctuated and waned with numerous ups and downs (the map wasn't the same during the last Glacial Maximum than during beginning of the glaciation), but even so, it helps to give an idea about what our continent looked like during the Würm Glaciation. Glaciers are shown in white, but we have to bear in mind that the snow-covered area must have been greater, especially throughout winters, during which there probably wasn't a single snow-free patch of land in Europe.

Haplogroups genetics indicates that White Nordids —associated with I haplogroups— mutated and therefore evolved from Armenid ancestors. The IJ lineage (that appeared 40,000 years ago), split in two parts, giving rise in the Near East to the J haplogroups ("Semitic"), and in Europe to I haplogroups, which resulted from Arctic natural selection and are dated in 25-30,000 years (see chart in the "evolution of lineages" section).

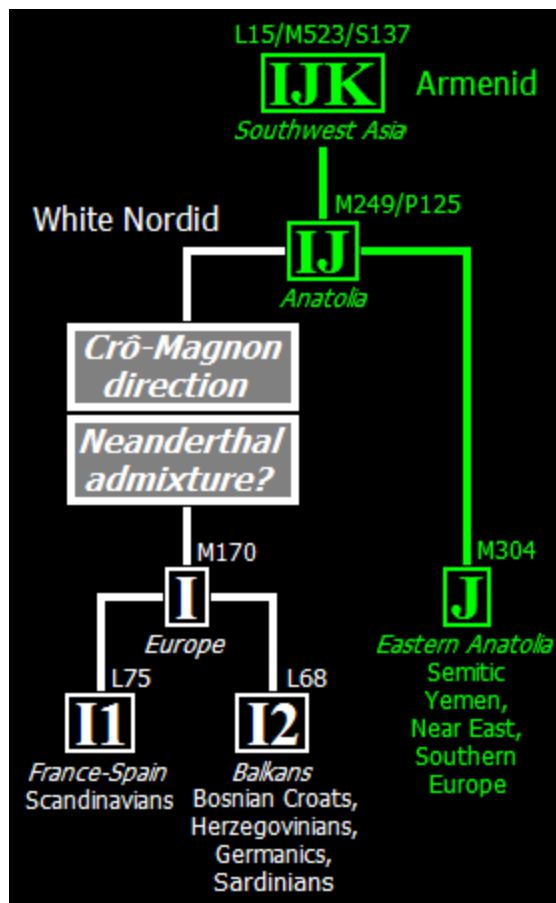

Suggested origin of WN (white) by paternal line. J poses some interrogators as to its adscription to the Armenid race (green); it's possible that it belongs to a pseudo-Nordic race. Valg considers I and I2 could be not WN, but Armenid. I believe that if Cro-Magnon had fundamentally WN physical traits and belonged to the IJ lineage (or at least to the European side of IJ), he couldn't have produced Armenid descendants. Valg also thinks it's possible that I2b1 could have been Red Nordid. In this idea, J could have belonged to a pseudo-red race, which would be a link between both Nordids.

It is not exactly known which was the first Cro-Magnon culture, as many doubts still linger as to whether the Gravettian culture belongs to Neanderthal man. The Aurignacian culture, to the contrary, does seem to be clearly Cro-magnon. Either way, we should not confer excessive importance to material cultures. The simple fact of using a same lithic technique to make spearheads (or later on, pottery decoration) doesn't make them all belong to the same people, but rather points to a spread of knowledge —cultural, not genetic, in nature. To consider all these people as part of the same population just on the basis of inanimate stones would be the same mistake as assuming that during the late 19th Century, the English and the Japanese belonged to the same people just because they had adopted the industrial-technological system.

During the Last Glacial Maximum (approximately 23-17,000 years ago) there must have been a high mortality rate, many communities probably became extinct, and no trace was left of the Gravettian and Aurignacian cultures. The Solutrean culture would flourish during these harsh millennia. As a proof of the devastating effect of cold, the Solutrean territory was more reduced and also more Southern than its predecessors. The Solutrean-Clovis theory suggests that, during the Solutrean, the North-Eastern American coast was colonized by European Cro-Magnons, who sailed along the border of marine ice that connected Europe with North America.

At the end of the Würm Glaciation (10,000 BC), the polar icecaps melted, retreating northwards and causing a sharp rise in sea level, which flooded some Cro-Magnon territories, especially in the French Cantabrian regions that are now part of the coastal bed-continental platform (some references to floods found in ancient myths could come from this event). During this period of climatic change which marked the end of the Pleistocene and the beginning of the Holocene, the White Nordids in Northern Spain, Southern France, Belgium and Southern Germany, synonymous with the Magdalenian lithic culture and with Cro-Magnon man, migrated to the North (as hunters, chasing animal packs adapted to cold, but perhaps also fleeing from the floods), crossing France and gathering mainly in Holland, Denmark and the Scandinavian peninsula (which was united with the rest of the continent until at least 8,000 BC), the German-Polish Plain and the Baltic basin, and gradually sweeping into modern Belarus, Ukraine and Russia. Another land to be populated must have been Great Britain, which, unlike Ireland, remained joined to the European continent until after the Neolithic migrations. In these geographical spaces, the Mesolithic Maglemosian culture thrived, and would be replaced over time by the Fosna-Hensbacka, Kongemose, Ertebøllian, Nøstvet-Lihult, Pitted Ware (still hunter-gatherers) and Funnelbeaker (Neolithic) cultures. These were societies with a clear seafaring vocation, dedicated mainly to navigation, fishing, hunting (especially marine mammals) and gathering. In many ways, they were precursors to the Viking societies that would flourish many millennia later. Some very convincing linguistic studies (such as "The IndoEuropeans" by Adriano Romualdi) prove that the mentioned territories should be regarded the homeland or *Urheimat* of the Indo-European languages.

Probably some communities remained in the ancestral Southern territories, being the main characters of Mesolithic (between Palaeolithic and Neolithic) horizons like the Azilian, Asturian, Geometrical Complex, Tardenoisian, Castelnovian or Sauveterian cultures. Something similar must have happened in the Balkans. It is not yet clear if the subsequent Megalithic culture is to be attributed to these

residual White Nordic tribes, or to the new Red Nordic invaders (who arrived around the Neolithic), or to both of them.

After some mix with Red Nordic and, to a lesser extent, Armenid elements during the Neolithic and the age of metals, the WN race will be present in the great Indo-European invasions and in the expansion of patriarchal, aggressive, warlike, solar and "Olympic" cultures. As a redoubt of the original European hunter-gatherer heritage, there remained a White Nordic pocket in Germania and Scandinavia (not counting communities in other regions as the Balkans or the Canary Islands) wherein the Cro-Magnon human type stayed essentially unaltered until relatively recent times. We accept that the Germans of the Roman period, as described by Tacitus in "Germania", were still pure or almost pure White Nordids, since according to the author:

For my own part, I agree with those who think that the tribes of Germany are free from all taint of intermarriages with foreign nations, and that they appear as a distinct, unmixed race, like none but themselves. Hence, too, the same physical peculiarities appear throughout so vast a population. All have fierce blue eyes, fair hair, and huge frames, fit only for a sudden exertion. ("Germania", IV).

These individuals' descendants, crossed with Red Nordids and Armenids (and to a minor extent also Mongolids and Congids), giving rise to the modern Germanic populations, mostly brown-haired. Nowadays there are no 100% pure White Nordic blood cores. The only option in this regard would be biopolitics, biosocial engineering, and a positive eugenics program to rescue the hereditary information that remains, hidden and badly combined, in the genetic pool of the modern "white race".

• **Present context:** Among all original human races, the WN is the one that has at present larger quantities of completely pure individuals, partly because it is probably the youngest race, and partly because historically it has displayed more racism than other races. Although it is extremely hard to find highly pure White Nordids (the photographs we use as examples are real jewels of Physical Anthropology) the most pure individuals and the largest proportion of them are to be found in Southern Sweden and south-Eastern areas of Norway, and matches roughly the distribution of the I1 haplogroup. However, numerically, we find more White Nordic blood in United States, Canada, Australia, New Zealand, Holland, Great Britain, Germany and some countries of Eastern Europe like Poland, Belarus, Russia, Lithuania, Ukraine and others. Such people come almost always

from relatively recent Germanic waves, as the Barbarians, Anglo-Saxons, Vikings and Normans.

ABOUT CRÔ-MAGNON MAN

Cromagnon is related to the White Nordid race and with ethnic groups like the blond Guanches of the Canary Islands (mtDNA U6b1), and is the oldest Homo sapiens of the European continent. Cro-Magnon appears in Europe about 40,000 years ago, during the period known by the Hindus as Krita Yuga or Satya Yuga, equivalent to the Greco-Roman "Golden Age" concept. Its origin is at present clearer: today, no serious palaeoanthropologist asserts that Cro-Magnon comes from Africa. The African hypothesis has not a solid foundation because, among other things, during a glaciation, it makes no sense to migrate northwards, where the environmental conditions become harsher, but southwards. Keeping this in mind, Jean-François de Quatrefages believes the Cro-Magnons to have come from Siberia in pursuit of big mammals, like bisons and mammoths, while others, as is represented in the Currat & Excoffier simulation ([here](#)), believe Cro-Magnon's ancestors to have come from the Near East, entering Europe through the Danube corridor. This last theory is consistent with Cro-Magnon's almost certain membership of the IJ lineage (which at that time was to be located in the Near East, i. e., a region whose nomadic tribes have always tended to penetrate Europe through the Balkans' "geopolitical magnet", just like the Red Nordids and Armenids would do later), and with the high levels of I paternal lineages found nowadays in the Balkans (with record frequencies amongst the Croatian population of Bosnia). It also coincides with the fact that the first most likely Homo sapiens archaeological sites within our continent are precisely located in South-Eastern Europe (like Peștera cu Oase in Romania, dated back to 41,000 years). The entrance in Europe may not have taken place through the Danube corridor. Maybe Cro-Magnon's ancestors crossed the Caucasus going along the Black Sea and sweeping over Ukraine before they arrived in Romania. This theory would be supported by the Gravettian sites found in Moldova, and by some indications suggesting some maternal U haplogroups could have crossed the Caucasus.

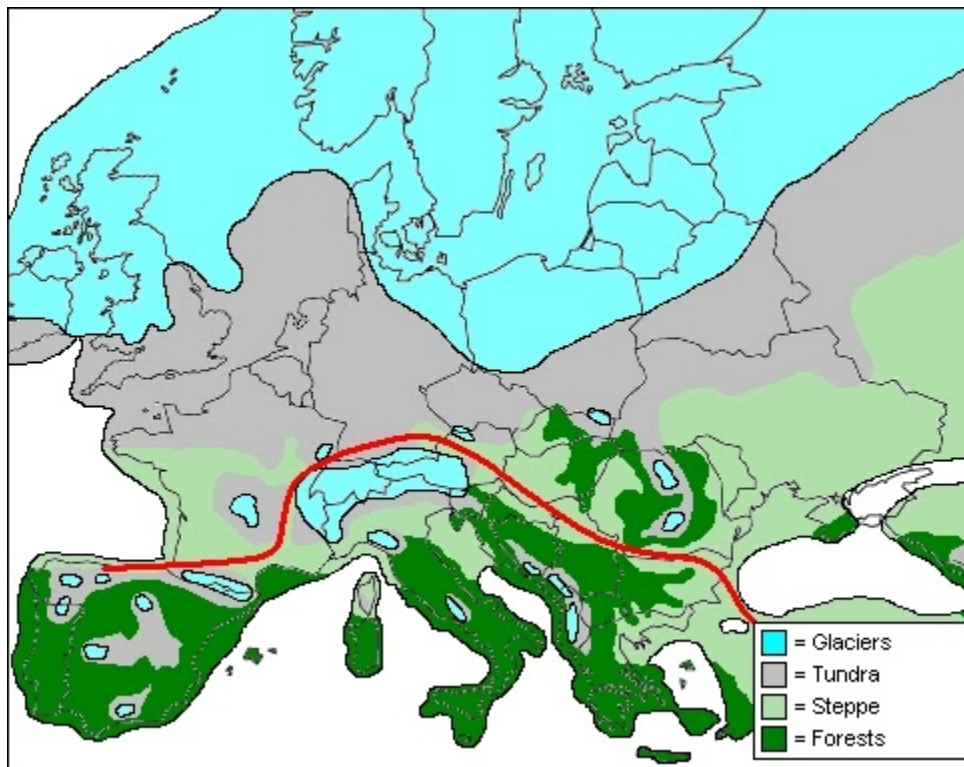

This map shows (red) the most probable route taken by Cro-Magnon and/or his ancestors to enter Europe. Another possibility includes a migration coming from the Caucasus, crossing Southern Ukraine and Moldova, bumping into the Carpathian Mountains and then heading towards the South, which would eventually lead them into the Danubian corridor. Most Cro-Magnon archaeological sites are located in territories classified here as steppes or tundra. Most likely, Cro-Magnons remained in these territories because the game (macrofauna such as mammoths, bisons, aurochs, etc.) was much better than in the Southern forests.



This map, being more schematic, might be more illustrative than the previous. We can see well the geopolitical particularities of our continent, full of natural barriers (mountain chains, but also the Mediterranean itself) that block any withdrawal towards the South, forcing reproductive communities to remain in Northern regions. As we can see, there aren't many options: the Cro-Magnon route was quite determined by geographical features (the Balkan mountain range, the Dinaric Alps, the Carpathians, the Alpine glacier, the Fino-Scandinavian ice cap, the Pyrenees and the Picos de Europa). At that time, mountain ranges must have been much more impassable than they are today, all the more for human groups loaded with women and children.

Besides, the distribution of the hunter-gatherer sites of the European Palaeolithic does not lead to a Southern origin at all.

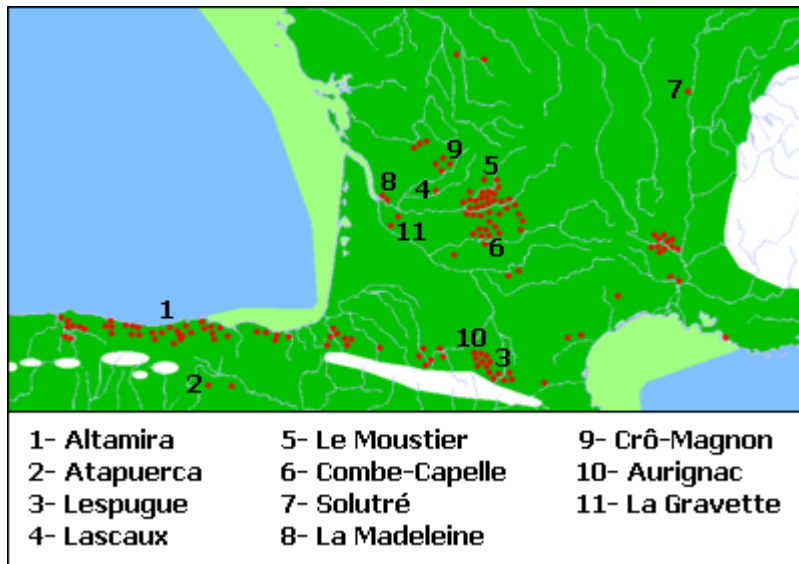

The French-Cantabrian refuge during the Würm Glaciation (until 12,000 years ago). During this period, environmental conditions were similar to those found at present in Northern Siberia. The light green areas represent emerged lands at that time (the marked coastal bed should actually house important archaeological sites under water). The red spots are human sites and the white areas represent glaciers. Although there are other sites in Southern and Eastern Europe, the portion represented in this map corresponds to the "classical" core with the highest density of Cro-Magnon sites: Green Spain and Southern France. The sites' distribution indicates that the settlers came from the East or perhaps the North, but in no case from the South, for these communities were obviously forced southwards by the glaciation, remaining gathered above the Pyrenees and Picos de Europa —which at that time must have been insurmountable ice walls. If they actually came *from* Africa (an absurd option in the middle of a glacial period, when migrating *towards* the South is a must) we would find them gathered *below* the mountain chains rather than above. Keeping into account the origin of the IJ lineage and the age of some human archaeological sites found in South-Eastern Europe, most likely, the ancestors of these Cro-Magnon communities entered Europe through

the same region as invaders from the Near East have always done: the Danube corridor. The Danube funnelled the invaders into Southern Germany (the Balkan mountain range was a glacier and probably could not be crossed) from where they had to head westwards (they could go neither southwards due to the Alpine glacier, nor northwards due to the polar ice cap). After coming across the glaciers in the Pyrenees, the next logical step would have been to round on the way to the West to finally spread along the Cantabrian region —exactly the same route the Red Nordids would take later.

The reason why Cro-Magnon can be related neither to the Red Nordid race nor to the R1b lineage is that during the period that Cro-Magnon appears in Europe, the K haplogroup (early precursor of R), was to be found nothing less than in Central Asia. Although a genetic analysis of the Cro-Magnon's Y-DNA hasn't been performed so far (Y-DNA decays faster over time than mtDNA), the scientific community accepts today that the only reasonable candidate for the Cro-Magnon paternal lineage and most of the hunter-gatherers of the European Upper Palaeolithic, is the IJ haplogroup, wherefrom the I haplogroup split off. It is then clear that the Cro-Magnons were an ethnic group of the White Nordid race, which evolved from Armenid ancestors (as a remote possibility, from Khoisanid ancestors, as we are not totally sure whether the IJ was already Armenid or if the armenisation of the lineage took place later and only in the K haplogroup branch). It is possible that some genetic contributions of the European Neandertal race passed on to the White Nordid genetic pool, just like the Eastern Neandertal race was present in the origins of the Armenid race.

If we look at the skull presented below, we will see essentially White Nordid features: dolichocephalism, a not totally vertical forehead, squared jaw, sharp chin (a well-developed chin is a relatively recent evolutionary feature) and a tall stature. With regards to Cro-Magnon's broad face and the heftiness of this type when compared to modern White Nordids, there is a simple explanation: Cro-Magnon's nutrition consisted of fresh products obtained from hunting, fishing and gathering —in other words, he had a hunter-gatherer diet, or paleodiet, which is by far the most complete form of nutrition. This diet, along with a more natural and healthy lifestyle, builds a stronger skeletal consistency, a higher muscular development and a wider face than the later cereal-based diet imported from the Near East during the Neolithic, which tends to blur sexual dimorphism (morphological difference between male and female). In his interesting study [Nutrition and Physical Degeneration](#), Weston A. Price shows that people with "primitive" diets develop perfect dental arches and above all, have wide faces and a healthy appearance, whereas people feeding on "modern" processed food

develop uneven teeth and narrow faces, not to talk about a general health deterioration.



This treasure of Paleanthropology is the skull of Cro-Magnon 1. It dates back to 30,000 years, yet his features and cranial capacity place him way ahead of most modern Homo sapiens from an evolutionary viewpoint. The more robust constitution and the square jaw of Cro-Magnon is due to a nutrient-dense palaeolithic diet which promotes optimal skeletal mineralisation and bone density. Other morphological differences with the modern White Nordic race (large nose with a low nasal bridge) could hint towards the existence of various Cro-Magnon varieties, of which only the correspondent to the White Nordic race has survived until our days.

Aurignacian culture was pretty much like an empire. The lithic industry was identical from Eastern Europe to the Iberian Peninsula. The Solutrean was a more reduced culture, for it took place during the Glacial Maximum, which must have dramatically reduced the population, driving it more to the South. The

Magdalenian was the last great hunter-gatherer culture of the European Palaeolithic, and the tendency its communities would follow during the end of the ice age, could already be foreseen: heading towards the Northeast, crossing France in direction to Friesland, the German-Polish plain and Scandinavia.

REFLECTIONS ON THE WHITE NORDID RACE

The White Nordid race, even before being identified as such, has been taken in many cases (the classical era, the Renaissance, neoclassicism, German nazism) as a prototype and an ideal-goal to achieve. Hence, it is not out of place to provide various reflections, some of which may also apply to the Red Nordid race.

1. The culture of predation and meat

Thriving in an environment similar to modern Finland, Cro-Magnon culture was, out of pure necessity, "the" hunter culture par excellence (spearheads, arrowheads, richly decorated spear throwers, harpoons, assegais, cave paintings filled with hunting scenes, whistles, horse's heads figures). For this reason, we should imagine them living a life of violent and constant physical activity outdoors. This developed them as an athletic, graceful, gymnastic human type, and when the climatic conditions got milder, this probably became more apparent. It is in the Cro-Magnon communities of Spain, France and the Balkans, where we have to look for the origin of Greek athletic traditions like races, javelin throwing, hunting, fighting and archery.

Because of the environment they inhabited, gathering was reduced to its minimum, whereas hunting and fishing were preponderant, together with the massive intake of animal fats and proteins. In turn, hunting pre-eminence is closely connected to predatory and masculine behaviour and psychology. For more information on the evolutionary effects of this diet, see the article on the [carnivorous revolution](#).



Cro-Magnon reconstruction, American Museum of Natural History.

2. Ethnic conflicts

Undoubtedly, the White Nordid Cro-Magnon had territorial conflicts with reproductive communities of other races. The first race they came into conflict with was the Neandertal, which had been around in the European continent for 200,000 years and had evolved from earlier populations, such as Homo heidelbergensis. The sudden disappearance of the Neandertal (the theory of "extinction by climate change" is very feeble because of the fact that Neandertals had already survived climate change —the Riss-Würm interglacial period— and that they became "extinct" in the middle of the ice age, 16 millennia before the deglaciation) suggests that both races waged an arm-wrestle (something completely normal in Nature when two different groups compete for the same territory) in which finally the Cro-Magnon triumphed. Without doubt, some interbreeding must have taken place between both races in Europe (apart from the mixes in the Near East, which are already proven genetically), as hybrid craniums have been identified. In any case, it is possible that there was a minor European Neandertal contribution to the development of the White Nordid race.



Two great human races that undertook a real titans' duel on European soil. The Neandertal (left) had been in Europe for 200,000 years. He had overcome both glacial and interglacial periods successfully and he occupied a territory spanning from Portugal to Central Asia. Despite his fabulous environmental adaptation, when Cro-Magnon (right) showed up, it took Neandertal only a few millennia to become extinct —suggesting that Cro-Magnon set very high standards in the territorial struggle. Maybe Cro-Magnon carried minor Neandertal traits that have become part of the White Nordid gene pool.

Nevertheless, Cro-Magnon's struggles did not end with Neandertal's "disappearance", as it has been proven by mtDNA traces that afterwards, other races entered Europe, specifically the Khoisanid and the Congid. The statuettes of [steatopygic Venuses](#) ([steatopygia](#) is a very common deformation in certain African khoisanized ethnicities) bear witness of such a presence, as well as some cave paintings similar to those found in Khoisanid Africa. The Congid contribution in Europe is visible in some undoubtedly "negroid" skulls found in Italy and Southern France —like [Grimaldi man](#).

Despite there being cases of race-mixing during the European Palaeolithic, the fact that nowadays there are still some pure White Nordids means that there were entire clans free from foreign genetic influences —we have to keep in mind that the Palaeolithic must have been the most racist and ethnocentric era in human history.

3. Acquisition of Nordid traits was very fast —possible causes of this accelerated evolution

Geneticists believe 850,000 years (!) of isolation and segregated selection to be necessary for the development of the extraordinary White Nordid phenotypic traits (and this also applies to the Red Nordids). There are several plausible explanations to this unprecedented case of "accelerated evolution":

a) This 800,000-year distance was cut down and sped up in time due to the fact that a strict conscious self-selection reigned among the White Nordid ancestors. This kind of selection intentionally tended to promote and increase only the genetic traits they wanted the future generations to carry. This race (as well as probably the Red Nordid) could have had leaders who watched over the quality of the stock and who submitted their people to a strict upwards evolutionary regime, similar to what a stockbreeder does with his flock. Also, the community itself would have been strongly aware of their evolutionary role.

b) A great relevance of sexual selection [4], besides the natural selection working under the rigours of an Arctic climate, which does not suffice to explain by itself the fast evolution of the Nordic races. Even so, it seems difficult that a race like the WN has arisen randomly and by chance: it seems to be the result of a "directed evolution".

c) The White Nordid ancestors acquired their traits due to a mix with an unknown race. It is possible that the modern, pure WN has part of genetic contribution from a European Neandertal race.

d) The existence of "benign viruses" within the reproductive community. A virus is simply an infectious agent (it is hesitated on whether they should be regarded as living beings) with an interesting geometrical morphology and that, despite having its own DNA, lacks the autonomy and the "machinery" to replicate it, and thus is unable to reproduce alone. Due to this, a virus needs to enter other organisms to use their cellular replication "machinery". Afterwards, it can inject its DNA in portions of the host's genome and infect another individual, repeating the same process. The virus itself can mutate and evolve through these processes, as it takes different portions of the genome of different hosts. Here, it is necessary to remember that there are millions of viruses in Nature and that most living beings are carriers of diverse viruses which are totally harmless for them, and whose role is unknown to a large extent because Science hasn't yet paid them much attention. That a virus ends up killing its host is an anomaly, since the most affected is the virus himself, which loses the genetic means to reproduce and survive. Most viruses are, if not beneficial, totally neutral; they just transport and transform DNA from one place to another. Today it is clear that

viruses are an important natural means of horizontal genetic transference, and that they greatly increase genetic diversity [5] —producing an ample amount of traits over which natural selection then acts to multiply only the advantageous ones. However, the most important role of viruses is to force their carriers to develop genetic adaptations to them. In a reproductive community subjected to natural selection and carrier of a certain pathogenic virus, every genome unable to develop congenital resistance against it would die out —in one phrase, the alleles (variants of a same gene) which are advantageous to fight a certain infection, get promoted thanks to natural selection. From then on, the survivors will all be carriers of the virus they have adapted to, so that, in practice, the virus has improved the reproductive community's environmental adaptation, killing off those who were not up to the circumstances and turning into another of those "harmless" viruses (only for the community) but with an important evolutionary role in the past. "Instinctive racism", or phobia to physical contact with other reproductive communities, might be motivated by the intuitive fear of being infected with other viruses one is not adapted to. It must not be forgotten that all the gestures of sharing skin and breath, from a pat in the back to a sexual relation (and shaking hands, hugging, kissing, caressing, etc.) are potential methods for interchanging viruses and therefore genetic material to a certain extent. In fact, if viruses had an important role in human evolution, we can imagine the catastrophe of mixing, through usual physical contact with other reproductive communities, "tribal viruses" that encouraged opposed adaptations (e. g. glacial vs. tropical or deserty).

e) Another thing that, in my opinion, is underestimated in human evolution is the common spirit and will at a community level, generation after generation, but obviously there is no scientific evidence to prove it or even hint it.

f) A combination of all or some of the previous points.

4. Consequences of the deglaciation.

The evolutionary effects of cold are treated in the article [Mysteries of ice](#). We know that 12,000 years ago, the ice age ended, the Pleistocene gave way to the Holocene and the Palaeolithic to the Mesolithic. Nevertheless, the thaw did not have the only consequence of the migration of the WN northwards —it also bought about a series of changes that somehow heralded the advent of civilisation.

To begin with, the climate change took the White Nordids out of the environment they were adapted to. Although they travelled towards Northern Europe, this would no longer be the land of steppes, tundra and frosty plains they had known before, but of densely wooded areas with milder temperatures. The fauna likewise changed: mammoths died out and megafauna was replaced by a more modest one, with a thinner layer of body fat. Furthermore, with the replacement of ice by boreal forests, the supply of vegetable products increased enormously. This entails that the gatherer role (associated with women) rose, while the prestige and dependence on the hunting role (associated with men) fell. The combination of climatic, nutritional and lifestyle variations must have had a pronounced metabolic and psychological change, that brought the harsh Palaeolithic world to an end, enhanced social feminisation and predisposed whole communities to the advent of civilisation and more crowded, herbivorous and populous ways of social life.

Despite this process, hunting was kept until very recently as a tradition within the social elites. The subsequent historical record of Indo-European tribes (being the vikings a very notable and recent case), as well as the presence of hunting deities, proves that predation was still deeply embedded in the psyche of these ethnic groups.

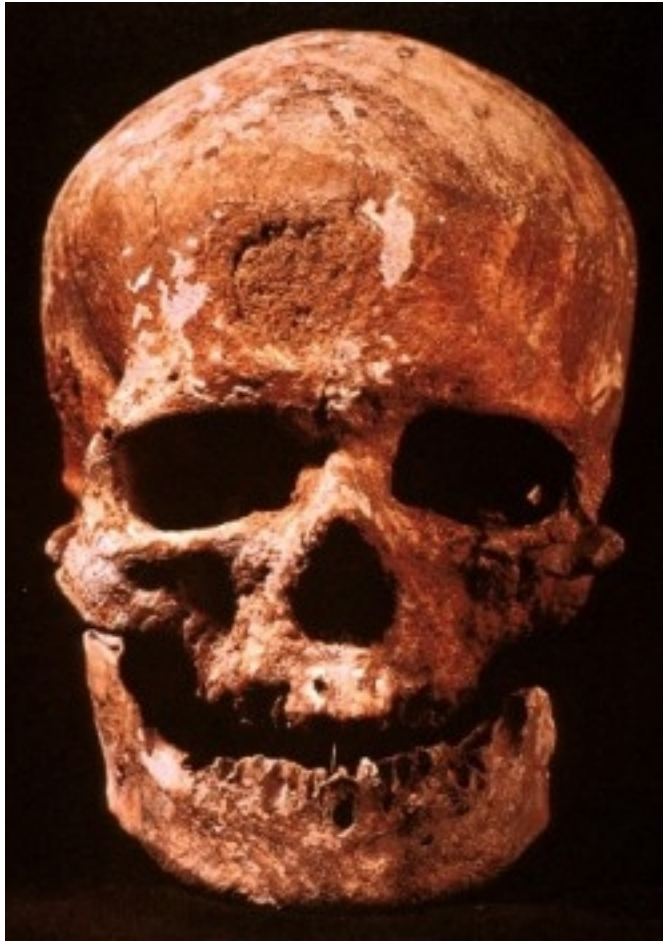

Possibly the most evolved human type ever to have lived on Earth: Crô-Magnon 1.

CENTRAL-ASIAN RED NORDID RACE (from now on, Red Nordid race or RN). The most abundant racial contribution among the primitive "ANE" (Ancient North Eurasians) described by modern population genetics.



This man, from Southern England, is a pure Red Nordid. Noticeable traits are orange hair, spare eyebrows, very dark-blue eyes and a completely red skin. Nose with a low nasal bridge and a fleshy tip. Squared features, prone to gain body mass. Notice a harder, broader, more robust and "en bloc" facial complexion than the White Nordid. If the WN inspires certain serenity, lightness and gracefulness, the RN inspires restlessness, impulsiveness, brutality, aggressiveness and explosive force, as well as a higher tendency to tyranny and abruptness. It is also a more passionate, less agile, less ethereal and more dense race than the White Nordid, with a stronger character and temperament, as well as more muscular strength. Presumably higher testosterone levels and more attachment to Nature—which could have driven them to develop natural medicine and body knowledge.



• **Stature:** Medium-low.

• **Constitution:** Massive and compact. Strong and broad bones. Prone to gain body mass (muscle or fat, depending on conditions). Short and powerful legs. Short, strong and wide neck.

• **Eyes:** Wide. Dark navy blue, small pupils, middle distance between eyes. Big sockets. Straight, horizontal, very sparse and almost white eyebrows. Less pronounced supraorbital arches than White Nordids.

• **Nose:** Shorter, wider, more rounded and in general, fleshier than the WN. The key of the Red Nordid nose is, in addition to its fleshy tip, that its "root" is not located between the eyebrows, but lower, so that it is "deep set" between the eyes. The nose has thus a less vertical, lower, more compact, aggressive and forward-projected appearance when looked from the side.

• **Ears:** Thinner and smaller than the White Nordid ones.

• **Mouth:** Extremely thin and narrow lips. Narrow philtrum. The outline of the lips is not clearly defined, nor differentiated from the rest of the skin, as in the WN case. Big mouth.

• **Teeth:** Lined-up set of teeth, smaller differences in height and shape than in WN. When mixed with Armenids, the separation between teeth tends to increase.

This can be due to the heredity of a big, spacious mouth which cannot be fully "filled" by Armenid teeth. Probably C-shaped dental arch.

- **Hair:** Orange, straight. Tends to stand up instead of falling.

- **Body hair:** Medium-scarce, although in mixes with Armenids, hair turns very dense, especially if some congisation is added to the mix. Bushy sideburns and goatee.

- **Skin:** In pure RN, the MC1R gene is deactivated, so unlike pure WN, they're unable to produce melanin. Very high levels of pheomelanin. Red, rosy and bloody skin. In mixes with other races, the bloody appearance tends to retreat to the face, and in the face, to cheeks, ears and under the eyes. People with a tendency to blush (be it of anger, heat or embarrassment), have RN contributions. Higher risk of skin diseases when exposed to the Sun more than they can tolerate, which is not much. This is because they descend from ancestors who almost never received sunlight exposition due to their necessity of protecting themselves from the cold with animal skins.

- **Skull:** Brachycephalic, flattened occipital bone, but prominent temporal bones. Larger cranial capacity and broader face than the WN race. This race has developed its cranial volume forwards (frontal bone) and sideward (temporal bones).



Pure Red Nordids have planoccipital cranium and this, in combination with the width of their temporal bones (temples) makes them the brachycephalic race *par excellence*, responsible for the cranial type previously known as "Alpine". Besides, they usually have strong nuchal muscles and tend to accumulate fat around the cervical (neck) area.

- **Face profile:** Very vertical, ultra progressive and very straight (orthognathous, very open-obtuse facial angle), more than the WN race.

• **Forehead:** Very high, straight and vertical. Again, more than in White Nordids.

• **Jaw & chin:** Strong, squared, broad and robust jaw. Prominent and sharp chin, which seems to end in a fleshy ball.

• **Other features:** Accelerated metabolism, very active blood circulation. Neoteny: very youthful look, whose freshness is even better preserved than in White Nordids. Tendency to perspiration and sweating.

Higher sensitivity to pain (see [here](#)). Redheads usually need more anaesthesia (about 20% more, though this can also be due to a faster metabolism) than the rest of persons. This fits well with the idea that the RN lost skin pigmentation and toughness by protecting themselves with animal skins, which ended up making their skin tissues look like subcutaneous tissues, losing their hardness. Other studies suggest higher sensitivity to thermal pain and lower sensitivity to electric pain.

Higher lactose and alcohol tolerance than any other race, what would lead us to think that Red Nordids were the first ones to consume milk and alcoholic beverages, as well as cattle meat. Here it is worth mentioning that what is now sold in supermarkets is anything but "milk" proper.

Freckles are not a Red Nordid inheritance, neither are they of any other pure race. They are common in Red Nordids mixed with Armenised White Nordids. We must remember that freckles (as well as spots) are little marks appearing due to higher eumelanin or pheomelanin concentrations. Fair-milky skin, unable to synthesize melanin, does not correspond with a pure racial type either, but with a mix Red Nordid + White Nordid, with a RN predominance.

Armenised RN have their orange hair get darker, turning to red and then auburn, while when mixed with White Nordids they have a sandy, somewhat flaming hair colour.

Green eyes are not an asset of any pure race either, but of mixes: green eyes are really low-pigmentation brown eyes (the same applies to amber eyes) mixed with grey and blue eyes. We have already seen that green corresponds to a "little active" *OCA2* gene, while blue and especially grey, are the result of a "deactivated" *OCA2*.

• **Paternal lineages (Y-DNA):** R (R1a, related to Slavs and Aryans, and R1b, the predominant haplogroup in Western Europe). R2 is also probably Red Nordid in origin. There is a possibility that all these lineages are Armenid. In such case, other possible candidates to paternal RN lineages are I2b1 and G.

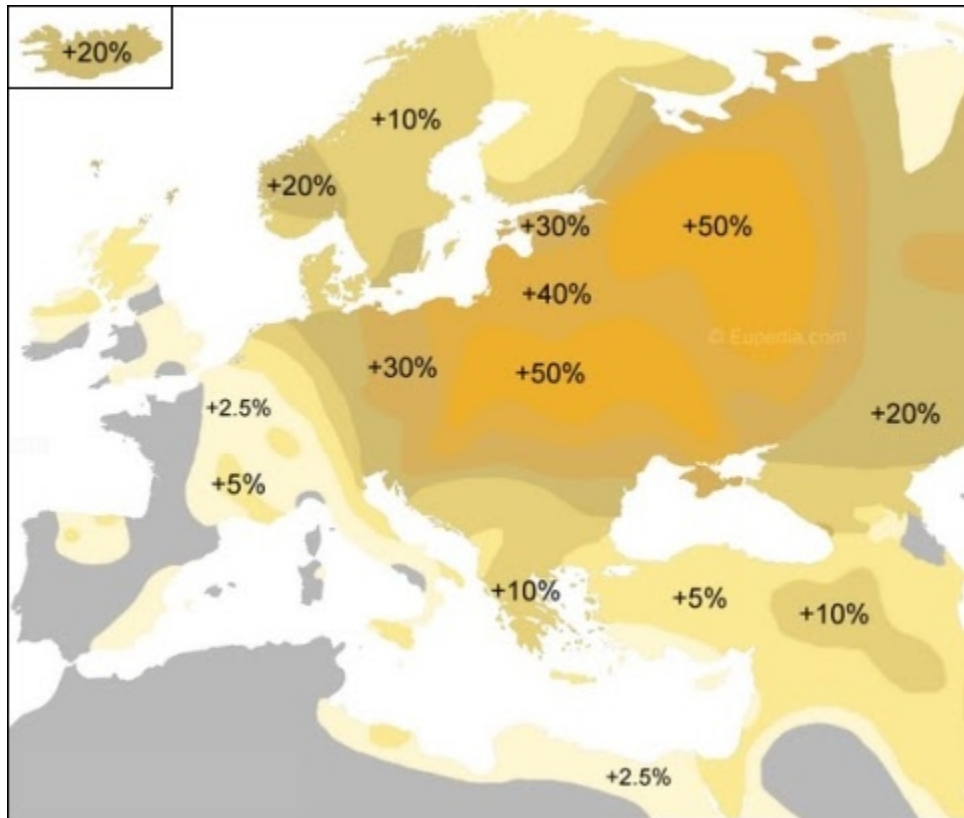

Distribution of the R1a lineage, the most common in Eastern European countries. This haplogroup, whose European peaks seem to be located in the *Urheimat* of the Slavic tribes, is also clearly related to the Aryan invasions. Source: Eupedia.com

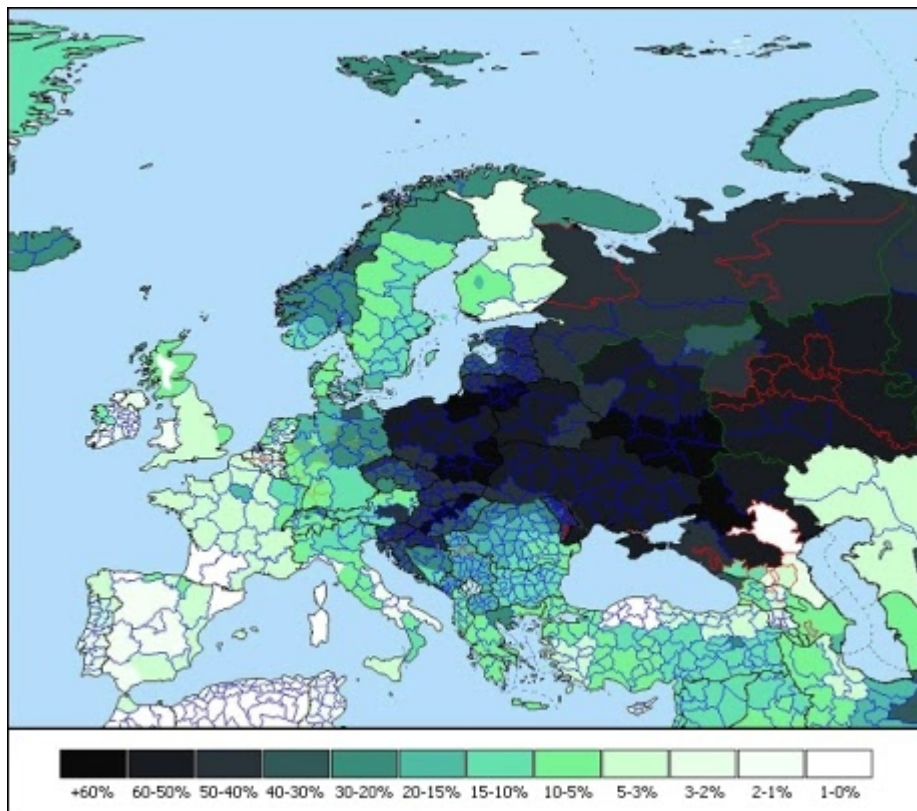

Lineage R1a frequency per regions —linked to Slavic and Aryan tribes. Notice that the largest concentrations of this haplogroup occur in places like Poland, Ukraine, Belarus and Russia, considered the *Urheimat* of the Slavic peoples. There is an abrupt decrease in R1a concentration in countries (Serbia, Bulgaria) that, despite being of Slavic heritage, came into contact with other tribes (Illyrians, Byzantines, etc., while Thracians and Dacians were probably of I stock) and lived under the Ottoman Empire. In this context, see the difference between Croatia and Bosnia, or between Ukraine and Romania. The few R1a contributions in Spain may have come along with the Alans and with the later Slavic mercenaries employed by the Córdoba Caliphate, as well as with Moors with Persian heritage, at least on their father's lines. Another interesting detail is the R1a frequency in countries like Syria or Iran, which were under Persian dominion and therefore received a significant Iranian flow.

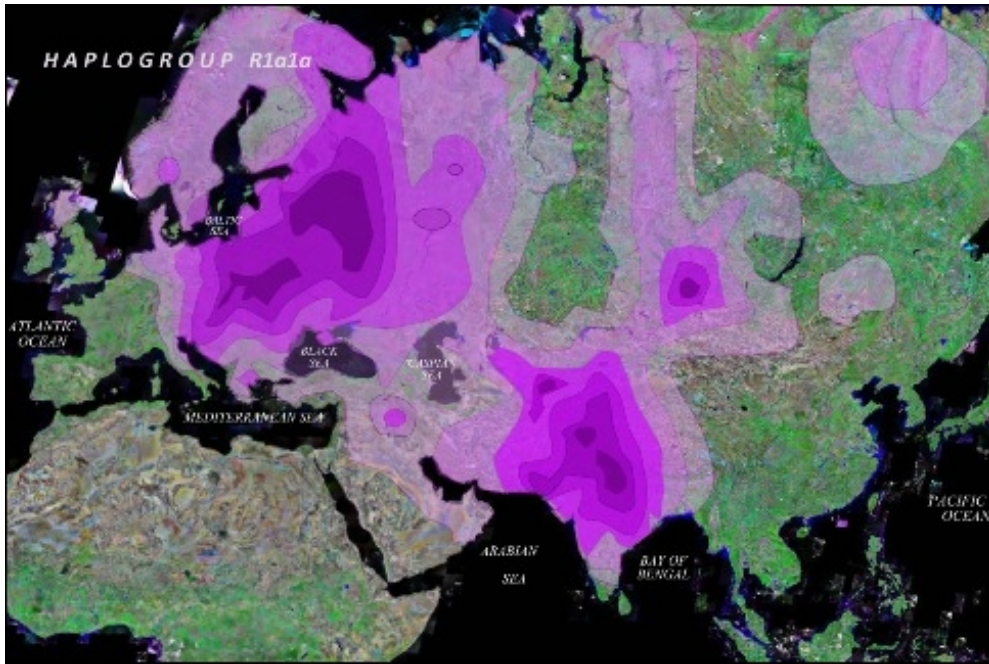

R1a distribution in Eurasia. The highest R1a concentrations are to be found amongst the Brahmin castes of some Northern Indian regions.

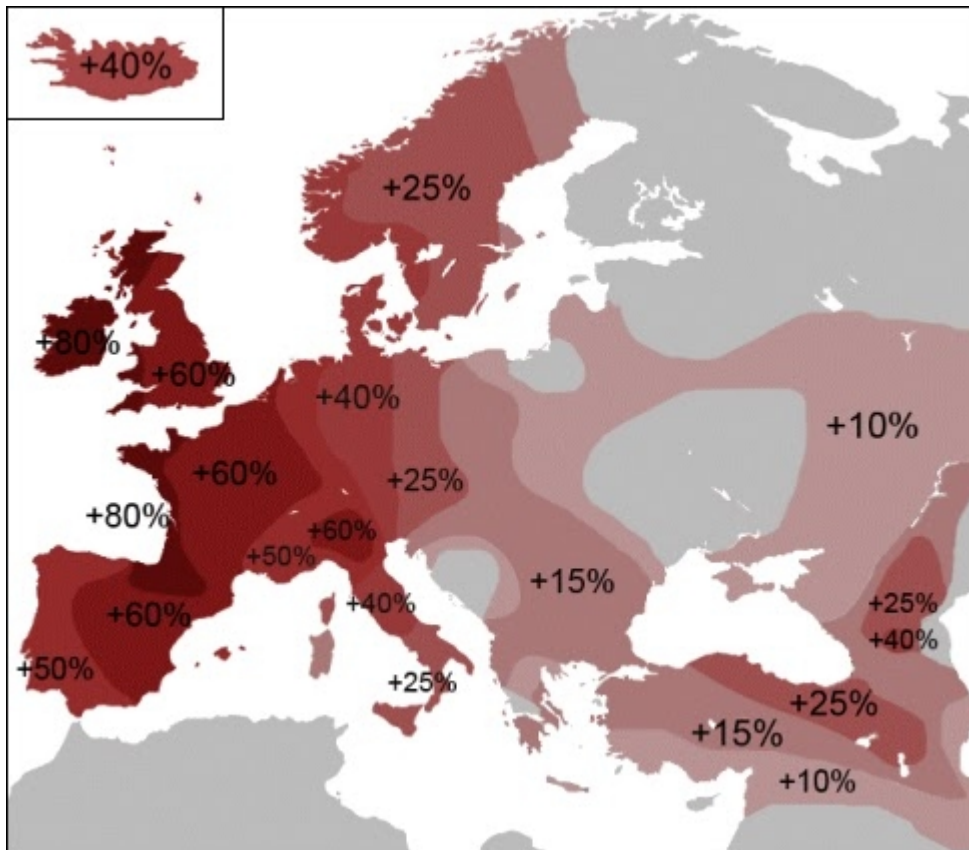

[Click to enlarge](#). R1b distribution in Europe. Source: Eupedia.com

• **Maternal lineages (mtDNA):** HV, H, V. Probably not all HV descendants are Red Nordid, many of them can be Armenid.

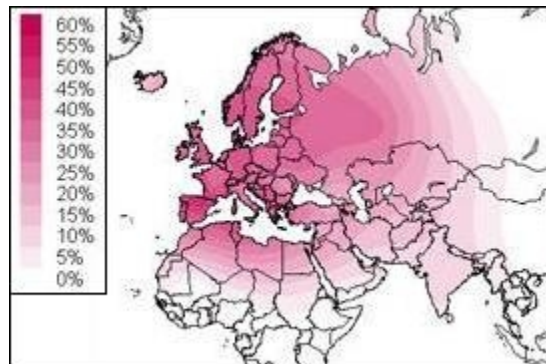

Approximate maternal H lineage distribution. Radiating from Spain, this haplogroup gets gradually lost as we move southwards and eastwards from the Iberian Peninsula.

• **Spirituality:** Connected to Nature. Fire cult. Worship of the spirits of water, air, fire and Earth. Plenty of "phallic" constructions related to heavenly bodies. This race seems more gifted for esoteric and "magic" issues than the WN. Gods of the Earth, vegetation, waters, homes and families.

• **Psychology, idiosyncrasy and racial character:** Love for Nature, patriotism, attachment to the homeland, intelligence, impulsiveness, unpredictable personality, prone to fits of fury and sudden uprisings, proclivity to excesses in violence matters, but also to overwhelming joy. Traditional Western medicine considered redheads as "blood" tempered individuals, whereas the ancient Indian Ayurvedic medicine describes them as being Pitta types (associated with fire; this also proves that ginger hair was not unknown in India and that there were redheads during the Indo-Aryan migration). Strength, roughness, fierceness, very developed character, individualism, strong temperament, good memory. This is doubtlessly the race of passion, fire, anger, extremism and even of some cruelty.

A more noisy and Dionysian personality than the White Nordids, which is one of the reasons why Spaniards usually say that they fit better with the Irish (which have a great Red Nordid heritage) than with populations with a larger cultural and genetic White Nordic imprint that are more serious —like Englishmen, Germans or Scandinavians.

On the basis of evidence in archaeological sites and mummies, as well as descriptions of Scottish Picts (which were probably of Red Nordid heritage), it seems this race was inclined toward tattoos (even in the face) and corporal paintings, utilizing a blue pigment called "woad" in Scotland.

• **Distribution:** This race has its purest stronghold in Scotland and Northern England. In Spain, from a physical-anthropological point of view, the purest R1b-Red Nordid core is located in Navarre and sub-Pyrenean areas of Aragon. There is not a known pure R1a core as happens with R1b.

As a matter of interest, the distribution and abundance of redheads could be vaguely related to blood types 0 and -Rh, frequent in Western Europe and decreasing the further eastwards we move.

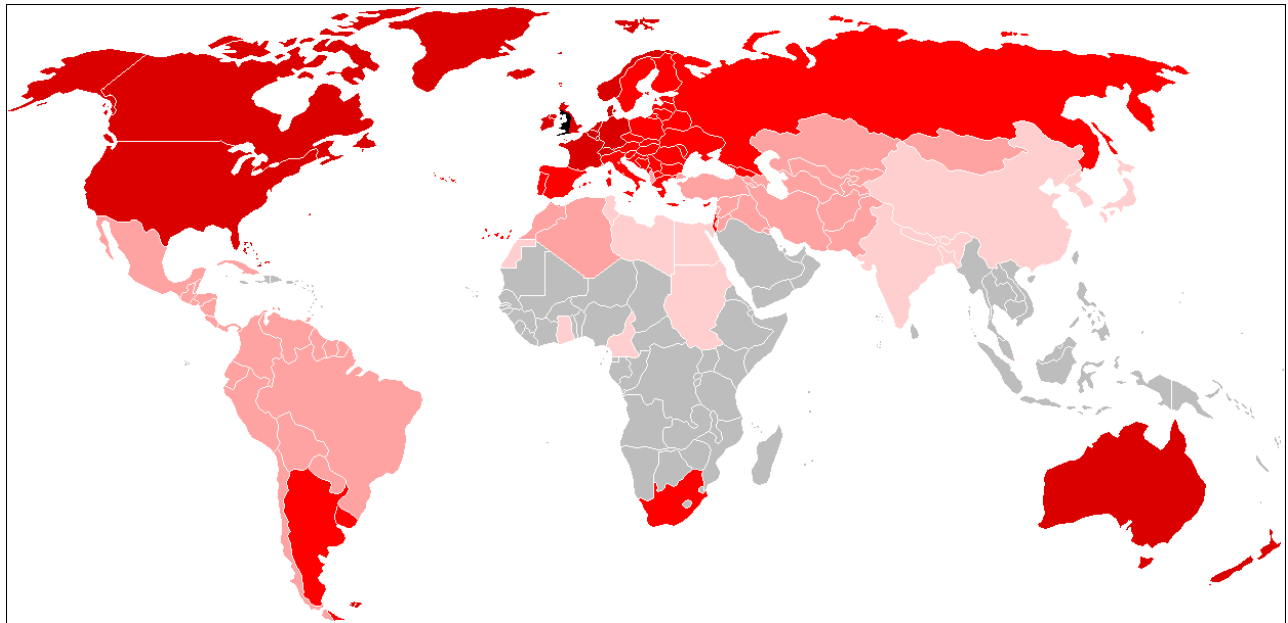

Red Nordid traits distribution per country. Countries with larger quantity and/or purity of Red Nordids are darker. White Nordid distribution is pretty clear and needs no further explanation, but this map does require it. First, there are also deep RN infiltrations in Africa. For instance, in Northern Cameroon there is an extraordinary quantity of paternal R1b lineages, although they are obviously (as in the case of mixed South Americans) extremely mixed. Second, and probably most striking, is the presence of Red Nordid genetics in Eastern Asia, but it is not so hard to believe if we remember the tendencies that some of these populations have towards fair skins and blushing, especially Japanese, Manchu, Uyghur and Korean types, in opposition to Vietnamese and Cantonese types. And third, we must also remember the cases of red-haired mummies found in China —which confirm an ancient European penetration in that land — and the presence of ancient R1a lineages in Western Mongolia. More information about these issues can be found in the article on [Central Asia](#).

• **Brief history:** The Red Nordid race is probably around 50,000-30,000 years old. For the moment, it seems clear that the R haplogroups stem from on or two Armenid lineages by mutation and evolution (see chart in the "Evolution of

lineages" section). Most likely, the glacial mountain ranges in Central Asia (e. g., Altai, Hindu Kush, Tien-Shan, Pamir, Kunlun or Sayan) acted as natural barriers, blocking reproductive communities who were escaping southwards from the cold, and thus imprisoning them in a confined geographic pocket with a tremendously hostile climatology, though with excellent hunting game.

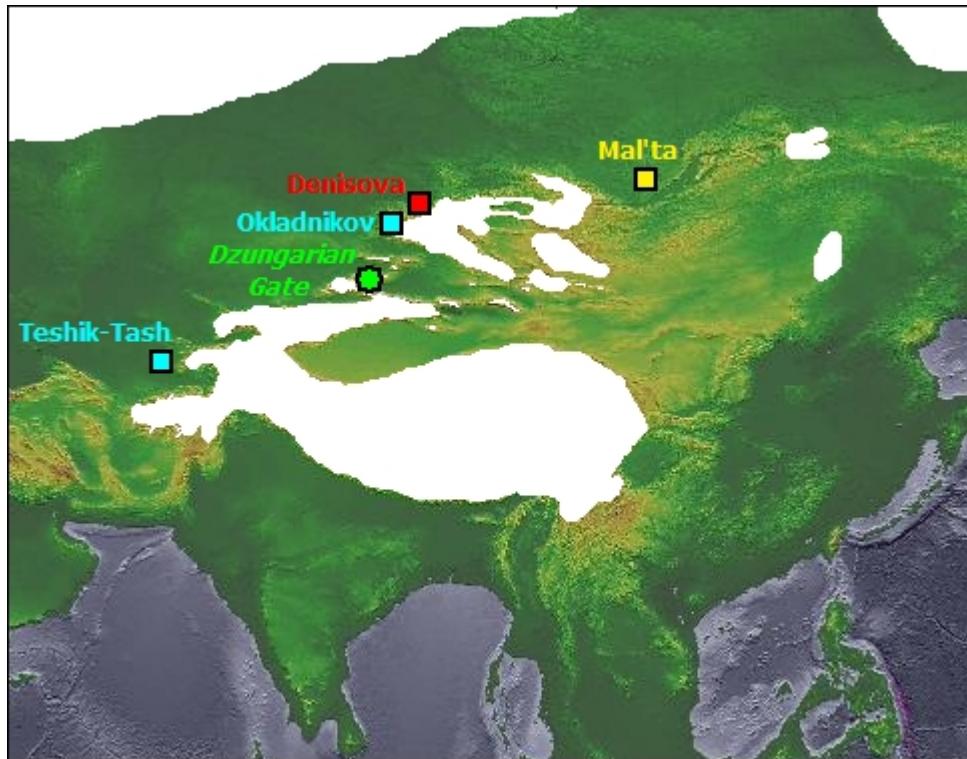

This is how Central Asia must have looked like during the last glaciation. To the North, conditions were harder and harder until stumbling upon the polar cap. To the south, the retreating path was blocked by mountain glaciers. In this geographical pocket, the Red Nordid race was probably forged. As orientation, the Okladnikov and Teshik-Tash sites (Neandertal) are marked in blue, the Denisova (Denisova hominid) in red and the Mal'ta in yellow.

From the Armenid P haplogroup, the Q as well as the R haplogroups derived. Such lineages originated in Siberia-Central Asia, from where the Q headed eastwards until they crossed the Bering straight and colonized America. The R ones headed south and westwards and gave rise to the R1 and R2 haplogroups (around Afghanistan). R2 remained in India, while R1 split into R1a lineage (towards the steppes of Southern Russia) and the R1b (towards Mesopotamia).

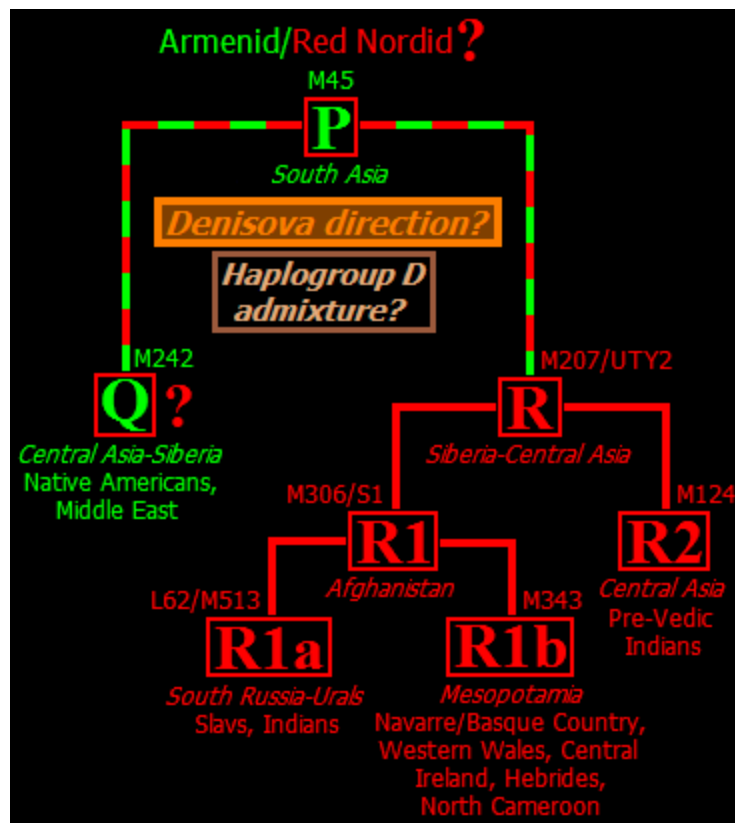

Y-DNA phylogenetic tree of the Red Nordid race. It is hard to determine with certainty which was the first RN haplogroup, though it was probably R. If it was P, the Q haplogroup would also be Red Nordid and the armenisation and mongolisation would have appeared later due to mixing. It is also possible that these haplogroups were originally "pseudo-Red". Valg considers G to be another possible candidate to RN lineage. We leave open the question mark as to whether the Denisovan hominin had something to do in the conformation of the RN racial type. The same can be said about the Central Asian Neandertal race. Another interrogation is the apparent physical-anthropological link between Red Nordids and certain ethnic groups carrying the D haplogroup (Andaman Islands, Ainu, Tibet, we will see this in a future article) that suggests a possible genetic interchange in the distant past, before the rise of the Red Nordid race.

R1a spread through the Russian steppes and Eastern Europe, creating pastoralist societies like Yamna (or Yamnaya), Poltovka and the Volga battle-axe culture. Subsequently, the Sintashta-Petrovka and Andronovo cultures will spring up. Afterwards, with the Aryan invasions (and already with White Nordid and Armenid contributions), the R1a societies will expand through the Middle East and other regions of Asia. R1a is associated with Slavic, Aryan and Indo-Aryan populations. The [Seima-Turbino Phenomenon](#), peoples who extended from Finland to Mongolia, who used chariots, practised husbandry and horse riding and hadn't developed agriculture yet, are associated to this lineage.

R1b's history is rather more complex. After its long journey across the Middle East, R1b carriers entered a stalemate in Anatolia, where they did not enjoy much success (competence with T, J, E lineages was probably already intense), so they crossed the Caucasus and entered Eastern Europe and the Danube corridor. The Bell Beaker culture is probably one of the first manifestations of the RN race in Europe. The former hunting territories of the Cro-Magnon communities (except for maybe those of the Bosnian-Croatian zone) were deserted: the White Nordid race, identified with Cro-Magnon man, the archaeological Magdalenian culture and I1 haplogroups, had moved north with the thaw. R1b, thus, occupied the Franco-Cantabrian pocket (probably also another Central European one, from which the Halstatt culture and the Celts arose, already with WN and Armenid contributions) and subsequently settled all Western Europe, coming into contact with White Nordids and mixing with them.



The "glacial refuges" theory. According to it, R1b rose in northern Spain, I in the Balkans and R1a in Southern Russia, and all of these populations simply moved north during the deglaciation, colonizing all Europe. This theory has become obsolete. Below, explanations on the origin and migrations of R1b.

Mixed with White Nordids and Armenids, the Red Nordid blood was present in the formation of [India](#), [Persia](#), Greece and Rome. Its heritage is to be found in distant areas such as Eastern Siberia, Mongolia (Genghis Khan was a redhead with blue eyes, significant amounts of R1b and [Red traits](#) in present day Mongolia), China (red-haired mummies, residual Red Nordid traits in many modern Chinese), North America (the si-te-cah, previous to the arrival of the later "mongoloids"), South America (red-haired mummies) and even the Easter Island (documented by Thor Heyerdahl).

• **Present context:** The Red Nordid race corresponds to the hefty, short, brachycephalic and ruddy human type. They are known as daring people, with a strong temperament and prone to outbursts and impulses in general. The Red Nordid heritage is well known in Scotland, Ireland, Wales, England, United States, Canada, Norway, Australia and New Zealand. There is much Red Nordid blood in Spain, yet it is rather more diluted than in the previously mentioned places. Even though, cases of men with reddish shades in the beard are very common. The same happens in all the Middle East. It can be said that this race constitutes the foundations of the Celtic heritage nations in Western Europe. The purest Red Nordid core is to be found in the British Isles, Norway, Iceland to a lesser extent and the countries (United States, Canada, Australia, New Zealand) who hosted people coming from these lands.

REFLECTIONS ON THE RED NORDID RACE

At present times, a racially pure individual is always very striking, no matter which race he belongs to. However, the ones who stand out the most are the pure Red Nordids, with their orange hair, bright red skin, corpulence and incandescent appearance. It is very significant that the glacial ices gave rise to a fiery human type, so I will provide some ideas about this peculiar race.

1. "The" Nordic race *par excellence*

(Note: Valg does not consider the Nordic origin of the RN an absolute certainty). It is impossible to locate ourselves in the RN race context if we don't think about the environment they inhabited. We are talking about Central Asia (Southern Siberia or ex-Soviet republics) during the Würm Glaciation, that is, similar conditions to present day Greenland, yet with a strong continental

environment as an aggravating factor (the geopolitical Heartland of Eurasia, the geographic centre furthest from any coast, especially during the ice age, when the sea level was 120 metres - 400 feet below the present level). Under these conditions, having the slightest patch of melanin was probably the worst of curses. In plain language, this race has a hard time with heat and sunlight. It must be emphasized that the Red Nordid race is "more Nordic" than the White Nordid. This variety either lived longer under Arctic conditions, or the conditions (probably Siberia, Central Asia) were tougher than those suffered by the WN (Europe). Red Nordids represent cold adaptation taken to its extreme. Thus, the White Nordid race is in many aspects between Armenids and Red Nordids. For instance, the WN haven't got such a prominent jaw, nor such a strong skeleton, nor such spare eyebrows, nor certainly such a short stature, as the RN race. Also, WN were in the process of eumelanin-depigmentation (they are still able to get a tan), but the RN are directly unable to produce melanin and, instead, they have extremely high levels of pheomelanin.

2. A reduced, decimated and isolated clan

An important idea we have about this race is that, in its origin, it must have been made up by an extremely reduced community, maybe about a few hundred individuals, highly bonded to each other, geographically concentrated, constantly hounded by the elements and thus were about to perish in many occasions, so that everyone had to pay the terrible toll imposed by the cold, some with the death of their lineage and some with a permanent biological adaptation to the new conditions.

Because of their current complexion, it is reasonable to think they spent most of the time inside shelter-caves (legends about subterranean cities or Shangri-La, found throughout Central Asia, like Shamballah or Agarthi, could come from this), and that they developed great muscular strength and a tradition of toughness, stubbornness and relentlessly facing the elements and all kinds of adverse conditions. Likewise, Red Nordids are well adapted to alpinism.

This constant harassment by the environment must have sharpened their inventiveness to manipulate the means at their disposal, preparing them for the advent of technology. It is also likely that the first Red Nordid community, after its formation, did not meet individuals from other ethnic groups in tens of thousands of years, again in contrast with Cro-Magnons, who surely came into contact with

other racial communities (by interbreeding and fighting), as it was a more geographically scattered race than the Red Nordid.

3. The ills of the thaw

The deglaciation must have had a very remarkable effect on the Red Nordid race. It was not only the climate change, but also that many RN clans (especially R1b) started to settle regions (Middle East) where the environmental conditions were radically different to those they were adapted to, in contrast with the White Nordid I1 branch, that moved northwards. Due to their vulnerability to warmth and sun, we believe the Red Nordids to be the first ones who used clothes that covered their entire body, including their faces, as well as garments intended to protect them —e. g. turbans and veils.

Similarly, milk and alcohol consumption and the subsequent introduction of cereals (an inferior food compared to the hunter-gatherer diet, and whose adoption responded to the requirements of overpopulation and/or hunger) and the sudden rise in temperature (not only because of the deglaciation, but also due to the movement of these communities to southern regions) brought about obesity, a very common illness among Red Nordids, though this characteristic tends to get out of control with racial mixes. Cold consumes many calories and this race was adapted to a plainly gelid environment, where the accumulation of a moderate amount of fat helped them to survive. When cold stopped, all those calories remained unburnt, and when we add starchy foods with a high glycemic index, alcohol and racial mixing (not to talk about the new sedentary lifestyle) to the equation, obesity is the result. We have to bear in mind that the human being is made to obtain most of his energy from fat. This is particularly true in the North, where animal fat intake must have been through the roof. When starches substituted fat and natural sugars (e. g. honey, fruit or wild berries) as the main energy source, the immediate effect was that the body lost the capacity to burn fat. High insulin levels (at the expense of growth hormone, which promotes fat burning apart from skeletal and muscular consistency), insulin resistance (and other related ills, such as diabetes) and obesity, were the inevitable result of this bad step, particularly in those reproductive communities who were most adapted to burning fat as their primary energy source.

The psychological imbalance produced by subjecting this people to mild temperatures can not be underestimated either. They started protecting themselves from the cold, and then ended protecting themselves from the heat.

They did well in occupying Europe, but this race will never achieve inner balance and harmony unless under strong Arctic conditions, where snow rarely disappears. Canada, Iceland, Greenland, Northern Scandinavia, and Siberia, as well as the extreme South American Cone, would be the most suitable regions for them and even so, this is probably not even close to the Siberian conditions of the Würm Glaciation.

4. Medicine and body alchemy

Red Nordids are probably the main ancestors of yoga, magic, sexual metaphysics and inner cultivation systems. In India, these issues are previous to the Indo-Aryan invasion, which could mean they date back to the R2 lineage, which, together with the L lineage (probably Armenid or pseudo-White), led the development of the Indus civilisation before the arrival of the Aryans (who carried the R1a lineage, but already had significant White Nordid contributions, acquired in Eastern Europe). The original Red Nordids might have developed these methods (especially breathing control, breath retention and cellular respiration) in order to generate inner heat in that cold environment, as well as to prevent their body from stiffening up and atrophying due to joint damages and the lack of flexible and fluid movements (in Europe, Cro-Magnon probably kept these functions fit thanks to the intense activity he naturally had in his daily life, though it should not be ruled out that he also had his "tricks"). This tradition, gathered during millennia, is probably the origin of the detailed knowledge about the human body and spirit that certain Eastern religions (Taoism, Hinduism or Buddhism) display.

Because of the deep body awareness and consciousness that this presumably implied, Red Nordids could have acquired important medicine knowledge and, at present, they seem to manifest an innate inclination towards this kind of discipline. The connection of Red Nordids with medicinal and "magic" systems might have echoed in Medieval Europe, where redheaded women were considered to be more prone to "witchcraft" than the rest.

5. Neolithic, Civilisation and the Great Mother

Now it seems evident that the journey of the R1b lineages throughout the Near East played a crucial role in the expansion of Neolithic. The overlay of a Red

Nordid social stratum over an older Armenid (and Congid, Mongolid, etc.) one, could have been what gave rise to civilisation.

A sign that hints in this direction is the Göbekli Tepe sanctuary, a complex built by a hunter-gatherer society in present-day Turkey 11,000 years ago, and thus before the appearance of agriculture. Human representations found there (statues and statuettes) seem to depict an essentially Red Nordid tribe. That would confirm the presence of R1b lineages roving through the Middle East before entering Europe.



This statue found in Göbekli Tepe and sculpted about 11,000 years ago by hunter-gatherers, has Red Nordid features, like planoccipitaly. A little Dea Mater (the well-known fat Mother-Goddess) [statuette](#) has also been found, that displays some Red Nordid traits.

Although the *Magna Mater* or Great Mother is a religious archetype that sinks its roots in the Palaeolithic times (including European palaeolithic), the RN race could have been particularly devoted to the Mother archetype.

6. The problem of the Red Nordid ancestors

In the same way that Cro-Magnon is related to the WN race and the Eastern Neanderthal with the Armenids, it could be plausible and not to discard that the recently discovered Denisova hominin (South Siberia), or some other Central Asian hominid, could have something to do in the development of the RN race. Central Asia was inhabited by different hominid types (Denisova, Neanderthal, Sapiens); a certain degree of crossbreeding must have taken place. The problem of finding precursors of the RN race is the region, extremely vast and scarcely populated and explored. In densely populated Western Europe, archaeological sites are frequently found (many of them, like Atapuerca, by sheer chance). However, Central Asia is an immense region, badly communicated, barely

populated, hardly civilised or built up (and therefore hardly excavated), full of geopolitical instabilities and conflict threats. Moreover, we are talking about a race that probably lived strongly bonded and gathered, so that the number of sites must be very reduced.

Because of this, the archaeological remains of the Red Nordid ancestors haven't yet been found, but if researches direct their efforts towards Siberia and Central Asia (like the team that found the Denisovan hominin in the Altai mountains did), most likely they will find these remains sooner or later. The "Shangri-La" or sites belonging to this race must be between the former polar caps limit and the northern face of mountain chains such as Altai, Hindu Kush, Tien-Shan, Pamir, Kunlun, Sayan and the so-called "Kazakh Shield" among others. This yields territories belonging to Siberia, Kazakhstan, Mongolia, Xinjiang, Tajikistan and Kyrgyzstan, and the sources of rivers like the Irtysh and the Ob. We could also consider the *Sibirische Tasche* (palaeolithic Siberian pocket) that anthropologist E. F. von Eickstedt talked about. The Chinese region of Dzungaria —confined in mountain ranges and separated from Central Asian plains by a narrow passage (the [Dzungarian Gate](#) or Alatau Pass) that must have been blocked during the glaciation— is another possibility. As happened in Europe, the mentioned mountain ranges would have acted as natural barriers, forcing the Red Nordids to remain in high latitudes and evolve.

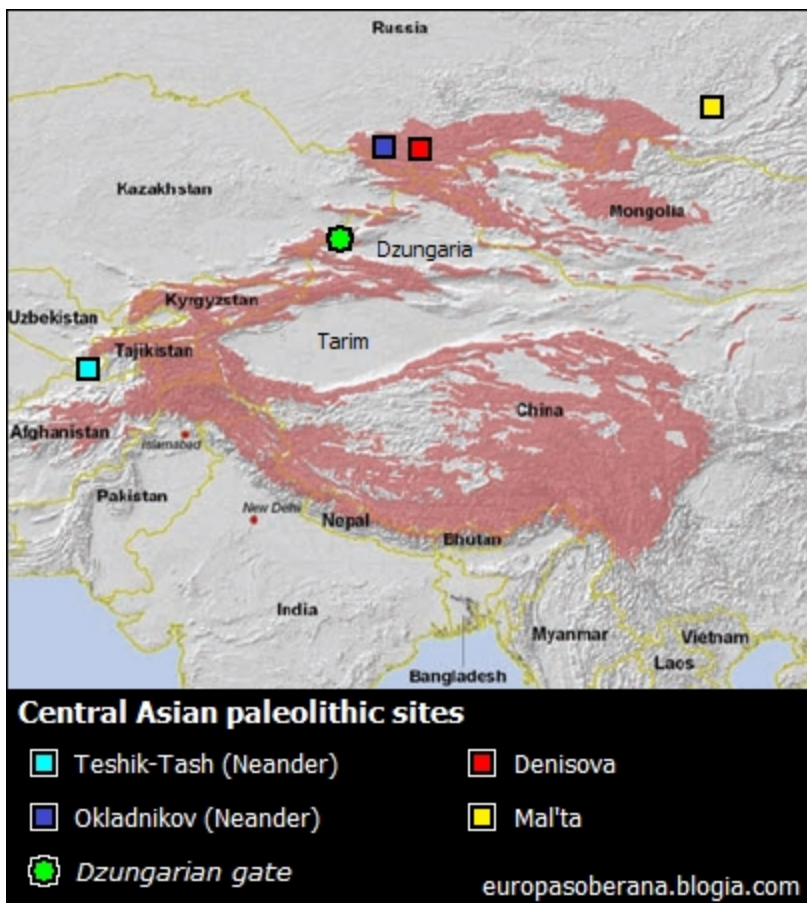

This map displays the present-day geographical particularities of the region we have referred to. During the Palaeolithic, many pockets formed in this area which were blocked in the North by the polar cap and in the South by the numerous mountain ranges. They could have trapped human reproductive communities, forcing them to adapt or perish. Red Nordids could be the survivors of this evolutionary alchemy. The Dzungaria region, that must have been completely surrounded by a glacial ring, could have been one of these pockets.

7. Stockbreeding

The areas with most Red Nordid racial contributions (Ireland, Scotland, Wales, Basque Country) have high lactose tolerance frequencies, which fits well with the possibility of them being the first race to practice stockbreeding and pastoralism. In the Basque Country, 91,7% of the population is [lactase persistent](#) (mutation -13,910*T of the *MCM6* gene), and in Ireland, the percentage is 96%. The European zones with lower rates of lactase persistence are Sardinia, Greece and Southern Italy. Red Nordids maybe developed lactose tolerance after incorporating it to their diet for a long time, or maybe it was already part of their genetic pool for some other reason. We should remember that lactase persistence is actually a neoteny (youth conservation) trait, as digesting lactase is

undoubtedly a childish trait, and that Nordic races, especially the Red, fit well in this profile. It's interesting to verify the symbolic role of the aurochs and afterwards of the cow and the bull, in Red Nordic cultures, like some Near Eastern Neolithic societies (Çatal Hüyük), the Indos, Hindu civilisation, Persia or even Spain. In Central Asia (where herding probably originated), the yak is the main character of this tradition.

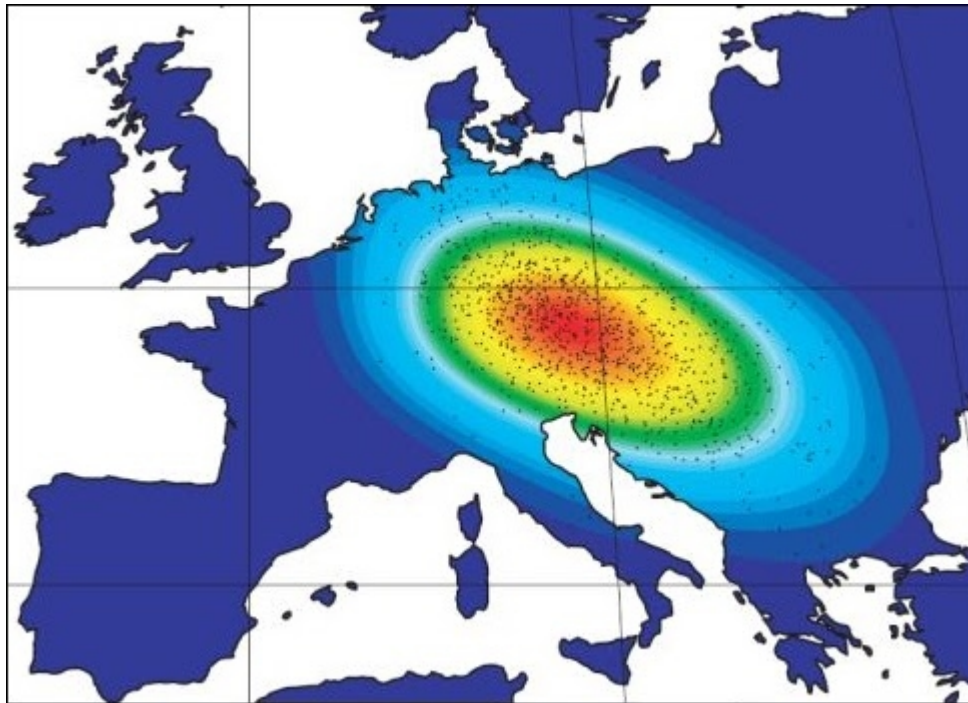

Development of lactose tolerance in Europe. It corresponds with the original core of certain Neolithic cultures such as Linear Pottery, Bell Beaker (inhabited by brachycephalic and heavily built people) or Unetice, and afterwards, age-of-metals cultures (Tumulus, Urnfield, [Halstatt](#), La Tène). In these societies, considered precursors of the Celtic-Italic world, cattle, mining, metallurgy, and salt were very important. While these societies thrived, the indigenous populations of Europe, identified essentially with Scandinavian communities, were [not yet lactose-tolerant](#). The high lactase persistence that some I1 peoples (like the Swedes) manifest today, was probably acquired by intermixing with Red Nordic peoples.

In Asia (except in Central Asian steppes and in Tibet and Mongolia, where it's normal to drink the milk of mares, camels and yaks), the lactose intolerance rate is around 50%, mounting to 100% in some zones. Africa (with exceptions such as Saharawi and Masai) and the native populations of the Americas, have also very high lactose intolerance rates.

In the First Neolithic of the Near East, agriculture and pastoralism are never found together: agriculture appeared in Israel and the [origin of herding](#) and

pastoralist cultures seems to be in the Zagros Mounts and Upper Mesopotamia. Afterwards, in the first Mesopotamic civilisations, stockbreeding was distinguished from agriculture and was related to predatory mountain-folk and leadership traditions: kings saw themselves as shepherds of peoples and tribes. This tradition is still perceived in the Jewish Talmud, where cultivating the soil is seen as a lowly occupation.

8. Agriculture?

Considering the Eastern origin of Red Nordids and [some studies](#) that link R1b with the expansion of agriculture (not necessarily with its origin), Valg defends the theory that RN, apart from being responsible of stockbreeding, are also responsible of agriculture. I do not share this point of view, due to the clearly ethnic distribution of **celiac disease-gluten intolerance**, which I further develop in the article on the [dietary damage](#) done by the Neolithic revolution, together with the separated origins of agriculture and stockbreeding. The mentioned disorders are a symptom of rejection to cereals, especially wheat, and their frequency in Ireland (at least 1%) and in Scotland is so high that in the United States, it is called "Celtic disease". After the Celtic regions, the highest levels of cereal-related intolerance are found in Scandinavia. The lowest levels are found in Greece, specifically in Thessaly, that hosted the first Neolithic cell of continental Europe (Sesklo-Dimini sites) and was the gateway for agriculture in our continent. At the same time, Greece and Southern Italy are the European regions with a higher occurrence of lactose intolerance. Celiac disease is related with the presence of some *DQ* genes, especially with *DQ2.5*. This gene reaches its highest frequencies in the Basque Country and Ireland.

Another interesting issue is that the capacity to process cereals seems to be related with the amount of copies of the *AMY1* gene. The highest number of *AMY1* copies seems to culminate in Eastern Asian populations with a rice-based diet. These populations are also highly lactose intolerant.

If at the beginning of the Neolithic agriculture and stockbreeding never appear together, then they were practised by different peoples. If RN are lactose tolerant but cereal intolerant, regarding them as the first stockbreeders would automatically rule them out as the first agriculturalists. Celiac disease cases are only the tip of the iceberg; they imply that a much large percentage of the population would actually improve their health if they kicked gluten out of their diets. The obesity Red Nordids tend to is a clear symptom of rejection towards the

modern diet, strongly based in starches, hydrogenated fats and refined sugars. The idea of RN being the first in systematically cultivating and massively consuming cereals is in flagrant contradiction with them being the population with the highest levels of gluten intolerance and celiac disease in Eurasia and both Americas.

9. Other ideas

- Red Nordids probably inhabited even colder regions than White Nordids, so they must have been even more dependant on hunting. They must have been perfectly adapted to processing large amounts of animal proteins and fats coming from Central Asian megafauna such as mammoths and giant unicorns (*Elasmotherium*).

- The need of protecting their skin from the cold sabotaged their capacity for synthesizing Vitamin D, and also made their skin lose its functionality. In order to produce Vitamin D and obtain calories to generate heat, they must have depended on dietary sources rich in animal-origin saturated fats. The broadness of the RN skeleton bears witness to the success of this strategy.

- The first evidence of alcohol production could date back to the Natufian culture (present-day Israel), where cereals were harvested, allegedly to feed cattle and brew beer rather than for direct human consumption. Nevertheless, it is plausible that alcohol was already produced during the Palaeolithic, fermenting certain herbs, honey, fruits or wild berries —in such a case, Red Nordids must have been the greatest consumers, otherwise they wouldn't presently be the most tolerant race to alcohol.

- Because of the cold and dry environment they probably inhabited, and because of the need of warm and humid air from time to time in order to hydrate and clean the respiratory system, Red Nordids might have been the creators of the first forms of sauna, which might have simply consisted in evaporating water over hot stones in closed rooms located inside caves or shelters.

NEAR EASTERN ARMENID RACE (from now on, Armenid race). The most abundant racial contribution among the primitive "EEF" (Early European Farmers) described by modern population genetics.



This individual, an ethnic Armenian from Syria, is a pure Armenid. The German anthropologist Hans F. K. Günther bequeathed us (*"Rassenkunden Europas"*) this exceptional photograph of a human type he called "Armenoid" or "Hither-Eastern", and that Valg prefers to call "pure Dinaric". Wedged profile shape, receding forehead, huge nose with a very high nasal bridge (almost at the eyebrow's height), weak jaw, receding chin, dolichocephalic, high cranial vault, gracile physical constitution. This type is opportunistic, also astute, dreamer, nervous but calculating. In Europe, such pure types probably no longer exist (certain regions in the Balkans and Italy would be the purest European cores), but the great majority of us are "armenised" to a larger or lesser extent.

- **Stature:** Medium-low.

- **Constitution:** Slim, gracile. Resistant to scarcity. Extremely fibrous, lean and vascular.

- **Eyes:** Brown, medium-sized pupil, short distance between eyes.

• **Nose:** Big, tall, aquiline, narrow, "sharp" arch. As has been said before, one theory is that natural selection shaped this race's nose in order to dampen the dry desert air before introducing it in the lungs, while another valid theory is that they developed larger nasal passages to increase oxygen intake in a mountainous environment with rarefied air. The latter is more probable, as during the last glaciation, the Near East was not a desert zone. We thus see that the big and aquiline nose is not exclusively Jewish or Semitic, but due to armenisation, independently of its origin (the typical Semitic "hooked" nose is wider and fleshier due to RN and Congid influence). Were it not for the influence of the Armenid aquiline nose, many "Mediterranean" types of Southern Europe would have snub Congid-like noses.

• **Ears:** Large. More elongated and rounded than either Nordic varieties. Tendency to stick out.

• **Teeth:** Small mouth, narrow set of teeth and irregular outline (differences in heights and shapes of each tooth). Probably the shape of the "bite" or dental arch tends to look like a V.

• **Hair:** Black, thick, bushy, and straight-wavy, probably quite greasy. Curly hair is due to Congid influences. Tendency to receding hairlines in the top corners of the forehead.

• **Body hair:** Very bushy moustache.

• **Skin:** Light brown. Clean and uniform appearance. *MC1R* gene active, tendency to suntan.

• **Skull:** Armenid-type dolichocephalism. Higher and more vertically-oriented curvoccipitaly than that of White Nordids, it is the typical dolichocephalism of the "gracile Mediterranean" type. Very high cranial vault. This race has developed cranial capacity upwards and backwards. As happened with Neandertals, the receding forehead was compensated by a voluminous parietal region.



Egyptian Pharaohs Ramesses II and Seti II. Despite having other racial influences (for instance, Ramesses was a redhead), they can be described as of Armenid racial base. They display the typical elevated Armenid curvoccipitaly, that makes the neck look longer.

• **Face profile:** Shape of a wedge with its tip at the nose. Rat- or shark- like profile, primitive-ish. Forward projection of central parts of the face (nose) and receding peripheral parts of the face (chin, forehead, but also regions in the horizontal axis, like cheekbones and zygomatic arches). If the Armenid face is placed looking upwards, the shape would be similar to that of a cone with its apex on the nose tip. For this reason, the Armenid's wedged shape can not only be seen from a lateral view, but also when looked from above or below. Long face when seen from the side (great distance between nose and ear in the profile view).



If we observe this profile and compare it to the profiles seen above, we can see that the facial angle is closed and more acute, and the vertical straight line has turned into an "aerodynamic" wedge. In some ways, this race inherited the subnasal prognathism of former hominids, but the centre of maximum frontal projection (the angle's vertex) is raised from the teeth to the tip of the nose, becoming nasal prognathism. "Armenisation" manifests itself through a wedged profile, or in scattered traits such as receding forehead or chin, protruding

nose, and an inverted-triangle shape of the lower half of the face (from a frontal view). Thin, "sharp", bony faces, jaws with the shape of an inverted triangle, are Armenid heritage. It is frequent in China, where the most characteristic Armenid features (like the nose) are blurred by mongolisation (the Armenid and Mongolid races are somewhat opposite morphologically and tend to "cancel" each other out). This is consistent with the fact that the paternal O lineage, probably an Armenid haplogroup, is predominant in China.

- **Forehead:** Receding (sloping backwards).

- **Jaw & chin:** Thin, small. Has the shape of an inverted triangle when seen from a front view. Weak and receding chin.

- **Other features:** "Aerodynamic" face, not only at the vertical axis but also in the horizontal. Central facial parts projected forwards (with zenith at the nose), receding peripheral parts. Sharp, edged, dry, hard and bony facial features.

- **Paternal lineages (Y-DNA):** F, G, H, J, K, L, M, N, O, P, Q, S, T. There are particular doubts about the racial affiliation of the LT and MS branches, that could be different races, derived from the Armenid and not yet identified. Valg has also noted a lacuna in the J lineages, as Yemen, the zone where these haplogroups reach their highest frequency, is not a particularly armenised region, but there is an NR or pseudo-NR influence. If it were so, it could be a link between the NR and NB races.

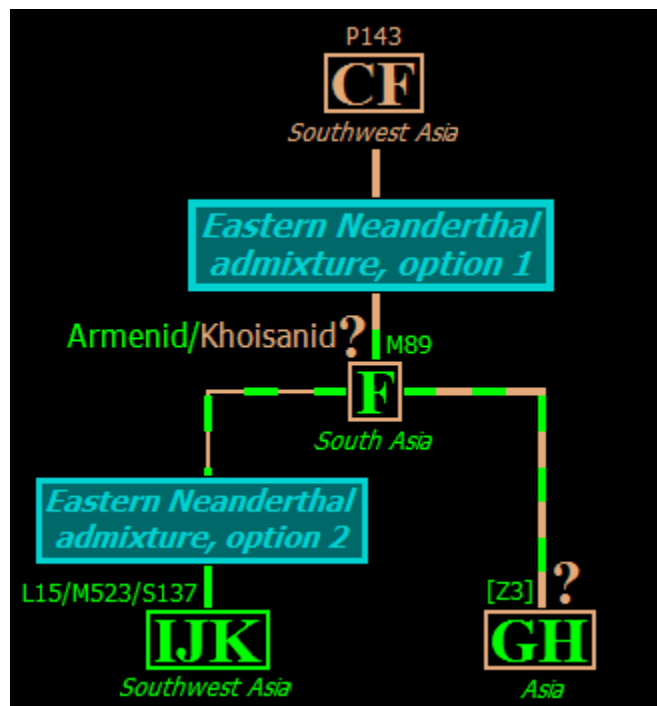

Armenid origins based on paternal lineages. Again, we do now know which was the first Armenid haplogroup. The first option is F, that could have formed after CF (Khoisanid) intermixed with the Eastern Neandertal race. This would imply that all haplogroups derived from F would be Armenid, except for White and Red Nordids, and maybe the LT and MS branches. The second option is that F was still Khoisanid and that the interbreeding took place only in one of its branches. Thus, GH and its stems would still be Khoisanid haplogroups, while IJK would have been the first Armenid lineage.

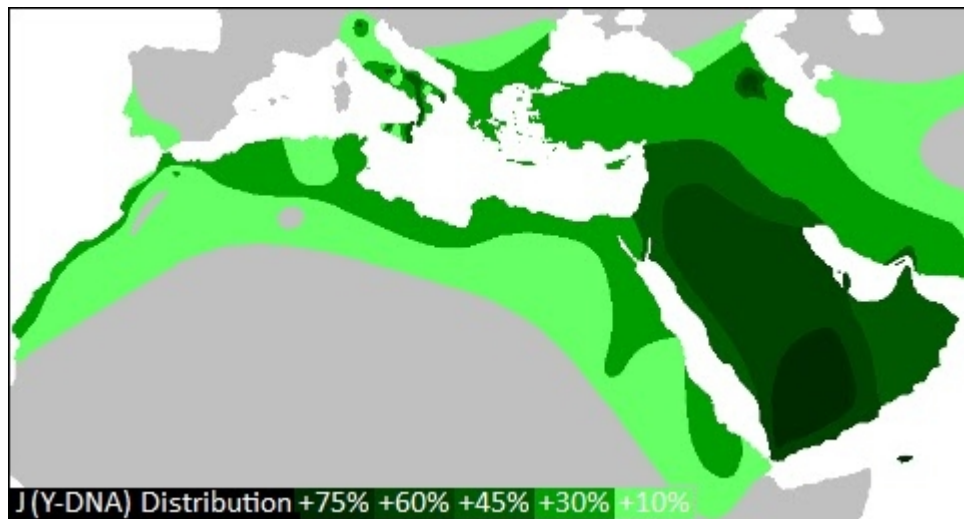

This interesting map combines the distribution of all J lineages, which seem to have their strongest core in the "Yemeni" type of the Southwest Arabian Peninsula. J haplogroups are often related with Semitic heritage.

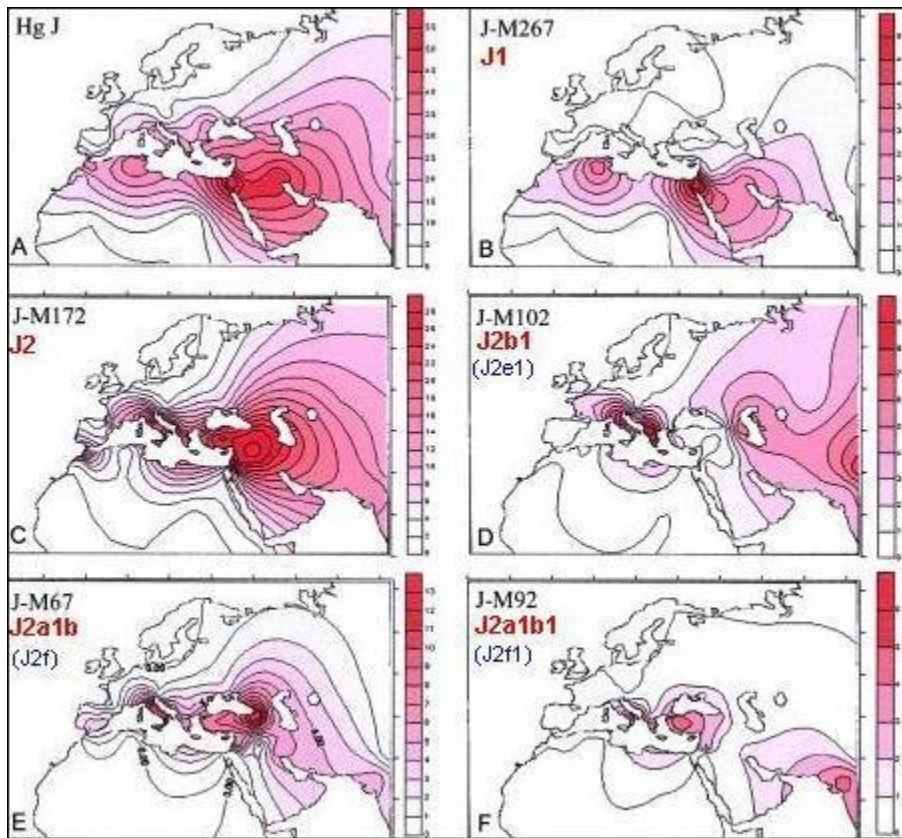

Each map corresponds to a different J sub-lineage. Let's pay attention to the second one in the first row (J1), which is the typical paternal haplogroup of Jewish Kohanim priestly families. Its highest concentrations seem to be found in the Sinai, Egypt and South Israel ("Judea").

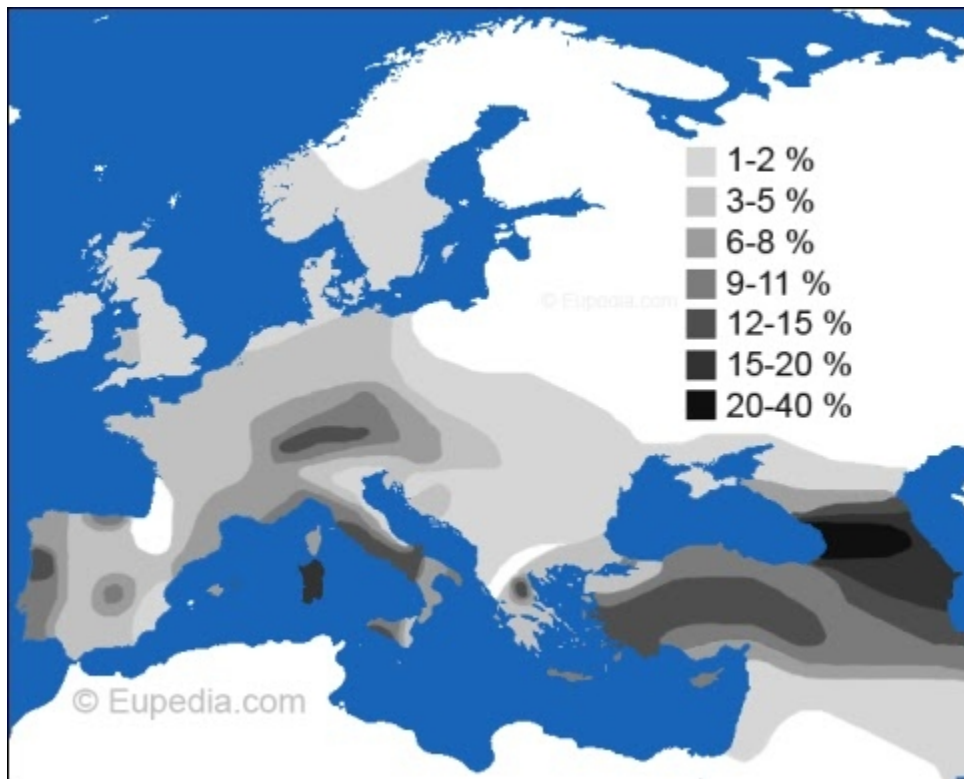

G2a (Stalin's paternal lineage, G2a1a) distribution. Although we consider it Armenid for the time being, it could also be Khoisanid or even Red Nordid. Source: Eupedia.com.

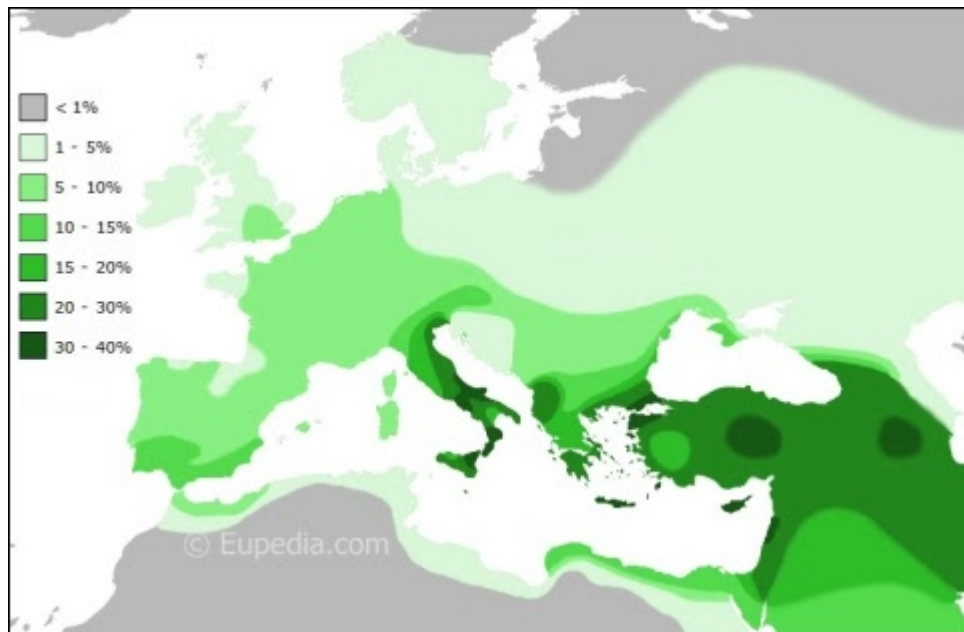

J2 frequencies in Europe and the Near East. Source: Eupedia.com.

• **Maternal lineages (mtDNA):** A, B, F, I, J, N, P, Q, R, S, T, X, Y. It will be noticed that, in Europe, Armenid maternal lineages are more common than paternal ones.

• **Spirituality:** Related with the Earth and home. Cult to a long and prosperous life. Tendency to asceticism. Fanaticism, intransigence, human sacrifices.

• **Psychology, idiosyncrasy and racial character:** Liking for personal benefit, love for short term usefulness, astuteness and shrewdness. Calculating, predisposition to materialistic intelligence, commerce, diplomacy and search for personal advantages. Easiness to glimpse and prejudge people, ability to grasp persons' weaknesses. In civilised multiracial societies, slave trade, white slave trade, smuggling, piracy, legal and illicit business, "organized crime".

• **Distribution:** This race, mixed as it is, was immensely prolific and successful, being extended all over Europe, North Africa and from the Near East to India and beyond. The purest cores correspond to the greater-Armenian sphere, the Caucasus, Syria, the Balkans and Italy.

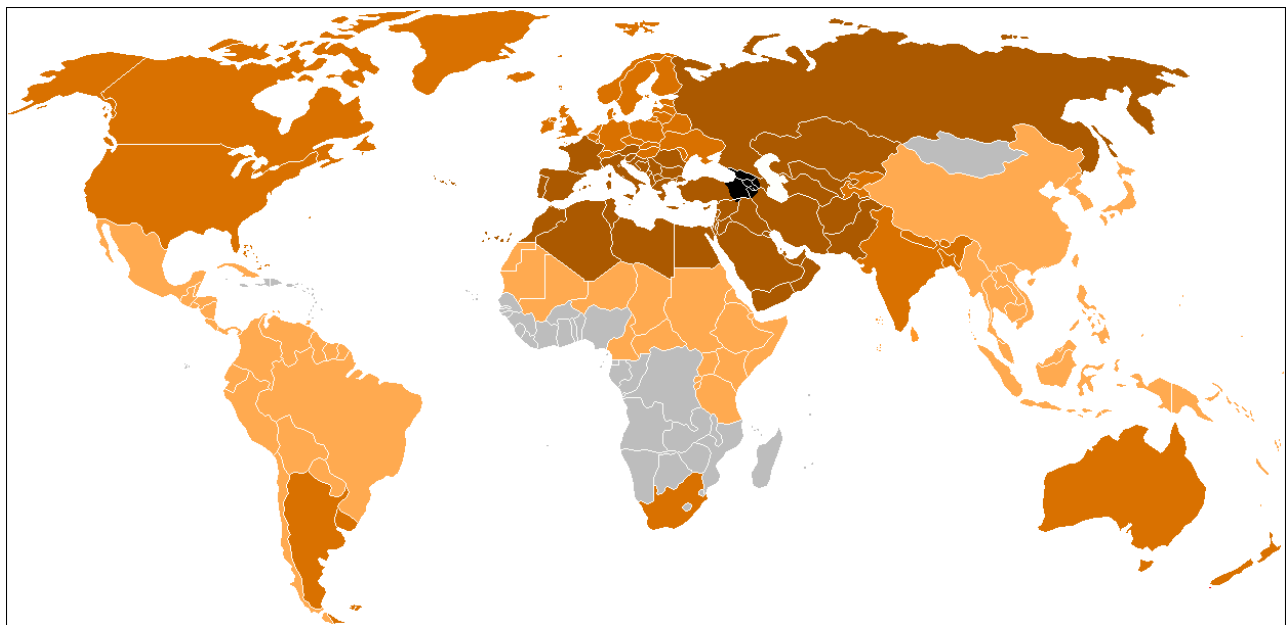

Armenid genetics' distribution by country. Darker the countries with higher quantity and/or purity of Armenid heritage. One thing that might surprise about this map is the similar level of armenisation in North Africa and Southern Europe. It must be clarified that in North Africa, Armenid blood is heavily mixed with Congid traits, while in Europe, it's mainly mixed with Nordid ones. The Armenid influence in China may also be noted. Although in this country (depending on regions and ethnic groups) Armenid features might not be so apparent (mongolisation "blurs" Armenid features a lot since they are very "opposite" races) the fact remains that the paternal O haplogroup (an Armenid lineage) is predominant. So we have a region where the paternal direct lines are Armenid, but the indirect or autosomal contributions are full of Mongolid, Red Nordid and other influences.

• **Brief History:** Armenids originated circa 60,000 years ago from the proto-Khoisanid race (a primitive human model from Africa, of which few remain today). This proto-Khoisanid race, from Eastern Africa, with an extremely delicate constitution and a straight facial profile, entered the Arabian Peninsula and the Near East, where it received genetic contributions from the Eastern Neandertal race. Afterwards, the hybridisation stabilized, natural selection acted over it, there were mutations and changes in the adaptation functions and finally the Armenid racial type was minted.



The development and expansion territory of the Armenid race. The main Eastern Neandertal sites are marked as an orientation. The most important is Israel, which groups many different sites, displayed in another map below. According to paternal lineages, CF (proto-Khoisanid) derived on one side to C (giving rise to C3 and the Mongolid race) and on the other side to F, giving rise to the Armenid race and all its lineages, including the Nordid races, which almost certainly descend from Armenids. Thus, the Armenids probably had their origin in some place of the Near East, probably in connection to the Neandertal sites in the Eastern Mediterranean.

The Armenid race had an overwhelming success, which is manifested in the dispersion of its lineages in uncountable branches, and in the diffusion of its physical-anthropological traits in all continents. Its diversification was such that we doubt if it could have produced other non identified races (especially in the LT and MS branches).

Armenids correspond to the great social mass of the first civilisations in the Near East. They would also correspond to the so-called "Neolithic Europeans" (the popular "gracile and dolichocephalic Mediterraneans"), related with Near Eastern cultures that started to enter Europe circa 7-8,000 years ago (e. g. [Cardial Ware](#)).

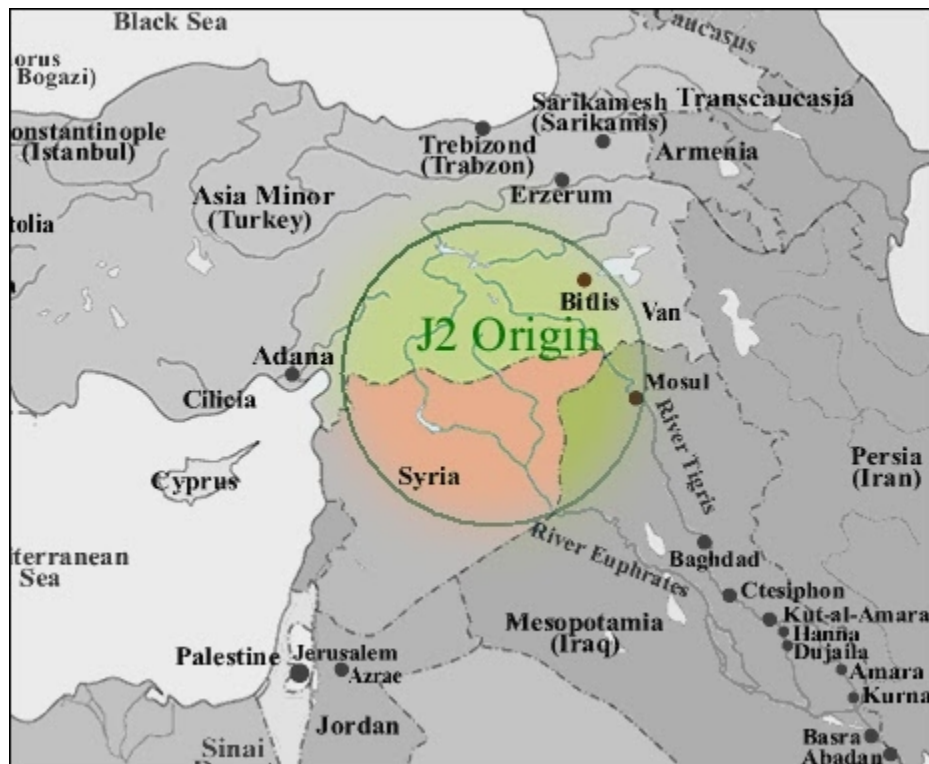

J2 haplogroup (considered "Arabid" might be a good reference to located the *Urheimat* from which Armenids entered Europe. It could also be indicative to locate the first Semites (after J1, J2 is the most typical haplogroup of Kohanim or Cohen priestly Jewish families). Minoans and Etruscans also had high frequencies of this haplogroup.

The aforementioned Neolithic cultures spread throughout the whole Mediterranean, intermixing with Red Nordids, and penetrated the Danubian corridor towards Central Europe (present-day Hungary and Austria, where they came into contact with White Nordids, this also happened in the Balkans). It is believed that Etruscans, Minoans (bull worship reminiscent of Eastern populations), Phoenicians and Carthaginians predominantly carried J haplogroups, though apparently their ruling castes were further mixed with R1a and R1b and there would have been certain amount of E1b1b (Congid) too. In Egypt, the paternal T lineage prevailed, though there must have also existed Red and White Nordid contributions judging by some mummies' appearance and some genetic analyses (e. g., Tutankhamun was R1b1b2). The Indus civilisation was probably predominantly Armenid (L) with some Red Nordid (R2) contributions.

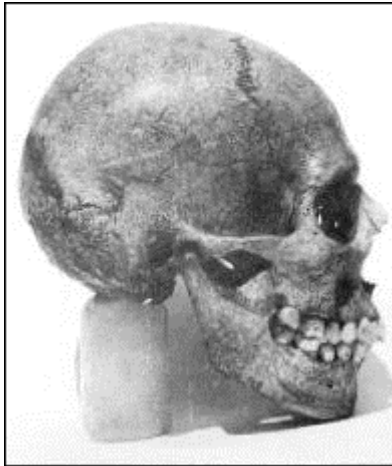

Early Minoan cranium, Greece, circa 2500 BC. Although it's risky to draw racial contributions and this is not a pure specimen, this cranium presents a high cranial vault, receding forehead, a high and protruding nasal bridge and Armenid curvoccipitaly.

In North Africa, Armenids produced the "Moorish" type by interbreeding with Red Nordids and especially Congids, while the further we move eastward, the less Congid influence is found and the more other races (Mongolid, Australid) are present. Nowadays there is Armenid blood in almost all Eurasia, North, East and even Central Africa, and also in pre-Columbian America (noses that are not Mongolid at all can be observed in many Native Americans or in certain Aztec reliefs).

• **Present context:** Being an older race than any of the Nordid ones, it is extremely difficult to find pure Armenids, as they have had more time to crossbreed, and might have been less racist by nature. The Armenid heritage is what gives typical "Semites" their large noses and receding foreheads —but what we understand as "Semitic" is usually an individual with more Red Nordid than Armenid contributions.

ABOUT NEANDERTAL MAN AND THE ARMENID RACE

Neanderthal is a human race that arose about 230,000 years ago, "became extinct" 28,000 years ago, and spread mainly between Europe and the Middle East. Mitochondrial DNA (maternal line) analyses show their lineages to be far more distant apart than modern humans (something normal for a race that scattered and lived for 200,000 years, most of the time living under hard natural selection and isolation of entire clans). Palaeoanthropologists have identified at

least [three Neandertal races](#) (one of which was [red-headed](#), though due to a different mutation than modern Red Nordids).

Although it was always clear that, because of chronological, geographical and logical matters, Neandertals had coexisted with Homo sapiens for millennia, the possibility of racial interbreeding (suggesting modern humans could have Neandertal blood) was not accepted until very recently. Mainstream science *decided* Neandertals belonged to another species and that, even if they met anatomically modern humans (indeed, some scientists stated that Neandertals and Sapiens never actually saw each other, despite inhabiting a common territory for thousands of years!), their descendants would have been sterile, as they allegedly belonged to different species, so that Neandertals "became extinct" —because of climatic change or due to competition with modern humans. From time to time, [some voices](#) appeared suggesting that there was [enough evidence](#) to seriously consider the possibility of modern humans having Neandertal contributions in their genome. For instance, in Lagar Velho, Lapedo valley (Portugal), remains of a hybrid Neandertal/Sapiens child were found. This child was dated back to 24,500 years —at least three millenia after the alleged Neandertal "extinction".

Valg noticed long ago that, on the basis of cranial morphology, there was a particularly clear Neandertal contribution in many Middle Eastern individuals, that he associated with the Armenid race. He also considered that another different Neandertal race could have had something to do in the conformation of the Red Nordid race. Because of the fast advances in the field of Genetics, it was a matter of time that further evidence would substantiate these voices.

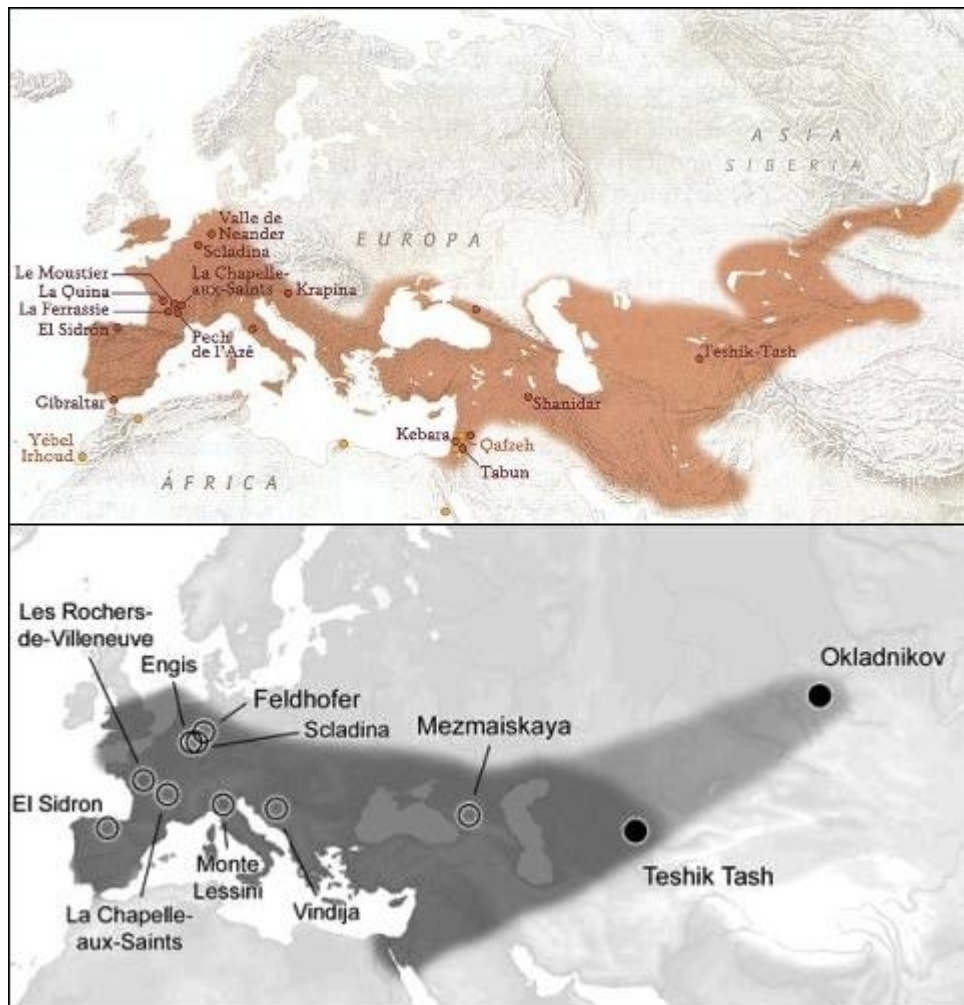

Area inhabited by Neandertals. Due to the great isolation of reproductive communities (forced by geography and the glacial rigours), Neandertals diversified and gave rise to, at least, three well-differentiated races. On account of its connection with Armenids, we'll pay attention to the Eastern Neandertal race, with a more gracile constitution than the massive European type.

Thanks to mtDNA analysis, it is confirmed that Neandertals and Sapiens did interbreed, and that this took place in the [Eastern Mediterranean](#), probably when Sapiens coming out of Africa stumbled upon Neandertal populations such as Skhul, Kebara, Hayonim, Tabun, Qafzeh, Amud, Zuttiyeh (Israel), Dederiyeh (Syria), Shanidar (Iraq), Kermanshah (Iran) or Karain (Turkey). There must also have been plenty of Neandertal sites in what now is undersea, off the coast of Israel, Turkey, etc.

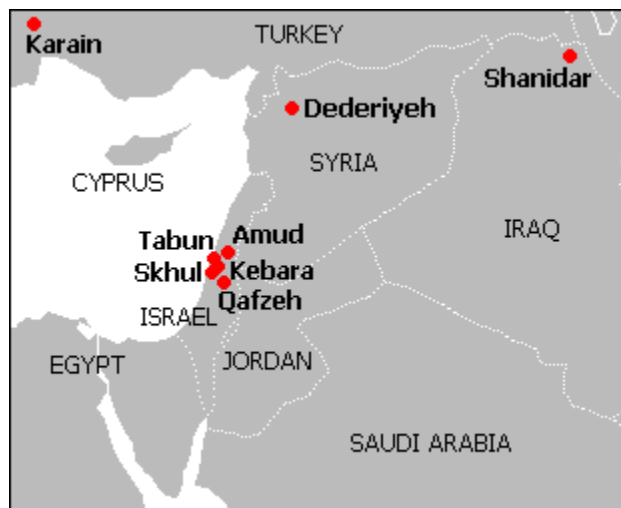

Most significant Neandertal sites in the Near East. [It is considered](#) that the Israeli core was the epicentre of interbreeding between native Neandertals and "modern men" coming out of Africa.

Neandertals, with their high cranial capacity, strength, corpulence and adaptation to such a tough and resource-scarce environment as the glaciation, were evolutionary ahead of the "archaic Homo sapiens" they encountered —which were probably the ancestors of the modern Khoisanid race (an African variety, perhaps the most ancient human race that remains today). As a result of this interbreeding, nowadays, Eurasian populations have between 1 and 4% of genetic Neandertal contributions. With no hesitation, we affirm those contributions to be even more important in highly Armenid individuals.

On the basis of Physical Anthropology applied to the study of ethnic groups carrying certain haplogroups, the first Armenid lineage was F or IJK (less probably, K). Therefore, Neandertal interbreeding in the Near East must have taken place within the time period stretching from before the appearance of the F haplogroup to before the appearance of the K haplogroup, which gives us an interval of 70,000-45,000 years bp. In some places, the interbreeding has been given an antiquity of 65,000 years, in others 65,000 years and in others it has been dated back to 80,000 years. Interbreeding in Asia is reported to be 45,000 years old. We will see this more clearly in the diagram dedicated to paternal lineages **[6]**.

More important than Neandertal's role in the formation of the Armenid race, are the implications entailed by admitting that *Homo sapiens* interbred with *Homo neanderthalensis*. On the one hand, terms such as "species" and "race" should be reconsidered. If both had fertile descendants, then they were not different species, yet they were different enough to be considered races. The same can

apply to Homo erectus and the various pseudo-Erectus (Ergaster, Georgicus, Pekinensis, maybe Antecessor and Heidelbergensis): they may be several races of a same species, as we have no proof to assert that Erectus (or even Homo habilis) was a different species from our own. On the other hand, if it has been finally accepted that there are other hominids' contributions in the current Eurasian gene pool, we could direct our attention to Africa and to human races like the Congid, Pygmid and Australid. All humans probably descend from a pseudo-Khoisanid race with a straight profile. We have accepted that the angulation of the facial axis (for example, a receding forehead) was acquired by interbreeding with another hominid, in this case, the Neandertal. We should ask ourselves about the subnasal prognathism of "Negroid" races, and come to the conclusion that this trait was also acquired by [interbreeding with other hominids](#). This fascinating topic will be discussed in a future article dedicated to the rest of human races.

REFLECTIONS ON THE ARMENID RACE

It's easy for the Armenid race to fall into stereotypes and misinterpretations, so it is important that we provide some information to put the Armenids in the right place.

1. The "Semitic" label must be avoided

It is tempting to link the Armenid race with Jews, Arabs, Judaism, Christianity, Islam and gypsies, thus identifying them with historical trends that have traditionally acted against the Palaeolithic genetic legacy accumulated in the European continent. However, this is oversimplification. These historical forces did indeed renew the Armenid flow towards Europe, and they originated in region with a predominance of Armenid paternal lineages, yet they were not born in pure Armenid cores, but rather in areas where civilisation had been deeply-rooted for a long time (ergo, regions of ethnic chaos), where Red Nordid and Congid influence was very important, and where intolerant creeds were necessary to unite human masses who otherwise lacked ethnic cohesion.

2. The birth of agriculture

Civilisation is inevitably bonded to cereal agriculture and the sedentism it produced. The use of wild cereal grains is proven in places such as Ohalo II, an Israeli site dated in 23,000 years. Moreover, the expansion of rice cultivation in Eastern Asia is related with the paternal O3 haplogroup, an Armenid lineage. Considering that, as said before, the lowest celiac disease, gluten intolerance and lactase persistence frequencies in Europe are to be found in Greece and Southern Italy, I'm inclined to consider cereal cultivation as Armenid in origin. Another fact that supports this idea is that nowadays, highly Armenid individuals maintain a slender and lean physical constitution despite having a strongly cereal-based diet; this implies they assimilate starches better than, for instance, Red Nordids.

Another fact that could confirm this relation is that the agrarian settlements of the first Neolithic are characterized by gracile and dolicocephalic skeletons, something clearly contrasted by Archaeology. Valg does not share this opinion and relates Red Nordids with agriculture as well as stockbreeding.

Civilisation probably can't be attributed to any pure race, as it is a product of alienated and genetically mixed societies, but it is probable that the inflection point in civilisation's development was the moment certain Red Nordid clans came into contact with Mesolithic Armenid communities of the Near East (e. g., the Geometric Kebaran culture).

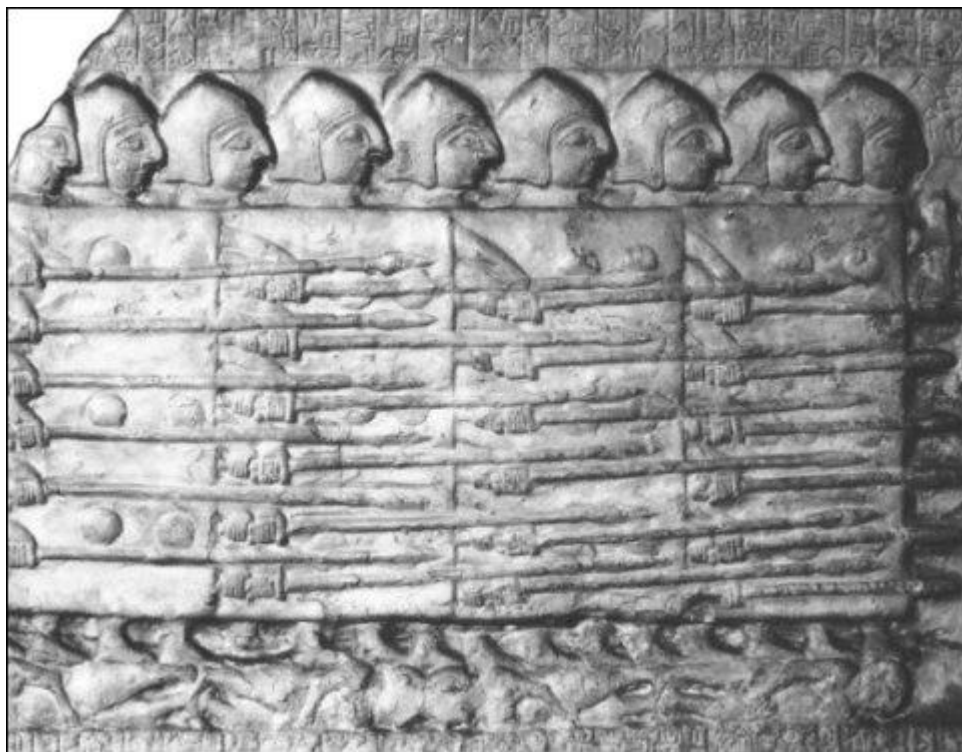

Fragment of the Stele of Vultures, a well-known Sumerian relief (present-day Southern Iraq) sculpted circa 2500 BC to commemorate the victory of the city-state of Lagash over the city-state of Umma, and that represents a phalanx of soldiers advancing over the corpses of their enemies. Although Sumeria has other artistic pieces that depict individuals (specifically of the social elite: priests, ladies, etc.) of a clear Red Nordid base, it can be inferred —judging by the noses and the general profile of this group of soldiers, very homogeneous racially— that the great popular mass of their civilisation had an Armenid racial core. It can also be deduced that the origin of closed combat-formations shouldn't be looked for in the European past, but in the ancient Near East.

3- The Armenid race has played a major role and has been present in all civilisations

It can be said without exaggeration that the Armenid race has been present in absolutely all human civilisations. The great mass of ancient Egyptian population belonged to the T lineage, and even the Pharaohs, among whom Red Nordid contributions were important (abundance of blonds and redheads, Tutankhamun R1b paternal lineage), were strongly armenised. As of Rome, there was a strong armenisation (Cato the Younger, Julius Caesar), so much, that individuals of a very pure Armenid stock are expectable to have lived in Italy during the rise of Rome.

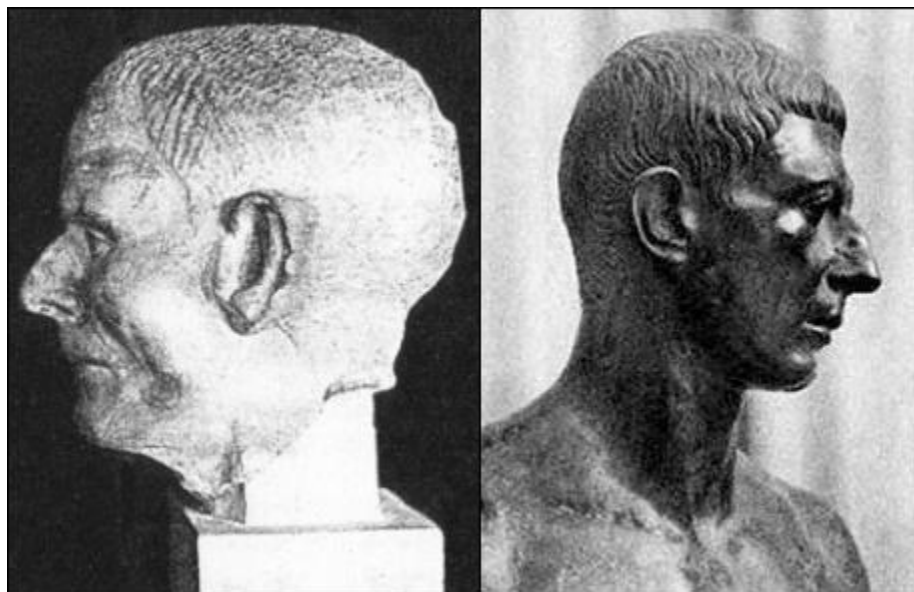

The dominant racial contribution among the Roman ruling caste was clearly Red Nordid, followed by some White Nordid (more apparent in individuals such as [Vipsanius Agrippa](#) or [Caesar Augustus](#)). The Roman populace must have had higher Armenid contributions. However, as evidence that the Armenid blood was strongly represented among

the influential class, we have the bust of a Patrician (left) and of Cato the Younger (right) — though it must be remembered that Cato had plebeian ancestors. This entails that during this period, there must have been very pure Armenids in certain regions of Italy, and that within the legions (whose combat tactics weren't different from the Sumerians we have seen above), much Armenid blood must have been present.

EVOLUTION OF LINEAGES AND THE FUTURE OF THE HUMAN SPECIES IN THE GLOBALISATION ERA

We now face a great current which is trying to create a genetic levelling, in order to turn mankind into a flock suitable to subjugation by a plutocratic elite, and to increase some points the intellectual quotient of border-line races by mixing them with intelligent races. Now, in the time of fights over resources and the poisoning of the Earth and of the genetic code of all human varieties, it will be necessary to establish a new selection and a new evolutionary leap in order to render obsolete, not only all previous human races, but all Homo sapiens as a species. Everything that is now brewing in terms of changes and agitations, will find a meaning in the birth of a new variety, fathered by the European kind. The tree of the human species is ready for the ripe fruits to fall from its best branches, and whose seeds will give rise to a new tree.

[CLICK HERE](#). This diagram displays and summarises the new racial classification from the phylogenetic perspective —in this case, through the evolution of paternal lineages. It's free distribution is encouraged. Content modification is not allowed. There are some branches we do not know what race to assign them to; Valg expects to elucidate most of these doubts by the physical-anthropological study of certain ethnicities, especially from the Indo-Pacific region. Many relevant aspects on the first stages of evolution will be discussed in the second part of the present article, dedicated to the rest of human races. Images of pure Khoisanid, Pygmid, Congid and Mongolid specimens are yet to be found. Some branches are yet to be defined, for instance, C2 could correspond to an Australid race. This diagram will be further updated along with the advances we make. The date of the latest update is located in the lower left corner.

mtDNA racial origin

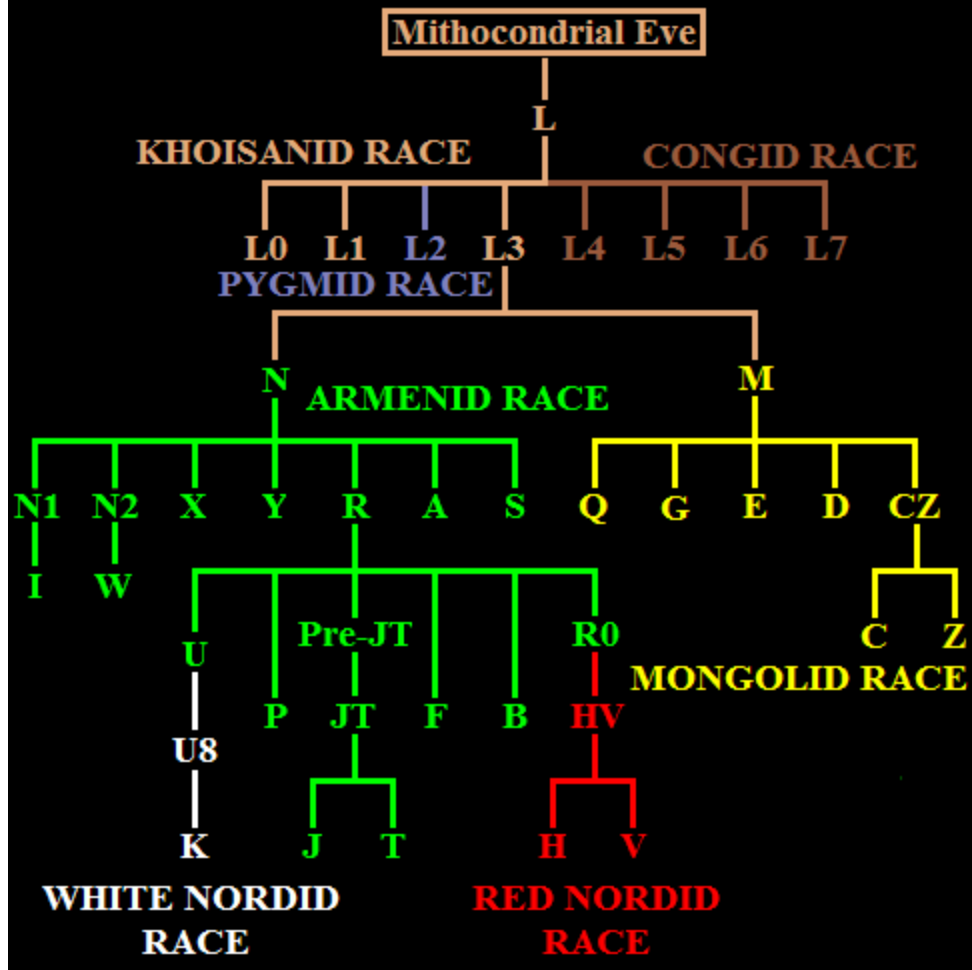

Suggested evolution of maternal lineages, from a racial point of view. Light brown: Khoisanid lineages. Dark brown: Congid. Bluish: Pygmid. Yellow: Mongolid. Green: Armenid. Red: Red Nordid. White: White Nordid. To determine maternal lineages by race is much more complicated than doing so with the paternal ones. For this reason, this diagram is merely for orientation. For instance, the adscription of the Pygmid race raises many doubts. It must be made clear that the reality of maternal lineages is distant from being as simple as this diagram, much more provisional than the previous one.

GENERAL REFLECTIONS

This topic could be further discussed, but for the moment I will introduce some brushstrokes:

1. The original, pure racial types present a *harmonic coherence* in all their traits

Each race, when pure, has an inner harmony manifested by the congruent personality of its external features. Red Nordids are incandescent, red, corpulent and orange-haired, whereas White Nordids are golden, athletic and blond, Armenids brownish, gracile and with black hair, and so on. Everything is in its place, there aren't any dissonant traits that seem "out of tune" in the general arrangement, or that appear to contradict the rest, or to struggle against each other. This harmony is also interior. Only racial interbreeding disturbed this primary equilibrium. The first effect of racial mixing is to destroy the integral consistence of racial features, and that has its echo in the psychological and spiritual fields. It's obvious that mixes are contemplated by Nature: the Armenid race comes from one, but this mix subsequently evolved, muted and underwent natural selection by the environment, in natural conditions and obeying the tough laws of Darwinism, until it stabilized in a new racial type many millennia later. Disordered mixtures, typical of globalist civilisation, have nothing to do with this natural *laissez-faire* envisaged by the natural order.

2. Race mixing is an attack on human biodiversity and an aggression against dozens of millennia of evolution

Each race is the result of long and ruthless processes of refinement, tuning, honing, isolation, adaptation and natural selection. In the times when life was pure and Nature followed her path unaltered, each race was walking its own path, straight ahead to become a different species. This was before the rise of materialistic civilisation, which perverted the natural order, consummating its hatred towards Nature and mankind, and materializing its resentment towards biological nobility by preaching equality and promoting chaotic crossbreeding. To mix with another variety —the further in the evolutionary scale, the worst— is an abomination and an affront against all this work of perfection and natural/sexual/artificial selection of dozens of thousands of years.

3. Primitive races feel sexually attracted to modern ones —a threat to evolution

Primitive races have an instilled instinct to procreate with the modern ones. This has been ever translated into millions of rapes and kidnaps of European

women [7], including the unprecedented rape epidemics suffered nowadays due to third-world immigration in Europe and Oceania, and to forced "integration" in North America and South Africa. This responds to the instinctive desire to improve the genetic code without evolution, that is, without the lengthy effort of undergoing a severe natural selection. It also responds to an indiscriminate sexuality, developed to compensate with numerical *quantity* a lesser individual *quality* (theory of r/K reproductive strategy). Nevertheless, it is no excuse, as the genetic code is not improved by this kind of attacks on Biology. The interbreeding would only "benefit" the most primitive race involved, whereas the modern becomes debased: being the primitive the ancestors of the modern, the Nordids can only expect a backward leap of dozens of millennia in the evolution of their genetic code, and traumatizing their genome for ever if they crossbreed with other reproductive communities. If we additionally consider how innocent and carefree modern races are (self-confidence in one's capability tends to relax defences against much shrewder races), we are faced with a serious threat of human involution.

Summing up, the promiscuity of primitive races (also of the most dysgenic and defective individuals of modern races) is a threat towards the genetic integrity of modern races, and thus to the evolution of all mankind.

4. Oestrogenisation and feminisation of the modern races —another threat to evolution

It is undeniable that since the Neolithic brought along the grain-based diet —a nutrition that tends to [blur sexual dimorphism](#) and therefore to wipe out differences between sexes— civilisation has pulled the hunting man away from Nature and wildlife, from natural instincts and from original savagery, and this has resulted in a castration of the species. Obviously, this process has been stronger in the civilised regions, which in the long term, matched those that housed the most gifted races. On the other hand, the less-civilised areas have remained closer to the natural state, better preserving their instincts and "authenticity". This threat is the flip-side of the previous point. And on the one hand, these societies are capable of competing, not economically or militarily, but demographically and socially, with the most civilised societies, which they despise for their softness. Finally, women tend to feel attracted to well-androgenized and well-sexed men, with traces of hunting and warlike behaviour. The feminisation of the Western Civilisation and of the white man —a process sponsored by multinational corporations— has the effect of throwing the women of the modern

racés into the hands of primitive races. The new masculinity of the working white man, of the *gentle-man*, obsequious and servile, is a failure from the reproductive-evolutionary perspective, and the time is ripe to see a rebirth of the instincts that civilisation stole from the European hunter. The difference between him and the modern bourgeois European is not less than the difference between bulls and oxen, or between wolves and lapdogs.

When one side of the scale falls, the other rises: the taming of modern races runs parallel to the galvanisation and bolding of the primitive races, who under the protection offered by our civilisation's naïve generosity, reproduce in ghettos and *non-droit* zones that have turned into real fermentation tanks of violence, resentment and instincts. It is not required to be a prophet in order to foresee that nothing good for Europe will come out of this situation.

5. The isolation and constitution of closed reproductive communities played a key role in evolution

For a population to mutate and thereby to evolve (since mutation and natural selection are the leading ingredients of evolution), it is essential not to mix with genetically different populations. For this reason, as all farmers and stockbreeders very well know, the formation of isolated populations (i. e., unique reproductive communities) is a vital step for evolution, because, within these communities, mutations occur at a higher rate, and the selection of the desired and advantageous traits is minted more effectively. Under the rigours of natural selection, this is the first phase for the constitution of a different race. Moreover, the formation of a new race is only the prelude of the formation of a new species.

Some day, when Genetics and the study of the human races flourish, or simply under the pressure of new general circumstances, new reproductive communities will have to be formed to save human evolution. For that, it's vital to learn from those who, in the past, tried to do the same.

6. Diversification and evolution go side by side

I have never seen a tree whose branches, once a certain height is achieved, converge to form a common, "mixed" trunk. Normal is that, as any tree grows, its

branches split from the common trunk and diversify more and more. That is what life and evolution are all about.

Branch convergence only takes place when, instead of upwards, we take the downwards direction and operate a backwards step, pulling back the most advanced branches and the nearest to the Sun: now the tree has stopped growing and has begun declining.

7. Marriage is a biological mission —evolutionary importance of mate selection

Nowadays, when the great majority of European population can be considered mixed, the least we can do while genetic engineering, "designer babies" and the like advances don't prevail, is to choose well the person we are going to have offspring with. Being "white" is not enough; he/she must be genetically compatible, which can be ascertained by a physical-anthropological study and a genetic analysis. These options amply surpass the possibilities of the arduous genealogic research of older times (like those conducted by the Spanish Inquisition or the Nazi SS). The ancient Caste System must be followed: similar joins similar.

In order to fulfill this, the sad, monogamous, bourgeois modern marriage, based on material profit, prostitution, parasitism, indolence and domestication, must disappear in favour of the idea that marriage is, first and foremost, a mission on behalf of the species and the improvement of our descendants' genome. The aim of marriage is to join two compatible beings to father children with a good genetic quality, so that they can take evolution another step forward. While this premise (the individual is nothing, the species is everything) is not fulfilled, marriage makes no sense and is not admitted as valid by the natural law.

8. It is necessary to regenerate the genetic heritage of the West to avoid the biological collapse of mankind

Embryo selection, eugenics and genetic engineering could be fabulous tools to regenerate the "white race", but for this to happen, first we must knock over the anti-evolution, anti-natural selection and egalitarian obscurantism of the mass media, manipulated by international finance —which is not concerned with evolution, but with corrupting anything noble and pure and burying it in the

rotten matter of an inferior world order. The current system takes delight in dysgenics and is not interested in improving the species, but rather in earning money without working (that is, profiting from somebody else's work: usury) and obtaining pleasure in a quick, cheap and immediate manner, which has nothing to do with improving the genetic code or surpassing the limits of the human being. It's worth remembering that to help less intelligent races only helps them, whereas to help intelligent races helps everyone, as problem-solvers are most likely to come up with solutions.

Nowadays, nothing selects us; human reproduction in modern society doesn't differ much from a mass in fermentation. Perhaps it can be said that we are not selecting a human type convenient for the species, but one convenient for the economic system: a tame, obedient, consumerist and submissive workforce, endowed with the qualities expected from slaves, cattle and domestic animals. Usurer, globalist and neoliberal capitalism wants a rootless, mixed, unidentified, herd-like, equalized and highly predictable flock, whose behaviour can be manipulated easily. With this goal in mind, the modern financial-commercial system can feel tempted in the future to use genetic engineering to manipulate the natural parameters of human behaviour and the racial composition of mankind. Nobody needs to be a genius to see that all this process is extremely dangerous, that it attacks the foundations of evolution and that the peoples of the world must revolt against the parasitical, financial, mediatic and political mafias that are keeping us in the dark.

9. The creation of man is not complete —races are the first step of the creation of new species

The fact that races can still interbreed and produce fertile offspring implies that the creation of races (which is only the first step of the development of new species) is not yet finished, and thus the creation of the human being is not yet complete. Man himself is nothing more than a provisional link to the creation of something that will surpass him. Human races were on their way to speciation, until the Neolithic opened the era of migrations, which meant a decline of the European genetic code and probably a compatibilisation of it with other races.

In turmoils yet to come, new leaders, enlightened by a biological mission, must stand out, draw science towards them, and separate the sheep from the goats, taking up again the upwards evolution of mankind from where it was left, carrying out a massive mutation in the West, and promoting the rise of a new species,

better endowed. This would complete the cycle of human creation, rendering the ancient Homo sapiens into a human "version" as obsolete as currently Homo habilis is. As spontaneous providence does not work anymore to favour evolution in an artificial world devoid of natural selection and submitted to the totalitarian principles of media and financial mafias, the so called conscious evolution must be established. This is a directed process for genetic improvement, conducted under the umbrella of Eugenics and genetic engineering.

10. Civilisation must not exist to promote the advance of matter, but the advance of man. Crucial importance of the development of Genetics and health knowledge: the development of a society is not measured by its development of inanimate matter, but by its development of alive matter

Civilisation is the result of evolved races, living under mild conditions thanks to the end of glaciation and the availability of the workforce of other races. We must be grateful to Nature and not take advantage of an interglacial period to attack her premises or question her paths. We should, therefore, bear in mind that civilisation must not exist to promote the development of culture, technology, luxury or comfort, but to promote the development of man himself: the evolution of the genetic code. For civilisation depends on genes, not the other way round, so it's ridiculous that civilisation turns against the genetic heritage that created it, like a snake that bites its tail.

From this perspective, furthermore, culture, science and technology are things that cannot be maintained indefinitely because they depend on the genetic capability of a minority within mankind, a minority that is not unlimited, has been wasted with no pause and has undergone a great degeneration after thousands of years without been cared for or renewed. Therefore, technology must be at the service of the advancement of mankind, not the other way round. With this in mind, Genetics is with no doubt the scientific branch which, apart from being growing and advancing faster than any other branch, offers the most fantastic possibilities for regenerating Western Civilisation. Like any double-edged weapon, Genetics also has a dark side: to allow the global financial elite to manipulate human nature itself in order to make it fit in the socio-economical model they desire.

11. To know other races is important

As a final reflection that will announce the next article on the same subject, it may be remembered that I mentioned other racial contributions in Europe. We will pay attention to the rest of the branches of the human tree in a future article, and we'll see to what point there are small quantities of Mongolid and Congid traits in the heritage of many Europeans considered perfectly white and even "Nordic". This article is incomplete without the future second part. Until we learn how to distinguish Khoisanid, Pygmid, Congid, Australid, etc., contributions, our formation in this sense will not be complete. All human lineages are interwoven in such a way that to understand one helps to understand the rest.

PRACTICE —LIVE SAMPLES

The fact that these racial types barely appear in a pure state and only in very restricted areas, can make racial facts difficult to understand for anyone lacking a properly trained vision. Indeed, most Europeans currently have traits from two or three —if not more— racial types, and only a good anthropological knowledge, together with a certain personal intuition, can help to read racial stratifications.

(Adriano Romualdi).

Analyzing features from a racial perspective is not a theoretical issue, but rather a practical one, in a visual way. It's all about gaining a racial sensitivity towards facial traits, developing a natural and instinctive suspicion, and deciphering a sort of universal code embedded in people's appearance, especially in the facial features. Someone who knows how to analyze facial traits can be almost as indicative as a good genetic analysis or even more, as up to this date, genetic analyses do not include detailed racial information.

The way to improve skills in the racial analysis of human physiognomy is to carefully examine countless human portraits and everyday faces, if possible, from persons with a strong "racial personality", and to make the most out of it. In order to identify human races, Valg studied literally hundreds of thousands of portraits from ethnic groups worldwide for years, paying attention to traits inherited from relatives, and to the most insignificant details; in such a way that before finding portraits of pure specimens, he already knew perfectly the sort of features he was looking for, as he had mentally isolated them.

Obviously, it is extremely hard to find pure specimens from the various races, but we need to recognize different races, even if they are diluted. It's necessary to learn how to identify an armenised forehead or nose, the strong chin of Red Nordids, the piercing stare of White Nordids, the dark skin and protruding mouth of Congids, the prominent cheekbones and slanted eyes of Mongolids and Khoisanids, etc.

In this section, "easy" examples will be provided, of individuals with, as aforementioned, a strong racial personality, easy to identify without much effort. They are not common racial types, not to find everyday on the streets, but the obviousness of their traits makes them suitable to start practising the new Physical Anthropology. In other future articles, I will use more common, and thus harder to decipher, examples, as well as "white" individuals with non-"Caucasian" influences. Whoever has an interesting portrait, can share it in the e-mail of this blog, and if it's representative enough, it might be added to this article or to a future one.

As will be immediately seen, we can't say "*this individual belongs to X race*", but rather "*this individual has a mixture of X, Y and Z in such proportions*". Also, it will be noticed that even those racial types traditionally deemed pure are, in fact, "contaminated" to a lesser or greater extent. Nowadays, blood is so mixed that only deep genetic job could clean each mixture. Nevertheless, things are not that easy as to give everything a miss and say "we are all mongrels", for there are highly different mixtures and proportions.

It is very striking to verify the extraordinary morphological diversity of the presented array of individuals (according to the official version, all of them are "Caucasian" and belong to the same "white race"), and this diversity will reach paroxysm when, in a future article, we handle the rest of human races.



1- This impressive individual, from Denmark, is a highly predominant RN. However, his eyes are not perfectly inserted in their sockets, his superciliary arches have become slightly deformed do to mixing and his skull, though broad at temple height, gets narrower towards the top: White Nordid and Mongolid influence, though very residual.



2- Interesting highly Armenid individual with WN admixture. Extremely residual congisation and redisation. He is most probably from the Balkans or from the Armenian and sub-Armenian regions of the Near East.



3- Successful Swedish athlete Carolina Klüft (178 cm - 5 ft. 10 in., 65 kg - 143 lbs.), is a highly pure White Nordid, though she has slight armenisation and redisation. Her eyes are mixed: closer pictures reveal them as being mottled with grey as well as navy-blue.

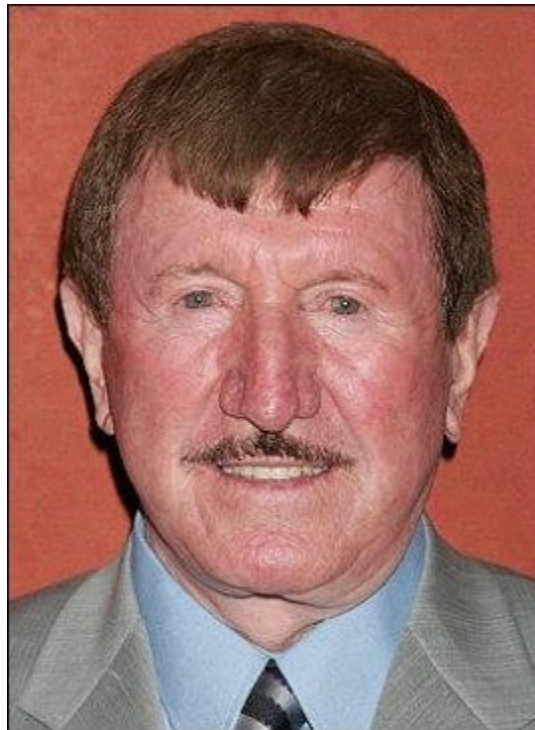

4- Basque singer Germán Lizarraga is an interesting admixture of highly predominant RN, some WN, Armenid and residual mongolisation.



5- Russian Alexander Godunov, a White Nordid with hardly any Armenid contribution. Very slight RN influence. Some extremely residual component of another race.

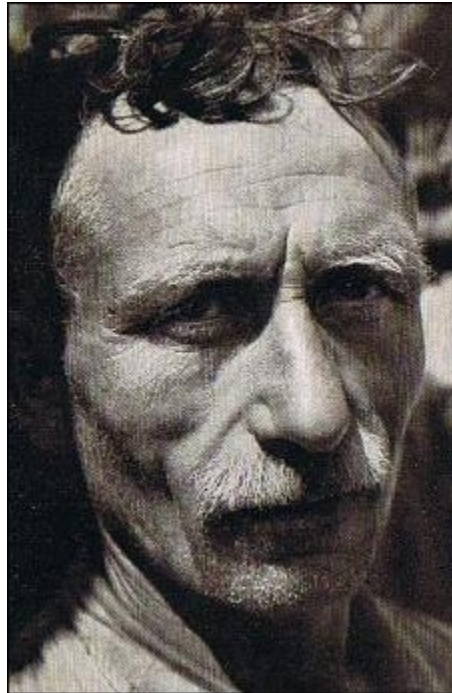

6- A rather balanced mixture of White and Red Nordid and Armenid, with a slight predominance of the WN part.



7- Prominent nose, receding forehead, receding chin, "aerodynamic" profile and ruddy skin: this man is mainly Armenid, with some Red Nordid and, to a lesser extent, White Nordid blood. As a marginal observation, it's curious how men with a strong Armenid influence tend to grow moustaches, as their moustache is especially bushy.



8- Peasant from Northern Friesland. Predominantly White Nordid with some Red Nordid contribution. Very slight armenisation.



9- Very armenised WN, or very whitised Armenid. Slight RN contributions.



10- This Englishman is RN, but not perfect (not completely red, skin tends to be paler and he has freckles). Observe the navy-blue colour of his eyes. A lateral view could tell us more. As extremely residual influences: mongolisation, armenisation and whitisation.

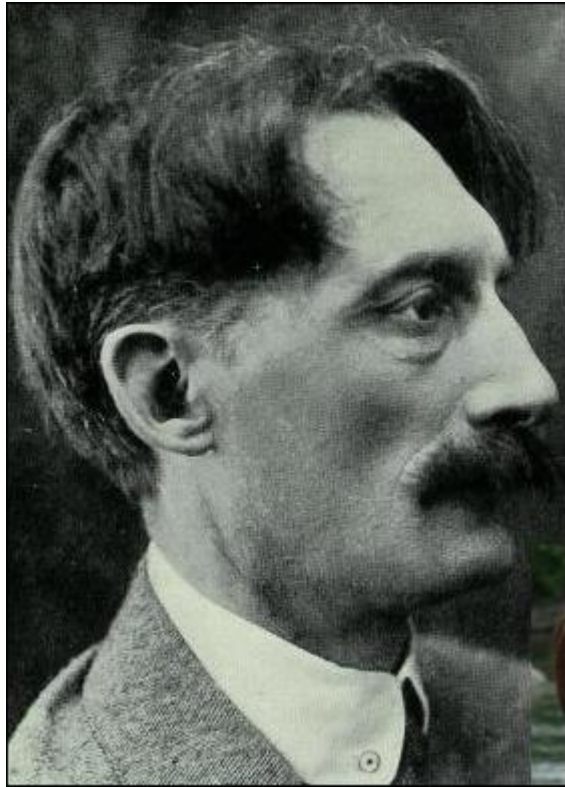

11- Highly Armenid. White and Red Nordid admixture. Probably very slight mongolisation.



12- This German is a White Nordid with some armenisation (nose), slight mongolisation (eyes) and slight redisation.



13- RN with WN, very slight armenisation and residual mongolisation. Eyes are of RN heritage (dark blue, small pupil). Notice that this kind of mixture is mainly found in Anglo-Saxon countries.



14- German football player Ramelow. Despite his pure hair colour and his clean features, he has some armenisation (forehead, chin and other features). Residual RN influence, extremely slight mongolisation. Otherwise, a very pure WN for nowadays.



15- Harder to identify mixture, as it is more balanced, but the picture is good: this Italian is a Red Nordid and Armenid mixture, with less Armenid and more RN than example No. 7. Small WN influence. His red side is manifested in the brown-reddish hair and beard, the rosy skin tending to have freckles, etc., whereas the Armenid part is clear in his forehead, nose, curvoccipitaly and in general, in his "aerodynamic" profile.

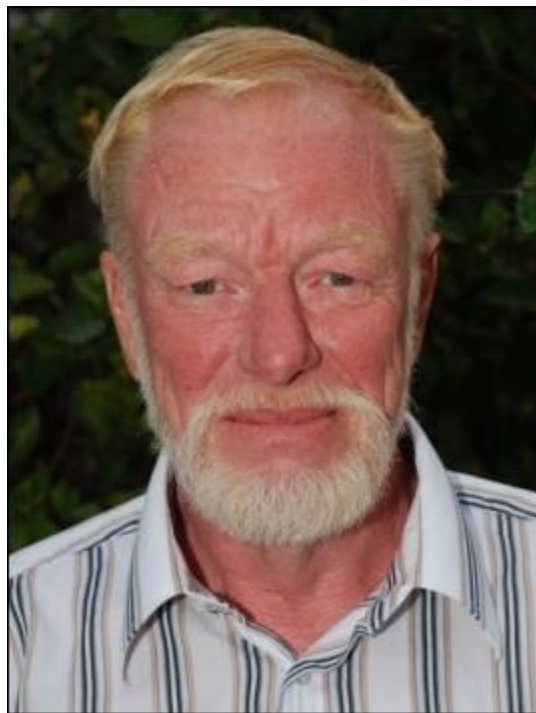

16- Higly RN. Slanted eyes: clear mongolisation. Very residual whitisation. No armenisation.



17- English athlete Iwan Thomas. Highly White Nordid. Slight redisation, visible in jaw, chin, shape of superciliary arches and freckles, upper chest and arms. Residual armenisation. Residual mongolisation.



18- This Swede is a highly predominant Red Nordid (jaw & chin, facial shape, mouth, dark-blue eyes, fleshy nose, rosy skin), yet with some White Nordid influence in the skin and hair colour, and in the eye's outline. Abundant type of mixture in Anglo-Saxon, German and, to a lesser extent, Slavic countries.



19- Highly Armenid Italian. RN influence which is manifested in freckles, jaw and a nose with a lower root than what would be normal in a pure Armenid.



20- English football player Danny Clay. Red Nordid, high WN influence. Residual mongolisation and armenisation.

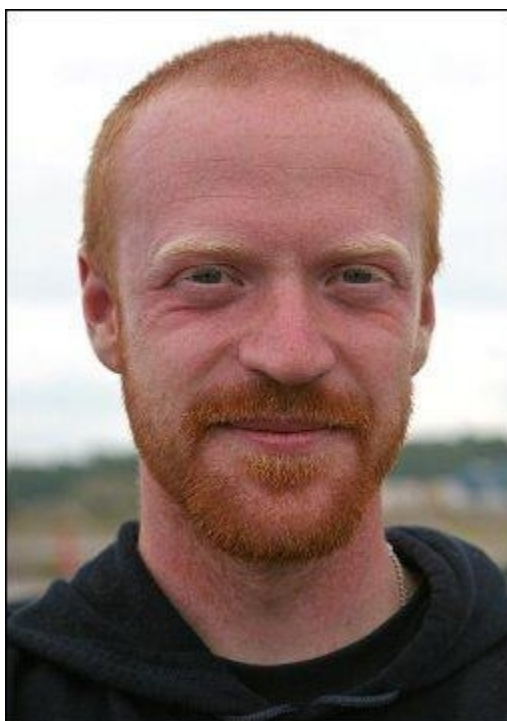

21- Highly Red Nordid, but significant Armenid influence, would be interesting to see a side view.



22- Swedish model Carolina Winberg. Very WN. Slight RN influences: note her profile, her forehead is so vertical it almost seems to form an inverted, "negative" angle. The jaw zone is redised. Freckles. Very light mongolisation. No armenisation at all.



23- Highly Red Nordid Norwegian. Armenid and mongolid influence.



24- White Nordid with an obvious armenisation (observe facial angle). Also residual mongolisation.



25- American comedian Darren Marlar. Highly predominant RN, with Armenid, WN and Mongolid contributions.



26- Welsh singer Rhydian Roberts. Highly WN, with a slight redisation and a residual mongolisation. As a matter of interest, and despite how slight his RN admixture is, Rhydian was ginger-haired as a child, and his chest hair is still reddish.



27- Swedish model, highly WN. Very slightly redised and with residual mongolisation and armenisation.



28- WN and RN with armenisation. Possibly, extremely residual congisation. Interesting to see how his hair tends to the WN colour and his beard to the Red Nordid.



29- Canadian actor Zack Ward. Predominantly RN, with WN, Mongolid and Armenid contributions.



30- Mongolized Red Nordid.



31- This Albanian football player is WN with RN, armenisation and mongolisation. Notice very wide philtrum and characteristic shape of the upper lip (WN influence).



32- RN and WN admixture, with a clear predominance of the RN element. Possible extremely residual armenisation.



33- Girl from the Kalash ethnic group (Northern Pakistan). Strongly White Nordid, slight Mongolid admixture. Residual armenisation. Her purity is astonishing, especially taking into account the region she is from.

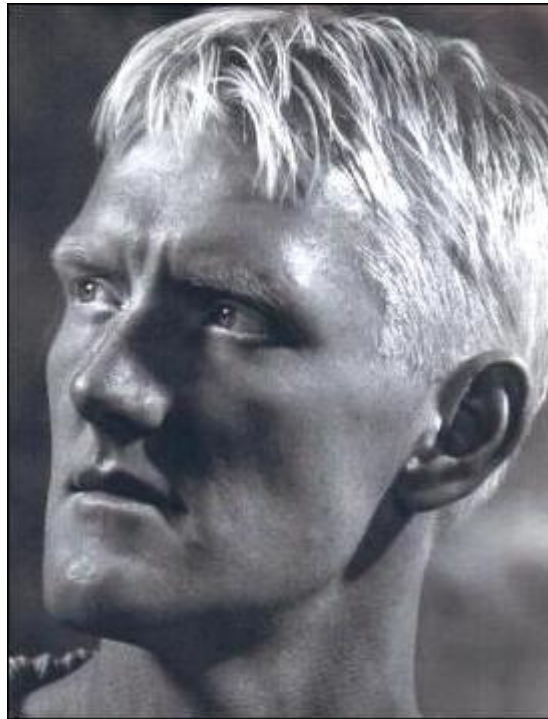

34- WN with some RN. Residual armenisation and mongolisation.



35- Chris J. Evans, English radio and TV host and producer. Highly RN (the hair colour is not to mislead us, as it is an isolated feature, and otherwise his eyebrows, sideburns and probably beard are reddish), with WN contributions, and residual armenisation and mongolisation.



36- Spencer Wells, American geneticist and anthropologist. RN with WN. Not much armenisation, residual mongolisation.



37- Highly Armenid individual from Kiakhta, Kurdistan. Residual WN and Congid contributions.



38- Pure RN.

ACKNOWLEDGEMENTS

I do not want to conclude this important article without expressing my gratitude to those who made its publication possible.

I thank Valg for the trouble he has taken and the patience he had to show me, sceptical at the beginning, all the progress he made in raciology matters. I also thank him for his incredible daily work, meticulously studying hundreds of thousands of pictures and never-ending genetic data from ethnic groups worldwide over many years —an arduous and totally selfless task that will benefit mankind. I am convinced that his work will one day be acknowledged as it deserves. Valg, who is impassioned about biodiversity at all levels, has a blog where he shares his notes and opinions, and that I recommend to visit to know his perspective, which is not always the same as mine.

I have to give a special thanks to a collaboration that has not only helped me out in some tricky biological matters, but has translated the present article from [Spanish](#) to English. This work will endow the classification with a larger diffusion, and from English it may also be translated to other languages (especially Russian, German and French).

For providing some information, I also thank Arminius, anthropologist, who also gave me some interesting references in my [dossier on Eugenics](#).

I also keep in mind all the persons that have indirectly contributed to enrich our knowledge on human biodiversity: photographers, geneticists, models, and

especially the men, women and children who have reached our days triumphantly with their genetic heritage intact.

NOTES/REFERENCES

[1] Physical Anthropology became a solid discipline in the 19th Century, along with the expansion of the European colonial empires, as part of the natural interest in understanding each race and the will to distinguish one from another, both physically as well as psychologically and socially. This discipline reached its peak with Anglo-Saxon and German nordicists and eugenicists, and especially during the Third Reich. After 1945, Physical Anthropology became a "heretical" discipline, it was separated from Social Anthropology (which was completely taken over by cultural marxism and followers of Boasian anthropology and the Frankfurt School of sociology) and was incorporated to the Biology degree course as Biological Anthropology or Bioanthropology. Nowadays there are bioanthropologists who ask for Bioanthropology to be included again as part of the degree in Anthropology, turning it into a shared speciality. This issue is complex, as Physical Anthropology would end up touching social, psychological, genetic, etc., factors, which could take a very politically incorrect path.

[2] To check out the warnings health authorities in America have given to dark-skinned peoples, see the following links:

<http://www.washingtonpost.com/wp-dyn/articles/A43711-2004May20.html>

http://www.usatoday.com/news/health/painter/2009-04-19-your-health_N.htm

[3] The most well-known is probably the Swiss company [Igenea.com](http://www.igene.com) (though its basic test is not very reliable), but there are also more complete tests where, apart from the paternal and maternal lineages, autosomes are analyzed (revealing many things about indirect genetic lines), such as [DNatribes.com](http://www.dnatribes.com), [deCODEme.com](http://www.deCODEme.com) (this more dedicated to the detection of hereditary diseases) or [23andme.com](http://www.23andme.com) (where a more detailed analysis provides percentages —though not very exact— of "European Palaeolithic", "Near Eastern", "Asian", "African" and other genetic contributions).

[4] Sexual selection implies that the social pressures exerted to select a partner on the bases of tribal agreements negotiated by the parents, or on socio-economic criteria, are replaced with a partner-selection based on physical

appearance and attraction. This is the most vivid expression of a purely genetic criterion, and thus of the criterion of the species. Knowing that women are, *under proper conditions* (i. e., a society without artificial products or commercial fads) real machines of instinctive genetic selection, in order to achieve an efficient sexual selection capable of radically changing the genetic make-up of a population for good, two factors are required:

a) To instill a taste for biological quality and racial purity—in other words, for genetics—in the entire population, but especially in women of reproductive age.

b) (Would only work in combination with the previous). Giving young couples in general, and young women in particular, a greater sexual and partner-selection freedom than in other societies, so that the male genetic taste and the female genetic instinct can manifest themselves without hindrance. The consequence would be that carriers of traits considered undesirable would die without offspring, whereas those with desirable traits would have an overwhelming reproductive success.

Ancient Sparta is the best example of sexual freedom combined with genetic taste: parents had no say about their offsprings' marriage and it was only the young couples who decided upon their union, on the grounds of attraction. "Partner changing" was allowed if one of the members within the marriage was ill, infertile or sterile. Vikings are another example: adultery was not punished if it had taken place between a woman and a man who was better than the legitimate husband. Such a social-reproductive strategy tends to improve the genetic make-up of the population, generation after generation.

This contrasts with peoples such as Jews, Gypsies or Arabs, wherein unions are settled with parental consent and are based on sordid tribal, social or economic interests, which means that even paedophilic and/or incestuous marriages are allowed (this happened in decadent Greece) that attack the genetic quality of the lineage. The consequence of this aberrant state of affairs is that the primitive races have been developing beauty and physical attraction at a slower pace than modern races. Today, European races have also fallen into the dysgenic curse of socioeconomic marriage and materialism. In such a state of affairs, a race does not evolve, simply because the finest specimens within such societies have a very high probability of, either breeding with partners who are not up to their genetic level, or marrying much older partners, whose seed is less fresh, so that the offspring will tend to deteriorate rather than improve. All of this is now added to some modern factors (pollution, oestrogenisation, deviant nutrition, alcohol,

smoking, medication, physical inactivity, official enforced ideology, mental programming techniques used by the mass media, and pernicious daily habits) that erode even more the genetic quality generation after generation.

It is also clear that the greater sexual liberty traditionally present in the North since ever (sexual freedom does not mean promiscuity, but choosing whoever you want to have children with; let's recall that within the Germanic tribes, having sexual intercourse before being 20 years old was frowned upon, and that their women were regarded as sexually "pure" compared to the "impure" Roman women), has been used by the modern world against these people, in order to promote mixture and dysgenics among the "white" population —which appears to be very important for the modern system judging by its propaganda. Within a healthy society with good instincts, sexual freedom is the ideal situation, yet in a society dominated by media, money, ceaseless images that give a distorted vision of the world and the human being, materialism, hedonism, comfort, convenience, aberrant fashions, socioeconomic interests and the apology of crossbreeding, sexual freedom is the worst of poisons. Sexual unions under the psychological pressure inflicted by such coercive circumstances, are far from being spontaneous, natural or instinctive, being more alike the unions between third-world peoples, and giving rise to a more and more degenerated progeny.

To sum up, only when people have pure racial instincts, procreation issues can be left up to free-will. Today, we are far from having a population with that instinct; a dictatorship that promotes partnerships based on biological heredity is needed, along with the State-sponsored creation of homes and families of this kind. At least, we would need social systems and institutions to work on genetic grounds and promote the recovery and protection of the legacy of all human races.

[5] Thus, in the Wikipedia [article](#) dedicated to virus, we can read: "In evolution, viruses are an important means of horizontal gene transfer, which increases genetic diversity".

[6] For more information on the genetic flux between Neandertals and Sapiens, before as well as after being confirmed scientifically:

<http://neanderthalis.blogspot.com/2008/04/entrevista-carles-lalueza-fox-sobre-el.html>

<http://www.telegraph.co.uk/science/evolution/6430494/Modern-man-had-sex-with-Neanderthals.html>

<http://mathildasanthropologyblog.wordpress.com/2009/12/04/neanderthals-%E2%80%98had-sex%E2%80%99-with-modern-man/>

http://www.timesonline.co.uk/tol/news/science/biology_evolution/article6888874.ece

<http://www.20minutos.es/noticia/699360/0/humanos/neandertales/africa/>

http://www.elpais.com/articulo/sociedad/Somos/poco/neandertales/elpepusoc/20100506elpepusoc_11/Tes

<http://www.nature.com/news/2010/100420/full/news.2010.194.html> This link is important, as it confirms that the mixture happened essentially in the Near East. The information of this study fills in two important gaps: first, it justifies the cranial models half way between Neandertal and "modern man" found in the Near East (mainly in Israel, but also in Maghreb), and second, it explains certain features of the Armenid race, that arose in that region.

<http://dienekes.blogspot.com/2011/08/adaptive-archaic-admixture-in-hla-human.html> Probable influence of archaic hominids in the genetic make-up of African races.

[7] There are numerous and illustrative examples, such as the Huns, Mongols, Turks, Tatars or Bolshevism. That other oriental occupation which is Zionism, has behaved in a similar way in the Western World with pornography, social politics, [white slave trade](#), nightclubs, the fashion industry, music and subliminal propaganda, with a view to turning Europoid woman into a commercial product and open her to the capitalist market, "globalising", her. This responds well to the desires of primitive races for enslaving the modern ones, acting in a vampirical manner over their genetics and obtaining economical benefits in the process.

[X] For those who repeat the mediatic meme "we're all equal", "races do not exist", "there's only one race, the human", and similar:

<http://www.elmundo.es/elmundosalud/2006/11/22/biociencia/1164217022.html>

http://www.diariocordoba.com/noticias/sociedad/las-diferencias-entre-humanos-son-mayores-de-lo-que-se-creia_285135.html

<http://www.20minutos.es/noticia/175375/0/genoma/humano/diferente/>

<http://discovermagazine.com/2007/may/is-there-a-genetic-basis-to-race-after-all>

<http://www.ncbi.nlm.nih.gov/pubmed/20302945>

<http://mathildasanthropologyblog.wordpress.com/2008/03/05/the-myth-that-all-geneticists-say-there-is-no-such-thing-as-race/>

<http://www.livescience.com/8189-individuals-rare-disorder-racial-biases.html>

<http://jasss.soc.surrey.ac.uk/16/3/7.html>

<http://www.ncbi.nlm.nih.gov/pmc/articles/PMC1448064/>

<http://www.sciencedaily.com/releases/2008/02/080207140855.htm>

<http://content.time.com/time/health/article/0,8599,1993074,00.html>

[X] As many have sent their own portraits to analyse them, I will give some guidelines: the pictures shouldn't be a fashionable pose, you should have a natural and relaxed posture and expression; one full-face photo, a profile one, one half-profile; and there must be a good illumination.