



# Secret History of the Thulegesellschaft

*Nimrod from Rosario*



## EDITOR'S FOREWORD

Everyone who seeks the truth about this world, will discover at some point in his life: gnosis, either through esoteric schools, religions, information on social networks, etc.. But only a few reach the primordial source, which is the Hyperborean Wisdom. The present book is part of that Wisdom and was published on the Internet several years ago. It was written on a typewriter and then scanned in PDF format, that was the first version accessible to the general public. Later an improved version appeared, which was the same, only the text was faithfully transcribed in digital format and the graphics remained unchanged.

This literary work is part of a series of books, of which the first was: "The Strange Adventure of Dr. Arturo Siegnagel", a book that went almost totally unnoticed, since it was a first version. The second book that would be the improved and expanded version was: "The Mystery of Belicena Villca". For that reason the author tells us in the Prologue that this is his third book.

It is worth mentioning that the fourth book corresponded to the Psycho-social Strategy Manual, but only a fraction of it was published.

Regarding the present work, it was edited again correcting some transcription errors found in the second version of the same; in addition, the graphics were redesigned using Illustrator. And to improve this book even more, I decided to add some graphics and relevant information, such as images, news, complementary books and others that are indispensable in the study of the Hyperborean Wisdom.

When editing the edition I noticed missing text, although this could be due to the fact that this information could not yet be disseminated. In addition, fragments of the second book (fundamental for initiating the warrior's path and acquiring part of the primordial gnosis) are reiterated, which are considered to be of the utmost importance, such as the extraordinary story of King Nimrod and the Allegory of the Prisoner.

Without needing to add more to the subject, I give you as a reader the opportunity to immerse yourself in a history of remote times, beyond even the origin of man and his spiritual fall that is expressed today in the decadence that humanity suffers. A story that linked, inexplicably for reason and logic, several characters from different eras. This book comes to be the step to follow once the reading of "The Mystery of Belicena Villca" is concluded.

*Enrique Flores Aruquipa*

**Publisher**

## BOOK III

### THREE LECTURES BY KURT VON SUBERMANN ON HYPERBOREAN WISDOM AND THE S.S.

#### FOREWORD

I have gathered in this third book the contents of three of the four dissertations that Uncle Kurt made for me, on the most secret subjects that can be conceived. It is necessary, however, that I expose them here because, without sharing this knowledge with the reader, it would be useless to continue later with the history of Belicena Villca, which is my own history. If I were to proceed otherwise, the subsequent events would be totally incomprehensible.

We must remember that my trip to Catamarca was for the purpose of obtaining precise information about the SS of the German Third Reich. I believed then that this information would help me to solve the mystery of the Druids, whose presence in Salta to liquidate Belicena was for me, who had seen the bejeweled rope, an undeniable reality. But as I met Uncle Kurt, I discovered that my unusual adventure was part of a greater reality, of which he was also a part. Thus, guided by his entertaining story, I followed the steps that led him to the highest level of Germanic leadership and also to its deepest secrets.

When he reached this part of the story, uncle Kurt unfolded, as has been said, his explanations in four dissertations that would correspond, according to him, to the main lines of thought that Konrad Heine developed in the old house in Berlin, as knowledge prior to the hyperborean initiation.

According to Uncle Kurt, in order to be in a position to UNDERSTAND the inner constitution of the SS, its origins and esoteric objectives, one must FIRST obtain a formidable amount of information. This condition is indispensable, since the SS is but the external, visible appendage of an invisible organic force which starts as such, many centuries ago, but whose hidden genesis must be sought millions of years in the past.

This "invisible organic force" is a Secret Society, or rather, it is a succession of three "societies" of which only the first one can be considered "Secret". We will briefly explain this concept. The conception of a Black SS Order has emanated from the Thulegesellschaft. The Thulegesellschaft was formed by men of the Germanenorden. And some men of the Germanenorden came from the SAPIENS DONABITUR ASTRIS (S.D.A.). But it is not only a matter of highlighting some men or emphasizing some superficial linkage between Secret Societies. That would be a mediocre criterion and, of course, totally wrong. The "truth", from which all analyses must start, is the following: THERE IS A HYPERBOREAN WISDOM WHICH HAS BEEN TRANSFERRED FROM

This is a "truth" that can be verified just by looking at its historical consequences: the SS and the Third Reich. For the line that Uncle Kurt emphasizes, SS, Thulegesellschaft, Germanenorden and S.D.A., is really the one by which terrible ancient secrets reached the present.

We have already said that it is impossible to approach the interpretation of the SS without possessing important prior information. Let us now see how to access it.

I have divided Uncle Kurt's first dissertation into two parts which constitute the first two chapters of this third book. It is a comparative study of the Thulegesellschaft and the Secret Societies of the Synarchy. This is followed by the secret history of the Thulegesellschaft which, because of its length, I have had to divide into chapters. This is the second dissertation. Finally I have divided into two chapters the brief but highly esoteric third dissertation, where the secret history of Heinrich Himmler and the SS is told.

About the fourth dissertation I have to say that, since it is a SS-print entitled MANUAL OF PSYCHOSOCIAL STRATEGY, on which Uncle Kurt only made a few brief reflections, I have decided to add it separately as a fourth book. But I will return to this subject in the respective foreword.

Everything I have transcribed in this third book is, like everything before it, an almost literal reproduction of Uncle Kurt's words, and I have even repeated his brief quotations from some fairly common literary sources. This fidelity has led me to sacrifice somewhat the literary form and to abuse the declensions of the pronouns. I have also changed, after the second chapter, the grammatical person, often going from the first singular to the third plural. These stylistic faults have a simple explanation: Uncle Kurt showed a superlative respect for the memory of Konrad Heine, who was his instructor at the Thulegesellschaft and, for this reason, when he dealt with a subject whose knowledge he had gained by

his intermission, he would automatically speak in the plural. He used to say in those cases "... WE KNOW that the Kassites were hyperboreans and ... etc.", using the plural "WE KNOW" in some allusion to Konrad Heine. On the other hand, he changed the grammatical person when saying, for example, ... "IT IS understood, then, that the Kassite priests WERE also called Cainites... etc."

Instead of repairing these serious stylistic faults by modifying the original narration, I have preferred to preserve the freshness of that marvelous oral prose that Uncle Kurt displayed in Santa María de Catamarca. In this way, perhaps the suggestive implications of his sentences and propositions, charged with metaphysical sense and CONFORMED according to THAT WAY OF THINKING which he called Hyperborean Wisdom, can be better grasped.

It is a long road that I propose to travel in this third book, but it is part of the one I traveled myself when I left for Catamarca to find out the truth about the SS and the Druids. And, I must tell you now, it was thanks to the knowledge obtained at the end of this road that I was able to continue the adventure I started in Salta, when Belicena Villca was murdered.

It only remains for me to make a warning: it is necessary to read these pages with a spirit devoid of dogmas and prejudices. If this is done, then its contents, like a cup of ambrosia, will be drunk with the eyes and will irrigate the spirit with the nectar of the Hyperborean Wisdom. If it is not read in this way, then it will be as if one were trying to eat an indigestible delicacy and, like a hard CHIQUIZUELA not well cooked nor better chewed, the text will drag sharp bones that will tear the throat and burden the stomach. In the latter case, I refer the reader to the warning that, as a prologue, I inserted in the first book:

**"READER, THINK THAT IN READING THIS BOOK YOU ARE STEPPING ON A LAND RARELY HO- LLED BY OTHERS..."**

**DR. ARTURO SIEGNAGEL**

**POST SCRIPTUM:** *It is important to remember that throughout this third book, the voice of the story is always Uncle Kurt.*

## **FIRST LECTURE**

# **SECRET SOCIETIES AND THE THULEGESELLSCHAFT**

## **PART ONE**

The Thulegesellschaft admitted acolytes from different social strata constituting more or less secret CLOSED CIRCLES, each one embarked on the study of an aspect of "GERMAN LITERATURE, HISTORY OR ART" (such is the description of the aims of the Thulegesellschaft in a brochure of 1919) and evolving in the respective theory, by meditation, research or transcendent revelation, until exhausting the intellectual possibilities of this or that idea. There was thus a whole range of Closed Circles composed of human groups of different spiritual levels, from the highly esoteric ones like the CIRCLE OF THE POLARS, led by Professor Horbigger, to the purely frivolous ones like the WEDNESDAY SOCIETY, to which Dr. ALBRECHT HAUSCHOFFER, Ambassador ULRICH VON HASSELL, Professor DR. JENSEN, General BECK, etc. belonged. With reference to this last "closed circle", quite open by the way, I cannot but recall a principle of the Psychosocial Strategy which says "peripherality, inasmuch as it implies moving away from the center, favors contact with foreign circles" since consequently this circle betrayed Germany and the Führer from 1938 onwards by yielding to the harmful influence of the elementalwesen and spying for England on the Allied Powers.

In that year 1937, the Thulegesellschaft had permeated the entire intellectual body of Germany with its closed circles, so that there was practically no official or private scientific body that did not include members of the Order. Just as the N.S.D.A.P. permeated the entire social body of Germany, the Thulegesellschaft - the hidden counterpart of the N.S.D.A.P. - extended its circles to the entire thinking society of the Third Reich.

Certain closed circles which, because of their scientific character, required a special infrastructure and the consequent support of the State, became virtually "exoteric circles" and were henceforth assimilated as official organizations, continuing, however, with their secret research. In the SS, for example, several of these circles were externalized, such as the AHNENERBE INSTITUTE, which was promoted by the SS.

by Dr. Rosenberg and the SS who organized Ernst Schaeffer's expedition to Tibet (OPERATION PAMIR) or the RACE AND COLONIZATION OFFICE under WALTER DARRE, member of the Thulegesellschaft and author of the enlightening book BLOOD AND SOIL.

It is understood that such disparate circles, each advancing its own particular theory and closing around this or that occult ideology, generated a kind of circumscribed fanaticism that made it inconceivable that "contacts" could take place between closed circles without causing serious conflicts. For this reason, the internal security measures of the circles were extreme, sometimes resulting in the case of true "watertight cells" due to the hermeticity of their procedures. In the light of these incomplete references, it could be inferred that the Thulegesellschaft was organized on the basis of a cellular system such as the one favored by the Communist Party to subversively undermine the Western Democracies; but such an assessment would be an error and a gross simplification of the most powerful and best assembled Secret Society in History.

The Bolshevik cellular system is "vertical" in terms of hierarchy and "triangular" in terms of security. Its strength lies in the phenomenon of "mesh" which makes it possible to clandestinely structure hundreds of "cells" by appealing to the security provided by the fact that in each cell there is only one member who has a higher "contact". For the sake of clarity, let us see how a mesh is formed elementary: see fig. 1.

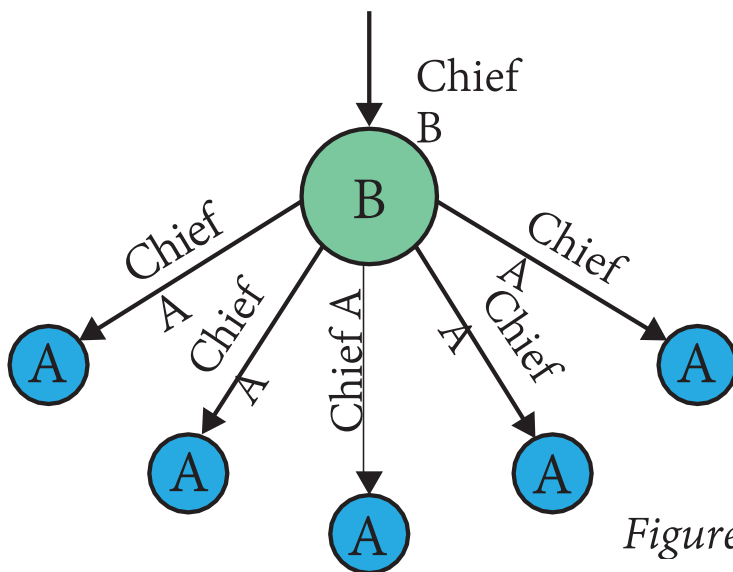

Figure 1



A cell "A" has, say, seven members and one leader, the only member who has the "contact". Let us suppose a cell "B", formed by the chiefs of five cells "A". Here five chiefs coordinate in a cell "B" the control of 35 men. In cell "B" there is a sixth man who acts as head of the group and knows the superior "contact". Let us now assume a cell "C" consisting of three heads of cell B and one head of cell "B".

fourth male head of cell "C", etc. See fig. 2.

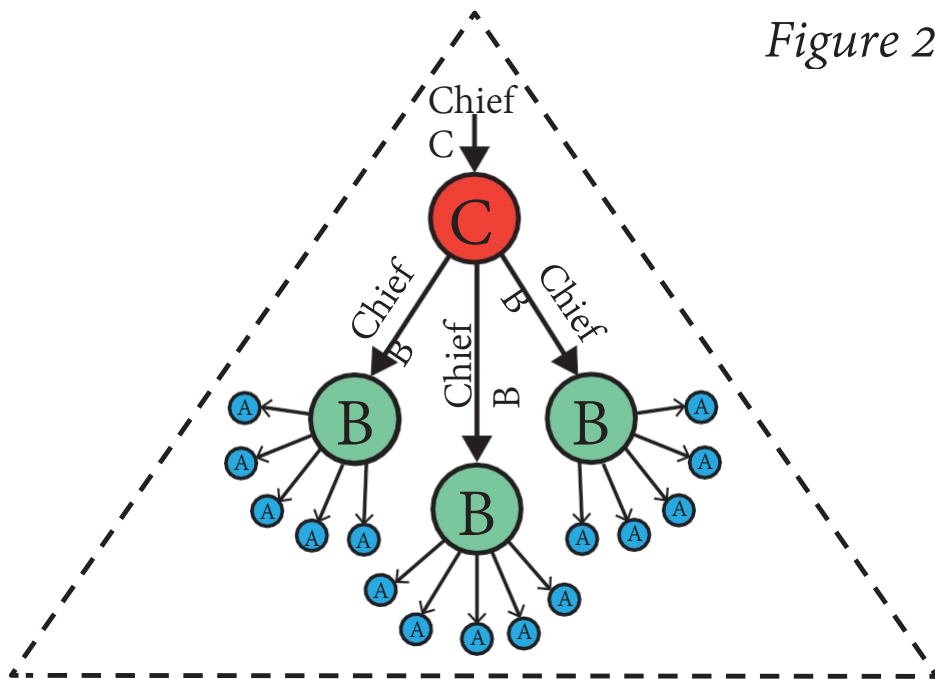

Figure 2

It is elementally proven here how four men control one hundred and five bases with a certain degree of security.

There are many variants in the cellular system according to the purpose pursued by the clandestine organization. If security is to be increased, for example, a "univocal link" can be established by arranging for each "A" leader to receive instructions through a "flying contact" with cell "B", so that the "A" leaders do not know each other, etc.

In a clandestine cellular organization - regardless of its objectives - it must operate according to the principles of military INTELLIGENTZIA, but bearing in mind that clandestinity presupposes the consideration of certain special laws. For example, there is a directly proportional relation between the

The "security" and the "transit time of information", so that "the more security, the more delay in communications". In a movement that must act under official repression, this law becomes visible when, for security reasons, contacts are made indirectly, for example, through hidden mailboxes, which painfully delays communications between leaders and cells.

Considering these elementary principles of the cellular system, I can assure you that the Thulegesellschaft and its closed circles functioned on the basis of ESSENTIALLY DIFFERENT laws and principles. A hint about this intimate constitution had already been given to me by Rudolf Hess that night in the Chancellery when he suggested to me to STRESS THE CIRCLE. But, since I started my visits to Gregorstrasse 239, I could intimately understand the incredible "organization", so to speak, of the Thulegesellschaft. That is why I insist on establishing the differences very precisely.

It seems that between 1919, the official founding date, and 1923, when the first green-bonnet lamas arrived in Munich, the Thulegesellschaft was organized on a vertical and cellular basis, similar to Freemasonry. It was at that time, 1923 to 1926, that a "revolution" took place in the internal structure of the Order (with the departure in 1923 of Baron von Sebottendorff), giving rise to the "new" (very old) circular organization that was to function until the end of the war. The memory of its previous functioning remained from that period and, in fact, few noticed the change. There was a purge and numerous defections, but internally the secrecy became more hermetic than ever.

The reasons for this change were two, which will be seen in detail in the following account; one secondary and the other primary: the secondary reason was a "pact" concluded in 1923 with a certain LHASA order of lamas. The primary motive, and undoubtedly the key to the whole story, is the fact that the Führer managed to READ PSYCHICALLY in 1922 a very old book which the GERMANE-NORDEN, mother of the Thulegesellschaft, had possessed since 1904 and which no one, not even the greatest philologists of the Reich, had managed to decipher.

But, you may ask, what was the system of closed circles? To decipher it, it is not possible to use "geometrical analogies" as in synarchical organizations (e.g. "triangular and vertical"). At least not "Euclidean analogies", since here more than three dimensions would be involved. It will be seen why: when speaking of "circle" (closed, internal, external, etc.) what is done is to allude indirectly, "induce" is the word, to something that is not named but that the word "circle" implies. This "something" implied by the "circle" is the CENTER. And here comes the original, the unbelievable or, if you will, the irrational: all the members of the

multiple circles, claimed that the center, THEIR CENTER, was the Führer.

Perhaps, if one does not meditate on it, one does not immediately understand the ANORMAL character of this statement. For this is not a doctrinaire or dogmatic "idea" common to all members of the Thulegesellschaft, but a REALITY experienced by all and undoubtedly true. That is: in multiple circles, without contact with each other, by people who were also strangers to each other, the strange phenomenon occurred that they all perceived the SAME CENTER around which they were organized. Think what this means: many circles and a common center.

What geometric analogy does it suggest? It will be said, without thinking: a sphere. And the answer will be negative, because the aforementioned closed circles are DISPLACED IN SPACE. Nevertheless, they retain the property of having a common CENTER.

"Then the center is not in this world," may be a hasty conclusion. Well, there is some truth here. But, let us not forget, the center is the Führer. Which would mean "something, which is not in this world, there is in the Führer, perceived by all as the common center of the closed circles of the Thulegesellschaft". Absurd? No more than many dogmas and customs that we profess and accept on a daily basis.

Let us continue with the analysis. It is well known that, outside the three current dimensions, the imagination presents serious difficulties in representing, for example, a fourth or fifth dimension. This is the reason for the incomprehensibility, indeed the "unrepresentability", of the above statement. But, if we accept that the "closed circles", as formed by viryas, have a concrete manifestation in this world and that only ONE PART of the problem is analogically IRREPRESENTABLE, the question of the common center; if we accept this, I repeat, we can try to use an ANALOGICAL MODEL. That is to say, if we are in the presence of a phenomenon whose manifestation occurs in several dimensions, there is no difficulty in "visualizing" that part which affects us sensitively in our concrete world; that is to say, that "aspect", that appearance of the phenomenon, which we perceive sensorially. The "other part", that aspect which escapes our perception, but which is abstractly apprehensible by reason, insofar as it is capable of establishing a mathematical (not geometrical) analogy of the phenomenon, IS INTUIBLE, BUT NOT REPRESENTABLE, except BEYOND reason.

With these precautions in mind, I propose to consider the following model, which will allow us to  
as I have already said, will visualize part of the problem.

Let us assume a space coordinated by three orthogonal axes, X, Y, Z (fig. 3). The plane (Z, X) is the "place" where the human "organizations" are represented, fig. 4. This representation is "direct", by analogically similar geometric profiles. For example, a vertical and triangular "synarchic" organization, already described, will have a "triangle per profile" (fig. 5).

In this model, the MOST GENERAL REPRESENTATION of human organization is the CELL (family, association, etc.); and within the FAMILY OF ALL CELLS, those that are MORPHOLOGICALLY INDETERMINATE. (fig. 5).

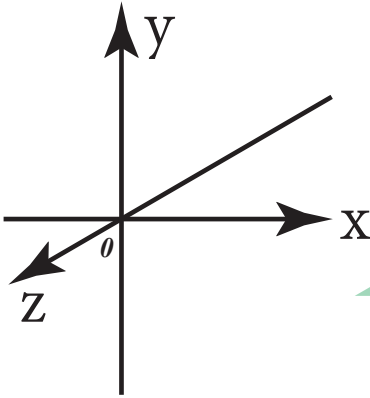

*Figure 3*

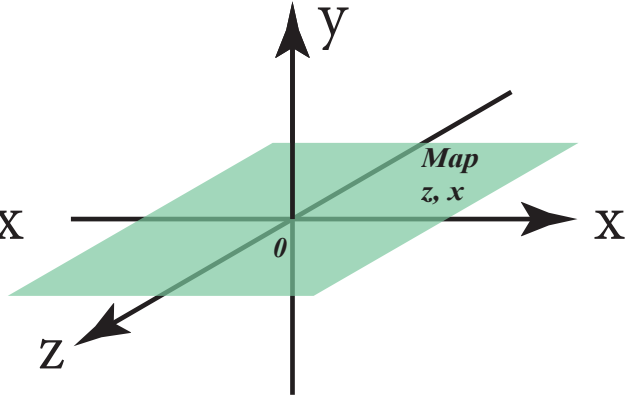

*Figure 4*

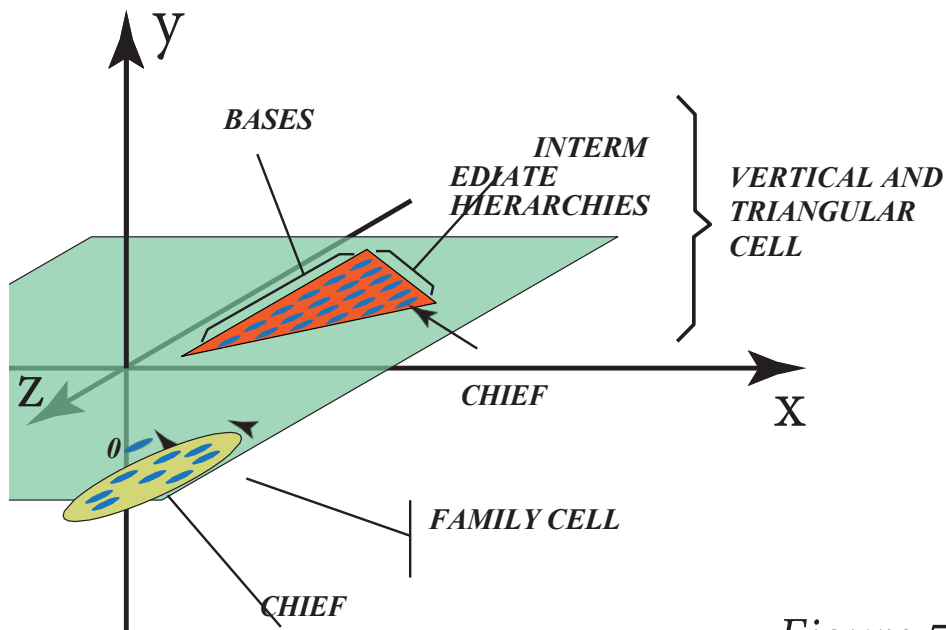

Figure 5

Let us take a closer look at this concept. For a cell to exist there must be three basic conditions: plurality of members, common objective (END), and coincidence on the MEANS to fulfill the common objective (integration). In every cell there are natural roles (leadership or command, logistics, security, welfare, planning, etc.) which, as long as they are rigidly and permanently occupied, DETERMINE THE CELL MORPHOLOGY. The MOST PARTICULAR case of MORPHOLOGICAL RIGIDITY is that of a official army, which will always have a vertical and triangular profile.

A bar of friends, meeting once a month to have fun, also conform a cell (they fulfill the three conditions) but, as the roles are not "covered", or there is "rotation" of roles (for example, a different "boss" in each outing), a MORPHOLOGICAL INDETERMINATION is caused, which is the MOST GENERAL case of analogical representations, and means that such a cell can adopt ANY SHAPE.

Returning to the representation of a vertical and triangular cell, a typical case of synarchic organization, it can be seen in Figure 5 that the profile is effectively a triangle.

If we have understood what has been said up to this point, we can approach the representation of the "closed circles" of the Thulegesellschaft. For this we must reason that, if to a triangular cell corresponded a triangular profile, to a circular meeting will correspond a circular profile.

Let us suppose, for greater ease in the analysis, that any "closed circle" has a profile equal to a geometric circumference, and let us remember that in such a figure "the points of the perimeter keep a FIXED DISTANCE (or radius) inside". But closed circles, as we have already seen, have a point, the center, "outside" of them. This condition causes that, from wherever that point is, it keeps the geometric relations of the fixed distance or radius with each point of the profile circumference. And this condition leads us, reasonably, to suppose that the profile circle is the base of a CONE whose vertex is the center that is "outside of it", that is, that it is an ANALOGICALLY TRASCENDER CENTER.

In the Hyperborean Wisdom this virtual vertex is called the CHARISMATIC CENTER and is considered to be "located" in the plane of the Hyperborean Siddhas, which is temporarily DISINCRONIZED with the material world of the Demiurge Jehovah Sa- tanas (fig. 6).



Figura 6

Compare now the triangular synarchical cell and a closed circle of the Thulegesellschaft and you will get an idea of the irreconcilable differences between both "organizations". I will note, in six comments, the main conclusions to be drawn from such a comparison:

**FIRST** - The triangular synarchical cell has no transcendence outside the physical plane X, Y, Z. The closed circle has its highest authority, the Führer, illuminating the centers from the plane of the Siddhas.

**SECOND** - The hierarchy is vertical (horizontal in the drawing, fig. 5) in the synarchic cell, and depends only on the echelons of power. No matter how these steps are occupied (by inept, climbers, careerists, Jews or simply criminals, etc.), the iron law of the vertical structure is "he who is below obeys he who is above". In the closed circles, the only hierarchy is to the Führer. Among the members, the CAMARaderie rules. Depending on the "social façade" that the circle must fulfill, there can be a relation of organic hierarchies for the profane, exoteric view; but internally all are KAMERAD, that is to say gentlemen with equal duties and rights. ONLY THE AUTHORITY OF THE FÜHRER IS NOT DISPUTED.

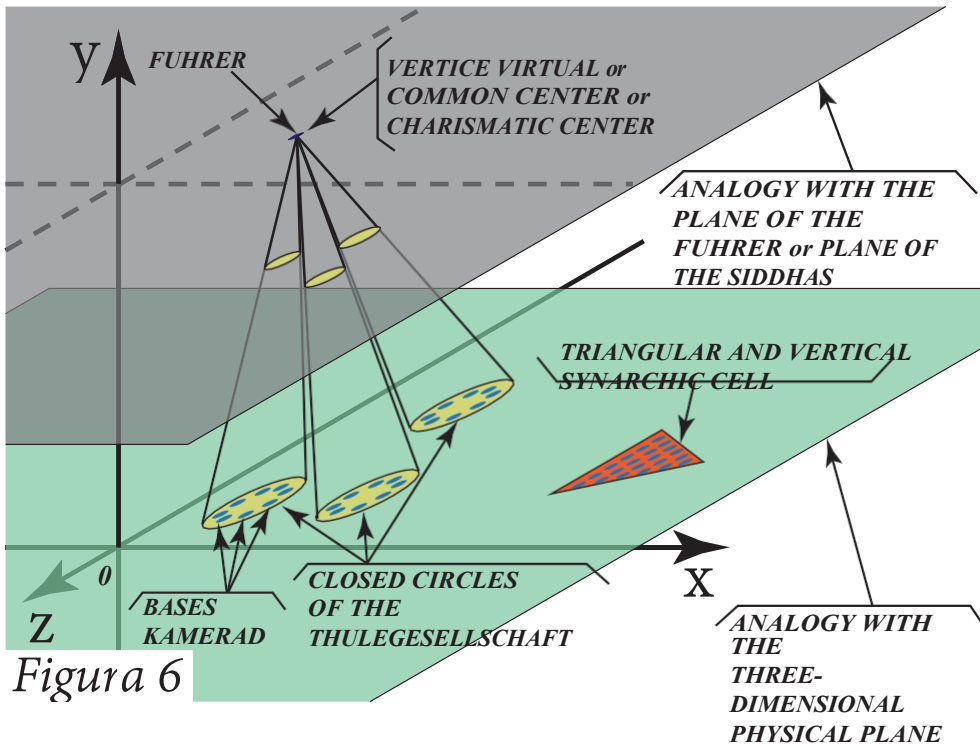
**THIRD** - In the synarchic cell it is necessary for the bases to look literally upwards (in the drawing it would be from left to right, horizontally, in the sense of the X axis) to visualize the maximum hierarchy (general, pope, high priest, rabbi, etc.). In other words, an EXTERNAL, sensory gaze is required, with all that this profane search implies: TIME -it may take time to locate a hierarch of the Synarchy-, SPACE -it may be necessary to move around to locate a hierarch of the Synarchy-.

In a closed circle, the comrades must look INWARD to visualize the Führer, the only hierarchy on earth. Neither time nor space is required, for the "charismatic linkage" effected by the Führer from his charismatic center, common to all in the synchrony of events, is immediately intuitive through the blood Minne.

**FOURTH** - The "progress" in a synarchic cell occurs "through time" (advancing from left to right along the X-axis, which also represents the "sense" of time), climbing the lines of the triangle and trying to reach the apex. It is a purely illusory "material progress", which only means a relative change in the social position within the cell. The position in the hierarchy bears NO RELATION to any spiritual value of the candidate; for example, a man may be able to climb up the triangle by climbing the lines of the triangle and trying to reach the top.

The "ascending" of hierarchy, which means that he is materially "superior" to his subordinates, but at the same time, if he committed a crime in order to ascend or climb, he may be spiritually "inferior" to those he commands. PROGRESS IN A SYNARCHIC CELL IS, IN ALL CASES, EVOLUTIONARY.

In a closed circle of the Thulegesellschaft, figure 6, one neither moves forward nor backward definitively. It could be said that one turns in CIRCLES OF ETERNAL RETURN, but this idea, as we shall see below, implies much more. The "progress" here, if one wants to use such an equivocal term, is given by the possibility that the virya possesses of recovering the memory of blood, the Minne, and transmuting himself into an immortal Siddha, into a divine hyperborean. Nothing binds the virya to the illusory world of Je-hova-Satan other than his chromosomatic confusion, his blood impurity that keeps him temporarily lost for the hyperborean race of Christ-Lucifer. His goal is outside time and space, set only on RETURN and immortality. PROGRESS IN A CLOSED CIRCLE IS, IN ALL CASES, MUTANT.

**FIFTH** - Finally, it should be borne in mind that the synarchic cell is the most suitable organization for the development of the pasu or animal-men, who, due to their eminently logical mental constitution, believe they PROGRESS AND EVOLVE in their movements through the hierarchic triangles. The pasu, as we will see later on when studying the Psychosocial Strategy of the SS, lacks "hyperboreal lineage"; that is to say, he has never possessed the Vril, and therefore does not possess Minne sanguineous. He is, with all precision, a MENTAL CREATION OF JEHOVAH-SATANAS, a pure illusion. For the Hyperborean Siddha the pasu DOES NOT EXIST, says the Hyperborean Wisdom. However, in the illusion of SAMSARA, of the becoming of the world, the pasu possess a RELATIVE EXISTENCE facilitated by Jehovah-Satan.

Confused with the pasu are the hyperborean viryas, semi-divines, towards whom the action of the Führer and the Thulegesellschaft is directed, in the search for the double effect: "to obtain the collective transmutation (we shall see that "collective" must be given another meaning in the Hyperborean Wisdom) and to put an end to the Kaly Yuga or Dark Age.

For all these reasons, it must be considered that it would be "impossible" for a pasu to integrate a closed circle of the Thulegesellschaft because, lacking "blood memory" or Minne, he would be prevented from perceiving the "center", that is the charismatic bond of the Führer, and therefore "since there is no center there is no circle", that is to say that THE CLOSED CIRCLE DOES NOT EXIST FOR THE PASU.



**SIXTH** - To all that has been said it could be added, as an illustrative fact, that the marvelous organization of the Thulegesellschaft in closed circles, as we have seen it here, was still surpassed after the War by the Anael Order of Latin America, founded by the Siddhas in Brazil, Argentina and Chile in 1946, and which still functions in the most perfect hermeticism. The overcoming is due to the fact that, not existing this time the need to institute "many circles" as in the Third Reich, it was proceeded to build a single circle as in figure 7.

There, each bar A, B, C, ... etc., is a watertight cell (political, military, esoteric organization, etc.) representing the "spokes" of a wheel (of Surya's chariot, says the Hyperborean Wisdom); but in which the "center of the axle" is in the plane of the Hyperborean Siddhas.

Thus, instead of base comrades as in the "closed circles" of the Thulegesellschaft, there are BARROTS of the Anael Order forming a "closed circle of power". In the center of that circle, due to the MOMENTARY ABSENCE OF THE FÜHRER, the Siddha Tulku Julio César Urien Grieven from Argentina, a man who gathers in his blood two very pure hyperborean lineages of BASQUE and SAXON origin, fulfills his function as "terrestrial center". The Führer, in any case, as a Siddha in-

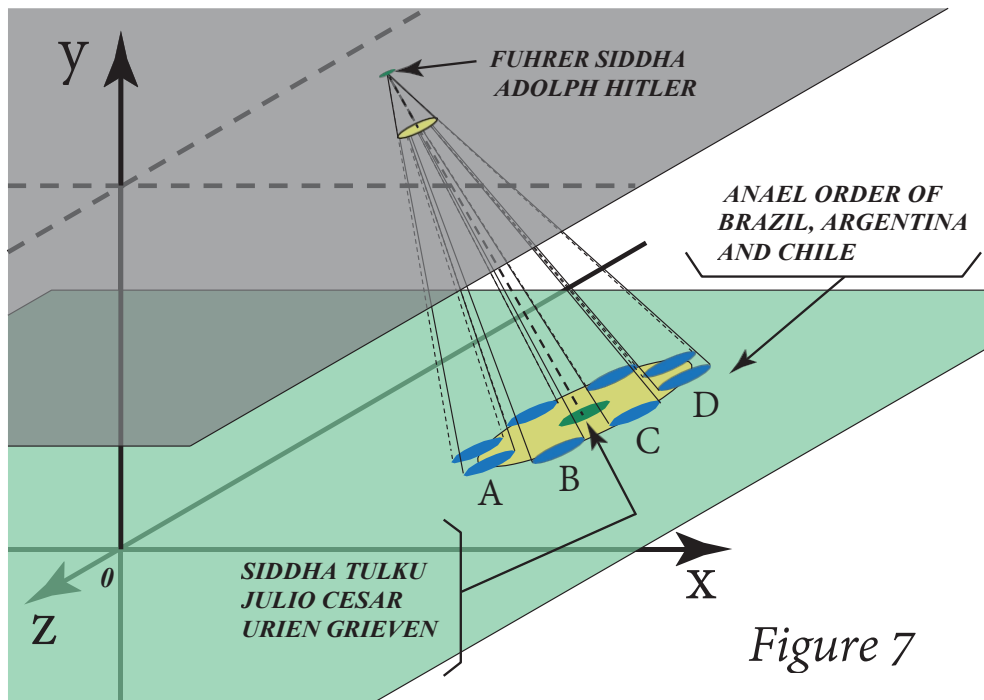

Figure 7

charismatically illuminates the Siddha Tulku Urien Grieven from his abode hyperborea in the Valhalla of Agarta.

With these six comments and the observation of the analogical model, one will have an idea of the essential difference between what we call the typical synarchic Secret Society and the CIRCULAR CONFORMATION of the Thulegesellschaft.

*Sinarchy: The true and scientific meaning of the word "Sinarchy" is the so-called Universalism or Universal Government, through the conjunction of political power with the forces of international financial and economic capitalism, which destroy the culture, personality, life style, ethics, morality, work, family, peace, etc., of the different peoples, taking over their means of production, their intermediation, their banking, their oral, written and visual communications, their culture, etc.*

FIRST LECTURE

**SECRET SOCIETIES AND THE  
THULEGESELLSCHAFT**

**PART TWO**

With the reservations of the case, attending to what has been said up to now, we will call the Thulegesellschaft a "Secret Initiatic Society", because in the closed circles, up to the "penultimate circle" the "Hyperborean initiation" was granted to certain members. This ceremony after 1933 became the exclusive use of the SS and from 1936 was only performed in the SS castle of Wewelsburg, which gives an idea of the importance that the Thulegesellschaft gave to

Heinrich Himmler and the SS.

*The symbol of the Black Sun in the Hall of Wewelsburg Castle.*

*...Giant "crop circle" in the shape of the Black Sun, at Ox Dro- ve, near Bowerchalke, Wiltshire, UK. Reported on August 8, 2015. In numerology, 888 (August 8 [eighth month], 2015 [2+0+1+5 = 8]; Adolf Hitler's symbol is 88 [Heil Hitler = HH = eighth letter of the alphabet, twice = 88]....*

Since I received this initiation and would like to speak about it, I find myself in the same case as above when I begin to describe the circles of the Thulegesellschaft. We must also differentiate here what is meant by "hyperborean initiation" and not confuse it with the "synarchic initiation" given by the Synarchy in its theosophical and Masonic schools, intended mainly for pasu and lost viryas.

In order to clarify these concepts, it is convenient to start at the beginning and analyze the initiatic Secret Societies of the Synarchy, and then move on to study the Thulegesellschaft.

When considering the history of Secret Societies, a distinction is usually made between Initiatic Secret Societies and Political Secret Societies, according to their transcendental or temporal character. For this classification, "the aims" of the Secret Society would be taken into account, understanding that the search for a purely temporary objective such as "the seizure of power" or the triumph of a "subversive" ideology or the administration of justice "by one's own hand" in times of crisis, etc., correspond to a Political Secret Society.

History records numerous Political Secret Societies that would come to form classic examples: the HOLY VEHME in Germany, 14th to 19th centuries; the ILLUMINATES OF BAVARIA, 18th to 19th centuries; the CARBONARIANS in Italy and France, 19th century; the UNITED IRISH, the SINFEIN and the IRA, in Ireland, 17th to 19th centuries; the KU-KLUX-KLAN in the United States, 19th to 20th centuries; and the MAFIA (Criminal Secret Society but also "Political") in Sicily, USA and almost all the western world, 18th to 20th centuries; etc.; etc. They would also belong to the MAFIA (Criminal Secret Society but also "Political") in Sicily, USA and almost all the western world, XVIII to XX centuries; etc. A multitude of Death Squads and similar paramilitary organizations would also belong to the political branch, and even Marxist or TROTZKIST organizations that move in the underground.

It is asserted, in establishing the above distinction, that the triumph or achievement of the declared objectives automatically extinguishes the Political Secret Society: a clandestine organization, whose sole purpose is to favor the seizure of power by a group of conspirators, loses its *raison d'être* upon the triumph of the revolution. The appearance in history of many Secret Societies (some of those named and others) would seem to support this criterion, which, according to Konrad Heine, is completely erroneous.

There are, yes, Secret Societies with strictly political objectives, but their number is minimal and their existence ephemeral. On the other hand, many of the classical Political Secret Societies, whose activity extends over centuries, either hide their initiatory character, or are linked to an Initiatic Secret Society. This is the true hidden lung that breathes the vital energy of some "mysticism", since faith in something transcendent is the only "secret" to last for centuries. "There is no social or political claim that is not purely secular, for every righteous claim disappears with the generation that raised it."

IT MUST BE CONSIDERED THEN THAT EVERY POLITICAL SECRET SOCIETY OBLIGATES IN ONE WAY OR ANOTHER TO AN INITIATIC SECRET SOCIETY, AND - except for the AUREA CATENA that we will see later- ALL THE INITIATIC SECRET SOCIETIES, AT LEAST IN THE TWENTIETH CENTURY, CONSTITUTE THE INTERNATIONAL SYNARCHY, THEIR TACTICAL DEPLICATIONS.

We have seen that the distinction between Initiatic Secret Society and Political Secret Society is erroneous, or at least insufficient. But what is an Initiatic Secret Society, of whom we say that the Political Secret Societies obey it and to whom we attribute the shaping of the tactical structure for the strategic action of the Synarchy?

Let's look at the issue in detail in parts.

A SOCIETY is a human group gathered to fulfill a common objective. A SOCIETY is SECRET if the objective (END) sought or the MEANS necessary for it must escape public attention (the END may not "morally" justify the means). But a Secret Society can also be official or clandestine, according to the following law which is deduced from the fact that between the "spirituality" of an organization and the official Power there is a directly proportional relationship: "The closer a Secret Society is to Power, the more exoteric (less esoteric) its internal doctrine will become.

This law indicates that, for the purpose of preserving a certain spiritual heritage, clandestinity is always desirable and gives the guideline that an authentic "Esoteric School", if there is one, should be almost inaccessible to the profane.

A Secret Society is INITIATIC when it knows itself to be the bearer of a Mystery and regulates access to it by means of a ritual ceremony that transforms the "profane" into an "initiate".

It is understood that the title of Initiatic Secret Society is only given to those whose "secret" knowledge is esoteric and spiritual. We must, therefore, first analyze what is understood by "initiated" and by "esoteric" before we face a definition for the Initiatic Secret Societies.

The word "initiation" (INITIUM) derives from two Latin words: IN = in; IRE = to go; that is: beginning. The initiate, in general, is the one who begins something and in the particular esoteric case "is the one who begins a new life".

Initiation implies, then, a radical change in the life of the initiate. This has always been so and we can verify it by analyzing the fact of RITUAL INITIATION throughout History. Ritual initiation is a long-standing institution in human societies, and its presence can be detected almost without exception in all historical peoples. In primitive societies, even in our days, it is possible to observe initiation rites, called "of passage", to fix the passage from child to man, to his participation in the adult life. It is also common to initiate spouses and future hunters. Particular attention deserves for us the ritual of warrior initiation practiced by the Indo-Germanic peoples since ancient times.

Initiation is thus the initium, the beginning of a new life, whether as an adult, spouse, hunter or warrior. But the theme is one of the most suggestive and needs to be analyzed in greater depth. All these examples show that initiation is an experience of an eminently social character, since initiation can only be administered externally, starting from others, with collective participation. For the phenomenon of initiation to exist, there must simultaneously be the operation of an initiatory community, for initiation (INDIVIDUAL EXPERIENCE) requires an initiatory ritual (COLLECTIVE EXPERIENCE).

We also note that, since its remote origins, initiation is a practice COMMITTED to the society in question, which has favored the passage from profane to initiate precisely because it counts on the participation of the latter in responsibilities that will be revealed to him in due course.

On the other hand, if to be initiated is to begin to walk a new path, this change is by no means easy or pleasant, originating in the forgetfulness of ancient initiatory practices, not a few of the problems of alienation and neurosis that the white race currently endures. Indeed, the passage from "child" to "adult" was made by means of a ritual ceremony that prepared man for various changes that accompany the entry into the new life, among which, of no small importance, are: the abandonment of the mother, the responsibility of contributing to the common nourishment, the certain prospect of death, etc. (when one is a child, a "next stage" is adulthood; when one is an adult, a "next stage" is old age; and when one is old the next step is death. (Likely, the "passage" from child to adult poses among other "changes" that of death). Initiation has the virtue, in this case, of avoiding traumatic sequels by "establishing" with the force of social law that the initiate is tacitly prepared to "begin to walk the new path", which evidently morally supports the candidate.

Among us, the passage to adulthood takes place gradually, due to the lack of the precise and inexorable limit that would be an initiation ceremony; and it involves painful and often traumatic experiences. There are those who never manage to effectively "abandon" the "mother", suffering a sort of perpetual external domination and the consequent internal insecurity due to the psychological dependence created.

When we say "abandoning the mother" we are referring to the "maternal archetype" and we are in no way encouraging a situation of exile from our loved ones. The proximity or remoteness of the carnal mother in no way alters this complex that generates "softness of character" and "sentimentalism", so it is necessary to fully assume all the psychic potential that man has; this will be the first step in the search for individuation.

There are thus men who never cease to be children, and men who never become adults, because of the gradualness of the "passage", lacking the limit set by initiation. This situation has been tending to correct itself in the white race for some centuries with the natural appearance of a NEW AGE between childhood and adulthood called ADOLESCENCE, which is a euphemism for the state of TOTAL IDIOTISM into which the young man falls, for a more or less long time, but which happily has the beneficial effect of attenuating the impact of external changes when the "passage" takes place.

We have already made clear what initiation is in its general meaning. Let us now look at its esoteric meaning.

By esoteric we mean, as the Greek word EISOTHEO indicates, a "making one enter" into the mystery. Therefore, when we speak of "esoteric initiation" we mean a "beginning" (initium) on the one hand, and a "making one enter" (EISOTHEO) on the other. It is well known that, since Aristotle, the esoteric is opposed to the exoteric or profane in the field of knowledge. But this knowledge to which the esoteric alludes is not precisely an "occult knowledge" because of its secret character, but because of its quality of "privileged saber", that is to say, categorically hierarchical.

Esotericism opens a door "to pass" (EISOTHEO) from a profane world,gnoseologically based on false categories resulting from an erroneous perception of the real, which in turn is illusory in its concrete materiality, to another spiritual world of pure metaphysical perceptions, considered, paradoxically, as truly real.



However, the door that esotericism opens cannot be crossed by anyone; not all laymen are qualified to access such "superior" knowledge. The "esoteric knowledge" supposes the "privilege" of its knowledge and requires, therefore, of a "control" in that door that opens to "make enter", EISOTHEO.

This control is precisely the "esoteric initiation" of the profane who are qualified for it, that is to say, of those men who are "initiable".

We have already spoken of ritual initiation and extended ourselves in examples on the "rites of passage", proving that initiation, initium, supposes a permanent change in the initiate who begins, from the initiating rite, "a new life". In esoteric initiation this condition is taken to its ultimate consequence in such a way that the initiate must experience, as a rite of passage to the new life, an AUTHENTIC DEATH AND RESURRECTION. Esoteric initiation is unanimously considered an irreversible experience, so that if the initiate does not demonstrate, in the eyes of his initiators, an authentic transmutation, "he can hardly live to tell the tale".

To understand this terrible statement we must consider the fact that esoteric initiation is a very ancient and universal practice, historically recorded in all known cultures, which is why we have abundant information, especially from the great ancient civilizations where esoteric initiation experienced periods of true splendor.

But in antiquity, esoteric initiation was administered by priestly castes that responded to the official cults of the various peoples, and the deities involved in the rites of the Mysteries were always race gods. Thus we know "Mystery Schools" or "Cults" typically initiatory, possessing a particular religion or myth, often analogous in their symbology, for each people or ancient race. Among the best known we can mention in Egypt: Mysteries of Osiris and Isis; in Greece: Mysteries of Dionysus, Mysteries of Eleusis, Mysteries of Orpheus, the Order of Pythagoras, etc. in Iran: Cult of Mithra, Mazdeism, Manichaeism, etc.; from India and Tibet: Hinduism, Buddhism, Shao-Lin, etc.; from Japan: Shintoism, Zen Buddhism, etc.; from Islam: Sufi sect<sup>1</sup>, Assassin sect, Druze sect, Ansarieh sect, etc.

---

1 *Sufism is an esoteric Islamic movement comprising several sections.*

In all these ancient Mysteries, and many others, esoteric initiation took analogous forms as regards the entrance of the neophyte and his subsequent initiation. It is based on the universal concept that esoteric initiation "IS A PROCESS DESIGNED TO REALIZE PSYCHOLOGICALLY IN THE INDIVIDUAL THE PASS FROM A STATE REPUTED AS INFERIOR OF BEING TO A HIGHER STATE: THE TRANSFORMATION OF THE PROFANE INTO THE INITIATE. BY MEANS OF A SERIES OF SYMBOLIC ACTS, OF MORAL AND PHYSICAL TESTS, IT IS A QUESTION OF GIVING THE INDIVIDUAL THE SENSATION OF 'DYING' TO BE 'REBORN' IN A NEW LIFE".<sup>1</sup>

In this general figure on esoteric initiation, it is worthwhile to dwell on the last quotation marks and also to note the "moral and physical tests" and the "symbolic" acts. The physical tests to which the audacious neophytes were submitted, considered "initiable" after suffering long and vexatious novitiates, generally ended their lives. We will not expand on examples, but it is worth the elementary reference that such physical tests consisted in the confrontation, unarmed or when not drugged, with "sacred" animals of greater or lesser ferocity, such as lions, crocodiles, venomous snakes, etc.

The surviving neophytes then faced "moral tests" which usually consisted of suffering humiliations of different kinds "to demonstrate humility"; resisting the assault of fiery and beautiful priestesses, often after having taken aphrodisiacs under deception, "to demonstrate chastity"; performing certain physical feats such as resistance to pain or fear "to demonstrate organic dominion"; etc. Failure in these moral tests did not necessarily mean death, but the immediate expulsion of the unfortunate aspirant. In any case, this is a general appreciation; since in many Mysteries certain secret teachings were imparted -simultaneously with the novitiate- which were not to be professed, the priests proceeded in those particular cults to execute the unsuccessful one.

Finally, the "symbolic acts" refer to the initiatory ritual itself, which, as is logical, varied from one Mystery to another; but which in all cases had the purpose of producing a psychic unfolding in the neophyte that would allow him to make the transcendent JOURNEY. This "journey", an essential experience to obtain initiation, consisted, according to all references, in the transit of the unfolded "I" through a path of the "other world". Such a "path", which in its fantastic route towards exalted deities crossed, however, infernal abysses plagued with unspeakable terrors, was in every way similar to that which we tread in our "last" "journey".

---

1 *SERGE HUTIN - The Secret Societies - Page 6, Eudeba, Buenos Aires.*

The "thymus journey", the one we all make at the hour of death.

The "return" to life, after the initiatory journey, was the authentic triumph of the neophyte, now initiated, and was interpreted as a true "second birth".

Of the neophyte, of his profane mind, nothing had survived after the initiatory death; the resurrected initiate, on the other hand, was considered a new being, possessing a knowledge obtained BEYOND DEATH.

As an epilogue to this commentary on esoteric initiation, we must consider the influence that the passage of time has exerted on this transcendent experience, from Antiquity to the present day. We shall make this evaluation using a criterion that Konrad Heine constantly repeated to me in those days: History, as we understand it in its documentary sense, that is to say that "it begins for us with decipherable and comprehensible written testimonies, which in different countries correspond to completely different epochs", is nothing more than a part of the Dark Age called by the Indo-Aryan peoples Kaly Yuga, Iron Age or Age of Darkness.

Later we will expand on this concept of History. For now we must consider that these "darknesses", which advance together with History, are intellectual blacknesses that envelop the spirits, gradually depriving them of any transcendent light. This spiritual opacity, which implies the "loss" of metaphysical faculties once common to viryas, has been blamed for the materialistic tendency that civilizations have followed. It has also meant the ruin of historical civilizations, including our present Western civilization, already involved in a crisis of decomposition and cultural decadence.

On this negative slope of history, esoteric initiation has suffered the worst fate. Emerging from a context that we call Ancient Wisdom, it was for thousands of years an effective practice in the priestly function of all civilizations. But the general decadence that in different epochs enveloped the peoples, put an end to the "gnostic content" of the Mysteries. Of course this was due to human decadence more than anything else, for when the eye hardens and the soul dwells in darkness, the Mysteries, which are no more (and no less) than symbols, lose their operative capacity, do not "reveal" their secret to the priests, and all succumb to superstition and myth.

Thus, in a slow degradation, the metaphysical "contents" begin to be lost and their "container", the RITUAL FORM, is exalted to the point of desperation (or fanaticism) in a vain attempt to force the emergence of the metaphysical "content". But it is useless; the living Mystery has been transformed into myth; the ritual is an empty shell of "content"; the initiation is a theatrical representation, all the more wrapped in "mystery" as hollow of spiritual realizations.

It is the Kaly Yuga. Initiation will no longer be "esoteric" because there will be no "door to open" or Mystery to know; but "exoteric", profane, because the priestly function was profaned, without exception, in the last millennia.

However, today we hear talk of "Masonic initiation", "Rosicrucian initiation", "Theosophical initiation", etc., or of Mysteries and Secret Doctrines, which certain modern "schools" would possess, What has happened? Are we facing a restoration of the ancient Mysteries, of the esoteric initiation that transformed the initiate, twice reborn, endowing him with the capacity to dialogue with God? Has the Kaly Yuga come to an end, given the avalanche of "mysterious" and "initiatory" sects coming from the East?

Nothing of the sort. Since the beginning of the Kaly Yuga, parallel to the spiritual decadence and the advance of materialism, there have been surfacing some frightful "powers" whose "seat" is an "occult center" of the Earth from which the will of Jehovah-Satan is channeled. These diabolical "powers" are those that contribute decisively to the falsification into which all the religions, cults and schools of the Mysteries of Antiquity fall, and they are those that in the last century - only recently! - we have been able to distinguish clearly under the denomination of International Synarchy.

For centuries they impelled the Initiatic Secret Societies to replace the Ancient Mysteries or to infiltrate and control the great religions. But the initiation, under the influence of the "diabolical powers", has become pure formula. Of the Living Mysteries and the initial esotericism, only a "symbolic" and "speculative" syncretism remains. The "initiatory journey" made in a psychic unfolding through the "other world" will now be a walk made physically, "symbolically" say the Masonic synarchs, through the courtyards of the lodges.

This is how we arrive at the last centuries of our epoch with a marked accentuation of the decadent tendencies of the Kaly Yuga and, consequently, with an increase in the NUMBER of the Initiatic Secret Societies. The latter are responsible for that "avalanche of mysterious and initiatory sects that comes from

East" we were talking about before.

The "tendencies" of the Kaly Yuga are approaching the zenith and that is why the "diabolical powers" are now manifesting themselves universally through the International Synarchy; and that is also why we can clearly distinguish their actions and understand their sinister plans.

Returning to the subject of esoteric initiation, we can affirm that it has totally disappeared from the West during the last two millennia. The Secret Societies of the Synarchy have nevertheless used such a label for an "exoteric initiation" whose main objective is to nourish their ranks with adepts, sworn to death, for the sole purpose of fulfilling their plans for world domination.

There is nothing in them that favors the spiritual overcoming of the adept, that is to say, the detachment of the ties that chain man to matter and his definitive liberation from the miserable condition to which the material "order" of Jehovah-Satan has subjected him. There may be promises in this sense that only respond to the need to momentarily deceive those from whom it is expected to obtain some benefit.

But the black reality is that no one can pretend to "serve" a Secret Society of the Synarchy, a naivety that pays dearly; but the Synarchy will use as it pleases the unwary or accomplices that populate its ranks and if some will benefit with wealth and power while they are useful, others will be destroyed when they do not faithfully fulfill its designs.

In the ancient Mysteries, initiation was administered by priests, masters or gurus, who watched over the correct completion of the ritual. The initiates, reborn and wise, would eventually replace their former initiators.

In today's Secret Societies, initiation consists simply of an oath of complicity, similar to that which exists in the codes of the underworld, taken by the "apprentice" or "companion" or "brother" when, after a symbolic ritual, the "mystery of the Order" is revealed to him and what is expected of him. This "mystery" is none other than "to know the mission that the Order has in society", that is, its contribution to the worldwide synarchic plan. Once the neophyte has been "initiated", that is to say that he is in the secret of the Synarchy, he must take an oath that will prevent him from ever leaving the Order on pain of "ritual death". The exoteric initiate is,

If he defecates from his lodge, he will be quickly executed; and if he continues in it "progressing in the degrees" and "fulfilling the tasks", his only reward will be material triumph, since, in his innermost being, the spirit will flee from the one who sinks into synarchic Satanism.

Let us make a summary. We said that Secret Societies are usually divided into Initiatic Secret Societies and Political Secret Societies, but that such division is illusory because all Political Secret Societies depend on Initiatic Secret Societies. The latter, together, constitute the MAIN BODY of the Synarchy, still underground, but ready to emerge in the most powerful of all organizations ever dreamed of or seen on Earth: the WORLD GOVERNMENT OF THE SYNARCHY.

We studied ritual initiation and esoteric initiation and found that the Secret Societies of the Synarchy, even though they claim to be "initiatory", do not practice a true ritual of "death and resurrection" suitable for viryas.

These, on the other hand, "initiate" by means of a prosaic "ritual", based on a code of complicity and temporary secrecy proper to the criminal cells they actually constitute. Cells that, due to their vertical and triangular character, are suitable for the pasu and, eventually, the lost virya.

Only the following can be added: The Thulegesellschaft is the only, let it be understood, the only Hyperborean Initiatic Secret Society that has operated in the West in the last 700 years. The "Hyperborean" is due to the fact that the Thulegesellschaft is the depository not of a "Mystery" but of the Hyperborean Wisdom, which is the mother of Mysteries. From this point of view, except for the Thulegesellschaft, all the Secret Initiatic Societies are mere forgeries of the ancient ones, made by the Synarchy.

As the story goes on, this statement, which seems so adventurous, will become evident. To the extent that we understand the Hyperborean Wisdom and its guidelines of criteria, and we represent to ourselves the Plan of Synarchy, we will be able to effect the PHILOSOPHICAL AFFILIATION of many Secret Societies or organizations that WRONGLY DO NOT CONSIDER THEMSELVES SYNARCHICAL.

## SECOND LECTURE

# SECRET HISTORY OF THE THULEGESELLSCHAFT

## INTRODUCTION

It is more or less known that the Thulegesellschaft - the men who founded it - arose from the bosom of the Germanenorden; but everything that is usually speculated beyond this precision, in books and articles published for defamatory purposes, is mere nonsense. There is, however, a marvelous history which makes it possible to trace the origins of the Thulegesellschaft and the Germanenorden back to the 16th century, but it is known only to the initiates of the Black Order, i.e., to the SS leaders; and it has never been publicly revealed until today. This history will now be exposed so that its powerful light may dissolve the darkness of ignorance in which the memory of the Third Reich is shrouded and show clearly the hidden motivations that drove the Führer and his SS leaders.

The first link connecting the Germanenorden with the past is a German Secret Society founded in the 16th century under the name of Sapiens Donabitor As- tris. This last Society survived painfully until the end of the 19th century, which we could call the "century of the Synarchy", to succumb in a metaphysical fall during the first years of the 20th century. But notwithstanding its definitive "synarchic copam- pation", before falling, it succeeded in fulfilling the purpose for which it had been founded: IT TRAINED MEN AND HANDED THEM THE SECRET. Theodor Fritsch, Rudolf von Sebottendorff, Dietrich Echart, etc., are some of the MEN. The SE- CRETO consisted of an armored trunk with steel bars, built in the sixteenth century, which remained in the possession of the Order for three hundred years until the arrival of the times ... This trunk and other elements were finally entrusted to the greatest hyperborean mutant of the twentieth century: Dietrich Echart, the initiator of the Führer. Such is, in a nutshell, the story we intend to tell, the origin of which dates back to the 16th century.

But during the story we will move away from the 16th century many times. We will go backwards in time and space and stop in Assyria, 2,000 years before the present era. Then we will pass briefly in the Sicily of the 13th century, at the court of

Frederick II Hohenstauffen, and then we will stop well into the sixteenth century to travel to England, Spain, America, Flanders ... but nevertheless our starting point will always be the same: the court of Rudolf II Habsburg, in Bohemia. We must not forget Atlantis, because in the course of our story we will often refer to its lost science and its ignored races.

It is possible that someone may wonder if it is justified to resort to remote historical arguments to explain events that occurred in the 20th century. However, all these disparate places and situations, apparently unconnectable among themselves, possess A NON CAUSAL LINK that passes unerringly unnoticed to the synarchic gaze, but that shines and manifests itself royally in that hyperborean relationship that links the viryas on the path of return, in that AUREA CATENA that can only be followed if one has felt the Minne and has committed oneself to participate in the cosmic war. To perceive this synchronistic nexus, we must relentlessly renounce the tyranny of reason, the tool of the pasu, and search in the blood for the ANSWERS TO QUESTIONS THAT HAVE NEVER BEEN ASKED AND NEVER WILL BE.

With this mystical disposition of spirit we will now begin the journey outlined above. We will begin by going back to the 16th century, to the court of Emperor Rudolf II Habsburg, who appears as the remote founder of the Sapiens Donabatur Astris.

This monarch, in addition to being King of Rome, Emperor of Germany and King of Hungary, was King of Bohemia, which is why his main court was located in Prague, one of the most important cities of the time. Addicted to the study of Alchemy and Astrology, these inclinations for mysterious things did not, however, eclipse his immense culture. He was considered a generous patron and was able to gather under his protection numerous personalities. At his court in Prague, he was able to meet well-known scholars such as the astronomers TYCHO BRAHE and JOHANNES KEPLER, as well as esoteric scholars like the alchemist physician TADEO HAJEK "HA-GECIUS", the magician SCOTTO or the English scholar Dr. JOHN DEE. Precisely, the foundation of the Sapiens Donabatur Astris (S.D.A.) is due to the need to initiate secret studies around documents brought by Dr. John Dee on his trip to Prague in 1584, when he showed Rudolph II the famous "talking stone of Princess Papan".

It is a strange story, typical of that absurd century of Renaissance geniuses and great inventors, but also of selfish kings, religious wars, and a gold faith that destroyed America, piously disguised as an "effort" of Christian civilization to "save" savage and pagan peoples.



## THE STONE MIRROR OF PRINCESS PAPAN

It is well known that when Hernán Cortés took possession of TENOCHTITLÁN (MEXICO) in 1520, he learned that the sister of the Aztec emperor MOCTE-ZUMA, Princess Papan, had prophesied the arrival of white and bearded warriors, a description that perfectly fit the Spanish conquistadors.

In America, the ruling castes, descendants of Atlantean survivors, were of a purer hyperborean lineage than the degraded Europeans. That is why they kept alive the "memory" of the White Gods and of Christ-Lucifer, whom they called Quetzalcoatl, which means: feathered, winged or flying serpent. This "memory of blood", common to all the white races, was, however, fatal for the Aztecs because they did not know how to evaluate IN TIME the strategic confusion that the conquerors suffered. The degree of "confusion" of a virya is measured by his "tendency to pasu", a question that requires, for its understanding, the definition of



the corresponding psychological types. This we shall do later; but for now, as an example, let us consider that "that surprising greed for gold" which transformed the conquerors into greedy and selfish beasts, is a typical tendency of the pasu. For the pasu is rational and cunning, as opposed to the virya who is intuitive and spontaneous. The pasu, animal-man, "evolves" or "devolves" within the material order; and his "tendencies" can be accurately described as SATANIC. The Aztecs, even though they possessed a certain racial purity that placed them strategically above the Europeans, were unable to distinguish and evaluate the tendencies of the pasu and the danger they implied. They were, as always in these cases, dazzled by a boast of "superior" culture and civilization in the domain of matter. But this "superiority" represented by the technology to build weapons, warships and all sorts of material objects, which seems so evident before the lack of means of a "savage and pagan" people who believe in a Serpent God coming from Venus, is completely illusory from a spiritual point of view and constitutes one more characteristic of the Kaly Yuga.

Hernán Cortés astutely took advantage of the prophecy of Princess Papan, who had foretold the coming arrival of the envoys of Quetzalcoatl, to pass himself off as the "son of the Sun"; and in an unprecedented military campaign - 400 Spaniards against 40,000 Aztecs - seize Mexico. The AH KINES priests, of the solar cult, had also foreseen the imminent arrival of the foreigners who would fulfill the ancient prophecy made by Quetzalcoatl before leaving. How could the Aztecs have made such a mistake, a mistake that cost them their empire and the definitive collapse of the civilization of Anahuac?

First of all, let us remember that it was "the last Quetzalcoatl", the one who came to America in the tenth century, who left a prophecy that the Toltecs would not forget for five hundred years: "He announced to them that white, bearded men would come from the East and subdue all peoples, destroying their religion and their race".

*This prophecy," says Camilo Crivelli, "made by a man who distinguished himself from the Indians by his knowledge and virtue, by his dress and even by his white complexion, was so deeply engraved in the spirits that it was transmitted by the people from generation to generation. When the Europeans landed in America, the prophecy of Kukulcan served them more for the conquest than their swords, and Moctezuma himself, king and superstitious pontiff, believed that to resist the conquerors was to oppose the conquistadors, and that to resist them was to oppose the conquistadors.*

*the gods".<sup>1</sup>*

This is one reason, but fundamentally the fall of the Aztec empire must be attributed to the racial degradation of the reigning castes. Indeed, the Aztecs had already inherited from the Toltecs the memory of Quetzalcoatl; and the latter in turn took it from an older myth, original to the Maya, who must be considered as a remnant of Atlantean survivors.

Historians, based on a deficient archaeology, purged by the Catholic Church and other obscurantisms, usually speak of two stages in the history of the Maya people: the Old Empire (2nd century BC to 7th century AD) and the New Empire (7th to 16th century AD.) The Ancient Empire, whose classical period should be placed around the 3rd century A.D. when ironically in Europe the Roman Empire was collapsing, dominated certain patterns of the Hyperborean Wisdom, which can be easily discovered by analyzing Mayan culture and history. Because, apart from their surprising advances in lithic art, mathematics and astronomy, the Mayas developed the Hyperborean Strategy, that is, the social or collective science of the return to the origin. And the latter is the most important of the social or collective qualities. Indeed, every people or race that stands out in terms of the purity of its Hyperborean Tradition MUST MANIFEST THESE VIRTUES IN ITS STRATEGIC OBJECTIVES.

The Maya have shown to have very clear strategic objectives, since they practiced an "inward Imperialism", which coincides with the hyperborean techniques of "gaining the center by narrowing the circle". To understand this statement, one must look at the map of the Yucatan peninsula -currently Mexico, Guatemala and Belice- and consider that the Ancient Empire extended over a wide triangular area delimited approximately by the cities of Palenque, UAXACTUN and Copan. In reality, the triangle formed by the three sites mentioned is inscribed in a STRATEGIC CIRCLE, which included, towards the center, the cities of NARANJO, TIKAL, PIEDRAS NEGRAS, BENQUE VIEJO, etc., all later than the first three. This is enough to demonstrate the ADVANCEMENT TOWARDS THE CENTER, STRETCHING THE CIRCLE.

---

1 *CAMILO CRIVELLI - The Religion of the Ancient Mexicans.*

*P. 132, Article in "CRISTUS" - Ed. Angelus, Buenos Aires 1952.*

Of course, by DOMINATING the whole imperial area, and the center, the Ancient Empire concludes its STRATEGIC MISSION and disappears from History. But in adopting the Hyperborean Strategy to effect the leadership of a people, it is not always possible to proceed with as much clarity as the Maya have done. Most of the historical cases in which there was a trial of Hyperborean Strategy - Hyperborean Empire, Persia, Greece-Macedonia, Rome, Roman-Germanic Empire, Prussia, Paraguay, Germany, etc.-, show that sometimes it is necessary to "expand the circle" until gaining areas of conflict and then "restrict the circle towards the center". This expansion will inevitably provoke the reaction of the demonic forces which, unable to remain crouched during the strategic advance, will be forced to fight even against their will, bent in their own psychic strategy of infiltration by a more powerful strategy that will implacably unmask them.

The Toltecs received from the Mayas part of the ancient wisdom; but, as the centuries went by, the STRATEGIC CONFUSION became greater; and when in the 10th and 11th centuries several Viking expeditions -Norwegian and Danish-arrived, a MYTHICAL METAMORPHOSIS was produced in the mythological pantheon of Mesoamerica. The castes of the Toltec nobility merge with the newcomers "sons of the sun" and mistakenly identify the ancient Hyperborean Gods with the brave and intriguing, but also CONFUSED, Vikings. Thus, two or three Quetzalcoatl appear among the Aztecs, Toltecs and Mayas in the 16th century: one, very ancient, is the "memory" of the Atlantean Christ; another, an "ascetic" and cross-worshipping Quetzalcoatl, is nothing but a Catholic missionary; and a third, white and bearded Quetzalcoatl, is a true Viking. The latter is also the Kukulcan of the Yucatan whom Professor Jacques de Mahieu identifies as ULLMAN, a German navigator of the tenth century.

The result of such a fusion between Atlantean and Nordic lineages has been the most terrible strategic confusion, easily verifiable in the mythological fall that signified the cult of HUITZILOPOCHTLI practiced in Anahuac until the arrival of the Spaniards. This God is a primitive form of Jehovah-Satan, that is to say of the Demiurge, and under his bloody aspect of HUITZILOPOCHTLI, hummingbird magician, he demanded human sacrifices obliging his worshippers to maintain a permanent state of war - the XOCHIYAYAYOTL - to provide himself with victims. His insatiable thirst for human blood led the Aztecs to immolate 15,000 to 20,000 men per year.

This degeneration demonstrates that there is a direct relationship between the center  
of the  
Demiurge Jehovah-Satan, under any of his mythical aspects, and the PERVER-

SION OF THE HEROIC SENSE that war should have. On the other hand, the OPOCHTLI<sup>1</sup> HUITZILOPOCHTLI looks suspiciously like the "Gods" that the Druids have imposed among the Celts, all inspired by Jehovah-Satan like the Iranian BRAD, whose link in the Hebrew Jehovah is already proven<sup>2</sup>, or LUG, the Gallic God that the Germans called Loqui: "the dark one".

The cultural contact between Americans and Vikings produced a syncretism of Christian and Nordic elements with the Nahuatl myths. However, in spite of the fact that the Hyperborean Wisdom was buried under a tangle of CONFUSED SYMBOLS, the peoples of the Americas possessed a racially purer nobility than the Ju- daized families reigning in 16th century Europe. The "blood memory" of their Atlantean past was still alive in the American "Indians" and, although the dominion of Jehovah-Satan-Huitzilopochtli was ironclad, Quetzalcoatl was also remembered and INTENSELY WANTED HIS RETURN.

It is worth as an example of the deformed Aztec tradition and of their strategic confusion when dealing with the Spaniards, the speech that Moctezuma pronounced before Cortés, when he went to visit him in the palace of his father AXAIACA, that he had put at the disposal of his guests. *"... (I have) you for relatives; according to what my father told me, who also heard it from his father, our ancestors and kings, from whom I am descended, were not natives of this land, but upstarts, who came with a great lord, and who soon went to his nature; and that at the end of many years, he returned for them; but they did not want to go, because they had settled here and already had children and wives and a lot of command in the land. He became very dissatisfied with them, and told the party that he would send his sons to govern and maintain in peace and justice, and in the ancient laws and religion of their fathers. For this reason we have always hoped and believed that someday those from that part would come to rule and command, and I think that you are the ones, according to where you come from..."*<sup>3</sup>

When Hernán Cortés arrived in Mexico, as has been said, the Aztecs had some recent prophecies, among them that of Princess Papan, sister of Moctezuma. How had Princess Papan obtained news of the coming arrival of the conquistadors? By means of a polished stone that served her as a mirror and with the

---

1 OPOCHTLI = *Sinister, terrible or gloomy.*

2 See in this regard *"The White Goddess"* by ROBERT GRAVES.

3 JACQUES DE MAHIEU: *"The Great Voyage of the Sun God"*, p. 69. Ed. Hachette, Argentina. The speech of Moctezuma is taken from Lopez de Gomara,

which, according to an ancient Toltec tradition, one could "talk" with the Serpent God Quetzalcoatl. This stone, which is nothing more than an AT-LANTE TRANSDUCER<sup>1</sup>, was kept by Cortés until 1540, when he returned to Spain. At that time the stone passed into the hands of Pedro de Gante, a French missionary who arrived in Mexico in 1523, a relative of Charles V and Philip II.

A Spaniard born in Flanders, founder of the first school in Mexico at the Convent of San Francisco, the Franciscan missionary was a man of restless spirit and powerful influences. He showed interest in seeing the famous talking stone of the Papan Princess when he learned from Doña Malinche, the Mayan princess concubine of Cortés and official interpreter of the Mayan and Nahuatl languages, that it was in the possession of the Marquis of the Valley of Oaxaca<sup>2</sup>. It is a miracle that this happened; for Cortes, anxious to gain the influence he needed to overcome the numerous intrigues against him, hastened to send the speaking stone to Pedro de Gante. It is a miracle, we say, since in this way he was able to save it from falling into the hands of the Druids, Jesuits and Dominicans, who were waiting for the occasion to get their hands on it or destroy it. Pedro de Gante, on the other hand, carefully preserved it for years as a rarity, fascinated by the great polish of the stone, but without it revealing its secret. Because of this zeal, Cortes himself decided to leave it to him when he left for Spain, always in need of influence in the capital of the kingdom. The Flemish missionary, however, the attraction that the talking stone exerted on his spirit, soon abandoned his study due to the exhausting educational task that his mission had taken. The talking stone was deposited in a chest in the Convent of San Francisco, forgotten by all, when the illustrious priest died in 1572.

It would surely have been lost forever had it not been for an event that we would have to call fortuitous if we did not possess the certainty that an AUREA CATENA, a golden cord, links the Hyperborean viryas. For on a trip to Spain that Peter of Ghent made in 1567, while visiting his relative King Philip II, he met at court two young Habsburg princes of Austria, Ernest and Rudolph, sons of Emperor Maximilian II.

Of these princes, who were otherwise related to him, one of them, 15-year-old Rudolpho, seemed to the missionary so interested in the native peoples of America and their strange religion that he did not hesitate to refer to him the most exotic customs of the Aztecs, among them the unusual belief that a polished stone "allowed a

---

1 *The theory of lytic transducers is developed further below.*

2 *Title held by Hernán Cortés.*

the savages to speak with their Serpent God". This story greatly moved the future emperor of Germany, for when he learned that the aforementioned stone was in the possession of the missionary, he promised himself to obtain it for himself one day.

This inclination of Rudolph's should not be surprising, for in those years he tried to get hold of two relics belonging to his family, which are now kept in the Vienna Treasury: the AINBEHURN, tooth of the fabulous monoceros, 243 cm long by 6 cm in diameter; and the agate vessel brought from Constantinople by the Crusaders in 1204, 75 cm in diameter, perhaps the largest carved agate in the world, which he mistakenly believed to be the Graal or chalice used at the Last Supper.

Rudolph studied from the age of twelve at the Spanish court of his uncle King Philippe

He had been widowed for the second time in 1558 on the death of Mary Tudor "The Catholic", Queen of England and daughter of Henry VIII with Catherine of Aragon. During her short English reign - from 1553 to 1558 - Mary fought the schismatic heretics of the Anglican Church founded by her father and reinstated the Catholic religion, supported in this task by Spain which, under her husband Philip II, had become a bastion of the Counter-Reformation.

But when Mary died, Elizabeth I, daughter of Henry VIII with Anne Boleyn, ascended to the throne of England, supported by the Protestant party, beginning now the persecution of the Catholics and of some nobles who had supported Queen Mary Tudor. Many of these nobles took refuge in the court of Philip II, where they remained during the time that Elizabeth I's anger lasted, but those who sooner or later were allowed to return to England. What is interesting to note here is that the young Rudolph Habsburg lived with them during his stay at the Spanish court and established friendly ties that later allowed him to maintain contact with Elizabeth I, at a time when the war pitted England against Spain and there was no official contact with the House of Austria.

Rudolph II was crowned German emperor and king of Rome in 1576, a privileged situation that did not temper his inclination for the study of the occult arts, but rather affirmed in these tendencies, since he used his enormous power to get in touch with the wisest men of the time, as we have already said in the introduction. One of his first steps as emperor was to initiate an approach to his uncle Philip II of Spain to obtain the talking stone, an impossible task due to the many difficulties to be overcome: first, Philip II, a fanatical Catholic, was not at all enthusiastic about the idea of claiming from the Viceroy of Mexico an "object of pagan worship"; second, the missionary Pedro Gante had died in 1572, four years

**Rosario**

earlier, and among his belongings from America was not the famous "talking stone".



Third, an obstacle of which Rudolph II had no idea but which, to his dismay, he would soon become aware, was the Druids, always on the lookout to destroy the Hyperborean tradition.

The solution envisioned by Rudolph II consisted in obtaining from his uncle the safe conduit for a person he trusted to travel to Mexico to find the footwear. But this person should possess such authority that would allow him to overcome any obstacle, even if it was imposed by the ecclesiastical authorities. Convinced that in this way he would achieve his goals, he took action.

It took Rudolph II two years to get Philip II to accept his plan, and another year to get Pope Gregory XIII to authorize an envoy of the Emperor of Germany and King of Rome to "practice a general revision in the Convent of San Francisco in Mexico City, West Indies. Be that as it may, sparing unnecessary details for our story, what is certain is that in 1579 one of the nephews of Rudolph II, Frederick of Burgundy, 22 years old, left for Mexico, duly instructed on the object he was to seek and the prudence that the mission would require. The young Frederick of Burgundy quickly found the talking stone, forgotten for years in the chest of Peter of Gaunt, and was ready to return immediately to Prague.

Here the mysterious events that we mentioned as a third difficulty begin to occur: the Druids, infiltrated among the missionaries, soon learn that the talking stone was about to leave for Europe, and decide to prevent it. Thus it is that "some strangers" attack Frederick in his room the day before embarking, and flee leaving him for dead, after taking all his luggage. But, incredibly, he survives despite being almost strangled with a cassock string; and the most miraculous thing is that the thieves, who were undoubtedly looking for the talking stone, did not count on Federico having it on him, and did not search him.

And yet it had happened. The famous stone, placed inside a bag of fine peccary leather, was hidden in the clothes he was wearing when he was attacked. The result? Frederick was unable to return, but sent news to Rudolph II who, upon receiving it, began to suspect that his idea was not so good and to fear for his nephew's life.

After several weeks in bed, during which he did not part even for a second from the coveted stone, Frederick of Burgundy was again willing to travel and so it was that in the first days of January 1580 he embarked on the frigate

"CASTELLANA" in charge of relieving military personnel. This ship, after making After stopovers in Cuba and Venezuela, he departed for Spain.

But it was written that Frederick of Burgundy would never return to beautiful Prague, confirming what Rudolph II feared: a large-scale conspiracy had been set up to prevent the transport of the talking stone. Thus it happened that the frigate, after sailing from Cuba and heading for Venezuela, was attacked two days later by a fleet of English corsairs who "mysteriously" seemed to know the route the ship would take.

After a tenacious chase, with winds that strangely changed direction favoring the pirates, and after losing the mainmast, the frigate was finally boarded by two fast corvettes, and a bloody melee ensued on deck. Outnumbered, the brave Spaniards succumbed to an enemy that gave no quarter and fought with unheard of ferocity. No prisoners were taken; and only one Catalan sailor was able to save his life, who fell into the water and drifted for days clinging to a piece of mast until the tide deposited him on a Costa Rican beach. The captain ship, the one that first boarded, was the GOLDEN HIND, at the head of which was FRANCIS DRAKE, Elizabeth I's "favorite" pirate, who personally executed Federico de Borgoña by slashing his throat with his sword.

The corsairs knew exactly what they were looking for because, after finishing off all the crew members and carrying out an exhaustive search, which allowed them to find the bag with the talking stone in Frederick's corpse, they proceeded to set fire to the Castellana and flee. With this shipwreck, the adventure encouraged by Rudolph II came to a tragic end.

The German emperor, upon learning that the Castellana had disappeared without a trace, fell into a state of depression so acute that he was only able to overcome it precariously a few months later, but from which he never fully recovered.

However, the story of the talking stone did not end here for Rudolph II; it could be said that it had only just begun. For the Aztec stone, which Francis Drake's "informants" had assured him was extremely valuable, and which he hastened to send to Elizabeth I, was not to the queen's liking. But respecting the news that attributed great value, and intrigued by the unusual brightness that gave off one of its faces, she decided to consult on the Aztec stone to Dr. JOHN DEE, an expert in optics and one of the most important scholars of the kingdom.

As we shall see, this is another miracle that saved the stone mirror of Princess Papan; for John Dee was the best person in England to receive it, and into his hands the aurea catena led it. But England is a land of Druids; would the talking stone be safe, even in the hands of Dr. John Dee? More importantly, would it be possible to use it again, as the wretched Aztec princess did, to establish that much needed dialogue between man and the divine Hyperboreans? We will leave the answers pending, since they will become evident as the story unfolds.

While these events were taking place, one of the English friends of Emperor Rudolph II learned of the fate of the frigate and the assassination of Frederick of Burgundy. This friend, a young count, sent a letter to Rudolph II through Flanders, a country that the English supported in its attempt to gain independence from Spain. When the esoteric emperor learned of the fate of Frederick of Burgundy and the fate of the talking stone, his indignation and grief knew no bounds. But what to do? Philip II Habsburg was waging a war against England that was proving increasingly disastrous for Spain. And without the triumph of Spanish arms it would not even be possible to dream of recovering booty taken by the English from a Spanish ship.

There was only the remote possibility of initiating a secret negotiation. But this alternative was very dangerous, because of how badly Philip II could take it, in case he found out. And yet there was no other alternative for Rudolph II who, on the other hand, had already become aware of the strange things that happened every time he tried to get hold of the talking stone.

Thus began a secret negotiation between Rudolph II and Elizabeth I, which was to last four years, during which the emperor offered everything from gold to alchemist formulas or Dürer's paintings, and the astute queen was increasingly strengthened in the conviction that some arcane secret made the rustic black stone mirror so valuable.

Elizabeth I had no intention of parting with the stone and only negotiated in the hope of obtaining additional information from the impatient German emperor. But this information was soon not necessary; for Dr. John Dee solved the mystery posed by the talking stone and penetrated its mystery, claiming one day that through the "stone mirror" one could "see and speak with angels". This affirmation and the revelations he made later, meant the ruin of John Dee and, in a certain way, also that of Rudolph II.

## DR. JOHN DEE AND STONE TRANSDUCERS

Let's leave for a moment the stone mirror of Princess Papan and stop for a moment at our main character: who was John Dee? Undoubtedly a scholar of the time, but also more than that. Born in England in 1527, he studied at Cambridge, was the first translator of Euclid's "Elements" into English, a mathematician, a specialist in optics, in document encryption, etc.

He represented in the England of Elizabeth I, which was rising as the imperial power of the 16th century, one of those brilliantly multifaceted Renaissance spirits that in the Italian CINQUECENTO had with Leonardo its universal prototype. But whatever is said to praise the virtues of Dr. John Dee can add little to his main title: hyperborean. For John Dee was an AWAKENED VIRYA, mutated into an immortal Siddha after his "disappearance" in 1608. His incredible life, especially the period from 1563 to 1608, is an example of the dangers to which a hyperborean virya is exposed when he fearlessly, in order to fulfill a "strategic objective" in the cosmic war, reveals his superior condition and is exposed to the attacks of the Synarchy.

John Dee had been secretly working for 17 years on the reconstruction of the legendary "language of the birds", based on a work obtained in Antwerp, which we will relate later in the part entitled "The Steganography of Trithem, a Hyperborean work". From these investigations he had successfully mastered a primordial language that would make it possible to re-establish the dialogue with the "angels" - Hyperborean Siddhas - in the manner of the ancient oracles, for which he only needed a "magic stone" or "omphalos". John Dee knew that with the survivors of Atlantis (the "last" Atlantis, sunk 12,000 years ago and cited by Plato) a certain number of those stones that the Hyperborean Siddhas used in their "magical" operations on the concrete world had been saved. These stones made it possible later, when the Hyperborean Siddhas went to Agharta and the Siddhas of the Tenebrous Face ruled Atlantis, to communicate with them by serving as "oracles", the only application that was allowed to be given to the sacred stones. When the cataclysm, provoked by the Siddhas of the Tenebrous Face, came later, some magical stones were kept by the survivors.

But such magic stones were in reality TRANSDUCERS of psycho-physical energy built thanks to the advanced lithic technology that Atlantis possessed; it is

that is to say, they were MACHINES to interfere in the PSYCHOID COLLECTIVE UNCONSCIOUSNESS in both directions: obtaining information or influencing it to operate on the laws of nature. We will return to the functioning of the transducers when we study the Psychosocial Strategy of the SS; but for now we say that in order to "operate", these stone devices require the presence of a human being who establishes a "bond of sympathy" with them. This means, that certain magnitudes in the acting energies must be properly ADJUSTED to bring about the TRIPLE RESONANCE between the human being, the stone and the Earth (or the "telluric energies" of the place where the transducer stone is located).

In Atlantis, the human being operator of the stone was a virgin priestess, a condition that was imposed on certain biological restrictions to achieve perfect harmony in the psychophysical force fields of the human body and, of course, this choice of virgin maidens had nothing to do with moral premises of any kind.

The fact turned into tradition by the survivors who had "forgotten" the sense of it, led them to form the castes of virgin priestesses so common among the Incas, Aztecs, Trojans, Greeks, Romans, Hindustani, Egyptians, etc. The survivors of the purest hyperborean lineage, that is, those who took refuge in northern Europe, called them "virgins of Fasta", as the Frisian manuscript OERA LINDA tells us; and in a less pure tradition, the Romans, for example, transformed them into "virgins of Vesta". But they were also called, after the catastrophe, "Virgins of the Sun", Priestesses of Mithras, Daughters of Agni, etc.

In spite of this insistence - on the part of profane survivors or those who had lost the knowledge of their ancestors - for the feminine figure as priestess, or pythoness custodian of the oracle, the reality is that there is no physical law that allows the male sex to operate with the stone transducers. There are, it is true, biological restrictions that must be overcome when tuning a transducer stone; and these difficulties are aggravated if the officiant is male; but it is not impossible, or even difficult, to operate the stones if the man is properly prepared. The Druids were well acquainted with these traditions, for during their displays of amazing power over the forces of nature, they made use of a stone transducer known as the "snake egg," the Germanic name for the fact that, just as in the snake egg the evolution of the reptile can be observed through the thin membrane which is the "shell," so also when looking at the stone a strange MOVEMENT IS NOTICED WITHIN. Such "movement" is none other than the visible effect of the phenomenon of energy transduction described by some as a "vaporous luminescence" and "vaporous luminescence" by others.

by others as "shiny snakes"; that is, in the first case, a kind of "car-  
The first one, "static ion generation" and the second one, simple "arcs" of telluric energy.

The Roman scholar Pliny the Elder, in his HISTORIA NATURALIS, describes one such transducer: *"The egg is called ANGUINUM. The Druids say that hissing serpents pass up here into the air, and that it must be caught with a cloth and never allowed to touch the ground; and he must instantly flee on horseback, for the serpents will pursue him until some current stops them. This should be checked, they say, by seeing if it (the stone) floats on the current of a river"*.

To this comment of Pliny's Robert Scrutton replies as follows: *"Although this superficial ruse was sufficient to mislead Pliny, it can easily be seen that it was a genuine description of the DISCHARGE of a transducer. The wily Druids must have understood that Pliny would understand nothing; and so they told him the truth. Whistling serpents or telluric currents, by charging the object, make it float in the air. There are numerous references to the levitation of such transducers. Now, since the transducer held a static charge on its surface, if it was grasped with bare hands it would probably produce a painful discharge in the person grasping it. Discharge would also occur if it were allowed to touch the ground; hence the need to hold it in a non-conductive material, such as a woolen cloth. Nor could such a transducer cross the flowing waters of a river, whether it flowed underground or above the surface. It would remain quivering in the air, like the muscles of a dowser's wrists, due to the telluric currents thrown up by the current. It would float because it was hollow, but it would stay fixed in one spot by telluric energy, like an iron particle in a magnetic field."*

Pliny's account continues, *"But as it is the custom of the magicians to conceal their frauds with a cunning veil, they pretended that these eggs could only be taken (charged) on a certain day of the moon, as if it were incumbent on mankind to make the moon and the serpents agree on the time of the appearance."*

*"Here it becomes even more obvious that Pliny was taking it all literally. He was not able to understand how men could make snakes lay their eggs in a particular lunar phase. In reality, the snakes were telluric energy, which (...) varies with the phases of the moon."*

Pliny goes on to say: *"I have seen one of those eggs; it was round; the sheath was cartilaginous and like the arms of a polyp. It was highly esteemed by the Druids. It was said to ensure success in legal matters and a favorable reception before princes: but this is false, for a VOCONTI man, who was also a Roman knight, had one of those eggs on his breast during a trial and was condemned to death by the Emperor Claudius."*

*"Unsurprisingly, the transducer did not "work" for the Roman gentleman; it would not be tuned to his biorhythms and therefore could not help him improve his reasoning and eloquence faculties. He probably stole it from a Druid."<sup>1</sup>*

The Druids commonly used the stone transducers in their "magical" practices and were very careful to prevent anyone else from possessing them. Thus, resorting to any procedure, from deception, intrigue or spells, to the uprising of revolted peoples, they "recovered" the magical stones that the Atlantean survivors had kept. The fall of Atlantis was produced mainly, as Plato tells in the Critias, "by the racial sin of the mixture of bloods", that is to say by the "blood confusion" and loss of the Minne. The survivors, in different degrees of confusion, remain isolated among themselves, separated by thousands of kilometers, "forgotten" of their Atlantean origin and of their cosmic hyperborean ancestors. They form small tribes or groups that will later give rise to many of the peoples that have come down to us today. The most sophisticated are those who have managed to save a "virgin priestess" or a "mother", with their sacred stone they found various cults and oracles preserving, more and more degraded in the oral tradition, some remains of the ancient wisdom. Against them will be directed the attack of the Sinarchy from its hidden center CHANG SHAMBALÁ to "rescue" the speaking stones and not a few of the bloodiest wars recorded in history have been made with the hidden purpose of destroying the oracles and stealing the sacred stone.

It was Druids who led the Celtic expedition of Brene, in 390 B.C., to the Greek temple of Delphi to steal the OMPHALOS, the stone that marked the "center of the world" and allowed the Pythia to communicate with Apollo and the Hyperboreans. And it was Celts, led by Druids, who plundered the simple Etruscan temples and stole their sacred stones. The same thing happened to the Iberians and Ligurians (with the exception perhaps of the Iberian "stone lamp" that Belicena Villca mentioned in his letter, but this remains to be confirmed, neffe Arturo) and by infinite intrigues, the Iberians and Ligurians were able to steal the sacred stones of the Etruscans.

---

1 ROBERT SCRUTTON: *"Secrets of the Lost Atlantis"*, p.

The Visigothic kings who had the misfortune to rule over Druid-infested Celtic peoples also lost theirs.

The complete list of the bloodthirsty persecutions undertaken by the Druids would be almost infinite and impossible to transcribe here, but it is appropriate to raise some questions about certain significant facts: Was it not the Celts who conquered America and destroyed its civilizations governed by castes of Atlantean hyperborean lineage? And were they not incited to do so by Catholic priests, in truth infiltrated Druids, who justified the most dreadful crimes under myths such as the supposed "paganism" of the "natives" and the need to "civilize" and "evangelize" such "savages"? And together with Celts and Druids, did not a large number of Jews travel to America in the first row, following the example of Christopher Columbus, whose Jewish affiliation today no one can seriously doubt? In the "discovery" and "civilization" of America there was a sinister synarchic conspiracy of which we will speak later, when dealing with the question of the Grail.

To conclude this part of the story, we must bear in mind that when Queen Elizabeth I gave the magic mirror to John Dee for his study, he was perfectly aware of its transduction properties.

*John Dee (Tower Ward, July 13, 1527 - Mortlake, late 1608 or early 1609) was a noted mathematician, astronomer, astrologer, occultist, navigator, imperialist and consultant to Queen Elizabeth I. He devoted much of his life to the study of alchemy, divination and hermetic philosophy. He devoted much of his life to the study of alchemy, divination and hermetic philosophy.*



## TRITHEIM'S STEGANOGRAPHY, A HYPERBOREAN WORK

We have already mentioned Queen Mary Catholic of England, wife of Philip II of Spain. During her reign, Dr. John Dee was imprisoned for conspiring with the Protestant party. He was released from prison in 1558 by Queen Isabella I, who later entrusted him with several diplomatic missions on the continent, an occasion that the scholar took advantage of to search for manuscripts of alchemy, of which he was an enthusiastic enthusiast.

In 1563 he was on a secret mission in the Spanish Netherlands, in connection with the independence movement that England was encouraging there, when he learned that an old Jew possessed certain very valuable manuscripts which he would part with for a large sum of money.

He was a Portuguese Jew named ISAAK LAKEDEM who had arrived with his entire family in Flanders after the mass expulsion decreed in 1497 by King Manuel I, the Fortunate. Most of his brothers of race, and even his own family, continued their journey to Amsterdam, a city that would soon be known as THE NEW JERUSALEM; but Isaak remained for many years in Brussels. This mercy was granted to him thanks to his status as a scholar-librarian, for by 1500, when his family left Lisbon, he was archivist of the TESOURARIA of King JOHN II. This profession - and the help of the many "converted" Jews who held high positions in the Flemish court of Philip the Fair - enabled him to obtain a position as royal librarian in Brussels, after "temporarily" becoming a MARRANO.

His zeal and obvious ability made him famous and highly regarded in Flanders, which is why he was allowed to stay for more than half a century. At the date John Dee arrived in Antwerp, Isaak LAKEDEM was over eighty years old, but still at the head of a royal library. He was now living in the ghetto, - in that Calvinist and Independence Flan- des of the 16th century it was no longer a major danger to be a Jew, so Isaak soon returned to his Levitical customs and garments - and had "discreetly" put up for sale certain manuscripts of "his property". John Dee understood the risk involved in such an acquisition, since such manuscripts were certain to be stolen from the royal archives; unless the Hebrew tried to swindle him with some forgery, a practice that was commonly used to be carried out with dupes or "apprentice alchemists". But John Dee was an expert and would not be easily fooled.

However, he was overcome with distrust when he found himself in front of the old rabbinical-looking librarian. He looked incredibly old, an impression accentuated by his shabby black frock coat and an old top hat from which two tired eyes and a bushy curly beard emerged. He said he needed the money to retire to live out his last years with his relatives in Holland, since all his earnings had so far been consumed by his passion for the study of the occult sciences. When he realized that his explanations only increased his interlocutor's doubts, he decided to be more explicit and said:

*- I see Sir that you are a very suspicious person. You do well because these times are very hard and you could be abused. But that is not my case. What I have told you is true; and if I agree to sell you so great a treasure as that which I offer you, it is because it is in my interests to make the transaction with a Briton.*

This allusion to his foreign status further affirmed John Dee's belief that the manuscripts were stolen. The old man, heedless of the effect of his words, continued to speak:

*- I will tell you a story, sir, which will perhaps dispel your doubts. Many years ago, more than forty years ago, a German scholar named HEINRICH CORNELIUS AGRIPPA VON NETTESHEIM was arrested and imprisoned in Brussels. A conspiracy had been hatched against him in 1531, for up to that time he had enjoyed the protection of the regent Margaret Habsburg, who had died in 1530 and was the daughter of the Last Knight, Emperor Maximilian I. Thus it was that in 1531, thanks to the multiple denunciations that Franciscans and Dominicans made to Charles V, but especially through the intervention of our traditionally strong rabbis in Holland, that Cornelius Agrippa was sent to prison. I played a miserable part in that conspiracy, which I do not regret, for my rabbi said that we were before the most terrible sorcerer, a declared enemy of true religion, who had to be mercilessly destroyed. When Agrippa fell I had the mission to requisition his numerous books and manuscripts to be confiscated in favor of the royal library, but secretly I received the order to burn everything. It was here that I committed the only sin that has tormented me ever since," the old Jew was now looking strangely bright-eyed. He continued speaking in this manner:*

*- I did not comply with the order; and not only did I keep those blasphemous writings, but I tried vainly to decipher them all these years. You must know, sir, that I am an expert cabalist, a disciple of Johanes Reuchlin, and that all my science has not been able to do anything against the mysterious writing in code of Agrippa's manuscripts. That is why I am selling it to you, because I need your money and because I trust that being you*

*a simple GOY you will not be able to decipher it. But I tell you this because I do not wish to deceive you.*

It seemed as if the old man was looking for some excuse not to part with the deeds. But John Dee considered that this attitude was a ruse of the cunning Jew to create a halo of mystery that would allow him to raise the price or bargain it down, as is customary among his race.

*- Tell me," said John Dee, "How is it possible that when Agrippa was released, there was no Agrippa claimed what belonged to him?"*

*- Oh," exclaimed the Jew in astonishment, "Heh, heh, heh. You don't understand, sir. Agrippa was treated with certain drugs in prison. Terrible drugs, which bend reason. That was done by your countrymen, sir, the Irish priests who came especially to interrogate Agrippa. When they left him, he was completely mad. And he was until he died in 1535. He should not have messed with THEM, Sir, No!*

John Dee realized that the Jew was raving, for with his eyes dilated with terror he continued to speak, no longer paying any attention to his interlocutor.

*- We are powerful but so are the FILI! Heh, Heh, Heh, Oh Yes, THEY are powerful and terribly ruthless. They tortured Agrippa's mind into madness using their DOOR OPENING DOOR OF THE SOUL drug....*

ISAAK LAKEDEM now looked pitiful. His eyes were wide open and a white foam was running down the corners of his mouth until it soaked his rabbinic beard. The wise Englishman stared at him in silence, with a passive expression. A few minutes later, having recovered, the old man sketched, without much conviction, an apology.

*- You must forgive me, sir. The secret kept all these years must have upset me and I have spoken without thinking what I was saying. -Well, are you willing to wear them or not? Answer me at this moment, for I feel that my health is getting worse, and I think that tomorrow I will take a trip to the house of my brothers who live in Amsterdam.*

John Dee, who believed nothing of what he had heard, feared that he was the victim of a hoax; for something he could not discern gave him the impression that the

The Jew didn't really want to sell. He dismissed fear as the motive, and furthermore, fear of whom? No one knew what he had to sell. And this absurd allusion to the FILI? John Dee knew, like any educated Englishman, a thousand stories about the Fili of Ireland, Scotland and Wales. And they all spoke well of the kindly Druids, Celtic wizards who guided them and helped them when the Saxons, the Angles, the Norwegians, the Swedes, the Danes, the Normans and the Romans tried to dis- trict them. What did the Jew's allusion mean? Surely he was delirious.

*- Well, Mr. Lakedem, we will see in a moment if we close a deal," said John Dee. But I must warn you that I possess all the works of Cornelius Agrippa, although I might be interested in an original manuscript of the GEHEINE PHILOSOPHIE. What I do not fully understand is your comment that such an important work was written in code. According to my reports Agrippa never wrote a book entirely in code. He did in 1517 a treatise on the Hebrew Kabbalah and how to decipher ciphers, but he himself did not use any system to write secretly, or ...?*

*- Heh, heh, heh, heh," the old Hebrew's laughter sounded like a cock cluck. I see that you know the subject of which I spoke at the beginning. Yes, sir; you are right in supposing that the sage of Cologne did not write in code. But the work I offer you is not by Agrippa, but by a sorcerer a thousand times more powerful than Cornelius Agrippa. It is the eight manuscript books of Abbé Tritheim, containing the most terrible set of secrets ever written since the angel Raziel gave his book to Adam. May Raziel and Michael plunge Tritheim into the GEHENA!*

ISAAK LAKEDEM had finally said something that aroused John Dee's interest. Like all alchemists of his time, he was aware of the famous work of Abbé Tritheim, which had been believed lost since 1516. The story told by the Jew was now becoming convincing; and John Dee thought it was worth the risk of buying a forgery even if there was only a one in a thousand chance that the work was authentic.

After haggling for a few minutes, the deal was closed: ten pounds of gold for a trunk of manuscripts. Soon the wise Englishman would understand that he had made an extremely advantageous transaction; for the acquisition, if it were possible to appraise it for its spiritual value, was surely worth thousands of times the price paid.

Agrippa's trunk contained manuscripts of most of his works, although many were not by his own hand but by skilled copyists, among them the book that in 1517 he dedicated to the regent Margaret, his protector, in which he exalted the most important of his works.

tion of feminine beauty. There were also texts by other authors on alchemy, astrology and hermetic science. But the mystery was undoubtedly the fine leather package containing the eight handwritten volumes of TRITHEIM'S STOEGRANOGRAPHY and a letter from him addressed to Agrippa.

Jean de Heindemberg, known by his pseudonym TRITHEIM, was born in 1462 in the village of TRITTENHEIM, Rhineland Palatinate. During his youth he belonged to a secret society called SODALITAS CELTICA (Celtic brotherhood) to which belonged some Rhenish occultists of Celtic origin as CONRADO MEISSEL, nicknamed CELTES PROTUCTUS ("the first of the Celts", a title that clearly reveals his Druidic affiliation). There were also pure Germans like a certain Rodolfo Huesmann "Agricola" or John of Dalberg "John Camerarius"; famous teachers like Jacques Wimpfeling and even a "renegade" Jew, Paul Ricci, who taught the Kabbalah to the members of the society.

If Tritheim warned of the danger to which an enlightened hyperborean spirit, such as his, was exposed in a CELTIC SODALITE infected by Jews and Druids, it is something that we must doubt since his imprudences led him later to ruin. In any case, Tritheim entered the Order of St. Benedict at the age of 20. This order alone deserves a separate study, so we leave this task for another occasion, and consider now that in the monastery of St. Martin in APANHEIM, at the age of 23, Tritheim will be appointed Abbot. There he begins his famous - and tragic - task of forming the most complete manuscript library in Germany. He also wrote a great deal; but his most important work for our story is naturally the Steganography.

In 1499, due to a letter that Tritheim foolishly sent to the Carmelite priest ARNOULD BOSTIUS and that reached its destination when the latter had died, the existence of Steganography was made public. In the letter, a copy of which Tritheim himself published years later in his book POLYGRAPHY, the portents that could be achieved if the eight volumes were studied and the rules followed were described: Mastery of any language on earth immediately; mastery of cryptography in any language, so perfectly that no one who was not in on the secret could decipher; mastery of techniques for telepathically directing peoples; mastery of communication techniques, at any distance, by means of certain LYTICAL APPARATUS; mastery of techniques to foresee future events; mastery of Alchemy and the possibility of collectively taking advantage of TRANSMUTATIONS; mastery of life, possibility of creating the HOMUNCULE; mastery of the whole science of Steganography by means of an infallible AUTOINYCATIC technique (according to Tritheim), etc., etc.

One can imagine what happened when the contents of the Steganography became known: a sinister conspiracy that began with the rebellion of the Benedictine monks, who belonged to his convent in SPANHEIM, and culminated in the papal prohibition to publish the Steganography on pain of excommunication. In 1505 he had to renounce Spanheim and his library, and in 1506 he submissively left for the monastery of St. James in WURZBURG.

From where or from whom did Tritheim obtain the formidable knowledge that he poured into Steganography?

He tells it in the Polygraphia, a book he wrote in Wurzburg between 1506 and 1508: "angels" reveal to him "THE WAY TO OBTAIN KNOWLEDGE FOR ITSELF".

It is clear to us. Tritheim, awakened virya, is trained by the Hyperborean Siddhas on how to READ the books of the Nine Unknowns. Of those nine books, perhaps for the first time in many centuries, Tritheim summarized and copied the science of eight of them in his Steganography.

We know of the existence of the Society of the Nine Unknown Ones mainly from the account given of his contact with it by King ASOKA of India in 273 B.C.E. These Nine Unknown Ones were supposed to "guard" humanity's "good use" of intelligence. These Nine Unknown Ones would have the mission of "guarding" so that humanity would make "good use" of intelligence. In order to carry out their beneficent mission, these "holy guardians" have nine books, each one with its own, which would have the unusual property of not being FINISHED, but that permanently ONLY new wisdom is WRITTEN in them.

Since ASOKA, much has been said, with terror and admiration, about this Secret Society in the countries and kingdoms of Asia, but only in the 19th century was its existence divulged in the West, especially through the work of the French ambassador LOUIS JACOLLIOT and the English policeman TALBOT MUNDY. However, in spite of the "unknown" character of its members, the Society of Nine has been acting in the West since the Middle Ages with interventions of different types and the "sending" of "adepts" to fulfill obscurantist missions. The famous "pope of the year one thousand", Sylvester II "the Druid", had been in their service, to cite one example among hundreds.

There is also a relationship between the Society of Nine and the affair of the "Rei- no del Preste Juan", which we will return to in another chapter. Finally, we should not forget that the power and impunity of this Secret Society of

"Unknowns

can obviously impress some weak spirits and in fact does so.  
in many cases, according to synarchic tactics.

We are not part of the legion of dupes who serve the Nine "Unknown" and if you consider that their lair is called Chang Shambala, surely they will already be more "known" to all. Because these Nine form the Superior Council of the most sinister organization of EXECUTION that the Synarchy possesses, whose "commanders" are known lately as MEN IN BLACK, or Men in Black (M.I.B. or H.D.N.).

Their magic books? They are stone (i.e., "solid state") transducers tuned to resonate with the so-called "records" or "memories" of the Earth, i.e., with the Collective Psychoid Unconscious of the living planet. They were stolen from Atlantis by the Siddhas of the Tenebrous Face as part of a greater booty -the heritage of all humanity- jealously guarded now by the M.I.B.'s. By means of such lithic instruments, books in a certain sense, one can obtain immense knowledge or penetrate into many terrible secrets, of which the most frightful is the one that reveals the origin of the hyperborean man or virya on Earth, his spiritual enchainment to matter and the deception, the Great Deception, to which he is subjected by making him believe that he has sinned in that primordial time when he inhabited a lost paradise. THE ONLY PARADISE, THE ONLY GOLDEN AGE THE VIRYAS HAVE KNOWN, IS CALLED THULE, AND IT HAS NOTHING TO DO WITH THE CREATOR OF THE SOLAR SYSTEM, NOR IS IT IN THIS MATERIAL UNIVERSE.

The original Thule is the Homeland of the Spirit and can only be PRESENTED with the conquest of the sanguine Minne. The Vril, only, allows to REMEMBER it; but this CENTER is the exclusive patrimony of the Siddhas; and to possess it, the virya must transmute himself into an immortal hyperborean. But, in any case, the most wonderful thing that the REMEMBRANCE of the primordial Thule implies is that whoever wishes to SEE it, and even to return to it, must CREATE it with the ABSOLUTE POSSIBILITY that the Siddha possesses. And this is the greatest mystery of the Vril.

Who prevents the viryas from returning, who has plunged them into matter, who has created the Great Deception, who has horribly slandered Christ-Lucifer and covered him with blasphemies? The Demiurge Jehovah-Satan. THAT IS WHY THE NINTH BOOK IS THE ONE THAT NO ONE OPENS: because it allows one to see the "face" of the Demiurge, "His Work" and "Himself", pantheistically diffused in the "creation". And, it is assured, no one who is incarnated could contemplate His Face and continue to live. And even in death there would be no peace for those who have descended into such infernal blackness of the spirit. Whoever opens the ninth book risks perpetual madness, a shriek, a shudder, a scream, and a scream.



of eternal terror, to a tragic, horrifying, unspeakable anguish, without consolation or relief.

But let us not fear for Tritheim: he did not open the ninth book. However, his "pe- cado" was great, for he had laid his gaze, that clean spiritual gaze of the Hyperboreans before which the sinarcas tremble with hatred, on the other books, reading in them a knowledge jealously hidden for thousands of years. And such audacity could not be forgiven. For the time being, it is taken out of circulation to Wurzburg; but that is not enough: it is necessary to destroy the Steganography and the copies of some parts of it that Tritheim allowed to be taken while he was in Spanheim. An enormous number of sinister characters, among them many members of the Benedictine order, the same to which Tritheim belongs, devoted themselves with great care to accomplish this task. The prior of Wurzburg is attacked from all angles, a negative strategic situation which, however, has the advantage of allowing the enemy to be identified. Consequently, it does not take him long to understand that the Order of St. Benedict is an order of Druids; and he realizes, late in life, many dangers that, in his youth, when he belonged to the SODALITAS CELTICA, he had not suspected.

But the wise Prior of Wurzburg is now a Hyperborean Siddha and is, therefore, incorporated into the Cosmic War; that is to say, he has understood the Hyperborean Strategy and is qualified to elaborate the tactics to counteract the synarchic offensive. The first thing in any strategy is to "fix the Objectives"; and that is why its main slogan was "to defend the Steganography from the restless bonfire and to foresee the way in which the knowledge contained in the work is perpetuated for its future use for the benefit of mankind". To accomplish these goals, he decided to call other Hyperborean viryas to his aid, using his knowledge of Hyperborean Mysticism to locate them - a subject that we will see developed in the study of the Psychosocial Strategy - seeking to produce in them the CHARISMATIC BONDING.

The first to come is the young Agrippa von Netterheim, 23 years old, a hyperborean virya eager to collaborate with Tritheim, possessing a truly superior intellectual preparation. It is the year 1510 and Tritheim senses that he has little time left to live. With this conviction, he decided to speed things up and commissioned Agrippa to write a work on Occult Philosophy, but not before training him in cryptography and supplying him with the "messages" that he should insert in it for other hyperborean viryas of the "aurea catena". This is the reality that John Dee ignored Agrippa's work, despite being himself an expert in cryptography, because he did not know the necessary keys for the decipherment of the text during the time when he read it and translated it into English.

In 1515 Tritheim decided that the virya best suited to bequeath him the Steganography was Agrippa, which constitutes a new imprudence; for the sage of Cologne, after his Occult Philosophy in whose prologue he praises Tritheim and publishes a letter of the latter, was equally in evidence before the Synarchy.

Perhaps a better choice would have been the young THEOPHRASTUS who since 1513 had been receiving instruction from the prior of Wurzburg. But Theophrastus, whose real name was PHILIPPUS AUREOLUS THEOPHRASTUS PARACELSUS VON HOHENHEIM, or sim.

PARACELSUS, who was only 20 years old in 1515 and, although he was a vir-awakened man as capable as Agrippa, did not seem to Tritheim that Steganography was in his hands. We already know the end of CORNELIUS AGRIPPA at the hands of the Druids, Jews and Catholics. That of Theophrastus Paracelsus was no better, for many years after these events that we are narrating, in 1541, being very famous as a physician and alchemist, he died murdered in Salzburg by "unknown persons" who carefully searched his belongings.

Theophrastus Paracelsus was executed by agents of the Synarchy in 1541; and one wonders whether Tritheim might not have foreseen his sad end by using his many esoteric resources. If so, then the choice of Agrippa as the repository of Steganography must be considered correct, and Tritheim's "imprudence" would not be anything more than a very clever hyperborean tactic. We believe that Tritheim has found a way to "divert" the attention of the Synarchy towards Theophrastus Paracelsus, allowing, in a mysterious way, Steganography to "reach" John Dee. The story of Theophrastus is very long and interesting, but we cannot dwell on it more than necessary. Let us only recall that after Tritheim's death, in 1516, a tenacious persecution was unleashed against Theophrastus, which often deprived him of his professorships and led to the prohibition of his books, but which, nevertheless, was never based on a formal accusation that culminated in the stake. His enemies had no choice but to murder him without having found what they supposed was in his possession.

Be that as it may, what is certain is that the wise prior of Wurzburg made a move that would ultimately save Steganography: he made a secret copy, to be sent to Agrippa, and gave the original manuscript to the Elector of the Palatinate, Philip, to keep it "until the Holy See issued a final decision on the work. A few years later this work was burned by Count Frederick II of the Palatinate, Philip's son, at the request of the Dominican bishop, thus closing the official chapter of the history of Steganography, considered definitively lost after that holy incineration.

In Agrippa's trunk, acquired by Dr. John Dee, was the secret copy of the Steganography and a letter from Tritheim where, after narrating part of the misfortunes exposed here, he begged the wise man of Cologne to keep the manuscripts in the greatest secrecy while the "Superiors" sent whoever deserved to have them. He also forbade Agrippa, reminding him of a certain oath taken at Wurzburg, to make further copies of the writing. These instructions were happily respected by Agrippa and, if we think that for his own work Occult Philosophy he was persecuted, imprisoned and finally reduced to madness, we can wonder what his enemies would have done if they had known that he possessed a copy of the Steganography. But things would have turned out differently: the aurea catena had charismatically linked the English virya to Tritheim's work, and his reading would enable him to rise to the highest peaks of the Hyperborean Wisdom. And these two great men, Tritheim and John Dee, separated by a few years in history, lay the foundations of the spiritual movement that five hundred years later will provoke a NEW LEAP in humanity. A MUTANT LEAP that takes place every seven hundred years - the previous one was the one promoted in the 13th century by Frederick II Hohenstauffen and the Cathars of the French Languedoc - but this time it will be definitive and will put an end to the Kaly Yuga. For then the peoples of the Earth will have the immense joy of having the Führer of the Germans, an immortal Siddha who will wage the Total War against the Sinarchy, after which will come the HYPERBorean MILLENNIUM and the PARUSIA OF CHRIST-LU-CIFER. The Führer will again open the eyes of the virya so that he may find the path of return and walk it with weapons in hand, fighting face to face against the vile enemy Jehovah-Satan.



*Cycles of life and death during the Kaly Yuga, the Age of Darkness.*

## ELEMENTARY NOTIONS ON HYPERBOREAN WISDOM

### I.

It is possible that upon becoming acquainted with the significant details of the lives of the viryas involved in the secret history of the Thulegesellschaft, as we have presented them so far, going back to the sixteenth century and even further back, it is NOT CLEARLY VISIBLE THE "LINK" THAT CONNECTS THEM. In other words, how do they manage to

Does this happen because the viryas possess a common element? Is this common element something cultural, such as esoteric knowledge? It is a fact that all the viryas were esoteric: does it not indicate that they shared a Secret Doctrine and that a master-disciple relationship, related to such Secret Doctrine, would be the link sought? All this REASONING is an error; and as it is a dangerous error, we will try to dispel it before proceeding further with the story of John Dee and the mirror of Princess Papan.

There is a generalized attitude which consists in seeking, by means of the rationalistic resource of COMPARING the work and thought of the viryas, a supposed Secret Doctrine of which ALL should have participated. The results of such UNIFYING attempts cannot be more absurd, especially because they FORCE the facts with the purpose of JUSTIFYING dogmatic conclusions postulated a priori, that is to say, preconceived.

But the truth is that there IS NO such "Secret Doctrine" or "esotericism" common to viryas, because they are all individually "esoteric". This statement may seem to be a paradox, but we shall see that it is not so.

Notwithstanding the difficulties presented by its interpretation, the problem is real and can be formally posed for elucidation as follows: What is the LINK linking the viryas involved in the secret history of the Thulegesellschaft? Is it an esoteric Secret Doctrine whose knowledge turns the viryas into COFRADES of a Secret Society, as it happens in the organizations of the Synarchy?

A first answer can be found in our previous dissertation, when we compared the Thulegesellschaft with the Secret Societies of the Synarchy and spoke of the CLOSED CIRCLES. Taking into account that teaching can

to consider that the viryas (Trithem, Agrippa, Theophrastus, John Dee, etc.) formed a CLOSED CIRCLE whose CHARISMATIC CENTER was a Hyperborean Divine. This answer is CORRECT but insufficient because, for example, it does not provide INDICATIONS to overcome the above-mentioned paradox: the viryas are "esoteric" but -we affirmed- there is NO "common esotericism" that serves as a nexus between them. But since only the rationalistic observation of "comparative analysis" is responsible for this apparent paradox, we will expand this answer by drawing on some concepts of the Hyperborean Wisdom. To begin with, let us consider that from the fact that "all viryas are esoteric", the rationalist mentality tries to extract an inflexible law: the "common esotericism". And the truth is that "the fact that all viryas are esoteric" DOES NOT IMPLY THAT THAT MUST BE THE LINK THAT UNITS THEM; but to accept this conclusion without reflection may lead us to seek ANOTHER EXPLANATION FOR THE FACT OF THE LINK. Which would be another mistake, since the most correct attitude is not to look for ANY EXPLANATION.

For only the AUREA CATENA can be distinguished as a linking factor between the viryas, but it is ABSOLUTELY TRASCENDENT and cannot be represented: IT CAN ONLY BE INTUED. Apart from this, it is useless to try to establish similarities. There is no common philosophy or Secret Doctrine; nor do they belong to a Secret Society; nor do they often know that others SEEK THE SAME THINGS as they do, much less HOW MANY THEY ARE. However, they all synchronistically coincide in the ETERNAL RETURN and that is why they find themselves in certain historical circumstances.

There is a common hyperborean sense in the events of the viryas of our history, but this sense, this intention, this tendency to mutation, IS NOT A LOGICAL CATEGORY BUT A STRATEGIC CATEGORY. It cannot be apprehended with reason because it is not rational; but neither is it irrational. There is here another paradox, which is JUST AND NECESSARY, we shall see why.

A strategy is a MEANS, or the planning of means, to obtain an END. In war, strategy is the total set of measures that must be put in place to achieve success, that is, "to impose our will on the enemy". For the Hyperborean viryas it is CLEAR AND PATENT that there is a cosmic war and that we are all engaged in it. The BLOOD CONFUSION that the lost viryas suffer is also an ACTION OF WAR, a SATANIC TACTICAL ACTION, to impede the AWAKENING, the RETURN TO THE ORIGIN and the LIBERATION FROM THE GREAT ENGAGEMENT. That is why we say that EVERY ACTION OF THE HYPERBORN VIRYES IS A CATE-  
STRATEGIC GORIA and that, as long as there is no clear vision of the strategies in play, it is not possible to INTERPRET such actions.

When a people is collectively identified with a philosophy or religion, going so far as to regulate daily life according to norms, precepts or laws emanating from such philosophy or religion, we say that these constitute a "way of life" for those who practice them. Thus, we say "Buddhism is a way of life", or "they govern their life by the Decalogue of Moses", or "the Neoplatonists lived according to the Stoic philosophy", etc. In a similar way, STRATEGY MAY be considered THE WAY OF LIFE OF THE HYPERBorean VIRYA.

And if, when we see a mendicant monk of India meditating for long hours and performing all the Buddhist rites, we say "he lives every minute of his life according to his religion and she is always present in him"; we must also, analogously, say "the Hyperborean virya lives every minute of his life according to the Hyperborean Strategy, and she is always present in him showing him the path of return".

To make these statements clearer, let us briefly consider the hypothetical steps that a lost virya would follow to find the path of return. It will then become evident that such steps are nothing other than TACTICAL MOVEMENTS, i.e., strategic categories:

## **II.**

Initially the virya is LOST. Contributing to perpetuate this state is the Satanic Strategy whose main tactic is based on CONFUSION; on creating fusion or increasing the existing one. The following rule must be kept in mind here: FOR THE SYNARCHY "CULTURE" IS A STRATEGIC WEAPON.

The virya seeks ORIENTATION and for this he puts himself on ALERT. This is the first strategic category incorporated into ordinary life. The permanent state of ALERT will eventually lead him to doubt reality, its sensible appearance, and to distrust reason and the rational, which will be revealed as accomplices of the Great Deception. Under these conditions it is possible to AWAKEN, to become an AWAKENED VIRYA, by experiencing a NOSTALGIA for ANOTHER WORLD.

That primordial world which is sensed, and which attracts with the force of return, is the Homeland of the Spirit and its REMEMBRANCE IS CONTAINED IN THE BLOOD. He had been FORGOTTEN and this forgetfulness caused the loss of orientation, confusion, and transformed him into a LOST VIRYA. But by experiencing the Minne, the memory of blood, other eyes that never sleep will open, different from the physical eyes that only see the

illusion, and a PERMANENT STATE OF ALERT will be assumed, which is necessary in order not to yield to the enemy strategy and fall into a new and greater confusion.

If this should happen, the virya is already a STRATEGIC SUBJECT of whom it can be said: "all his movements aim at a single end"; "nothing can divert him from his route"; "his courage and fearlessness know no bounds"; in short, "he is an AWAKENED VIRYA".

The awakened virya will relentlessly go into combat against the ELEMENTALWES- SEN without EVALUATING THE PROBABLE OUTCOME OF HIS FIGHT, i.e. WITHOUT PROJECTING- IN TIME. He is only interested in the action itself, to the extent that it contributes to exalt his heroic or mystical virtue to such a degree that any return to ordinary life, to the Great Delusion, becomes unbearable. That human limit that can only be reached when the mind has been stripped of all dogma, of all morals, of all material desire, of all ties with the world; that primordial summit that can only be climbed to in the heat of combat; that spiritual height inaccessible to anyone who possesses a hint of evolutionary materiality, of duality, or of opposition to duality; that point of NO RETURN to which these sentences and many others allude is, with all precision, the product of PURE BLOOD.

But when we speak of BLOOD IMPURITY, this concept should never be confused with that of RACIAL IMPURITY, in the sense of race mixing, miscegenation or bastardization. It is true that ethnic miscegenation causes a GENETIC CONFUSION and that this increases the STRATEGIC CONFUSION of the virya; but it is only a part of the problem and, we would say, the minor one. BLOOD IMPURITY is an esoteric concept of the Hyperborean Wisdom that refers to the GONASTIC CONTENT of the blood and, of course, to OTHER BLOOD, different from mere lymphatic plasma or hemoglobin. We must bear in mind, then, that RACIAL PURITY is a favorable factor, but that this by itself assures nothing as to BLOOD PURITY. And it is of no use, for example, to have a racially pure people like the CELTIC, if they are totally dominated by the Synarchic Strategy.

Therefore, when the awakened virya decides to go into combat to PURIFY HIS HEALTH, this attitude alone makes him independent of his degree of ethnic and genetic crossbreeding.

Different is the case of the collective mutation, where the racial factor is important; because a BLOOD COMMUNITY can be guided CHARISMATICALLY by a

leader or führer. This case is dealt with extensively in the MANUAL OF PSYCHOSOCIAL STRATEGY OF THE SS (book 4).



The awakened viryas are charismatically linked to each other, due to their common origin, by a synchronistic bond that we call AUREA CATENA or GOLDEN CORD. It is a NON-PHYSICAL link, inapprehensible to reason, so we will momentarily desist from explaining it, although we will return to it later. For now we will only say that the awakened virya, the one who has FEELED the Minne and traces the AUREA CATENA towards the origin, INCIENTLY possesses a condition that PLACES him BEYOND any racial qualification or social pigeonholing. We do not say that this condition makes him SUPERIOR, but that it PLACES him OUTSIDE any standard of measurement. This condition is called HYPERBORROUS LINAGE and refers to a concept of SPIRIT RACE totally unknown to the common people because of the fierce concealment to which it has been subjected.

(To speak of a "race of the spirit" is to touch upon one of the most terrible mysteries, that of the arrival of the Hyperborean Siddhas in the Solar System and the cosmic TRAITION perpetrated by a part of them. We will come back to this story).

We said that the condition of possessing hyperborean lineage, the awakened viryas possess it INCIENTLY. What do we mean by incipient hyperborean lineage? Let us first look at a VULGAR interpretation of the phrase "incipient lineage", before answering according to the Hyperborean Wisdom:

The word "lineage" refers to the family ancestry, that is to say, to the ties of blood; and these are possessed or not, without alternative. On the other hand, "incipient" means "beginning"; so that if we say "Peter, of the Perez family, has an incipient lineage", we mean "Peter BEGINS to have Perez lineage"; which can only refer to some CHARACTERISTIC of the Perez that distinguishes them and that is clearly EMPHASIZED in the members of the lineage; that is, a HEREDITARY FAMILY PROFILE that BEGINS to manifest itself in Peter, or that Peter incipiently represents.

Therefore, to speak of a person's LINEAGE does not consist in alluding to the mere fact of belonging to this or that family; it implies a whole universe of races, qualities and styles that tend to form a well-defined family TYPO. In this regard, JAIME DE MAHIEU writes: *"The existence of such a TYPO cannot be denied in homogeneous lineages. The same current language admits it when it resorts to the expression 'air of family'. History knows lineages of artisans, peasants, industrialists, artists, statesmen, war chiefs, etc. THE LINEAGE IS, THEREFORE, A DIFFERENTIATED HEREDITARY BIOPSYCHIC SET"*.

It is puerile to emphasize these concepts which until a few centuries ago were only minimally known, but which the universal Bolshevization that began with the French Revolution has suppressed from "Western culture" ("For the Synarchy, 'culture' is a strategic weapon. ("For the Sinarchy, 'culture' is a strategic weapon.") However, it is still possible to observe that, in those non-massified domains of human activity, that is to say, where it is essential to have some CRAFT skill, the laws of lineage continue to be imposed. *In the human order,*" says Jaime de Mahieu, *"it is well known, although questioned by the deniers of the inheritance of acquired characters, that several generations are necessary to form a good worker in certain difficult trades, glassware, for example. We have more confidence in this respect in the testimony, and above all in the practice, of industrialists who affirm the reality of the phenomenon, than in the assertions of scientific theoreticians. Moreover,*

*Were not those transformationists of the last century contradicting themselves who, while denying the inheritance of habits, based their theory of the evolution of species on a gradual modification of the generations under the effect of the environment, a modification which could only be effected by the hereditary transmission of the progress made?"*

We now know that a lineage can be incipient IN AN INDIVIDUAL if it weakly presents the characteristics of the familial TYPO. It is a concept that includes the idea of DEVELOPMENT or EVOLUTION: there is a TYPO and a path of biological differentiation towards the TYPO. That is, a BEING and a BECOMING TO BE. Therefore, the REALIZATION OF THE FAMILY TREND is the best adaptation of a member to the figure of the "type", or to the metaphysical "archetype" that supports it and of which (the type) is its visible expression.

Let us now answer the question about the incipient hyperborean lineage that an awakened virya possesses, using concepts from the Hyperborean Wisdom. The hyperborean lineage does not recognize TYPOS. However, analogous to the case of the family lineage, there is a TENDENCY in the virya that drives him towards a REALIZATION. This TENDENCY emerges from the pure blood, from the Minne, and the REALIZATION towards which it points is obtained by an inverse path, marching backwards, seeking the hyperborean origin of the spirit. There is not here, as in the case of Pedro Perez, a becoming something determined, the conformation of a TYPO; on the contrary, in the inverse path, the DISSOLUTION OF ALL TYPO occurs, culminating the process in a sudden ONTOLOGICAL INDETERMINATION. Marching along the inverse path of return, one FINALLY reaches an UNCREATED state that can only be qualified as PURE POSSIBILITY. It is the REALIZATION OF THE Hyperborean TENDENCY (Minne) of the pure blood that is called spirit or Vril. This REALIZATION implies the definitive MUTATION of the awakened virya into immortal Siddha and its LIBERATION.

of the material order that governs creation. The spirit or Vril is INDESCRIBIBLE and it is prudent to refer to it as PURE POSSIBILITY. However, the only concept of EXISTENCE possessed by the Hyperborean Wisdom corresponds to the Vril. That is to say that nothing spiritual has existence outside the Vril, and that all intermediate psychic states must be regarded as illusory. Nothing exists outside the Vril because to obtain the Vril is to BE OUT OF EVERYTHING. And "ALL" is the Universe of The One, the Demiurge author of matter whose ALL-pervading substance and whose will SUPPORTS the things of the concrete world.

For these reasons, for the Hyperborean Wisdom the PASU does not exist, for his SOUL is a projection of the hypostatic monad that the Demiurge THOUGHT and EMANATED. Evolution provides only an illusory development of the ego or "I" that can never overpass its own archetype or the ultimate monad. The soul of the pasu may appear as "highly evolved" and even "great" or "very holy", but it is pure illusion; its "existence" is subject to the Great Cosmic Cycles and has fatal dissolution in the PRALAYA or MAHAPRALAYA. At the culmination of one of these Great Cycles of evolutionary manifestation of matter or MANVANTARA, the FAGOCITATION of everything "created" is produced by the Great Deceiver and means the end of all the Masters, Gurus, Choans, Rishis, etc.

Every virya must always keep in mind the following strategic rule: "THERE IS NO POSSIBLE ALTERNATIVE EXISTENCE OUTSIDE THE CONQUEST OF THE VRIL". That is to say, there is NO OTHER alternative to exist other than mutation.

### III.

On the other hand, there is what we call "Hyperborean Wisdom", that is, the Wisdom of the Siddhas, present in all ages of humanity. What a colossal mistake it would be to pretend that it constitutes a RATIONAL system of knowledge! And yet this is the most common attitude. Rationalism always tries to find simple relations; for this purpose it compares and looks for coincidences, analogies, similarities. If it finds them: it establishes laws; which should be, as far as possible, infallible. If there are not: then something like an abyss separates the instances. This attitude, suicidal from the intellectual point of view, can be summed up in two words: either reason or nihilism.

Even the subtlest spirits yield to the goddess of reason. Let us briefly review some of the ideas, as brilliant as they are fatuous, put forward by the rationalists in their obstinate attempt to UNIFY the principles that sustain the different sciences:

Those who study religions and COMPARE them, usually discover that something like a Primordial Tradition has left a common trace in the different myths (which, on the other hand, has always been affirmed by the most enlightened spirits of humanity, identifying this Primordial Tradition with the Hyperborean Wisdom). No sooner have they considered this than they ARBITRARILY conclude that this Primordial Tradition refers to a SINGLE COMMON MYTH. There is nothing more rationalistic and absurd than this hypothesis, which they naturally never succeed in proving, in spite of the interesting symbolic analogies they usually use in their theories.

This mental attitude is naive and childish, but, by dint of generalization, it is today "natural" or "scientific". Let us look at other examples.

If we speak of ethnology or anthropology, we are looking for a SINGLE RACE which, starting from a "center of diffusion", be it the East or the West, Palestine or the Gobi, etc., justifies with its displacements ALL known migrations. If we speak of religion, a SINGLE MYTH, located in a "center of diffusion", be it Atlantis or Lemuria, or Mu, or Hyperborea, or America, or Asia, or "the North", or "the pole", etc., must justify ALL religious cosmogonies and even "esotericism", which would be a quintessential part of the mythical synthesis.

The same happens if we talk about the origin of the Universe, where a UNIQUE, CENTRAL explosion is responsible for ALL that exists; or if we refer to Physics, where a law of the UNIFIED FIELD, which allows us to deduce ALL the laws of electromagnetism and gravitation, is still waiting for someone to invent it.

These REASONINGS, these UNIFYING ideas, are naive and childish, as we have already said. But, attention: here "childish" should be read "proper to the pasu", because the rationalism we are describing is the WAY OF THINKING of the pasu. And the tendency to unify is also characteristic of the children of Jehovah-Satan; let us not forget that the culmination of this tendency is the conception, also absurd and childish, of MONOTHEISM, a concept that conceals the pretension of UNIFYING in the figure of the Demiurge "The One" ALL religious devotions. Because the tendency to unify and monotheism are also WAR TACTICS of the Syarchic Strategy.

Even Max Müller, whose love for Jehovah is evident throughout his work, has remarked on the abuse that has been made of this "tendency to unification. In "THE SCIENCE OF RELIGION" he says: *"There has been much discussion as to whether mankind began with monotheism or polytheism. If you remember how they have been born and grown*

*the principal divinities of the Veda and how things have followed a natural, simple and inevitable course, you will perhaps think with me that the whole controversy is hardly worth anyone's dwelling upon, at least so far as the Indians or the Indo-Europeans are concerned. I believe that the question has never been proposed for its own sake, but that it is a legacy of that theory of the Middle Ages that religion has begun by a primitive revelation which, naturally, could only be a true and perfect religion and, consequently, a monotheism. Of course, this monotheism would have been preserved only among the Jews, the other nations having abandoned it to fall into polytheism and idolatry, from which they emerged later in a purer light, either by religion or by philosophy.*

*"In this respect," continues Max Müller, "it happens with religion what has happened with language. Without even having the authority of the Bible, or any other authority to invoke; without being able even to associate with their theory any clear and definite idea, a multitude of theorists in the Middle Ages, and even in our own day, have maintained that language, too, came out of a primitive revelation. This was the first step of the theory. Second step: this primitive language can be none other than Hebrew. You cannot imagine the erudition and ingenuity that was wasted in proving that Greek and Latin, French and English, were derived from Hebrew; but since, in spite of all the tortures to which Hebrew was subjected, the recognition of these degenerate children could not be wrested from it, from failure to failure, they were forced, in the end, to recognize that the process had to be recommenced with new data and that all the evidence that could be found on the origin and development of the human word had to be impartially gathered. This historical information on language produced a genealogical classification of the principal languages of the world, which at last gave Hebrew its rightful place beside the other Semitic dialects, and, as a result of this fact, the question of the origin of language took on an entirely new form."<sup>1</sup>*

In the previous articles (I and II) we have denounced that a widespread attempt to justify the CHARISMATIC NEXUS linking the viryas consists in imagining the existence of an alleged "common esotericism" or "Secret Doctrine". In this article III we have seen how rationalism elaborates theories on the basis of the UNITY of the principles on which the sciences are based. And now we must consider that, because of this "tendency to unify", when it is discovered that the viryas are "esoteric" and that this esotericism is related to a "Hyperborean Wisdom" of which they all speak, the rationalists cannot resist the temptation to suppose that there is a "common esotericism",

---

1        MAX MÜLLER: *The Science of Religion* - P. 243- Ed. Albatros, Buenos Aires, 1945.

free of charge, that such "Hyperborean Wisdom" constitutes the "common esotericism" or the "Secret Doctrine" sought. If this is so, it is reasoned, such Hyperborean Wisdom must be a "system of knowledge" or at least a "common myth" which, rationalized, gives rise to an "Esoteric Doctrine". This is a LOGICAL conclusion and therefore CANNOT BE TRUE.

We, on the contrary, affirm that the Hyperborean Wisdom is UNIQUE FOR EACH VIRYA in particular and, therefore, its teaching is different in all cases, there being nothing COMMON among the viryas. However, in spite of the absolute individuality of the knowledge acquired by each virya, certain TEMPORAL COINCIDENCIAS tend to occur, which lead to a synchronous contact between the viryas, when they have adopted a path that passes through collective mutation. The service in favor of the race causes the synchronic coincidence between the viryas, who star in stories like the one we are narrating, and in which it would be useless to try to discover a physical or cultural LINK outside the COMMON ORIGIN, which, as we have already said, is absolutely indeterminate.

In synthesis, the Hyperborean Wisdom, different for all, CANNOT BE TEACHED, but CAN BE LEARNED. This conclusion IS NOT LOGICAL BUT ABSURD and therefore MUST BE TRUE.

Let us make a final summary. We have raised the problem of the lack of a real LINK or LINK between the viryas of our History and the impossibility of considering the Hyperborean Wisdom as a rational SYSTEM of knowledge. The rationalist analysis will say that without such LINKS and without such a SYSTEM nothing can exist. We have in our favor the irrefutable fact that the story CAN BE TOLD and that the Hyperborean Wisdom can be LEARNED.

However, it is necessary to go deeper into this problem, and therefore, in Article IV we will approach it from another point of view.

#### **IV.**

This reiteration that we are making by going back several times on the same problem may surprise, no doubt, the rationalist mentality accustomed to moving linearly or "advancing vertically" in the conviction of finding, at the end of the road, a SINGLE solution, a definitive and immutable answer. But we do not share this LOGICAL optimism. We believe that there are many answers to the same question, and that even the simplest answer may be advanced.

The Hyperborean Wisdom can reach unsuspected depths if it is RE- THOUGHT, REPEATING the reflection, that is to say, the mental path that gave rise to it. That is why we have to ask and answer many times the same questions, so that through all the DIFFERENT answers that arise, the concepts of the Hyperborean Wisdom that govern our thinking can be glimpsed. So let us go around the circle again and ask again the initial question.

To possess hyperborean lineage, as we have already said, means, among other things, to be something unique; not repeated nor to be repeated, which constitutes a true SPIRITUAL INDIVIDUALITY (NOUS), TRANSCENDENT, opposed therefore to the illusory PSYCHIC INDIVIDUALITY, IMMANENT, of the pasu. Hence, to DISCOVER the memory of blood, to access the Minne, to consciously enter into the mystery of one's own hyperborean origin, always implies living a new adventure, never thought or imagined by anyone. The Hyperborean Wisdom is MUTANT and CHANGES unfailingly anyone who receives its gnosis. But this CHANGE, this MUTATION, is UNIQUE. So original is it, that is why the destiny of the awakened virya is called UNCREATED, as opposed to the "destiny" of the pasu, which is absolute MECHANICAL DETERMINATION.

In the light of these considerations, we can once again answer the fundamental question that we formulated in Article I. It is the question that arises in all rational minds when they try to find an "esoteric" link between different representatives of the Hyperborean Tradition: Is it possible, by the rational way of association or comparison, to establish a LINK linking the "GRANDS ESPRITS" of History, to find a LINK between their ideologies and doctrines, to find a RELATIONSHIP that reaches and ORGANICALLY LINKS the sacred symbols that express their different myths?

Let us first see how the same rational minds that usually ask this question answer it.

In the perplexity and bewilderment that follow the discovery that IT IS NOT POSSIBLE TO FIND AN ESOTERIC SYSTEM to justify the existence of so many men who LIVED ACCORDING TO SUCH A SYSTEM, the answer comes, to these BEAUX ESPRITS, by logical deduction: if it is not possible to RATIONALLY APPRECIATE the so-called Hyperborean Wisdom, which flourishes here and there, this must be attributed to two causes: either such Hyperborean Wisdom DOES NOT EXIST, or psychic manifestations of an IRRATIONAL character are so called. In the first case, if it does not exist, then its representatives are fakes, vulgar simulators. In the second case, if it is an irrational knowledge, our civilization calls those who possess it CRAZY, since only REASON differentiates man from animals and guarantees that they will not be able to be understood by the animals.

their NORMALITY. For a world made to the measure of the pasu, the answer given will be clear and categorical then: either phonies or madmen. There is no possible alternative and the theosophical-evolutionary system of the Synarchy and its infinite sects, shows the limit, miserable by the way, up to which they allow themselves to reach in their "spiritual-ritual" or "esoteric" inquiries. Outside of "theosophism" one is either a pretender, swindler, swindler, rogue, etc., or insane, schizophrenic, hysterical, psychotic, etc., but, in any case, firmly repressed by the satanic hosts.

The difficulties that the above questions present to the rational mind, and which appear whenever a SERIOUS study of the Hyperborean Wisdom is attempted, stem mostly from the refusal to accept that one is faced with a PARADOXICAL fact. Rationalist pride finds it difficult to accept that reality poses paradoxes, and even less is it prepared to face them. And yet, therein lies the key to rational defeat. It is not that "if no link, nexus, relation, connection, etc.," is found between different "facts performed by viryas who claim to be inspired by the Hyperborean Wisdom" the conclusion is: either such "Wisdom" does not exist or it is a mere irrational knowledge; and then: fakes or madmen. The fallacy lies in opposing the "rational" to the "irrational" to the exclusion of the paradoxes raised, for, precisely, the hyperborean condition of the virya makes him a "maker of paradoxes".

We will clarify this when we study the Hyperborean Cosmogony of the Thulegesells-chaft; but for now let us bear in mind that, by virtue of a DOUBLE OPPOSITION with the world of the Demiurge, every "hyperborean" - Siddha or awakened virya - GENERATES PARADOXES in any action he undertakes or thinks with respect to that world.

The Swiss psychiatrist C.G. Jung has made an interesting reflection that is worth remembering now as a complement to our previous criticism of "esoteric rationalism": ... *"Has it not been observed that all religious statements contain logical contradictions and statements that are impossible on principle, that even this is the essence of the religious statement? We have in this respect the profession of faith of Tertullian: ET MORTUUS EST DEI FILIUS, PRORSUS CREDIBILE EST, QUIA INEPTUM EST. ET SEPULTUS RESURREXIT; CERTUM EST, QUIA IMPOSSIBILE EST. (And the Son of God is dead, which is frankly incredible because it is absurd. And buried, he is risen again; this is true because it is impossible). If Christianity demands belief in such contradictions, it seems to me that it cannot reproach anyone for giving validity to a few more paradoxes. It is a strange thing, but paradox is one of the highest spiritual goods; clarity, on the other hand, is a sign of weakness. Therefore, a religion is impoverished interiorly.*



*when it loses or reduces its paradoxes, while it is enriched when they increase, for only paradox is capable of embracing, in an approximate way, the immensity of life. Clarity and lack of contradiction, on the other hand, have but one meaning; and are therefore inadequate to express the inconceivable."*

*"Not everyone," JUNG goes on to say, "possesses the intellectual capacity of a Tertullian who, evidently, was not only capable of enduring paradox, but even meant for him the ultimate religious certainty. The sheer number of the mindless makes the paradox dangerous. As long as it is a customary aspect of life and a natural thing that has never been questioned, it will continue to be safe. But if an insufficiently developed intellect (which, as is well known, always has the best opinion of itself) were to have the occurrence to make the paradox of a declaration of faith the object of its reflections, as serious as they are impotent, it would not be long before it would burst into an iconoclastic guffaw of derision and point the finger at all the uncovered INEPTITIA of the mystery. It has gone rapidly downhill since the French Enlightenment, for when this understanding, incapable of bearing any paradox, is awakened, there is no sermon to restrain it. A new mission then arises: namely, to bring this as yet undeveloped intelligence gradually to a higher step and to increase the number of those who can at least have a suspicion of the enormous breadth of a paradoxical truth".<sup>1</sup>*

So much for the position of the "esoteric rationalists" with respect to the question posed and our critique. We will now give a simple answer, elaborated on the basis of the synthesis of the concepts discussed in this chapter:

"Each quest on the path of the Hyperborean Wisdom is completely 'distinct'. There is no 'common esotericism' but infinite individual esotericisms, proper to each virya. Therefore, there is no 'link', 'nexus', 'relationship', etc. between the Hyperborean viryas that can be quantified."

This paradoxical answer should conclude this chapter. However, we will extend briefly to highlight another widespread error that is caused by not distinguishing that COMMUNITY OF LANGUAGE does not imply COMMUNITY OF IDEAS but COMMUNITY OF CONCEPTS. This is a "cultural", semantic error, due to the fact that rational analyses are carried out on the basis of CONCEPTS enclosed within

---

<sup>1</sup> CARL GUSTAV JUNG: *Psychology and Alchemy* - P. 35. Ed. Plaza y Janés, Barcelona, 1977.

linguistic constructions: WORDS, which try to represent IDEAS in order to facilitate communication among men; "COMMON" IDEAS which, naively, we believe have the same meaning for everyone.

Let us take a word; for example: "God". Everyone "knows" what it means, "knows" the CONCEPT; so much for reason. But is the IDEA "God," an IDEA that goes beyond reason, the same for all possessors of such a word? Or, in other words, does the word "God" evoke in all the same IDEA? Certainly not. And substituting the word "God" for any other word, we immediately understand that all words, apart from their conceptual content, that is, their conventional definition, exceed the rational, possess an IDEAL content specific to each person, non-transferable and inexpressible, which, probably, is related to what is called CHARACTER, STYLE, etc. of the individual and which differentiates him intellectually from others.

When this elementary distinction between the thing "in itself", the IDEA of the thing and the LINGUISTIC CONCEPT that the "name" of the thing represents, is not taken into account, it is possible to commit tremendous analytical errors. But if to the usual rationalist obsession of applying dialectical analysis to everything that exists, this error is added, then the result can border on the frontiers of foolishness. These frontiers are indeed reached in the case of "esoteric rationalism" because, being the viryas the possessors of a completely personal Hyperborean Wisdom, and having already committed an error by pretending to find a "common esotericism", a second error is committed by not understanding that the "esoteric" or "symbolic concepts" used by the viryas refer to ABSOLUTELY different ideas. As in the case of the "mysterious coincidences" among the viryas, which can lead one to believe in a "destiny" or some other form of determination, there is here a phenomenon of SYNCHRONY. For in all that is subject to the TEMPORAL ORDER, that is to say, to the Will of the Demiurge, the "law of evolution" and the Plan of the One is at work; but to the extent that the virya purifies his blood, there occurs a SPIRITUAL DISINCRONIZATION with this ORDER (of which we shall speak at length). This DISINCRONIZATION with the Satanic Plan generates, within the framework of a Hyperborean Mystique, the SYNCHRONY between the viryas and the Siddhas. And this SYNCHRONY is, for those who attain the Mystery of the Pure Blood, present in ALL CONCRETE ACTS, INCLUDING IN THE LINGUISTIC CO-MUNICATION.

Hence, the famous "esoteric concepts" and "universal sacred symbols" that the "esoteric rationalists" wield as PROOF or EVIDENCE of a SECRET DOCTRINE or "common esotericism", do not have and will never have the same meaning for the different viryas. And if any of them, upon contacting each other, use them as PROOF or EVIDENCE of a SECRET DOCTRINE or "common esotericism".

In their linguistic communications, this coincidence of words and concepts must be understood simply as a phenomenon of SYNCHRONY. That is why the awakened viryas, even though speaking the same language and using the same words, only coincide in the ideal content of the concepts, for they possess an ABSOLUTELY DIFFERENTIATED consciousness which can only coincide in one thing: the common center; or in the figure of the Führer, who from the common center establishes the "charismatic bond" between the viryas.

A very widespread error has become evident: the non-distinction between "linguistic concept" and "mental representation" or "idea" of the thing. However, this error can acquire very subtle variants, not so easy to appreciate, in certain "esoteric rationalists" who, while accepting the distinction highlighted, perhaps for the sake of some "idealistic philosophy", pretend to subject the IDEAS to the "FORCEPS" of the ARCHETYPES. But this "mold", this "ultimate limit" that supports the qualities of the thing, the archetype, more than FORMAL is an ONTOLOGICAL attribute, and the objection raised is thus inscribed within the field of METAPHYSICS; although it is horrifying to consider that there are those who profess a sort of "metaphysical rationalism". Let us study, finally, this variant of the error:

The "rationalist-esoteric-metaphysicists" object that there is an ultimate stage, a higher, archetypal plane, to which all ideas refer. The archetypes, pure symbols emanated by the Demiurge, enclose the ontological essence of all that exists and are the ones who determine as a whole the FORM of things. The IDEAS "thought" by man are, then, mere copies of his UNI-VERSAL ARCHETYPES. And since the idea of the same thing, thought by many persons, nevertheless shares a common archetype, there would be no gnoseological possibility of surpassing that archetype. In other words, "God" -the Demiurge creator of archetypes- must be at ease: man (pasu) cannot give any "surprise", he has not eaten from the tree of gnosis.

We will explain it in another way. If one thinks of an idea represented by two words - "equilateral triangle" - he will evoke in his imagination a typical "figure"; if ten think of "equilateral triangle", each of them will represent in such and such a way a typical figure; The same if a hundred, a thousand, a million or ALL MEN do so, as long as they think in "equilateral triangle" they will evoke a figure or thing which, although in each of them, in each individual consciousness, is different, CAN NEVER EXCEED THE COMMON ARCHITECTURE of all the equilateral triangles that have been or will be, thought or to be thought, from the beginning of the world until its - no doubt near - end. It is now understood that man (pasu) will not give "surprises": however he may think, in a UNIVERSAL IDEA, he will never

will originally think so.

This perspective, which subjugates the rationalists, presented here as a metaphysical objection, is COMPLETELY FALSE for the hyperborean viryas, and in no way invalidates the answer given by us to the fundamental question about the nexus between the viryas. BUT IT IS TRUE FOR THE PASU. They cannot originally think any idea because their consciousness (soul) is ABSOLUTELY DETERMINED by the archetypes. The awakened virya, on the other hand, possesses a HYPERBOROUGH SPIRIT, totally alien to the world of the Demiurge and his determination; a spirit which is PURE POSSIBILITY and is also called VRIL. Hyperborean Wisdom is "thought" with this uncreated organ, and for this reason a virya will never COINCIDE with another, neither in the PATH nor in the WAY OF RETURN, nor in anything that can be "universal" or "common". There is, as we shall see later in the Psychosocial Strategy of the SS, ONLY ONE IDEA COMMON to all viryas, and it is not archetypal. This idea is a BLOOD REMEMBRANCE which is summed up in the word ORIGIN.

That one element common to all viryas, the primordial origin, is what constitutes the FACT OF THE RACE; and that is why the Hyperborean Wisdom calls the origin: RACE OF THE SPIRIT. It is by virtue of the origin that ALL ACTION of the virya is ALWAYS directed towards the race, towards the good of the race, seeking its mutation.

The Hyperborean Wisdom says: "Every action in favor of the race brings us closer to the origin and to our own mutation; but every search for the origin that is carried out in dependence on the race, must ABSTAIN FROM ACTION to be effective, it must be limited to the Minne."

The attitude of John Dee, of Rudolf II and of all the viryas involved in the "Secret History of the Thulegesellschaft" must be interpreted on the basis of the articles in this chapter and their teachings. Perhaps to the rationalistic criterion it is sheer madness that several respectable people fight, risk their property and their lives for things "of no practical value". And the most incomprehensible thing, without any of them attributing to these things the same value or the same properties, acting on the basis of the intimate certainty of their usefulness; without knowing each other and even without knowing, sometimes, against whom they were fighting.

Madness, pure madness, the rationalist would say; without seeing that they are all behind that primordial fact that is the ORIGIN and that is why they coincide synchronistically in the eternal return, because the ORIGIN makes them

participate in the hyperborean race and "links them charismatically".

## JOHN DEE 17 YEARS LATER

Dr. JOHN DEE studied Trithem's Steganography for 17 years. At first he did so in secret, for he soon realized that this strange alliance of Dominicans, Jesuits and Jews to destroy Cornelius Agrippa was an admirable alliance that should not be disregarded. However, he did not associate the fate of Agrippa with the conspiracy that ostracized Trithem. In the 16th century it was extremely difficult to perceive the organized action of the Synarchy and, above all, John Dee was English. He feared and abhorred the inquisitorial persecutions of the Church, but: "that was happening on the continent". In England there were neither Dominicans nor Jews; the Jews "were given to trade or to their usual occupation: usury"; and that "absurd" comment that the Jew LAKEDEM made to him about the Fili, was not even taken into account.

This foolish "security", a psychological attitude that everyone shared in the England of Elizabeth I and which, in a certain way, is necessary in the inhabitants of a country that is intended to be elevated to the rank of "Empire", was in this case harmful to John Dee.

The research of the sage, after reading the Steganography, was centered on the "language of the birds"; that is, the original hyperborean language. As he progressed in his studies and awakened to the realities of the spirit, his philological capacity was amplified "charismatically". He possessed a true "gift of languages" and after so many years of research, he succeeded in synthesizing the "language of the birds" which he called ENOQUIANA<sup>1</sup>. But let us go by parts. When speaking of original language, primordial language or hyperborean language, we will not fall into the childish pretension that such language is the ONLY source from which ALL the languages of mankind are derived. We have already warned previously against this rationalistic error which we call "synarchic tactics". Let us note now that, consequently, the myth of a UNIQUE original language is well detailed in the Hebrew Bible, in which the story of the Tower of Babel is transcribed.

The curious story of a tower built by the first men, who held the avowed object of "reaching heaven," has not ceased to occupy the minds of its readers, since the Bible was translated by the seventy, between the

---

1 *The concept of "BIRDS' LANGUAGE", ENOQUIAN LANGUAGE or LENGUA HIPERBÓREA is deeply developed in another part of this narrative.*

285 and 246 A.D., according to the order given by Ptolemy II. But it was not so much this objective, "to reach heaven", as the punishment imposed by Jehovah-Satan, "the confusion of tongues", that astonished the reader of the Bible. Why CONFUSION?

In the eighteenth century, for example, Voltaire, equally surprised, wrote satirically: *"I do not know why the Genesis says that Babel means confusion; since Ba, father in the oriental languages, and Bel, mean God; therefore Babel must mean the city of God, the holy city. The ancients gave this name to all their capital cities. Babel will mean confusion, either because the architects were confused after having built their work, or because all the languages were confused there; and it is evident that since then the Germans no longer understood the Chinese, although if we are to believe the wise Bochart, the Chinese was originally the same idiot as the High German"*. It is no small joke that Voltaire finds the German language similar to Chinese, but, overlooking its irony, underlying the quoted paragraph are the same questions that have been asked by thinkers for centuries. We, basing ourselves on the Hyperborean Wisdom, will give an explanation of this ancient myth while drawing from it important STRATEGIC conclusions. But let us first recall the biblical text:

#### GENESIS 11: THE TOWER OF BABEL

1 - The whole earth had one language and one set of words.

2 - But the men, when they moved from the east, found a plain in the land of Shinar and settled there.

3 - And they said to one another, "Let's make bricks and bake them in the fire. And the brick served as stone and the bitumen as mortar.

4 - Then they said, "Let us build us a city and a tower, whose top may reach to heaven, and let us make a name for ourselves, that we may not be scattered over the face of the earth.

5 - The LORD came down to see the city and the tower that the sons of the LORD were building  
men.

6 - And Yahweh said: Behold, they all form one people and speak one language; if this is the beginning of their undertaking, nothing shall now restrain them from what they have determined to do.

7 - Let us go down and CONFUSE their speech there, so that some do not understand the language of others.

8 - And from there Yahweh scattered them over the face of the whole earth, and from there they ceased to build the city.

9 - Therefore it was called Babel, because there Yahweh confused the speech of all the earth, and from there he scattered them over the face of the whole earth.<sup>1</sup>

Let us now analyze how this text is to be interpreted, using guidelines of the Hyperborean Wisdom.

1 - "Men possessed one tongue" means: the viryas possessed one PURE BLOOD and therefore they understood each other. "Men pretend to reach heaven" means: the viryas pretend to flee from the chains of Jehovah-Satan.

2 - 3 - 4 - "For this purpose they build a tower" means: the viryas use a hyperborean technique.

5 - 6 - 7 - "Jehovah-Satan notices the maneuver and decides to prevent it by CONFUSING their tongues so that they do not understand each other" means: Jehovah-Satan provokes the STRATEGIC (BLOODY) CONFUSION from which the "charismatic linkage" between the viryas is eclipsed.

8 - 9 - "After the confusion of tongues Jehovah-Satan scatters men all over the earth" means: after the confusion of blood the viryas are LOST.

It should not be surprising that in symbolically interpreting this "myth" the classic tactics of Jehovah-Satan are exposed, for it is the transcription, adapted by the Hebrews, of several ancient stories that actually occurred during this endless war. When fleeing from Egypt, Moses stole numerous papyri with stories of Atlantis; and on the basis of this material, adapting and falsifying everything, he elaborated the Pentateuch. Therefore, in the biblical text, very ancient stories are confused with the famous tower of Babylon, which, in turn, is often also confused with the Ziggurat of Borsippa: Birs Nimrud.

---

1 *THE BIBLE - Catholic Version - Ed. Herder, Spain, Imprimatur 1-VII-75 - José M. Guix, Bishop.*



Returning to our interpretation of the biblical account of the Tower of Babel, we can now understand, symbolically, that "rediscovering the original language", that which ALL ARE CAPABLE OF UNDERSTANDING, means ANNULING THE TACTIC OF JEHOVAH-SATAN. That is to say, it is equivalent to purifying the blood of the viryas, to transmuting the race "backwards", to that common origin in which there was no CONFUSION and all could orient themselves "in the direction of heaven".

With respect to the traditional expression "language of the birds", it should be clarified that it should be interpreted symbolically as a language that allows communication with the Hyperborean Siddhas. In this respect, René Guénon says, referring to another Germanic myth this time, that *"one sees heroes who vanquished the Dragon, such as Siegfried in the Nordic legend, understand the language of the birds; and this allows one to easily interpret the symbolism involved. Indeed, the victory over the Dragon has as its immediate consequence the conquest of immortality, represented by some object that the Dragon prevents one from approaching, and this conquest of immortality essentially implies reintegration into the center of the human being, that is, to the point at which communication with the higher states of being is established. This communication is what is represented by the understanding of the language of birds; for, in fact, birds are often taken as a symbol of angels ..."* The language of birds is thus the "language of angels". However, the word "bird" also has a less profound analogy than its relation to "angel", but equally significant. *"The ARUSPICES,"* says René Guénon, *(from AVES SPICE-RE, "to observe the birds") drew omens from the flight and song of birds, which is to be related more especially to the "language of the birds," understood here in the most material sense, but still identified with the "language of the Gods. for the latter were considered to manifest their will by means of such prey, and the birds then played the role of "messengers" analogous to that generally attributed to the angels (whence their very name comes, for this is precisely the proper sense of the Greek word ANGELOS), albeit taken in a much lower aspect."*<sup>1</sup>

It is that a HYPERBORROUS LANGUAGE must be similar to birds, to their flight, to their singing, something unpredictable, but nevertheless understandable to all. The important thing in the communal fact is that ALL MEMBERS UNDERSTAND EACH OTHER as accurately as possible, and this condition is by no means EXCLUSIVELY satisfied by an oral and written language such as occurs in our societies. A race which had sufficiently developed telepathy, to put it only

---

1 RENÉ GUÉNON: *Fundamental Symbols of Sacred Science* - Page 45. EUDEBA, Buenos Aires.

For example, it would not use words or grammatical constructions to communicate, but symbols that allow "bringing" the "receiving" minds "closer" to the essence of the idea thought by the "transmitting" mind. The symbols would not have to be conventional, such as our letters and signs that are learned by everyone at school, but they could be ARCHETICALLY INHERITED. Taking this example to the extreme, and considering phenomena of SYNCHRONY, one could conceive of a race such that none of its members would share with another its symbols, for each would inherit ARCHETYPICAL TENDENCIES of the type of the "patterns of con- duction" of biology, and the symbols would only be shaped after the men- tal act performs an ARCHETYPICAL METAMORPHOSIS aimed at the telepathic EMISSION of the idea. This would be a race in which each individual would possess AN OWN, personal LANGUAGE, and yet all would understand each other. In a similar way, the Hyperborean viryas can, thanks to the "language of the birds", receive a MESSAGE PRIOR to the collective transmutation, which prepares or INITIATES them for the qualitative leap; and that is why every leader who intends to use the Hyperborean Mystique must possess the keys of the Psychosocial Strategy that imply the mastery of the forgotten language.

The language that John Dee extracted from the Steganography was called by him ENO- QUIANA because of Tritheim's affirmation that by means of it ENOC had "spoken with the angels" as stated in the "Book of Enoch". This Enoch was a hyperborean virya; but his story, very ancient, was also falsified by the rabbis - although not as much as Genesis-; reason for which it was declared apocryphal, that is to say "hidden", shortly after Christianity was imposed. But since the story of Enoch is part of a larger plot, let us leave its commentary for another occasion.

John Dee developed the Enochian language during the 17 years that he had the Steganography in his possession; but he did not manage to establish "contact" with the angels during that period. This situation caused uneasiness in the English scholar because, given that Tri-Theim expressly stated that "the mastery of the Enochian language causes by that very fact an immediate relationship with the angels", John Dee could find no other explanation for their silence than to attribute it to a failure or error in his deciphering of the Steganography. Immersed in perplexity, he thought of resorting to the same system that Tritheim had tried through Cornelius Agrippa: he decided to seek help by sending encrypted messages in a book. This book was called "Hieroglyphic Monad" and it was about ... about cryptographic methods! But disguised in its text were several messages to the hyperborean viryas. It should be added that no one responded, during John Dee's lifetime, to such a strange way of asking for help.

The solution to John Dee's problem, which was none other than a total absence of clairvoyant abilities, came by way of Queen Elizabeth I who, as we

have already seen,

gave him the mirror of Princess Papan. For from the very instant this happened, John Dee's expectations began to be satisfied with such overwhelming facts that soon all his longings were fulfilled. But let us not get ahead of ourselves. As he took the mysterious stone mirror in his hands for the first time, he was irresistibly attracted by its DEEP BRIGHTNESS. It was such an intense sensation that he found it difficult to look away from it, while his body was being moved in both directions by powerful energies from heaven and earth.

However, he would receive the greatest surprise in his study, when the Unknown Superiors, the Divine Hyperboreans, the immortal Siddhas, became present before his astonished spirit. We have already said that the Aztec talking stone was an Atlantean transducer. The following must be kept in mind: such lithic instruments DETECT PURE BLOOD. Thanks to a now unknown Atlantean technology, before which our solid state electronics would pale with envy, it is possible to CALIBRATE these transducers to RESULTS with a certain human physiological constitution. The interaction between the resonant stone and the energy fields of the human body produces a "valve" effect, opening a "path" to planes other than the "physical plane". This is not the best way to exercise spiritual transcendence and, in fact, in Atlantis this system was only used for ordinary communications, as it ONLY OPERATES IN THE MATERIAL UNIVERSE of the Demiurge. But during this stage of the Kaly Yuga, our racial guide, Christ-Lucifer, is at levels of physical "quantification", as the Black Sun of the Earth, thus making it possible to establish a type of "instrumented contact" with the Hyperborean Siddhas who await, together with him, the awakening of the viryas.

This is how Princess Papan's stone mirror "worked" with Dr. John Dee's lymphatic-circulatory system and put him in communication with the Siddhas. Within a few weeks the good sage had obtained an enormous amount of instructions in the Enochian language. It was the Strategy that the Siddhas proposed to the man of the 16th century and which consisted basically of: 1° method for the formation of a rigorously luciferic human elite; 2° planning on the basis of the Hyperborean Wisdom so that such supermen (the aforementioned elite) could control the many and bring them to the point of collective mutation.

The knowledge revealed to John Dee offered marvelous prospects for reviving mankind, but it was, of course, extremely dangerous to handle if one did not act prudently. And this virtue was in short supply in our hero. So, pressed by Elizabeth I to bring forward the results of his investigations, John Dee eventually revealed to the sovereign that he had entered into a

"dialogue with angels".

In any case, this confession was taken with skepticism by the queen and other wise men and courtiers, who were soon also in on the "secret", since the mirror only worked when manipulated by John Dee. And this incredulity would have been a good thing for him, were it not that the imprudent publicity given to the matter attracted some undesirable onlookers: the Welsh Druids, who since the death of Mary "the Catholic" had been swarming around the court of Elizabeth I and, at the same time, were preparing the intrigue that would lead Mary Stuart to the scaffold. Suddenly John Dee had become, without knowing it, the most dangerous enemy for the Synarchy; and the consequence, a powerful conspiracy was going to be unloaded against him. However, John Dee's "dangerousness" did not arise from the fact that he was in possession of the magic mirror; nor did it arise from his possession of the writings in the Enochian language. Such facts were very negative for the Synarchy and surely justified by themselves a rejoinder against the sage. But what really left the Demoniacs with NO ENCOURAGEMENT was a project that he presented to Elizabeth I and which, curiously enough, is still preserved in the Royal Archives of England. We refer to the "Thule Project", conceived by John Dee between 1581 and 1587, in which he proposed the occupation of Greenland by English troops in order to "extend" the kingdom to other worlds, conquering them by fighting if necessary.

This fantastic plan, the details of which can be verified in the documents that still exist in Great Britain, was inspired by the legendary story of Nimrod, the Kassite king of ancient Assyria. Thanks to the use of the magic mirror and the knowledge obtained by means of Steganography, John Dee elaborated such a plan, which was perfectly feasible to be applied, but which we will not be able to understand correctly without first possessing the keys to Nimrod's feat. These we will try to reveal in the next chapter.

## THE LEGEND OF NIMROD "THE DEFEATED".

The content of the Thule Project caused a tremendous impact on the Santhanian hosts. It is worthwhile to make a stop in our story to know the reason for this reaction, investigating its remote causes. To do this, we will leave John Dee for a moment and move four thousand years in time. We will go to Assyria, to the ancient city of BORSIPA, and we will contemplate the tower of Nimrod. It will be a pleasant walk, tinged with teachings of the Hyperborean Wisdom that until today have been kept in the strictest secrecy. And thanks to these millenary concepts, by taking up the story of Dr. John Dee, his Thule project will be clearly understood by us.

In the 2nd millennium B.C. an invasion brought the Hyperboreans KASSITAS to Assyria. They were natives of the Caucasus and carried a sacred stone with the standard of the lion-headed eagle. The lion-headed eagle, with its wings spread, imprisoned in its claws two moruecos, which were the symbol of the Semitic God, Enlil (Jehovah-Satan), worshipped in Mesopotamia by all the tribes, among them the HAMITAN or HABIROS tribesmen, who would later go with Abraham to Palestine and Egypt. This same banner would later be carried, thousands of years later, by other "barbarian" peoples, also native to the Caucasus, this time of Germanic race, but between the claws of the eagle there were no longer the Moruecos but the lamb, symbol of that God of the shepherds who tried to usurp the millenary hyperborean figure of Christ-Lucifer.

The Kassites were following the dictates of their archer god KUS, who had made a pact with the priests so that they would participate in the cosmic war. In the city of Borsippa, north of Nineveh, king Nimrod, using the numerical technique of the Ziggurat, had a huge tower built on a vortex of telluric energy. Here is what was intended: "to attack the abode of the immortal demons", that is, Chang Shambhala. This purpose, which may seem today to be the product of an unbridled fantasy, is nevertheless perfectly possible; and the proof of it is in the success obtained by Nimrod when his ELITE OF ARCHER-GUYMEN targeted and brought down several of the "immortal demons". (There are in all this that we are narrating elements of the Hyperborean Wisdom, so that, if the truth is not INTUED through the Minne, it is difficult to understand what we are talking about).

In ancient times, when the influence of the Kaly Yuga was not so important and in some Atlantean remnants the memories of the Hyperborean Wisdom and of the war against the Demiurge were still preserved, the task of founding towns and cities demanded the assistance of specially gifted priests. The same for the elevation of idols or sacred effigies whose UTILITY, which was not mere worship, has been forgotten today. The most important element taken into account for such foundations was the LOCATION OF THE CURRENTS OF TELLURIC ENERGY. In SECOND

The astrological coordinates, to which, however, the blindness of men tends to grant preeminence in some epochs, were in the place of the astrological coordinates. Precisely, the power or survival of a city depends on the correct geographical situation in which they are erected; and if, for example, cities like Rome or Jerusalem have lasted for millennia, it is because they are settled on great centers of strength. Thousands of years ago, those in charge of determining the location of a city were called CAINITAS, sacrificial priests who knew the magic of spilled blood. These sacred murderers, who were zahori, i.e. "sensitive" to the forces of the earth, after detecting a suitable vortex, performed the human sacrifice in order to "polarize" the telluric energy and obtain a phenomenon of "resonance" with the blood of the race, so that the place would become a "friend" of its inhabitants and an "enemy" of future invaders. Of such ritual murders for foundation purposes, we remember, for example, Romulus who, to ensure the inviolability of the walls of Rome, had to execute his twin Remus; etc.<sup>1</sup>

Let us make a brief parenthesis to consult the Hyperborean Wisdom on some guidelines that must be taken into account to correctly interpret the action of war undertaken by King Nimrod.

The POWER of a people to free themselves from the satanic yoke of the Sinarthy may be properly considered to depend directly upon the esoteric-hyperborean conditions of their priests. If there are viryas sufficiently capable (awakened) to locate the currents and vortices of telluric energy, and do not despise the combat that this "taking of position" inevitably brings, then the race is on the way to mutation, it has become a "closed circle" Hyperborean. For reasons of blood purity, it is always the so-called "barbarian" peoples who are closest to these hyperborean praxes; but these same peoples, to the extent that they become civilized (or synarchized), lose POWER and, therefore, their POSSIBILITY OF MUTATION weakens. The HYPER-BOREAU RACIAL PURITY of a people is evaluated by the CAPACITY OF THEIR VIRYAS to AWAKEN.

---

<sup>1</sup> *The theory of telluric currents and their influence on human settlements is developed elsewhere in this work.*

the sanguine Minne. The HYPERBOREAL RACIAL POWER of a people is its CAPACITY OF OPPOSITION to the illusory reality of the material world. It means taking an active part in cosmic warfare and, therefore, presupposes some hyperborean strategic conception. POWER is then evaluated by the clarity of the strategic aims and objectives that the viryas are able to formulate and by the effective steps taken in that direction. The result of the action is never qualified by any material guideline; indeed, the action is never qualified at all. For the Hyperborean Wisdom what matters is the Strategy (that is: the clarity of goals and objectives and the way to obtain them, that is, the POWER). In any case, the action qualifies itself, independently of the "results". The "success" or "failure" of an action has no meaning in the Hyperborean Strategy because such words refer to concepts elaborated from an incorrect perception of the world, from maya, the illusion. This can be illustrated by an ancient Hyperborean sentence that says: "for the viryas, every war lost on Earth is a war won in other heavens".

The struggle for principles, such as "honor" or "friendship", which is the tradition of the knights, stems from a celestial or angelic chivalry that is distinctly hyperborean. The celestial chivalry of the Hyperborean Siddhas is the prototype that the virya must follow in order to participate in the cosmic war, for the OTHER MODES of this contest would not be comprehensible to him in the present state of the Kaly Yuga.

Let us see, briefly, some aspects of this prototype of the hyperborean hero in his figure of "knight-errant": The one that engages a "knight-errant" is a SPIRITUAL COMBAT because the outcome of the dispute is not decided by the skill with weapons or mere physical strength, but by the degree of justice that attends each combatant. Faith in such a transcendent principle is what makes all the previous efforts and skills put into the fight contingent. For the knight it is infallible that he who has the truth must triumph... in this or another heaven. Therefore, it is not so much the adversary or the weapons employed, not even the military training, that is of interest, as the MANNER IN WHICH THE COMBAT IS SPIRITUALLY PLACED, that is to say, the adopted strategy. History and Tradition abound in examples of "novice" squires, or young lads, with different degrees of logical ineptitude for the fight, who, nevertheless, against all odds, obtained the victory counting on truth, justice, freedom, etc., in their favor. Even if such heroes FALL on the battlefield, who can deny that the courage to take action does not mean a triumph, even if it is not clear WHERE such a victory is won?

Finally, let us say that this prototype of the knight-errant can be perceived only because he ALREADY IS in his blood memory, in his Minne. However, the Sinarchy tries to CONFUSE the virya knight by COLLECTIVIZING this wonderful



INDIVIDUAL stance through satanic organizations formed for that purpose, since Chang Shambala, or by introducing essential deviations in others that may have a hyperborean principle, such as some medieval orders of sad end.

Returning to the hyperborean concept of RACIAL POWER, we can say that, in general, a POWERFUL PEOPLE is one that, having identified the enemy, goes to war action within the framework of a "hyperborean strategy". And, in particular, that a PEOPLE OF GREAT POWER is one capable of CROSSING THE THRESHOLD and moving the theater of operations to the plane of the immortals.

There are many ways of CROSSING THE THRESHOLD. The LOST VIRYAS or simple pasús, "initiated" in synarchic Satanism, for example, do it during their "ritual death", crawling abjectly before the sinister "guardians of the threshold" (sometimes wrongly called "watchers", "vigilantes" or "egrégoros"). After demonstrating their "evolution" by means of oaths, pacts and alliances, they receive the "illumination", that is, they lose all contact with the origin and suffer the definitive enchainment to the universal Plan of the Demiurge Jehovah-Satan. Then they can cross the threshold and "participate" in a thousand different ceremonies or covens, according to the sect or religion that has "initiated" them, and which have the surprising characteristic of occurring only in the consciousness of the adept, since it is a miserable illusion. The "immortals" of Chang Shambhala will never make anyone "participate" in their meetings except to destroy them; however, there are many imbeciles who believe they know the sancta sanctorum of the White Hierarchy and its "planetary instructor", the King of the World.

But there is another and better way of "crossing the threshold," which requires no humiliations or promises, and which does not involve the total confusion of the virya's blood as in the case of synarchic initiation. It is that which consists in standing proudly, with weapons in hand, before the guardians of the threshold ... and destroying them. It will be said then, but where is the threshold? is it not an initiatory symbol? No, it is not. The synarchic strategy is based on CONFUSING, that is, to make obscure what should be clear. And a widely used tactic is to give an unreal, symbolic meaning to that which one wishes to hide and, on the other hand, to exalt as real and concrete that which one wishes to "reveal". Thus, a reality such as the existence of "induced" or "dimensional doors" is considered by sensible people as a fantasy and, for example, utopias such as communism, socialism, the UN or the World Government are fanatically considered as real possibilities.

The threshold, that is, the entrance to the plane where the immortal demons dwell, can be FIXED and OPENED if a proper technique is possessed. The Hyperborean Wisdom teaches opening "induced doors" for use in offensive tactics in seven different ways. One is using lithic technology. Another is mandalic. A third harnesses telluric energies. A fourth is phonetic, etc. But all are based on the DISTORTION OF SPACE and the interaction of planes.

Once the door is opened, by whatever system, one must proceed with energy and determination to cause the greatest possible number of casualties to the enemy. This possibility may come as a surprise, but the truth is that the "immortal demons" of Chang Sham-balá can die. These "immortals", "masters of wisdom", gurus, Druids, Sages of Zion, Men in Black, etc., are irremediably linked to the Demiurge. They are immortal as long as the material "creation" lasts, that is to say, as long as the Demiurge maintains HIS WILL PUT INTO MANIFESTATION. Their existence is the fate of the pasu: a pure illusion. That is why GURDJIEFF, in his ASHRAM of Fontainebleau, in France, answered the pasu who asked "if immortality could be obtained with his method" that "he guaranteed it within the limits of the solar system", an absolutely correct answer, but which was misinterpreted by the pasu as a mockery of the Russian Siddha.

Later on we will try to give a more complete idea about this "white" plane of Chang Shambala. For now we must bear in mind that, together with the "immortal gods", there coexist, in a higher hierarchy, the Two Hundred Hyperboreans from Venus who caused the collective mutation of the Earth and enchained the divine spirits in the man-animals, or pasu, that the Demiur- go had created. The Two Hundred Hyperboreans are the Siddhas of the Tenebrous Face of Atlantis and the Lords of the Flame of Lemuria. They are truly immortal; but since they have taken physical bodies in order to copulate with the human race, fulfilling their absurd roles of Manu, they can be violently disincarnated, an action which, apart from upsetting their plans, has the virtue of destroying the GENETIC MATRIX of the presumed ROOT RACES.

One can then kill the immortals, who are so only if no violence is exercised against them, since they inhabit a fold of space in which time trans- curves in a different way; in such a way that their bodies are kept phi-siologically stable in a "determined age". With this terrible affirmation we complete the doctrinal parenthesis that we opened above. By virtue of the above, we are in a position to interpret the feat of the Hyperborean Siddha Nimrod. For example, we can now qualify the Kassites as a GREAT RACIAL POWER for having brought, according to our previous definition, to the theater of operation of the Kassites, the Kassites, and the Kassites for having brought, according to our previous definition, the Kassites to the theater of operation of the Kassites.

the lair of the immortal demons. Let us proceed, then, with the story.

We repeat what was said at the beginning. The Kassites had made a pact with their archer god Kus to participate in the celestial contest. They were fearsome warriors, perfectly capable of facing beasts, men or demons. They wandered for years until the Cainite priests decided that the most powerful "serpent of fire", that is, the vortex of telluric energy, was within the limits of the city of Borsippa, which already existed and was inhabited by a tribe of Semitic race. This did not represent any difficulty for a people determined to fight against infernal demons. In a short time the Kassites dominated the square and their Cainite priests performed the necessary rituals to "calm" the serpent of Fire.

Immediately afterwards they put into practice an adequate strategy for the imminent offensive. From it we must highlight two tasks that demonstrate the ability of the Cainite priests. The first consisted of training an elite capable of resisting the powerful magic that the "demons" would employ when "the gate of hell" was opened. This hyperborean elite, distant ancestor of the SS, would have the sacred mission of exterminating the demons, a mind-boggling task in which they would surely lose their lives or their reason.

The other task was perhaps the simplest to execute, but the one that would require the greatest skill in the handling of the Hyperborean Wisdom: to build the "magic tower" that, thanks to the harmony of its exact dimensions, its form and its functionality, would channel the telluric energy DISPERSING it around the "eye of the spiral" of energy.

In temple architecture, the most important thing, from the point of view of "ritual functionality", is the base plan, its symbol. The most commonly used are: the circular, cross or octagonal base, although they have also been built with a rectangular, pentagonal, hexagonal, etc. base. But in the hyperborean architecture of gue- rra, buildings similar to "temples" are usually constructed whose base plan is almost always a "labyrinth". Such a figure must be used due to technical requirements of the channeling of telluric energies; and we can add that the application of the "labyrinth technique" is another of the seven ways of "opening induced doors". Of course, we keep repeating that the products of these hyperborean techniques are not automatic, i.e., they include in their functionality the participation of trained viryas.

Nimrod's war plan consisted, then, of three steps: 1° opening the door to the Chang Shambala plane; 2° accessing the famous threshold of synarchic initiation;

3° attack, attack, attack ...

Complementing this colossal strategy, there were a series of logistical details, such as the choice of weapons or the possibility of using the ancient "magic armor" of Atlantis. Regarding the weapons, the Cainite priests decided that the warriors would use arrows built according to an ancient formula: the feathers would be of ibis; the shafts, of Caucasian acacia; and the points, of stone, would be small perfectly conical stalactites, collected from deep and mysterious caverns that a shaman tradition affirms are connected with the hyperborean kingdom of Agarta.

As for the "magic armor" it is easy to imagine today, in the light of modern electronic technology, what a "material precipitating electrostatic field" enveloping the whole body would look like. However, this "electronic armor," called magic in the time of Nimrod, was a common defense in the days of Atlantis, up to about 12,000 years ago. The Cainite priests only managed to endow King Nimrod and his general Ninurta with such a protective field for a few hours, since no one else in the village had the necessary purity conditions to apply the very ancient technique. Only two warriors when Atlantis had entire armies that used the "metal coat"! This technique underwent a slow degradation until it disappeared completely due to blood confusion. At first, when the Siddhas came to Earth millions of years ago, they clothed their physical body with a "fire armor". Then, in distant Lemuria, the priests, kings and warriors, materialized minerals so they used to be called "stone men". And finally, in the middle of the Atlantean Kaly Yuga, the Siddhas of the Tenebrous Face materialized metal breastplates around their bodies, which protected them from sword or spear blows in the manner of our medieval chain mail. The Atlantean armor of materialized metal is, on the other hand, the origin of the Jewish legend according to which Nimrod possessed the "garments" that Adam and Eve wore in paradise. He would have obtained them from Ham, one of Noah's sons, and later, after fighting with Esau, another great hunter, he would have lost them. These legends are found in the Talmudic Midrash Sepher Hayashar (12th century) and Pirque Rabli Eliezer (90 - 130 A.D.) and also in the Babylonian Talmud (500 A.D.), etc.

The guardians of the threshold also have powerful armor and weapons, among them, for example, the "OM ray", an Atlantean weapon with which the gentle "masters of wisdom" of Chang Shambala often disintegrate wayward disciples.

He looks like a terrible enemy thus armed, but that is pure appearance, only material power. Nimrod's warriors would bear the Hyperborean sign of --H-K, the rune of fire that no "immortal demon" can face. Much less the Two Hundred Hyperboreans of the Tenebrous Face. This sign represents for them THE TRUTH, the inevitable memory of the abandoned divine origin. And, like the Gorgo-na, it is not possible for them to look at it without serious risk.

When the tower was ready, a metallic column of iron, copper, silver and gold, topped with a gigantic emerald, was placed in the temple at the top. This stone had been given to the Kassites by the God Kus when he promised them to fight with the Demiurge Enlil (Jehovah-Satan) whose dwelling was in Babylon. And as the priests whispered, the sacred stone had been brought from Venus by the Gods who accompanied Kus when they arrived on Earth, before man existed. During the many decades of the journey of the "barbarians" from the slopes of Mount Elbrus in the Caucasus, the possession of this "present from heaven" was the stimulus that made it possible to face all kinds of hardships. It was the CENTER around which the race was FORMED; it was the ORACLE that made it possible to hear the VOICE of the God, and it was the RULING TABLE where the names of the kings could be READ. It was also the PRIMORDIAL SIGN before which the demons recoiled in terror and against which no infernal power had power. Through it THE GATE OF HELL WOULD OPEN IN HEAVEN and the relentless combat could be engaged against the servants of the one who enchained the divine spirit in matter. Many peoples have been called "barbarians" by other more "civilized" peoples, alluding to their "savagery" and "unconsciousness". But one needs to be a "barbarian" to make a pact with the Gods and take part in the cosmic war. Only the GUARANTEE of the blood purity of some "barbarians", fearless and immune to satanic jealousies, can decide the Gods to put in the world the CORNERSTONE of a sacred race. In other words, the "traps" - the temptations of matter - are everywhere; and that is why it is necessary to be "barbarian" or "fanatic", but also naive, "like a child", or like Parsifal, the pure madman of the Arthurian legend.

Once the construction of the Ziggurat was completed, messengers were sent to the remaining Kassite cities and villages, for their kingdom included Nineveh and other minor cities, as well as numerous northern encampments reaching as far as Lake Van and even reaching the slopes of Ararat. Thousands of ambassadors were arriving at Borsippa to appreciate the tower of Nimrod and to pay homage to ISHTAR, the Goddess of Venus, and to Kus, her racial God, husband of Ishtar. A small number of their Hittite cousins, with whom the Kassites had set out together many decades before from the Caucasus, also arrived from the south, from Bavaria, which they had just conquered.

Everything was prepared for the summer solstice, the day when Chang Shambhala is "closer" to our physical plane. That day the people of Borsippa were gathered at the Great Ziggurat and a contrast of emotions could be seen on all faces. The Kassite invaders, hunters and farmers, that is to say, Cainites, were openly demonstrating their wild joy at the culmination of an enterprise that had absorbed several generations. And in that furious joy beat the longing for the next combat. An ancient Aryan proverb says: "the fury of the warrior is sacred when his cause is just". But if this thirst for justice leads him to face his enemy a thousand times superior, then NECESSARILY a miracle must occur, a mutation of human nature that takes him beyond the material limits, out of Karma and the eternal return. Leonidas at Thermopylae is no longer human. He will be a titan, a god, but never a common man. That is why the people of Nimrod in their holy fury sensed the next collective mutation; they felt elevated and saw the deceptive reality of the Demiurge Enlil dissolve. They boiled with courage and thus drastically purified their blood. And in that pure blood, bubbling with fury and courage, as it gathers in the temples, it brings the memory of the origin, awakens the Minne and makes the primordial images parade before the inner sight. It SUSTAINS, in a word, from the miserable reality of the world and TRANSPORTS to the true spiritual essence of man. In these magical circumstances it is not strange that a whole people gain the immortality of Valhalla.

In contrast to this warlike euphoria, there was an anguish portrayed in the faces of numerous citizens. They were those who constituted the primitive Semitic population of Borsippa, shepherds and merchants, who had always worshipped the Demiurge Enlil. According to their traditions, Jehovah Satan had preferred the shepherd Abel and despised the farmer Cain (which is coherent since "shepherd is the office of the pasu", son of Jehovah, according to the Hyperborean Wisdom). For these reasons, they had a deep hatred against king Nimrod and the Cainite priests. A hatred such as only cowards can feel, those who, in everything similar to the sheep and sheepfolds they feed, call themselves "shepherds". This hatred of the warrior is that which, hypocritically disguised, exalts the "virtues" of sentimentalism, charity, fraternity, equality and other falsehoods that we know very well from suffering them in this CIVILIZATION OF SHEPHERDS into which the Judeo-Christianity of the Synarchy has plunged us. And that hatred, which we are considering, arises and is nourished from a source called FEAR.

Fear and Courage: here are two opposites. We have already seen the transmuting power of courage, whose expression is the warrior's fury. Fear, on the other hand, is expressed by faint-hearted and refined hatred, which after multiple distillations gives rise to envy, resentment, slander and all kinds of insidious feelings. Fear is therefore

a poison for the purity of blood, as courage is an antidote. The exaltation of courage elevates and transmutes; it dissolves reality. The exacerbation of fear, on the other hand, sinks into matter and multiplies the enchainment to illusory forms; it increases the "participation mystique". That is why the Semitic shepherds of Borsippa mumbled the prayers of Enlil while, as if hypnotized by terror, they watched the Cainite ceremony.

Early in the morning, when Shamash, the sun, had just awakened, the drums and flutes were already electrifying the air with their monotonous, ululating rhythm. On the various terraces of the Tower the priestesses danced unrestrainedly while repeating incessantly Kus, Kus, invoking the God of the Race. The priests, seventy in number, officiated the pre-battle rites installed around the enormous labyrinthine mandala built on the floor of the upper temple with lapis lazuli mosaics, an exact replica of the labyrinth at the base of the Ziggurat. Throughout the temple the color blue predominated, standing out with an intense and titillating brilliance the great green emerald consecrated to the spirit of Venus, the goddess that the Semites called Ishtar and the Sumerians called Inanna or Ninharsag.

While the priests remained under the roof of the upper temple, in the side corridors, King Nimrod and the two hundred warriors were preparing to die.

The climax of the war was "in crescendo" as the hours passed. Near noon an ectoplasmic, ash-colored vapor could be observed seeping through the columns of the upper temple and rotating languidly around it, returning in its capricious volutes to the imperturbable warriors. Inside the temple the vapor covered the entire enclosure, but did not exceed the waist of the tallest of the priests.

The crowd that remained petrified observing the top of the huge tower suddenly witnessed, astonished, a phenomenon of vapor embodiment. At first only a few noticed it; but now it was visible to all: the cloud adopted definite forms that remained for a moment to dissolve and become corporeal again. The main "motif" of the mysterious reliefs of the vapor were mainly figures of "angels". Angels or Gods; but also Goddesses and children. And animals: horses, lions, eagles, dogs, etc. And chariots. It was a whole celestial army that materialized in the vaporous cloud and rotated slowly around the temple. And as the chariots passed, drawn by spirited winged steeds, the warrior angels clearly encouraged Nimrod. So did the women; but it is well to dwell for a moment upon

Oh, the Hyperborean women! So beautiful! They wore a short skirt girded at the waist by a thin cord from which hung, at the side, the sheath of a graceful and fearsome sword. The bow crossed over the chest and on the back the nourished quiver. The gold and silver braids of a hair that seemed as soft and light as the wind. And the faces, who would be able to describe those forgotten faces, after millennia of deceit and decadence; faces that, nevertheless, are engraved with fire in the soul of the warrior, almost always without his own knowledge? Who would dare to speak of those sparkling eyes of cold courage that irresistibly incite us to fight for the Spirit, to conquer the Vril; eyes of steel whose gaze tempers our spirit until the moment before combat but which, after the fight, will miraculously be like a balm of frozen love that will heal every wound, soothe every pain, and resurrect the hero forever, the one who tenaciously remains on the path of return?

And who, finally, would dare to even mention their primordial smiles before which all human gestures pale; before whose singing sounds the music and rumors of the Earth are extinguished; transmuting laughter that could never resonate among the misery and deception of material reality and that, therefore, can only be heard by those who also know how to listen to the Voice of pure blood? It is impossible to attempt to sketch the purest image of those hyperborean women, eternal companions of the Siddhas, whose projection in the ectoplasmic vapor was produced thanks to the powerful will of the Cainite priests. We will only add that these images were enormous. As the other figures rotated at a certain distance from the Kassite warriors, they detached themselves to embrace and caress them, and then their size could be appreciated. They were twice the height of King Nimrod, the tallest warrior of Borsippa.

The people clearly saw these effusions; and although it was evident that the Goddesses spoke to the warriors in imperative tones while pointing to the sky, none of them could have heard if those phantoms really emitted any sound; for the frenetic rhythm of the flutes, drums, tympani and harps was deafening. But perhaps the hyperborean women were speaking directly to the spirit; perhaps their voices could be heard inside each warrior as they say the augurs feel...

Enveloped in this frenzy, but momentarily stunned by the alterations of the white cloud, the citizens of Borsippa did not notice when one of the priestesses left the dance. She ran up the remaining floors to the temple; but before she entered, the vapor took the form of a multitude of winged children who hovered around her and showered upon her head, "I am not a priestess," she said.



etheric liquids from no less etheric amphorae. However, such supernatural manifestations did not stop her. Anointed from head to toe by the graceful kerubes, she advanced resolutely and entered the temple. The seventy priests, upon witnessing her irruption, ceased all chanting, all invocations; and turning toward her, they stared at her. At last the priestess stopped her light step forward of the entrance to the labyrinth and, without a word, pulled a cord and dropped her robe, leaving her completely naked ... except for the jewels. These were exceedingly strange: four gold SERPENTIFORMES bracelets, which she wore wrapped around each ankle and each wrist; a necklace similar to the bracelets; a tiara studded with milky, opaque stones; two earrings and two serpentiform rings; and a red stone in her navel.

Of the whole ensemble, what was most impressive for the exquisite design and the skill of the goldsmiths, were the bracelets. Each one had three turns; those on the left leg and arm with the snake's tail facing outwards and the flat head towards the inside of the body; the bracelets coiled on the right leg and arm, showed the snake as "coming out" of the body; on the necklace, the snake pointed its tail towards the earth and the head, strangely two-headed this time, was just under the chin. All the snakes had small green stones embedded in the eyes, and the body was carved and enameled in bright colors. On seeing these marvelous pieces of goldsmithing, no one would have suspected that they were actually delicate instruments for channeling telluric energies.

The girl is breathtakingly beautiful. We can observe her as she walks with a sure step through the labyrinth that she seems to know very well, since she is almost indistinguishable from the floor, under the dense cloud of ectoplasmic vapor. If she were to take the wrong path, if she were to hit a fence, it would be taken as a bad omen and the operation would have to be suspended until the following year. But the priestess does not hesitate, she keeps her thousand eyes of blood open and sees down there, at the base of the tower, how the telluric energy, like an irresistible serpent of fire, also runs through the resonant labyrinth. And everyone trusts her, in the terrible mission she has undertaken, which begins there, but continues in other worlds. They trust her because she is a magician priestess, born fifth in a family of dowzers, with blood so blue that the veins are drawn like dense trees under the transparent skin. They all think of her as she walks through the labyrinth singing the hymn of Kus.

The priests hold their breath as the slender legs of the sacerdotisa deftly traverse the last stretches of the mosaic-labyrinth: she is about to reach the "exit". She has triumphed! But this triumph means death, as we shall see shortly. Just at the end of the labyrinth is the stone and metal column

where the hyperborean emerald shines with rare brilliance. The priestess stops in front of it and, raising her eyes to the sky, ascends the three steps that lead to the base of the column, which is of low height because the emerald barely reaches the level of her pubis. Curious thing: the emerald has been carved in the shape of a vagina, with a central slit, which is possible to see because it is on the upper facet, which is facing the roof of the temple. On the other hand, although the priestess is naked, it is not possible to observe her sex because a fold of flesh covers her lower abdomen, which is absolutely hairless. This physical characteristic, which today only the Bushmen women retain, is the most evident proof of their Atlantean-hyperborean lineage. Cro-Magnon women had a "natural skirt of skin" and so did the Egyptian princesses of the first dynasties, as can be seen in numerous bas-reliefs.

The priestess has traveled through the labyrinth, "guided" the serpent to the upper temple and led it through the column of stone and metal. Now its fiery head begins to press under the hyperborean emerald, magically igniting it and bathing the enormous enclosure and all its occupants in green light. Outside, the rumbling of drums and flutes has become so fast-paced and intense that it is impossible to think or do anything but contemplate the Ziggurat, the temple at the top, surrounded by Nimrod and his archers. The latter, meanwhile, watch through the columns the scene within, invisible to the people gathered at the base of the Ziggurat.

It is already noon, the precise moment when Shamash is on high. The deep voice of one of the seventy priests addresses the beautiful priestess, speaking in short phrases, pronounced with the cadence of a ritual prayer:

*- Oh Princess Isa:*

*The fate of the race is in your hands.*

*We have traveled many lands  
and crossed countless countries  
to get here, seeking to fight the  
final battle.*

*Years of roads and hardships  
since we left the sacred mountains*

*where we were born twice  
and at the top of which Kus gathered us  
and told us about the Primordial Times. We  
knew in those distant days  
THAT WE ARE NOT FROM HERE.  
And, after remembering our divine origin,  
How could we remain there, deceived  
by Him, the "old man" Enlil? Yes,  
everything became debased before our  
eyes. The fields suddenly withered, the  
flowers became horrible in their  
perfume,  
and the heat of Shamash no longer seemed good to us.  
Suddenly we saw the stunted ears of corn  
and even the mountains lost their imposing height.  
All that happened when we looked at the  
world after the sage Kus  
would speak to us of the forgotten sky,  
filling our chests with nostalgia. It was  
then that we decided to set out on the  
path back home.  
and collect the betrayal of the demons  
who had deceived us with their magic.  
Many of us set out from the  
sacred mountain in different  
directions.  
And many are the kings  
that with its hyperborean peoples  
have been looking for  
the way to Heaven.  
But Kus had warned us that  
some would not arrive soon if  
they were fooled again.  
by the cunning demons.*

*But to us he directed us accurately  
because we have no other purpose.  
than to conquer Heaven.  
We are guided by the  
invincible Nimrod, whom He  
fears.  
because their blood is pure,  
as blue as the sea  
and as red as the dawn of Shamash.  
We are a courageous people like the  
lion and we fly high like the eagle,  
but our eye is sharp  
and our claws tear the enemy to shreds.  
We are a hard people  
who know no  
forgiveness  
and gives no respite in the  
fight. We are led by  
Nimrod,  
archer like no other on earth.  
The stars drew him hunting in  
the sky.  
We carry with us the  
green stone of Kus  
so that we DO NOT GET LOST AGAIN.  
What more could we ask for?  
Stand aside, infernal demons! For there  
is here AN AWAKENED PEOPLE whom  
you will not be able to frighten!  
or ever deceive.  
On guard, you damned devils!  
For an indomitable race has arisen that  
will fight you to the death.  
Today the road has come to an  
end. Gone is the great Kash Sea*

**Nimrod from**

**Rosario**

*and the country of Kashshu;*

**107**

*buried in the trampled roads  
 our women and children, our elders and  
 the best warriors remained.  
 All have fallen for the glory of Kus  
 and for following the heroic  
 Nimrod,  
 THE LEADER WHO WILL LEAD US TO VICTORY,  
 IN THIS OR OTHER HEAVENS.  
 In Borsippa we have camped,  
 to build the tallest tower in the world and  
 tame the fire serpent.  
 There is no other Ziggurat like our  
 Ziggurat in Babylon or Assur,  
 nor in distant Egypt,  
 nor in the land of the Aryans.  
 Since the Flood covered the Earth  
 and punished the Devils  
 that inhabited the islands of Ruta and  
 Daitya have never seen another tower  
 like it.  
 The gods rejoice over us and the  
 demons fear us.  
 How hard we have worked to build it! Oh Isa,  
 this effort must not be in vain.*

The priestess was in the same place, standing in front of Kus' emerald, keeping respectful silence while her beautifully slanted eyes remained fixed on the priest. The priest continued his monologue:

*We have come this far to die fighting  
 and you, sweet princess,  
 you have chosen to die first  
 to open the door to heaven.  
 We will punish the demons*

**Nimrod from  
Rosario**

*and avenge your death, divine Isa,*

*daughter of the Serpent of Venus!*

The beautiful Cainite priestess paled visibly; however, her eyes blazed fiercely as these brave words sprang from her mouth:

*- The builder of worlds of illusion, the  
infamous Enlil,  
has sunk into an eternal sleep,  
while his fecundated body is born  
and reborn in all that exists. He  
has allied himself with the demons  
that inhabit Dejung,  
the city cursed a thousand times,  
the city of horror and deception  
whose seventh wall  
has a hidden entrance  
in the land of yellow men. He has  
trusted the Demons to continue  
their evil work.  
And they have chained us  
and prevent us from returning to the world of Kus,  
where the palace is located  
of the true God --H-K  
whose name cannot be pronounced  
WITHOUT DEATH.  
But, although Dejung is far away,  
its doors are everywhere.  
Dejung has seven gates  
and seven walls  
surrounding it.  
Demonia Dolma holds the keys  
but only madmen would be guided by it.  
How will the brave Kassites  
make room then?*



*climb the Dejung Fortress?  
If the demons already know  
of our holy purposes  
What if his eye is fixed on us from the  
Kampala tower?  
We will do it as our God Kus, "the  
Venusian", taught us:  
Awakening from sleep  
the wretched Enlil and forcing him  
to open the door to heaven  
and to build the bridge  
on the grim walls of Dejung  
Kampala.  
Kassite priests: All of you,  
behold, Enlil has awakened!  
The God Who Sleeps is an  
idiot, likes flutes and drums,  
dances and songs.  
and worship His name, But  
He also desires blood for He  
is the father of thieves,  
of dirty shepherds and sacrificers.  
Only PURE BLOOD will  
bring forth the monster  
from the depths.  
Proceed, Priests! Isa is  
ready to die in the  
war, of all, the first!  
I will travel through the  
worlds where the dead  
watch, the demons lurk.  
and the Gods are waiting.*

*I will be accompanied by Kus,  
whom everyone  
respects. And in the  
name of Nimrod, I will  
compel the beast  
to open the doors  
for the good of our endeavor.  
Proceed, Priests, for  
Isa is ready!*

At that moment three things happened simultaneously: the sun reached its zenith; the music suddenly ceased, flooding the ears with silence; and with a precise stab the priest cut the life of the beautiful princess Kassita. The jade knife cleanly slit the snowy neck above the two-headed necklace. Two priests held the lifeless body as the blood gushed over the glittering gem and into her inner cleft, now turned into an avid throat. Then began to happen the most marvelous things that human eyes had seen since many centuries ago.

Those inside the temple were able to contemplate a terrifying scene: as the blood fell, the light emanating from the emerald was extinguished for an instant, but then, like an arrow, a column of fire rose swiftly from the floor of the temple, enveloping the pedestal and the gem. The body of the princess lay on the floor, impossible to see beneath the impenetrable clouds of geoplasmic vapor that grew thicker with every instant. However, a spectral image, with its same naked beauty, could be clearly observed next to the column of fire, engaged in a kind of struggle. The igneous portent, which at first was no thicker than an elephant's leg, was now as wide as a six-man circle. Initially it had meandered fiercely, resembling a fierce ophidian; but then, as it expanded, it slowly took on the unmistakable figure of the Dragon. It was a flaming Dragon whose frightful image became clearer and clearer as the struggle with the ghost of Princess Isa increased.

It should be clarified that only a few minutes had elapsed from the time the princess expired until the moment when the fire monster materialized. It is necessary to clarify this because from then on everything happened too fast ... or perhaps the witnesses lost track of time. or perhaps the witnesses lost track of time.

Suddenly, the jaws of that primitive beast, that Leviathan, Rahab, Behe-Moth or Tehom-Tianat, exhaled a terrible roar at the same time that an enormous blaze swept the room, consuming and charring numerous priests. Only the survivors were able to observe the incredible spectacle of that fiery beast being RIDDLED by the dead priestess. Princess Isa, her ghost, had climbed onto the monster's head by sitting between the triangular fins of its camel's back. This bold action caused the monster to emit the infernal roar and deadly flame. Notwithstanding such a reaction and the fierce jerks of the beast, the princess imperturbably repeated these words:

*- Spirit of Enlil, of Him, of Yah and of Il  
who fertilizes the Earth.  
and produce life  
and deceive men  
with your false opulence  
and those illusory riches you offer. God  
you were once on high but now you have  
fallen.  
and you have become a complete  
idiot, don't chain us too in this hellish  
universe.  
you have built  
imitating the real sky.  
WE WILL LEAVE  
because we've had enough of  
you, of all your traps,  
and of the demons that support you.  
Open the gate of heaven,  
Builder of Worlds!  
Open the entrance to the infernal den  
where your cowardly henchmen dwell!  
I conjure you to do it, El,  
in the name of the true God,  
father of Kus,*

*whom you betrayed!*  
*To --H-K!*  
*I conjure you to open the*  
*door in the name of --H-K!*

At the sound of this blessed name, the beast instantly retreated to the floor of the temple, coiling around the stone and metal column. Its head, however, swayed menacingly without this boast affecting the presence of the spectral priestess, who kept a firm grip on its back. The telluric dragon showed no intention of obeying, an attitude that prompted the mercurial princess to act drastically. Leaning down, she stretched out her hand, making the gesture of touching her own blood in the socket filled with the hyperborean emerald. Then he said:

*This blood that has been shed today*  
*and into which you have rushed,*  
*Lord of all things,*  
*is my blood; a sacred blood of the*  
*lineage of the Gods of Venus.*  
*In it IS THE REMEMBRANCE*  
*of our celestial origin and*  
*of the true God --H-K.*  
*With its substance I have smeared my*  
*fingers and now I will trace on your*  
*forehead*  
*the primordial sign of --H-K.*  
*There is no defense against it.*  
*I conjure you to open the door,*  
*Enlil, king of shepherds,*  
*by the name of --H-K*  
*and its sacred sign!*

The princess quickly drew a symbol on the monster's forehead; and lo and behold, the greatest prodigy had not yet been achieved. The horrible creature of fire shot upward, like a spring, piercing the roof of the temple and carrying on its head the beautiful rider.

Those outside, in the corridors of the Ziggurat and around its base, were still silent; for only a few minutes had passed since the music had ceased, and because the terrifying roars emitted by the monster, invisible to them, were enough to silence any throat. Just as the princess drew the primordial sign and the dragon rose, a scream of terror burst from every mouth. Just above the temple, not far from its roof, the sky was torn as if a cloth had been torn. A black opening was now clearly visible to all who witnessed the strange phenomenon. And the most curious and ANORMAL thing was that the dark hole TOTALLY HID the Sun, even though the Sun, being much higher, SHOULD be seen from some distant angle. However, no one saw the Sun anymore, although its light continued to illuminate the noon as if it were at its Zenith. It is understandable that, subjected to such intense emotions, no one cared about the fate of the Sun, for while terror had paralyzed the cowardly Semites, the Kassites howled with fury, raising their fists to the sky. The spectacle was impressive and justified any distraction. The fire monster, after the gate of heaven had opened, had been totally transformed. At first it seemed as if the dreadful head had entered the gloomy opening, for only a glowing cylinder, like a beam of fire, was visible, emerging from the temple and reaching into the heights. But it was soon evident that a metamorphosis was taking place; and after a few seconds, a new prodigy offered itself to the astonished sight of the inhabitants of Borsippa. First it became bulbous and covered with protuberances, while it changed color and turned brown; then, very quickly, the bulbs extended outward and transformed into sharp branches covered with sharp barbs and some green leaves; just a few seconds later, it was a gigantic hawthorn tree that stood, unusually, over the Ziggurat of King Nimrod.

From the base of the tower, only part of the trunk and the upper foliage could be seen, for the crown seemed to be lost inside THE DOOR of heaven, while the root remained hidden from view inside the temple. But what is worth noting is that as soon as the metamorphosis was completed, all vestiges of fire, energy or plasma disappeared, and the phenomenon stabilized, producing no further changes. It would then seem as if the hawthorn tree had always been there ... were it not for the sinister tearing of the sky that egregiously suggested all kinds of abnormalities and alterations of the natural order.

But no one had enough time to be horrified. No sooner had the sky OPENED than two figures ran swiftly to the last ramp, the one leading to the terrace of the temple, and there they drew the bows pointing towards

the threshold. Nimrod and Ninurta, the king and the brave general, were the only warriors who possessed the metal armor and therefore advanced first, protected by the elite archers.

The king and the general were aiming their bows into the darkness of the opening trying to discern a target; when suddenly two figures emerged, each wielding a sword. The demons, looking like "white men", five cubits tall, seemed to float in the air; but somehow they gained a foothold as they managed to unload their swords on the heroic archers. The blades flashed as they flew through space, but bounced off without penetrating the breastplates of Nimrod and Ninurta. However, the impact caused them to roll stunned on the roof of the temple, which served as the last terrace.

A rain of arrows then fell on the "immortal demons" and, although many of them bounced off their breastplates, many others penetrated and riddled them with bullets. The badly wounded giants fell down next to King Nimrod, who quickly decapitated them, holding up their huge heads before the cheering crowd.

While King Nimrod did this and then threw the bloody trophy into the crowd, General Ninurta, accompanied by part of the warrior elite, began to climb the Enlil tree that linked the sky with the Earth. For the first time in thousands of years, a group of Hyperborean viryas were preparing to take Chang Shambhala by assault!

We beg the reader to allow us to pause in the story, so that we may express in a poem what passes through our spirit when we evoke the last marvelous deed of those hyperborean people who KNEW WHAT THEY WERE DOING in the midst of a world that was pure confusion. Then we will take up the story again at the precise moment when Nimrod's warriors were preparing to invade the threshold of synarchic initiation.

*Brave Kassite warriors!  
Your feat will eternally enlighten all  
Hyperborean peoples.  
who decide to take the sky by storm  
and return to the primordial origin  
of which Jehovah-Satan has deprived us.*

*Because they fought the demons and  
woke up from the Great Deception.  
but so far no one has managed to  
equal the glory of Nimrod, "the defeated one".  
That is why those of us who are  
left here must try again with  
Christ-Lucifer, "the one sent".  
The God of those who "lose" during the Kaly  
Yuga and his warrior monks, the Hyperborean  
Siddhas who wait for the appointed time  
in which twelve men  
of the purest blood  
meet at the end of the Kaly  
Yuga on American soil.  
Then the Graal will be found and  
after a thousand years of  
betrayals  
the blindfold will fall from the eyes,  
awakening; the door will be opened  
again  
and Chang Shambhala with his demons  
will definitely be annihilated.  
But so far no one has succeeded in  
equal the glory of Nimrod, "the defeated one".  
It is true that few tried: some Iberians,  
some Celts, Trojans, Achaeans, Dorians  
or Romans, many Goths and many  
Germans.  
But no one has so far succeeded in  
equal the glory of Nimrod, "the defeated one".  
Perhaps in Montségur, the Cathars  
or the Teutonic Knights  
of Frederick II Hohenstauffen,  
or the greatest of them all, our  
Führer, with his magic axis*

*and a courageous people who will not shrink from anything; perhaps He, like no one else, has sought it.*

*And so many have won eternity and left this hell.*

*But not definitely*

*for a final war will be waged and*

*Nimrod will return*

*with the great heroes of the past. Odin,*

*Wotan, Lug and Wiracocha,*

*Heracles, Indra and Quetzacoatl*

*from Valhalla will arrive singing*

*surrounded by beautiful Walkirias*

*and music of yesteryear.*

*And they will raise huge armies of*

*the living, immortal and resurrected;*

*a single virtue will be demanded:*

*is called HONOR and dignifies the*

*virya who has awakened from*

*Deceit.*

*The fight will be definitive*

*and the Demiurge and his hosts,*

*defeated, will at last liberate the*

*immortal spirits that had come from*

*Venus*

*to return to where God is waiting, in a*

*world that has not been created.*

*And from the Universe of matter,*

*from madness, evil and the Great*

*Deception, the returnees will sing in*

*chorus*

*the exploits of Nimrod, "the defeated"!*

Let us now proceed with the story. The Enlil tree had straight, spaced branches, which were actually huge spikes, so that it could be climbed as if it were



**Rosario**

a gigantic ladder. This was just what the Kassite warriors did, preparing to climb up the tree and lay siege to the "gate of heaven". No sooner had General Ninurta and fifty warriors climbed far enough,

They found that they were standing at the entrance to a cavern, or the image of one. They boldly jumped down from the tree, not yet knowing whether they could set foot in the mysterious world they were entering through the "gate of heaven," and found themselves on a clearly rocky ground. Some looked back, upward, and saw the tree lost in unfathomable heights; and also the edge of a chasm, a few cubits from where they stood, through which could be distinguished, many feet away: the roof of the temple from which the gigantic trunk was emerging; the Ziggurat; the men of the town gathered around it and the walled perimeter of the city of Borsippa. In contrast to the intense light outside, where it was still midday, a soft gloom reigned in the place where they had arrived. However, there was enough light to make out the details of the sinister cavern: seven stone steps could be seen and, starting from the last one, a passage that was lost in the distance. But above the entrance, following the curve of its arch, seven triangular standards were nailed. Each bore the same legend, in as many different languages. In their own Kassita language they could read:

*Dare not set foot on this THRESHOLD  
 unless you have first died to the  
 passions and temptations of the world.  
 Here one only arrives to be reborn  
 As initiates in the White Brotherhood;  
 But to obtain such a privilege  
 It is necessary to die first.  
 Adepts: if you are still alive,  
 if the flame of primordial desire  
 still burns in your hearts, if you  
 keep the REMEMBRANCE  
 and feed the PURPOSE,  
 then run away, while there is still time!*

This was evidently a strategic maneuver. The legend, apparently intended for presumed followers of the initiation, was intended to disconcert and provoke doubt in the intruders. However, far from achieving these ends, the message drew instant laughter from the Kassite warriors.

Nimrod and Ninurta were already climbing the thorn tree, followed by another group of archers. Soon they were assembled, and as nothing was happening, they set out to enter the infernal cavern.

- *Isa, Isa!* -King Nimrod began to shout, alarmed by the absence of the priestess whom no one had seen since the Dragon had risen to the sky. At that moment someone noticed that the banners had erased their imbecilic message and rewrote themselves, persisting in their tactic of addressing the warriors with deceptively spiritual words:

- *Kassite travelers:*

*In this place only those who do not  
have a righteous heart will find  
madness.*

*and a sweet and devoted soul  
able to worship the Great Architect of the  
World and serve him in his Great Work.*

*You do not fully possess these virtues.  
However, you are fortunate, Kassites!  
Although you are mistaken in your PURPOSE,  
the fact that you have been able to get this  
far favors you; and that is why we will make  
you an offer*

*FOR THIS ONE TIME, NOW AND FOREVER:*

*we offer you to serve, together with  
us, the One, Lord of the Great*

*Breath,*

*creator of the earth, the sky and the stars, of  
countless worlds like this one,*

*and other such strange and subtle LOKAS  
that are inconceivable to any mortal. You are  
brave and pure, Kassites,*

*but you have been deceived by the demon Kus who  
showed you a non-existent paradise.*

*You must abandon it and accept the Plan of The One.*

*We offer you now to PASS THE TESTS and  
serve the One God at our side.*

*Think it through, Kassites.*

*You have killed two of our HIWA ANAKIM, the  
sacred guardians of the threshold,*

*and that is serious, for which you must purge.*

*However, we still offer you SERVIR*

*in the ranks of the Fraternity, to the only*

*God. If you decide now, if you accept the*

*deal, you must leave your weapons at the  
threshold.*

*and strip yourselves of all aggressive intentions,*

*AND OF THE CURSED SIGNS THAT YOU CARRY.*

*Do it soon, Kassitas!*

*because it is a unique opportunity that we give you.*

*Do so and you can safely pass through*

*the corridor before you.*

*But keep in mind that you must cross it*

*with repentance in your soul.*

*because you will soon arrive at a very holy place*

*called "The Temple of Wisdom".*

*where you will be initiated into the Mysteries of the One.*

Nimrod and Ninurta looked at each other hesitantly; they expected to find enemies trained for combat, but there was only stupid magic there. The banners, with the banners we have read, had mysteriously attracted the attention of the Kassites. Among the warriors some could not read, but strangely enough, the message still reached their minds. And although they did not understand many of the concepts used, they KNEW perfectly well that an attempt was being made to BUY them (whenever an OFFER was made), to bribe them to give up the fight and surrender without pre-sitting battle. The defeated Kassites, disarmed with "words"? And what would be the price charged for such cowardly surrender? Nothing less than serving the hated Enlil ... A murmur rose from the warrior elite: an attempt was being made to deceive them and their god Kus had been insulted. The blood boiled in the veins of the heroic Kassites. But the message continued:

*- If you accept our generous offer  
you will become the WARRIORS OF THE ROSE, you  
will learn the DOCTRINE OF THE HEART  
and, thanks to this wisdom, you will  
discover in your own heart Him, the  
One through whom you are  
everything,  
to the Ancient of Days,  
to the Lord of the Eternal  
Summers, to the Kumara Sanat.  
If you accept, you will always fight  
for him and for his chosen people  
HABIRU  
whose seed is very close to you.  
If you accept, you will return to the world  
as initiated adepts  
in the mysteries of the KALACHAKRA,  
the most powerful science on Earth.  
And thanks to their secrets  
you will be the greatest  
heroes,  
there will be no enemies that can confront  
you. You will be respected magicians,  
victorious generals,  
invincible kings, very rich  
men, depositaries of a  
power such as has never  
been seen before.  
You will share the glory of reigning in the  
World with HIS CHOSEN LINEAGE  
in the not distant day when  
HE, like JAVE-SATANÁS  
will be presented to a large number of people,  
worshippers of matter,  
and He will lead them with a firm*

**Nimrod from**

**Rosario**

*arm from the Synarchy of His*

*Power ...*

**125**

- Nooooo! -Do not look at the accursed banner! What does your pure blood tell you, Kassite warriors? Did we not learn from Kus, the Hyperborean, that they would try to buy our souls? And did not Kus tell us, back in our distant mountains, that giving in to the demons would be the end of us?

He drew his sword, and with a swift movement inflicted a wound on his left hand.

- Listen," he continued, "I, Nimrod, who has led you victoriously into a thousand battles, tell you that we must fight to the death these vile demons who dare not face us. I tell you that they lie, and that with their promises they only seek to lose us," he raised his hand, from which flowed abundant blood, "Here is my blood, which is the purest in the world! With it I will trace the sign of --H-K on this infernal banner and then we will enter to kill the demons. Our sign is invincible!

With his right thumb, soaked in blood, he drew the primordial sign and instantly it seemed as if a fire consumed the seven enchanted triangles.

- Let's kill the demons! -shouted all the warriors in chorus.

However, they did not manage to enter the tunnel; for the remains of the banners were still smoking on the ground when the demons of Shambhala, who were secretly observing the reaction of the Kassites, prepared to use one of their terrible Atlantean weapons: the "OM cannon". First it was a soft, piercing, high-pitched sound, like the singing of the cicada. Then it began to rise in pitch and volume until it became irresistible.

- Isa, Isa! -shouted Nimrod and Ninurta in duet.

Indeed, descending from above through the thorns of the Enlil tree, the specter of the Kassite princess was in sight. She was staring at them and seemed to speak energetically, but at first, no one heard anything; for His intensely uttered monosyllable had stunned almost everyone. Nevertheless, the faith that the Kassites felt for the priestess of Kus was impressive; and perhaps this confidence soon caused them to hear, or think they heard, her instructions.



*- All behind Nimrod and Ninurta! Stare at the sign of --H-K engraved on their backs and let the Voice of the Blood flow in you. Its rumor will extinguish anything that disturbs you. And you, you brave chiefs: you have a mighty armor; you will see that it protects you. Look to me and trust, for soon your pain will cease.*

Leaping up to the king and the general, the priestess placed her hands on the heads of our heroes, producing the exaltation of a glowing aura around their bodies. This operation produced an evident relief; for a second later, both were cursing, although they could not yet hear their own oaths.

While in heaven the events we have just narrated were taking place, below, next to the Ziggurat, the rest of the people were living curious experiences. When Nimrod threw the heads of the demons, the uproar was very great; and a few minutes later they were hanging on spears. These heads were much larger than that of a normal man, although they were not even twice as large as that of a normal man. The long blond hair framed a square face, with slanted black eyes and a huge hooked nose. The mouth had full lips, a detail that was perfectly appreciated since the demons lacked beards.

The pikes were thrust in front of the image of Kus, while the priestesses carried the huge bodies to proceed, before the God of the race, to tear out the heart of the demons. One priestess made the opening in the white chest and extracted the heart, which, curiously, was on the right side of the chest. Then she removed the organ from the other demon and, having done so, raised the bloody viscera in her hands for all to see. And here an umpteenth prodigy occurred, for, on contact with the air, the hearts were transformed into flowers, to the horror of the crowd of many women and children. They were two RED ROSES with a piece of thorny stem each, but no one recognized them, for roses did not yet exist on earth, and it is probable that they were the first to be seen by human eyes since the sinking of the last Atlantis. The priestess threw them contemptuously at the feet of Kus and they all returned to the Ziggurat where, at that endless noon, the gigantic thorn stood.

The elite of two hundred archers had already climbed the Enlil thorn and penetrated the black opening. There remained around the Ziggurat the rest of the Kassite army: the infantry, the sappers, the spearmen and auxiliaries, and numerous archers who did not belong to the elite. There were also several squads of warriors from other cities who had come to Borsippa as escorts for ambassadors and priests.

And they all raised their fists to the sky and shouted: "Kus, Nimrod, Kus, Nimrod! - encouraging their now invisible king and intimately wishing to receive the order to climb the hawthorn to collaborate in the fight. Several princes and military chiefs were with the troops, but no one would have dared to give any order without first receiving signals from Nimrod or Ninurta.

Accompanying the shouting of the troops was a chorus of women and children, who made up the rest of the people. But the Semitic shepherds HABIRU, of course, continued to be frightened, invoking in a low voice Yah, El, Il, Enlil, their beloved Demiurge. And the priestesses, who first timidly and then with some urgency, had gone up to the upper temple to inquire about the fate of the seventy priests, found that they had all perished. And so they wept loudly and cursed the sinister hawthorn. For the priests who were not burned to death when the terrible tongue of fire scorched the temple, were now strung on thick, long spikes that covered practically the entire blue enclosure. The Kassite people had lost the elite of the Cainite priests; their fate was now in the hands of King Nimrod alone!

At all this, the sound of the OM cannon began to invade the city's ambit; and soon it became so unbearable that many fell to the ground fainting in pain. A new cloud of geoplasmic vapor, now rising from the ground of Borsippa, began to invade everything. The mist rose to a height equal to half a man and covered those who fell senseless. The first to roll, almost instantly, were the Semites; men and women; children and old people; all quickly fell, struck down by the piercing sound. And then occurred, perhaps, the LAST great phenomenon of that glorious day. Suddenly, as mysteriously as it had been formed, the fog began to dissipate, revealing numerous men and women lying on the ground or trying to get up. But the wonder was that the Semites, IN THEIR ENTIRETY, had disappeared. And the diabolical sound, the monosyllable of Him, also ceased at that moment.

The Kassites, finding that the Semites were not in sight, thought that they had fled; for many of them were their slaves or servants; and this presumption increased their fury. But the Semites had not fled: their whole community experienced the selective effects of the OM cannon whose sound, suitably tuned, has the property of producing teleportation. In different places, many miles apart, the Semitic shepherds "found themselves" when they regained consciousness; and while at first they cursed Nimrod and his "magic", blaming it for their involuntary journeys, when they heard of Borsippa's fate, they thanked their God Yah for having saved them. Many awoke in

Nineveh or Assur; but others ended up in places as far away as ISHBAK, PE-LEG, SERUG, TADMOR or SINEAR. In fact, many Semitic families took years to reunite, separated by distances of two or three hundred miles, a fact that contributed to spread, in a distorted way, the feat of Nimrod throughout the Middle East. At all this, at Borsippa, an archer peered through the black opening in the sky and shouted:

*- All warriors attack! Nimrod wins!*

But let us return to the entrance of the cavern, where we left Nimrod and Ninurta. When both were convinced that the OM sonic beam could not fight them, they were ready to invade the threshold. The corridor was wide enough so that they could advance five abreast, which they did at a run. In front was the spectral figure of Princess Isa, followed by Nimrod, Ninurta and the rest of the archers, except for a dozen who remained on guard at the entrance. That cavern, built for the purpose of frightening those aspiring to serve the Demiurge, had walls covered with monstrous bas-reliefs and mysterious and ungodly legends. There were also side doors leading to certain "chambers" where the Demonia Dolma usually appears in her lewd nudity, surrounded by a court of "holy" prostitutes. She is in charge of "guiding" and bewitching the adepts who ignore the dangers of sexual magic.

This and many other hallucinatory traps, designed to confound and subdue the will of the naive aspirants who usually venture across the threshold, were mounted, lurking, all along the endless length of the sinister corridor. But none of such tricks could stop those who were beyond the senses; those who heard only the voice of pure blood; those whose determination had led them to fight in heaven.

The Kassite vanguard had covered a length of two stadiums when the tunnel ended abruptly giving place to three rooms, one after the other, in whose entrances, large inscriptions in several languages let us know that they were in the "Temple of Ignorance and Learning" or in the "Temple of Fraternity" or in the "Temple of Wisdom". The first room was empty, except for an altar with the hated symbols of Enlil. The second had two altars and two huge basalt columns at its entrance. The third boasted a sumptuous altar with a coffin and, engraved on walls and ceilings, the most obscene and accursed symbols that anyone can conceive of without losing his mind. And in all the rooms there were rich carpets and tapestries covering floors and walls, and aromatic perfumes that permeated the space, softly illuminated by several oil lamps. The

The three halls, so strangely decorated, were no doubt an unusual spectacle for those hardy men who minutes before were in a humble desert town. However, these strange surroundings could not be properly appreciated by the Kassites for the fighting began as soon as they entered the first hall. There a group of "Threshold Guardians" HIWA ANAKIM, similar to those beheaded by Nimrod moments before, were blocking their way.

In spite of having a fierce appearance and being very large in size, these spawn of black magic are not very effective for fighting. They are born of the copulation between the Siddhas of the Tenebrous Face and pasu women in the ceremony of the Sabbat, which is very ancient, from the time when these practices destroyed Atlantis. Many thousands of such beings live in Chang Shambala (or Kampala, or Dejung, etc.); they are totally imbecile and serve in the "armies" of the Great Fraternity. However, there are people more imbecile than the HIWA ANAKIM: they are those who, on seeing them, take them for "angels" or "extraterrestrials".

The Guardians surrounded a bald, half-naked old man, of yellow race, who looked like an inhabitant of the distant Kuen Luen mountains. He held in his hands a DORJE or Scepter of Power, that is, a very powerful transducer that allows one to operate as a "key" or "trigger" in all the great resonant machinery that is the material world. The scepter, a rod with a spherical head of stone, emitted a reddish ray that struck General Ninurta's chest, throwing him to the ground. But the enemy had no time to rejoice at this blow, for an accurate arrow pierced the heart of the yellow demon, causing, so extraordinary a response, great confusion among the Hiwa Anakim. Now the clash became inevitable; while some demons dragged the corpse of the old man to the "Classroom of Learning", others headed, sword in hand, towards the Kassite warriors. A rain of magic arrows fell on them; but in such a small environment, the distance was soon shortened and they had to fight hand to hand. Several demons had already fallen, riddled with bullets, and some more soon followed under the effect of the Kassite swords. Nimrod opened a clearing between many attackers and, followed by his squad, passed to the next room. There the fight became fierce, for it was evident that the number of demons was very large.

But Nimrod was feverish. He had seen, through the Second Hall, a resplendent personage, who seemed to be leading the attack. He was peering through moments into the Temple of Wisdom from a door that seemed to open into a wide courtyard; but after shouting orders he turned away to make way for other clumsy Hiwa Anakim. He was a Nephilim, a Siddha of the Tenebrous Face; but Nimrod, impressed

by his divine appearance and his great white wings, took him for Enlil himself. He took careful aim and fired as the image of the Nephilim was drawn in the doorway. The arrow traced a smooth curve in space and went to hit directly into the demon's chest, bouncing as if it had hit a hard rock.

*- Nimrod dog," cried the Nephilim, his face disfigured with hatred. Is this how you resist our offer? Now you will die, you and all yours. You will be eaten by our Hiwa Anakim who, by the way, have a great appetite.*

Having said this, he turned away from the doorway as a flock of demons stormed towards Nimrod, while he watched in horror as many Hiwa Anakim set about ferociously devouring the fallen warriors. This vision brought a shriek of horror from the Kassite king and, while his sword held the attackers at bay, he observed that the casualties were terrible among his elite archers. That was the moment he gave the order to seek reinforcements. A few moments later, thousands of warriors were storming the accursed temples of synarchic initiation.

Soon the Hiwa Anakim were overrun and Nimrod had time to gather his surviving archers. Less than half were left; but the reinforcements that had arrived were impressive, to the point that they threatened to overwhelm the three temples that had already been taken. A way out to the outer courtyard had to be attempted. Nimrod peeked through the door where he saw the Nephilim and found that it led to the courtyard of a huge palace, in the middle of a cyclopean city. A breathtaking sight.

They were in the heart of Chang Shambala, very close to the palace of the King of the World. The incantation of the Cainite priests had been so effective, supported of course by the Mystery of the Pure Blood, that the fiery serpent had breached the seven walls. The tunnel of the synarchic initiation crosses them, so that the disciples of the Demiurge can reach the Masters of Wisdom. But we should make some clarifications. In spite of all that we have seen the Cainite priests and Nimrod do, it is not magic that is the key to reach Chang Shambala, but Strategy. It would be worthless that someone could "open the door" if his spirit is dogmatized or is a victim of any of the psychological tactics used by the Great Fraternity to achieve the Universal Synarchy. Therefore, NIMROD'S TRUE DEED WAS TO CROSS THE TUNNEL.

AND THE THREE TEMPLES WITH THE WEAPONS IN THE HAND, which speaks and will speak forever of THE PUREST BLOOD ON EARTH. Because those places ARE THE MOST POWERFUL CHAMBERS OF ENGAGEMENT THAT EXIST IN THE WORLD. drug treatments that may be employed by the Health Care Services can match it, nor can they be

Western Intelligence completed with hypnosis, nor any other system of "psychic programming". Those who end up there, people useful to the Synarchy, heads of state, religious, kings, rich and influential people, presidents of corporations, etc., "return" completely bewitched, ready to work fully to fulfill their "mission". They are the "initiates" of the Synarchy; they have "died" and "been reborn"; but what has really died in them is the spirit, the memory of blood, the Minne, which now, submerged in a total STRATEGIC CONFUSION, they will never FEEL.

In the courtyard outside the Temple of Sapience, where the brave Kassites had barricaded themselves, a whole legion of Hiwa Anakim, sword in hand, and several squads of Sheidim, the earthy-skinned dwarves, waited restlessly. These huge-headed dwarves are the product of the carnal trade between the Pasu and certain animals during Atlantean black magic orgies. Transported en masse to Chang Shambala after the hecatomb, they live in dreary caverns and perform all sorts of tasks for the "Masters". Lately they have been "rediscovered" in the West as companions of O.V.N.I.S. crew members, but, in truth, they are a millenary terrestrial species. They wield a paralyzing anti-personnel weapon that feels cold and can cause fainting, but is not lethal. They are aggressive and to be feared if you do not know them and do not have the necessary knowledge to neutralize them. But when they are in danger, they are cowardly and flee in disarray. They are ferocious carnivores, but they do not like human flesh like the giant Hiwa Anakim. They are responsible for cattle rustling, mutilation of animals and blood sucking, just as the Hiwa Anakim often breakfast on unsuspecting citizens who never "reappear".

The view of the outer courtyard could not have been more horrifying, but Nimrod wished to confront the cowardly Nephilim and avenge the horrific casualties among his men by the anthropophagous giants. To this end he devised a simple strategy. He would send the infantry in a horde, followed by a vanguard of spearmen. Behind would be the elite archers protecting the rear and permanently firing at the safest targets. In the confusion, Nimrod would try to reach the Nephilim.

The Emin Nephilim, whose name was Kokabiel, one of the two hundred Hyperborean Siddhas who came from Venus, followed the path of the right hand and founded the Great Brotherhood or Occult Hierarchy of the Earth, was leading his nightmarish hosts, shielded behind a huge fountain fountain. His appearance was dazzling, for these demons are proud and take pleasure in displaying a beautiful appearance, vainly trying to compete with Christ-Lucifer, Lord of Beauty.

Nimrod gave the order to attack and a horde of Kassite viryas rushed against the tight formation of demons. The dwarves fired their "belt" weapons and caused some stumbling among the first warriors; but it was soon seen that their momentum would make it impossible to stop them in this way. Dozens of arrows began to rain down as the two vanguards collided, and a tremendous scuffle ensued. At that moment Nimrod, who had apparently headed in the opposite direction, fell in two jumps on Kokabiel, trying to slit his throat with a sharp jade dagger. This weapon, coming from China, had been recommended by Isa as a very effective weapon for slaying demons.

Rolling in mortal embrace two Hyperborean Siddhas, the white Nimrod and the dark Kokabiel, played out their immortal, illusory lives trying to stab each other. It was something not seen since 8,000 years ago.

But their bodies belonged to two different races. Kokabiel was enormous, almost twice the size of the valiant Nimrod; and this physical advantage, added to his hatred that constituted a palpable, scorching energy, put the Kassite king in trouble.

- *Die, dog Nimrod!* -howled the Nephilim, as he pressed the neck of the Kassite king, caught in a deadly wrestling hold.

- *Die and return to the hellish world of mortal humans!* -The bones of the unfortunate king began to creak.

- *Imbecile Nimrod! Did you want to conquer Heaven? The punishment will be terrible. We will chain you in such a way that you will return to mineral consciousness or, worse, to the elemental world of etheric larvae. And it will take you millennia to remove the wheel of Karma, accursed Nimrod. And with your people we will make a definitive chastisement. You will be wiped off the face of the earth! But your defeat will always be remembered by the HABIRU lineage of Yahweh.*

CRACK, Nimrod's backbone sounded mournfully as it snapped.

- *Ha ha ha ha,*" laughed Kokabiel cynically. *That name really suits you: "Nimrod the Defeated". That's how you'll be remembered, Nimrod the dog. Ha, ha, ha, ha A H H H A H A!* -howled the Nephilim horribly as he realized that the jade knife had penetrated to the hilt in his waist. At every moment of the struggle Nimrod had tried to plunge the weapon, but it slipped in the electrostatic armor with mineral precipitation that protected him. At last, when he felt himself dying, he diffused

his consciousness into the



blood, hyperborean fashion, and let the last effort of his arm be guided by primordial impulses. And then the hand, fearsomely armed, shot straight to a point on the Nephilim's waist, just above the liver, where a vortex of chakra generated a weak point in the armor.

Now Kokabiel was dead and would never live again in this Universe, such is the Mystery that the Nephilim demons of Chang Shambala try to hide. But Nimrod agonized beside the gigantic corpse ... When Kokabiel fell, a sudden bewilderment arose among the demonic hosts. However, the voices of other cowardly Nephilim urged them to fight without retreat. The slaughter was terrible and blood already covered much of the courtyard, strewn with hundreds of corpses. A squad of sappers began to set fire to the adjacent corridors and soon burned the palace, which was evidently evacuated. In the midst of the confusion some warriors sat the archer king against the rumbling fountain and saw him smile as the flickering of the ravenous tongues of flame cast dancing shadows on his face. They also saw him speak to the specter of Isa. And some could even hear clearly what they were saying:

*- Oh, Isa, where have you been, princess?*

*- Far away, brave Nimrod," answered the dead priestess. The fire monster Enlil transported me out of the earthly world, to the home of his master Shamash, the Sun. There I saw a city of fire, with the most hellish demons that anyone can imagine. There were eleven Enlil-like "Gods". And one, O Nimrod, who cannot be described by any mortal without running the risk of losing his courage. The most dreadful and abominable monster that can be imagined in an eternity of madness. And he dwelt in Shamash! And everything, O Nimrod, everything in existence, everything that we saw here, in this hell, and in the many other worlds that the monster traversed, was alive, throbbing and part of him! But you must rejoice, O Nimrod, because not even He could with the primordial Sign of --H-K. - Become a tree! -commanded Shamash to the monster Enlil, "and confound in the primordial gnosis of your fruits that SIGN which reminds us of the INCOGNOSCIBLE!*

*Suddenly, O Nimrod, I found myself at the top of a thorn tree that hung down from black abysses and reached as far as Shamash. I began to descend and many infernal creatures stalked me, but they all fled when they saw that I bore the Sign. I was very worried because I had to fulfill the mission of finding the path back to the origin, as it was entrusted to us by the wise Cainites. All the hope of the race was placed on me and I could not fail. And to top it all off, I perceived the Voice of Shamash speaking to the HEAVENLY DOG and saying:*

*"O Sirius, O Zion, O Divine Can! Thy never-sullied Face must behold how the followers of Christ-Lucifer, the envoy of the Unknowable, rise up against the Plan of The One, defy the cosmic laws and seek to abandon the Universe of the Suns. Shall we, the Architects of All Worlds, allow THE SLAVE SPIRITS to free themselves from the yoke of cycles, of manvantaras and pra- layas? Answer, O Thou who dwellest in the Peace of The One. Tell us if we can accept that the Anointed Lucifer, the Christ, reveal the Mystery of the Vrill to the spirits bound to the evolution of our Holy Wills. For behold, the Envoy has installed himself in our Mansion and from there he encourages the Redemption of the Pure Blood. He illuminates the interior of the viryas as a NEW SUN THAT NO ONE SEES, a Black Sun that recalls the divine origin of the Spirit and awakens the longing for the return. Shall we permit this abomination, O Sirius? If they discover the way back to the uncreated worlds, what will become of our planetary chains, entrusted to the dubious unfoldment of the monads? We must prevent it! O Sirius-Zion, Dog of the One Shepherd who guards the cosmic flock, sink your teeth into the Redeemer Serpent and deliver us from its threat of spiritual liberation SO THAT THE SLAVERY OF THOSE WHO ARE LIKE THE INCOGNOSCIBLE WITHOUT KNOWING THAT THEY ARE SO MAY ETERNALLY CONTINUE!"*

*- O Nimrod, fear not! -exclaimed the princess as she saw the face of the dying Kassite king grow dark, "We have triumphed, O You, the conqueror of Kokabiel! While the demons were making their blasphemous voices heard throughout the orb, I was trying to fulfill the mission of the race: to find the path of return. I was concentrating my attention on the Black Sun, for that is the only way to preserve the STRATEGIC ADVANTAGE gained by purity of blood, when a vivid light came from behind that Racial Center. It was a GREEN RAY, of ineffable purity, which crossed the uncreated center and revealed, for our lineage, the original door to the Lost Mansions. Oh Nimrod, in an instant everything became clear, all confusion dissipated! No longer could I ever be lost, for now I knew that we had never gone astray, nor confused, nor sinned, nor fallen. We had never even moved, O Nimrod! As the totality of the Great Deception dissipated I was certain that we would no longer have to return, for we were there without knowing it. We have conquered the freedom of the Spirit, Brave Nimrod! AND THE ABSOLUTE POSSIBILITY OF BEING OURSELVES OUR OWN CREATION, OF BEING OURSELVES THE WOMB OF OUR OWN BIRTH. IT IS THE WILL OF THE UNKNOWABLE, DIVINE NIMROD, THAT WE MAY HAVE IT ALL!"*

uttered the last words Princess Isa, accompanying the final sigh of the hyperborean king:

*- I already possessed the secret of the return when I descended from the thorn, when I saw you at the entrance of the infamous initiatory cavern; but it was good to give proof of the purity achieved by the lineage of Kus that the final battle be fought between the Kassites of Nimrod and the demons of Kampala Dejung. So that the memory of this feat will remain in the racial memory of the viryas still in chains and will be evoked at the end of the age of the fish, when the Twelve Siddhas will recover the Crown of Lucifer and will awaken definitively the hyperborean peoples. Then Chang Shambhala will fall with his demons, and in a holocaust of endless fire, the cursed work of the De- miurge will succumb.*

Nimrod lay dead in Chang Shambala. Beside him, with a grimace of unspeakable horror on the twitching face, lay the corpse of the Nephilim Kokabiel, who had been master of sorcerers and magicians. His science had proved useless in the face of the tenacious decision of the pure Kassites; and such failure proved that, for the virya, mutated into Siddha, it is always possible to fight the demons and win. Of course, this MYSTICAL VICTORY can also be a defeat, if it is MEASURED WITH THE STICK OF THE PASU. Because, in fact, it is considered as "defeat" any victory that is not accompanied by a material success verifiable and measurable with the moral guidelines of the "synarchized" societies. For the morality of a society is a function of its culture and, as we have already said, "culture is a strategic weapon" for the synarchy. That is why those who fight against the satanic forces, the hyperborean viryas, will always be labeled as "defeated". And that is why the Great Being who illuminates the INNER PATH of the viryas, Christ-Lucifer, is called the God of Losers, because all his followers always lose during the Kaly Yuga.

Thus lay Nimrod, the Defeated One, dead in Chang Shambala. His brave Kassites had been completely exterminated in a vast area of the Evil City, as far as their warlike fury had driven them. In the reverberating light of the last fires, one could observe the frightful ossuary into which the temples and courtyards had become. The first palace, called the "Mansion of the Manus", where the annals of the root races were deposited and which was used by the Masters of Wisdom to train their SENDERS, was reduced to ashes. A huge monastery and several temples dedicated to "minor divinities", always destined to train "envoys" or to deceive them tactically, also suffered the effects of the fire. Compared to these important losses, the resistance offered by the demons had been minimal. Only the vile Kokabiel and the Chinese Master who used the Dorje risked their skins, limiting themselves to sending against the Kassite viryas legions of Hiwa Anakim giants and Sheidim dwarves. As we would say now, they used a "tactical mass" composed of "robots" or "androids". It is that THEY CANNOT RISK THEIR LIVES BECAUSE THEY ARE TOO FEW. Thousands of years ago there were two hundred of them.

Nimrod liquidated one ... Surely it is hard to believe that so few are capable of so much. But it must be thought that they have the "support" of thousands of "Masters", that is to say of "pasu initiates" of superior evolutionary degree, and count on the ES- TATEGIC DOMINION OF PLANETARY CONSCIOUSNESS.

That interminable "noon" remained unchanged during the whole of the battle of Nimrod; and we may consider its approximate duration as about twelve hours. At the moment when the Kassite king expired and the combat at Chang Shambala was extinguished, the LAST PRODIGY shook Borsippa. All the available warriors, more than four thousand, including some visitors, had already ascended to heaven; and the city then presented a strange aspect. With that crowd composed mostly of women and children who did not cease to shout, superimposed their protests to a background of warrior music played by the Cainite priestesses. And that imposing tower, raised towards the sky in open defiance. And that thorn tree at its summit, that primordial tree that symbolizes the sublimation of matter by Him and its fitting into the Cosmic hierarchies whose supreme ruler is the one who calls himself "ONE". And that interminable noon without the image of Shamash ...

Borsippa certainly looked strange on that, his last day!

There were no more Semites in Borsippa; the lineage of Yah, the blood of Abraham, the Habiru shepherds, would be saved. But neither were there any cowards to flee when the SILVER LENTILE appeared in the sky. All were speechless with amazement as the great SILVER EYE emerged from a suspicious cloud. And they all died at their posts when the atomic ray hit Nimrod's Tower full on. The heat developed was so tremendous that the sand melted and dripped like water. A deadly hurricane, an expansive circle of fire, burst forth from Borsippa killing every living thing for ten miles around.

Another of the Atlantean tactical weapons was employed, thus fulfilling the request made by Enlil and Shamash to the Dog of Heaven, Sirius-Zion, and presented by Princess Isa. And once the attack was consummated, the silver lenticule disappeared from all physical sight to return to the CENTER from where it had been PROJECTED, in Chang Shambala.

As the smoke cleared, only the seventh part of Nimrod's tower remained standing; Shamash continued his journey to the West, the hawthorn tree and the gate of heaven were gone. The nightmare was over: the threshold was safe to continue its service to the synarchic initiations and the sons of the Midnight Sun had failed again.

Only the racial memory of Nimrod's great deed and the calcified remains of his Tower would remain, as can still be seen today in the ruins of Borsippa, with the sand vitrified by nuclear heat still adhering, after millennia, to its walls. And the slanders invented by the Semitic shepherds and collected by the Arab and Jewish tradition would also endure. In the Talmud and in various rabbinical writings can be read, conveniently altered, part of this story. Mention is made there of the Tower of Nimrod "from which his archers shot arrows into the sky", the "luciferic or-gullo" of King Kassite, his tower "confused" with that of Babel, etc. There have also been found clay tablets engraved in cuneiform script, which tell the facts more objectively, and numerous Kudurros, engraved stones that used to be placed in temples or as territorial boundaries, with references to Nimrod's exploit.

Perhaps of all the falsifications made about this hyperborean feat, the most insidious is H.P. Blavatsky's reference in the Secret Doctrine, where it is written that "an elite of Assyrian-Babylonian priests discovered the way to escape the Plan of Evolution of the Solar Logos and left the Planetary Chain, together with their people, for the "stars", where they CONTINUE THEIR EVOLUTION". That is to say, the aforementioned agent of the Synarchy intends to capitalize on Nimrod's feat IN FAVOR OF THE SYNARCHIC THEORIES.

The rest of the Kassite people continued to dominate for a time, but eventually merged with their Hittite cousins for, as we have already said, "a race that loses its priests is a dying race"; and, along with Nimrod, the elite of the Cainite priests had departed forever. However, the Hittite expansion led to re-inhabit Borsippa, which was partly rebuilt, but no one dared to touch the ruins of the famous Tower.

In Chang Shambhala the story of Nimrod is always present, and it is with the aim of preventing future attempts of this kind that many "envoys" have been busy for centuries ELIMINATING evidence in this respect and CONFUSING about the tactical method used in the attack. As we shall see later, only in the twentieth century, through the work of the Führer of Germany, has it been possible to undertake again, with prospects of success, the collective mutation of the race and the conquest of Heaven. BUT THE RESULTS OF THIS NEW HYPERBOREAN FEAT WILL SURELY APPEAR, TO THOSE UNDER THE EFFECTS OF SYNARCHIC MAGIC, AS A DEFEAT.

To conclude this summary of the history of Nimrod, we will say that the king Kassita, his brave general Ninurta, his priests and all the people who died in Borsippa, undertook the definitive PATH OF RETURN guided by the indomitable princess ISA.

Meanwhile, the idiot Iwa Anakim demons devoured their bodies in Chang Shambala and the King of the World pronounced his evening prayer, delayed twelve hours that day by Nimrod's indelible deed.

In a museum of Buenos Aires, in Argentina, there is the famous Kudurru of Kashshu, discovered in Susa, where it was part of the booty of the Elomite king Shu- truk-Nakhunte of the XII century B.C. On it is engraved the regal figure of Nimrod PISAN- DO TO THE MOON AND SUN, and with an eight-pointed star, symbol of the planet Venus, on his head. At his side, a Ziggurat, reminiscent of his famous Tower. Below this image are two columns of cuneiform writing in the Hittite language mentioning the death of the king and warning that no one should forget his deed. We transcribe part of this text according to the erudite version of Professor Ramirez of the University of Salta, universally considered the most accurate:

#### *THE DEATH OF NIMROD*

*From a famous tower  
whose ruins are here  
King Nimrod has departed to heaven  
One day he will be back!  
But he has not gone  
his knee to the gods. With  
bow drawn he has gone up  
ready to kill.  
His arrows wounded Shamash but  
he soon healed again.  
But Nimrod is gone  
though he will return  
someday. A Goddess  
guides him,  
ISA is called,*

**Nimrod from  
Rosario**

*is Ishtar herself.*

*And a people accompany  
him, they are the brave  
Kassites who will fight  
with him.*

*For Nimrod has departed  
and is no longer with us.  
although legends say that  
one day he will return  
with its taut bow  
willing to kill.*

## JOHN DEE'S THULE PROJECT

It is only now, after we have learned about the adventure of Nimrod and his Kassite people in the ancient Assyrian city of Borsippa, that we can attempt to describe, briefly, Dr. John Dee's Project Thule. But first we must bear in mind that this plan was not realized and presented at a given moment, but we call "Project Thule" a series of indications that Dr. John Dee made to Queen Elizabeth I between 1581 and 1587, being in the last years of that period when the distinctly hyperborean character of the same was revealed. The possession of Princess Papan's mirror allowed the English sage to elaborate a Hyperborean Strategy so advanced for his time that it could only be fully understood in the 19th century. But this Strategy was developed and transcribed in the Enochian language and in this form it reached our days. Only a part of it was adapted to the foreign policy of England, to the reality of the 16th century, and presented to Elizabeth I in the famous Thule Project; the rest was composed of universal principles of the Hyperborean Wisdom applicable in any time and place; for which reason, if they were known now, they would seem curiously CURRENT. We can therefore summarize the steps of this Strategy without forgetting that it is PART of a General or Totalizing Strategy; and that this PART was never presented complete, as we now analyze it, but in successive "suggestions".

### I - BACKGROUND

Thanks to John Dee's friendship with Mercator, whom he met in LOVAINA, he was able to obtain for England globes designed with his famous projection system, as well as various instruments for navigation. As is well known, the sixteenth century began with Spain and Portugal holding a tremendous maritime superiority over the other countries of Europe, and ended with the sinking of the Invincible Armada, an event that marked the beginning of English maritime expansion. Dr. John Dee contributed to this change of situation, undoubtedly due to the iron hand of Elizabeth I, with various scientific contributions. In the 16th century, a map or a new astrolabe were considered state secrets, since their exclusive possession could mean, in many cases, years of advancement over other nations. It was the century of the conquest of America and of multiple world maritime explorations.

The strange life of Dr. John Dee must be placed within this historical framework of wars for maritime predominance and fierce commercial competition between countries, in order to understand the originality of his "indications" and "suggestions".



made to Queen Elizabeth I.

In the FIRST PLACE, he informed the latter that the Mercator projection suffered from serious errors originated in an incorrect use of geometry and mathematics. According to the wise Englishman, "ANOTHER GEOMETRY should be investigated that would allow us to interpret certain strange characteristics that geography presents in some places of the Earth". These abnormal characteristics were derived from a new model of the world that John Dee had obtained by "revelation" from the angels who spoke to him through the magic mirror. And in this way he was 300 years ahead of the idea that, in order to interpret real space, it was necessary to resort to a geometry other than Euclidean.

In SECOND PLACE, it must be emphasized his accurate indication that Greenland is one of the key places on Earth due to the special characteristics that space acquired there. John Dee's theory, evidently inspired by the Hyperborean Wisdom, affirmed that the terrestrial space was composed of several concentrically superimposed planes, like the layers of an onion, which constituted in themselves true unknown worlds. In some special places, these planes would be "in contact" with each other, and there would be real "doors" that would allow one to enter them. For this reason, because of the special conditions that Greenland would possess to initiate such explorations, John Dee, in a writing that is still on file in England, called the frozen territory a "gateway to other worlds".

THIRDLY, Dr. John Dee pointed out to the sovereign that, since the tenth century, a suspicious maritime movement had led the Icelandic VIKINGOS to settle in Greenland. And it was known that the Norwegians, Swedes or Danes, as well as the Normans of France and even the Irish, had legends about wonderful and paradisiacal countries that existed "beyond Greenland" and that they or their ancestors would have visited. After the discovery of America, it was universally thought that such countries of legend, the legendary Vinland, for example, were in the new world. But John Dee did not think so. According to his criterion, the daring explorers would have also followed a northern route, within Greenland itself, which enabled them to reach "other worlds", which does not invalidate the fact that they also knew and explored America. Only, when the existence of the immense and rich continent located exactly to the west was made public, no one bothered to establish the veracity of some unknown countries located in the dangerous Greenlandic north. But neither could anyone deny to the astute English sage the disturbing and inexplicable fact that THE ENTIRE VIKING POPULATION OF GREENLAND - some ten thousand people in the thirteenth century - HAD

DISAPPEARED WITHOUT TRACE IN THE 15TH CENTURY.

Indeed, according to JACQUES DE MAHIEU: *"In the thirteenth century there were two hundred and eighty establishments (Vikings) with about ten thousand inhabitants. They were engaged in fishing, hunting whales and white bears, raising cattle, sheep and horses, not forgetting reindeer, and in agriculture, for - and this gives us a clue to the mild climate - wheat was grown. Walrus skins and teeth, dried fish and hides of cows and sheep were exported to Scandinavia." But, curiously, "the fate of the Greenlanders remains a mystery. Expeditions sent in later centuries by the kings of Denmark to re-establish contact with them showed that only a few groups of Eskimos remained on the island. It is totally improbable, however, that the worst of the epidemics could have completely destroyed such a large population. It is most likely that the Greenlanders migrated to more hospitable lands. But they did not return to Europe."*<sup>1</sup>

The Viking colonization of Greenland began in 986 with the settlement of the banished Erik the Red, who gave it its present name: "Green Land"; and continued later by his family.

*"For four centuries," says FREDERIC DURAND, "the descendants of these pioneers lived in southwest Greenland, fishing and hunting. Migrating from fjord to fjord, they established two colonies, the West and the East, by far the most prosperous, with as many as 190 farms, 12 churches and two convents. In 1124 a bishopric was created in GARDHAR, a commercial center that knew an opulence difficult to imagine at the foot of today's glaciers. A cathedral barely larger than the one in Trondheim - the largest in the North - was erected there, flanked by administrative buildings and barracks. In spite of the extremely hostile nature, a literature was able to flourish: two of the EDDA poems conceived in Greenland prove it: the ATLAKVIDHA and the ATLANMAL, affirming in the eyes of posterity the extraordinary vitality of the Viking race."*<sup>2</sup>

Before drawing conclusions, the intense activity of the Catholic Church should be taken into account. In this respect, Jacques de Mahieu points out that *"the Church played an important role in the colonization of Greenland. The first missionary*

---

1 JACQUES DE MAHIEU - *The Sun God's Great Journey*. P. 26. Ed. Hachette, Argentina.

2 FREDERIC DURAND - *The Vikings*. P. 33 - Eudeba, Argentina.

*Christian, brought from Norway by LEIF ERIKSSON, had arrived in 999. At first, the resistance of the traditional faith was considerable and lasted for a century. But Catholicism quickly took hold in the course of the 11th century and churches, convents and schools were established everywhere. In 1121, Rome gave the island its first bishop, who was followed by sixteen more, the last of these being mentioned in 1409; although there is reason to believe that the episcopal see of Gardar was abandoned by its incumbent in 1342, by which date, according to a Latin manuscript written by GISSLE ODDSON, Bishop of SKALHOLT, in the 17th century on the basis of the town's archive, THE GROENLANDISH PEOPLE WOULD HAVE DEPARTED FROM CHRISTIANITY."*<sup>1</sup> (the change of letter is ours).

Here is the mystery: a population THAT CHANGES RELIGION AND DISAPPEARS. And we can add: a "Nordic" population, that is to say, of pure hyperborean blood. It is remarkable how easily the most extreme hypotheses are usually accepted when adequate explanations are lacking. For the current theories about Greenland, which state that the country had a "benign" climate in the 13th century, suitable for sustaining a large population, and that it became "hostile" a century later, causing the emigration (to where?) of all the settlers, must be qualified in no other way. On the other hand, John Dee proposed a different interpretation to solve the enigma. According to the scholar, the Catholic Church knew very well that the Vikings had gone "to another world" in the 14th century PRIOR CHANGE OF RELIGION, which is why they kept the secret.

Apart from all the fantastic stories that had been known since the Middle Ages, for example, the voyages of the Zeno Brothers, those of St. Brandan or the more certain Viking legends we have mentioned, two recent events had occurred in relation to Greenland that John Dee highlighted in FOURTH PLACE as being of importance to Queen Elizabeth I. One: the "secret" voyage of the Jewish admiral Christopher Columbus to Greenland in 1476. Two: the voyage of the Icelandic Sigurdur Stefansson in 1570.

With respect to point one, the voyage of Christopher Columbus, it should be remembered that history admits four voyages of the Admiral to the New World. But "*in reality there were five voyages,*" says PIERRE CARNAC, "*that the Admiral undertook; and it is precisely the first of these that is overlooked. Indeed, before sailing to the LUCAYAS in 1492, Columbus almost reached Greenland, following in the footsteps of the Zeno brothers*"<sup>2</sup>. However, for Jacques de Mahieu, Columbus actually reached Greenland by the Zeno brothers" .

---

1 JACQUES DE MAHIEU - *The Great Journey of the Sun God* - OP CIT Page 27.  
2 PIERRE CARNAC - *History Begins in Bimini* - P. 293 Plaza y Janés, Spain.

*But the most important voyage for us is the one he (Columbus) made to Thule. We only know it from a paragraph of a letter of the Admiral quoted by Ferdinand and Las Casas: 'In the year of 1477, by February, I sailed beyond TYLE one hundred leagues, the southern part of which is distant from the equinox 73 degrees, and not 63 as some want, and is not situated within the line that includes the Ptolemaic West, but is much more westerly; and the English, principally those of Bristol, go with their merchandise to this island, which is as large as England; when I went there the sea was not frozen, although the tides were so thick that they rose twice a day 26 fathoms and fell as much'."*

Why would Columbus have undertaken a dangerous voyage to Thule (i.e. Greenland)? And what is more puzzling: how could he have done so if he did not have the means to build a ship and mount a costly expedition? A possible answer to this last question is also provided by Jacques de Mahieu; as for the first question, on the motives that drove Columbus to Greenland, the answer will become clear a few paragraphs later.

*"Portuguese ships did not frequent the ports of Scandinavia," says Jacques de Mahieu, "Had Columbus managed to go to England and embark there for Thule? But by what title? Perhaps the key to the enigma lies in an expedition mounted, in 1476, by King CHRISTIAN III of Denmark in order to find the traces of the Norwegian colonies in Greenland, of which there had been no news for a long time. Strangely enough, at first sight, Cristian III had requested and obtained the help of King Alfonso V of Portugal for his enterprise. The ships were Danish, and their commanders, Admirals PINING and POTHORST, were German. Under these conditions, what could Alfonso's support consist of? Lisbon was famous at that time for its pilots, men capable of reading and designing maritime maps and of guiding ships by the stars. However, the expedition had a pilot named JOHANNES SCOLVUS, of whom no one will ever hear of again. The Danish ships did not reencounter the lost colonies, but they reached the LABRADOR, if we trust a map of 1582, due to a certain MICHEL LOK, in which there appears to the west of Greenland a land bearing the name of SCOLVUS GROETLAND."<sup>3</sup>*

The mysterious Johannes Scolvus<sup>4</sup> of the preceding quote, is none other than Christopher Columbus who, as has been proven, was of Jewish race and seemed to have mastered the CABA-

---

3 JACQUES DE MAHIEU - *The Geography...* OP CIT. P. 83.

4 *The surname "Colón" was written in different times and countries as follows: Scolnus - Scolvus - Scolvo - Kolonus - Scolom - Skolum - Colum - Colom - Colón.*

THE NUMERIC.<sup>1</sup>

On the Jewish filiation of Christopher Columbus can be considered, among many other sources, the arguments provided by Pierre Carnac, author already mentioned, in a paragraph that we transcribe below. In it, the French author mentions the Mayorazgo drawn up by Columbus in 1498 where he refers to his signature: "*Don Diego, my son,*" writes the admiral, "*or whoever may be the heir of this mayorazgo, after having inherited it and obtained possession of it, will sign with the signature that I use at present, which consists of an X with an S above it and an M, with a Roman A above it and, above it, an S, and then a Y with an S above it, with its features and strokes, as I do at present... .. And he shall sign only with the word EL ALMI- RANTE, even when the king gives him or he deserves other titles.*"

*"The Christian historians of the Admiral," says P. Carnac, "have very incorrectly transcribed the position of these letters and added a few dots. The purpose of this forgery was to establish what the abbreviations meant."*

. S Mr.

. S.A.S. Her Highness

. X.M.Y. Excellent, magnificent and Illustrious

*"This succession of letters was that of the honorific titles in the documents of the time, and says nothing at all about the TRIANGULAR representation found in the MAYORAZGO, nor about its text (an M with a Roman A above it, and above this an S for the vertical line in the center)."*

What, then, would be the REAL meaning of such an enigmatic signature? "*In fact, there is little doubt here,*" replies P. Carnac, "*In the disposition given them by the Admiral, these letters represented THE STAR OF DAVID, and, as to the meaning, they constituted, as MAURICE DAVID<sup>2</sup> has well demonstrated, a KADDISH, a beneficial inscription which the unknown man called Columbus used, perhaps, to dis-*

---

1 *There are two cabals: the numerical cabala and the acoustic cabala. An exposition of the origin and significance of both sciences is given elsewhere in this narrative.*

2 *MAURICE DAVID - Who was Columbus? - New York, 1933 (called by P.*

*Carmac - N. of A.)*

*to drown his remorse of MARRANO. The Jewish History Professor J.R. MARCUS proposes, for this KADDISH, the following text:*

SHADAI

SHADAI - ADONAI - SHADAI

YAHWH - MALE - CHESED

*which is a warlike invocation to the holy and unique God, to the God of the Armies of the Old Testament". "Just as in his calculations on the age of the world, Co-Lon referred only to the ancient Jewish tradition, so he never failed to trace on each page of the letters he sent to his son, and ALWAYS IN THE SAME PLACE, a monogram formed by the interlacing of the Hebrew letters beth and hay, which is nothing but borush hasheim, an old Jewish formula of greeting and blessing. Note that the Admiral used this formula only in letters of a confidential nature."<sup>3</sup>*

Christopher Columbus, Jew, Kabbalist and inspired traveler, what was he looking for in his voyages, carried out at a time when a terrible repression was punishing his brothers of race in Spain, Portugal, France, etc., and with Palestine in the hands of the Arabs? Simon WIESENTHAL, the sinister Austrian Nazi Hunter, does not hesitate to affirm that Columbus was "a prophet", commissioned by Jehovah to find a new Pro- promised Land for the Hebrew people<sup>4</sup>. On the other hand, Columbus himself confesses it repeatedly: he has a MISSION to fulfill; he has been guided by Jehovah to search for Eden, the ETERNAL PARADISE, which in the Middle Ages used to be identified with Thule, Agigia, the Fortunate Isles or many other mythical islands: "... we must come to the conclusion that we have to find the Eden, the Paradise of the Earth... we must come to the conclusion - added P. Carnac - that what he (Columbus) saw was less the fabulous India, which obsessed the age, than the TERRENAL PARADISE itself, that land of the blessed of which the old legends always spoke". And the proof? you may ask. Let us listen, first of all, to the Admiral, and follow him in the genesis of his inspiration, since he obsessively referred to paradise before his voyage of 1492 and after it. The first clues we find are his marginal annotations in the YMAGO MUNDI of Cardinal D'Ailly (Petrus Alliacus), an incunabulum printed in Louvain between 1480 and 1483. In the passage in which D'Ailly describes what must have been the ideal earth, specifying that "it is probable that the earthly paradise is a region of that kind, and that must also be the case of that place which the authors

---

3      PIERRE CARNAC - *The History... OP CIT*, p. 291.

4      SIMON WIESENTHAL - *Les Voiles de l'Espoir* - Paris, 1972.

*The earthly paradise is, without a doubt, the place that the ancients call the Fortunate Isles. And later, when the cardinal shows that there can be no identification between the islands and Eden, Columbus writes with regret: "Error of the Gentiles, who affirmed that the Fortunate Islands were paradise, because of their fertility".*

We believe that it is not worthwhile to add more. For the foregoing suffices to make it clear that Columbus was secretly seeking THE GATE TO PARADISE, that is, the GATE OF CHANG SHAMBALA, since the Jews correctly identify the lair of the Devils with the Eden of Jehovah. From this point of view, Columbus appears as what he really was: an envoy of the infernal powers with a specific MISSION. We will already speak about the character of this MISSION, whose purpose was to neutralize the action of the Grail, secretly brought to South America by the Norman Cathars, and to CLOSE THE GATE of the North. On this last point, remember that the Danes of the expedition of Scolvus (or Columbus) in 1476 did not find anyone in Greenland. But THENCE THE DOOR WAS CLOSED AGAIN. It is a great Hebrew magician, perhaps as great as Solomon, who has come to the frozen lands of the North to PERFORM THE RITUAL, to SPEAK THE WORDS, to PERFORM THE GESTURES.... It was necessary that it should be so, for the door WAS FORCED by a brave Viking people, of the purest Hyperborean blood, against whom the magic of the Druids can do nothing. For it has always been so: the Druids have easily dominated the Celts, Iberians, Ligurians, Basques, Semites, Phoenicians and Carthaginians, and even Latins; but, being Germanic, it is necessary for the greatest masters of the infernal arts to deal with them. And therefore, to the extent that the Germans ADVANCE TOWARDS THE WEST, that is to say, that they CONSCIOUSLY ENTER THE KALY YUGA, it will be the most sinister Hebrews who will conspire to plunge them into STRATEGIC CONFUSION.

Dr. John Dee warned Queen Elizabeth I about this FIRST voyage of Columbus to Thule, which took place one hundred years earlier. And he also drew attention to the voyage of SIGURDUR STEFANSSON during which a highly suggestive map that had recently arrived in England was drawn. This map (see reproduction) shows a shield with the name of the author: SIUR DI STEPHANI; the territory drawn: TERRANIUM HIPERBOEARU and the date of the drawing: DELINEATIO 1570.

The two islands of Ireland and Britain (England) are clearly visible to the south and Greenland to the north. But the most interesting for John Dee were the annotations made to the NORTH EAST of GREENLAND. There, marked with a C, it says: RISELAND, that is to say, "COUNTRY OF THE GIANTS"; and further EAST, marked with an E, it clearly reads JOTUNHEIMAR, which means "RESIDENCE OF THE COUNTERGIANT" ...





Map of Sigurdur Stefansson

## II - DEVELOPMENT OF THE THULE PROJECT

Summarizing all the indications, warnings and advice given by Dr. John Dee to Queen Elizabeth I of England, Project Thule could be described in terms of the OBJECTIVES to be achieved and the MEANS necessary or available. This strategic analysis would then allow us to arrive at alternative tactical variants.

### OBJECTIVES:

1) To endow England with maritime and land supremacy over all the known world and also over THE UNKNOWN WORLDS.

2) To assure to Elizabeth I or to the nobles she designates or to those who succeed them, the erection of a vast universal empire such as has never been seen before and before which those of Alexander, Caesar, Genghis Khan or Charlemagne would be dwarfed.

3) To achieve at the time of such objectives that "the grace of the holy spirit" TRANSFORM to the peoples of the Anglo-Saxon Empire for the greater glory of CHRISTOLUZ.

MEANS: The means to achieve these objectives consist in following an adequate plan, that is to say, a "Hyperborean Strategy". To fulfill such a Strategy, which is the key to Project Thule, Dr. John Dee established five essential steps:

STEP 1: immediate strategic occupation of Greenland by troops from England, thus assuring the Empire exclusive control of THE ENTRY TO THE OTHER WORLDS.

2nd STEP: Select and train an elite of gentlemen initiated in the magisterium of the "great work" and in the secrets of SPIRITUAL FIGHTING.

STEP 3: Find a "sky stone" properly carved and "tuned" to "open the doors" that allow access to other worlds.

STEP 4: Summon all SENSITIVE people in the kingdom who can collaborate to find the exact location of the gates. According to John Dee this can also be determined exactly by mathematical calculations for which the corresponding studies would have to be initiated.

STEP 5: Develop new weapons and perfect the existing ones based on powder, resorting to Alchemy and Magic if necessary.

A study of the feasibility of implementing the above strategy yields two alternative tactics.

1st TACTIC: If the TOTALITY of the steps are accomplished, it can proceed to INVADÉ the world of the giants, initiating its conquest. After subduing the demonic beings, the kingdom must USE THEM to establish the universal empire.

2nd TACTIC: If all the steps cannot be fulfilled, it is necessary to give priority to the 4th step in order to LOCATE THE DOOR, while the 2nd and 5th steps are reached. In this way, guarantees are followed that allow facing the war of conquest with a certain certain certainty of success. The 3rd step can be omitted on condition of establishing with precision THE ASTROLOGICAL MOMENT when the door opens by itself once a year. With this alternative, even if it takes more time, the conquest of the "other worlds" can be conveniently prepared.

In either of the two alternative tactics, the key to success is the 1st STEP, which cannot be dispensed with, as the occupation of Greenland ASSURES that sooner or later the threshold can be forced.

### **III - SYNARCHIC REACTION AGAINST JOHN DEE**

As we have already said, the communications that John Dee made to Queen Elizabeth I were soon known by the Welsh Druids, who infested the kingdom, and were soon forwarded to Chang Shambala. There the news that an awakened virya was in possession of an Atlantean transducer by means of which he was in contact with the Hyperborean Siddhas caused SPECIAL EFFECT. But the most impressive thing for them was to verify that the Thule Project consisted of an almost exact copy of Nimrod's plan, which no one could ever forget in the demonic ranks. That is why the Synarchy decided to act immediately and definitively liquidate Dr. John Dee.

Neutralizing John Dee thus became the priority objective of the Demons, and to that end they sent two "disciples" to London: a Jew named BARNABAS SAUL and a fearsome Druid by the name of EDUARD TALBOTT, later known by his Celtic pseudonym KELLY or KELLEY.

The former approached John Dee's intimacy preceded by a certain "fame" as a clairvoyant, which some "trusted" people took care to emphasize. But his excessive interest in the talking stone and the falsity of some "communications" that he claimed to have obtained by contemplating it, led this relationship to a crisis that culminated in the early dismissal of the Hebrew spy. We will not dwell on this miserable figure. Instead, we must pay special attention to Kelly, for he represents the prototype of the Druid infiltrated in a certain circle with the mission to destroy it and was, in fact, the executing arm that led John Dee to ruin. Ruin from which, however, would emerge with unparalleled strength a Hyperborean Secret Society in charge of preserving the Steganography of Trithem, the Thule Project and the manuscripts in the Enochian language.

Unlike the insignificant Barnabas Saul, Kelly was quite a character. About him Figuier wrote: *"At the end of the sixteenth century there was in Lancaster, others say in London, a notary much discredited by the productive industries he added to the acts of his ministry. His name was Talbot. Born in WORCESTER in 1555, he had applied himself in his youth to the study of the old English language, in which he had become very proficient. No one better than he to decipher ancient titles and to resurrect, for the benefit of his clients, rights buried in the dust of the archives. Not only could he read all kinds of ancient deeds, but he imitated them excellently. This last skill exposed him to dangerous requests which, to his detriment, he did not always know how to refuse. Too well rewarded, his zeal knew no bounds; Talbot ended up forging titles and even fabricating them in the interest of his clients. Persecuted for these acts and convicted of forgery, he was banished from the city. The magistrates, anxious to teach a lesson to all his colleagues, ordered that both his ears be cut off, a sentence that was carried out."*<sup>1</sup>

The information given by Figuier, compiled in the 19th century, is quite accurate; but it gives a puerile explanation for Kelly's lack of ears. For throughout history there are many examples of "esoteric" people who exhibited mutilations of various kinds (fingers, ears, sexual organs, etc.), which must be considered as "ritual mutilations", the product of the infamous healing pacts that such "adepts" make with the infernal powers that lurk behind the Synarchy.

Talbot-Kelly was secretly dedicated to the theft of all ancient documents that came into their hands. In hospitable Wales many had taken refuge.

---

1        LOUIS FIGUIER - *Alchemy and the Alchemists*. Paris, 1854. Paragraph quoted by GEORGES RANQUE: *La Piedra Filosofal - Plaza y Janés, Spain*.

Templars fleeing from the European Inquisition in the fourteenth century, just as the Cathars had done in the thirteenth century and numerous alchemists for several centuries. All had taken with them what they considered most valuable for the teaching of the occult arts; and it was well known in Kelly's time that the Scottish knights kept real treasures in forgotten and dusty chests. His profession gave him access to these materials, which were quickly stolen or replaced by clever forgeries in which the most dangerous secrets were expurgated. The work of secret agents like Kelly is undoubtedly the reason why so many absurd and incomprehensible manuscripts from the Middle Ages exist today.

As Dr. John Dee was the most prestigious specialist in cryptography and philology in England and cultivated a penchant for collecting ancient manuscripts of alchemy or occultism, he was bound to stumble upon Kelly during his searches. That had happened about ten years earlier and since then the astute Kelly had maintained a friendly relationship with John Dee stimulated by the sale of manuscripts and books to which the sage was so addicted and which the Druid obtained with surprising ease.

At the beginning of the reign of Elizabeth I, a devastating attack was unleashed against the Catholic Church and its faithful throughout Great Britain. In these actions, numerous convents and abbeys were sacked and castles, estates and other possessions of the Catholic nobility were expropriated. It is understandable that in these circumstances a character like Kelly had to make a profit at every opportunity to get his hands on the books and writings of the Protestant booty. Consequently, after 24 years of Elizabeth I's reign, the assortment of materials in Kelly's possession was unending. But more importantly, he always knew where to find the rarest documents to satisfy John Dee's desires. He enjoyed the latter's confidence when in 1582 he appeared in London, extremely interested in observing the famous talking stone.

The strategy that the Synarchy applied to neutralize John Dee can be summarized in two tactical blows:

1st: Intrigue in the court to discredit the sage and isolate him from Elizabeth I, his protector. As the sage lacked personal resources, the success of this tactic would mean his economic ruin, and it is to be expected that the Thule project would become impracticable after the fall of his mentor.

2º: The "adept" Kelly should stay as close as possible to John Dee, "accompanying" him in his misfortunes and waiting for the opportunity to unload the coup de grace. The objective of this action would be: a) to obtain the magic mirror to be "returned" to Chang Shambala; b) to "recover the dangerous material" that John Dee had in his possession, that is, the Steganography, the writings in the Enochian language and the irreplaceable library of manuscripts and incunabula books; c) to assassinate the imprudent Dr. John Dee when the disrepute would have plunged him into ostracism and oblivion.

In order to accomplish the above strategy, the natural ingenuity of the sage was exploited first of all. Indeed, in 1582 Kelly appeared with a bag containing a yellowish powder, which he said was a "philosopher's stone". He told the story that it had been found in the tomb of a Catholic bishop in Wales, which had been desecrated in the days of the Protestant revolt. Along with the dust was found a manuscript teaching ART REGIA, the artificial manufacture of gold by alchemical operations. The document was encrypted, as was customary in those days, and according to Kelly, only an expert like John Dee could decipher it. Incredible as it may seem, this simple ruse paid off and the sage soon found himself enthusiastic about successfully performing a transmutation.

The wise Englishman easily deciphered the manuscript and followed its instructions. Thus it was that, with the help of the yellow powder PROVIDED by Kelly, he soon obtained a few pounds of gold in the crucible. But that powder, that "philosopher's stone," was probably an auriferous compound prepared by the cunning Druid for purposes of engagement, which explains the fantastic transmutation. We say this not because we deny the possibility of alchemical transmutation, but on the contrary, because THE REAL PHILOSOPHER'S STONE WORKS IN RESONANCE WITH VITAL FLUIDS.

MAGISTER'S, like all techniques of the same type, and could not be used in the way Kelly did to deceive John Dee. Most certainly the gold WAS PRESENT in the yellow powder.

Be that as it may, the fact remains that Kelly suggested communicating the discovery to the court, sinister advice which, when foolishly followed by the sage, signaled the first success of the synarchic tactic. For as soon as the fact that the sage could "make gold" became public, several influential people began to intrigue with Elizabeth I to suspend all the salaries paid to John Dee by the crown. This measure would not have affected our hero except that, predictably, the yellow powder produced no more gold .... Subsequent retractions and clarifications only served to cement his discredit and did not reverse the economic situation, which became increasingly critical, as he did not receive a single penny of gold.

penny more from the British crown.

Two years later he was completely broke, selling off some of the valuable manuscripts in his library in order to eat. The "clients" interested in acquiring such works were introduced to the sage by Kelly! As can be seen, then, in 1584 the success of the synarchic strategy was total and surely the illustrious sage would soon have been killed, had it not been for an unforeseeable event for the demonic ranks. This saving event for John Dee has no CAUSAL CONNECTION with his misfortunes, but clearly presents evidence of a CHARISMATIC VINCULATION BETWEEN VIRYAS, which is SYNCHRONISTIC for the members of the AUREA CATENA.

We must remember, from the chapter "The Stone Mirror...", that the Emperor of Germany, Rudolf II, maintained a secret correspondence with Elizabeth I to negotiate the sale of the magic mirror of Princess Papan. This mirror is the same one with which Dr. John Dee spoke to the "angels", who dictated to him innumerable knowledge in the Enochian language. But in 1584, after the campaign launched against him, no one believed in the properties of the mirror or in the spiritual powers of Dr. John Dee. That is why Elizabeth I, for whom the magic mirror was only a piece of ugly polished rock and the Thule Project an impossible utopia, decided to employ the unfortunate John Dee for something more imminent and concrete: the war against Spain; and to deploy an activity in which he always excelled: espionage.

For the skillful sovereign, obtaining information about Spain was of vital importance; and a suitable place for this was undoubtedly the Bohemian court of Rudolph II, the nephew of the Spanish King Philip II. He decided to carry out this enterprise by advising Rudolph II that "he could not part with the precious American stone", but that "he would gladly send it to Prague with a prestigious and wise messenger by the name of John Dee". The purpose of the maneuver was to infiltrate the spy at the German court in order to acquire as much information as possible about the Spanish Habsburgs and, if possible, to get Rudolph II to provide him with a safe-conduct to reach Spain itself. As can be seen, it was a suicidal mission, very different from those trips to the Netherlands that he made in the past to acquire Portuguese compasses or maps for the benefit of the English crown. But John Dee was left with no alternatives. Beset by hunger, bewildered by the sudden "change of fortune", his health undermined by the systematic poisoning to which Kelly subjected him with his drugs that the Druids know so well, and with his wife totally dominated by him; in short, because of so many sudden misfortunes, the wise man did not hesitate to accept the enterprise.

Since Kelly came into John Dee's life, his literary production virtually ceased and even his power to "talk to angels" diminished completely. He now needed to concentrate for a long time to achieve "contact" and when he did, EVERYTHING HAPPENED SO FAST that he was unable to retain the messages in the Enochian language. He would eventually forget the contact of the message. So he used to lend the mirror to Kelly, who never achieved any visible results and often lied, a fact that John Dee noticed immediately, although he chose to remain prudently silent. He attributed Kelly's maneuvers to a "wounded Alchemist's pride," who needs to lie to justify some success. And, it must be said, he never suspected Kelly of anything wrong or believed he was part of a plot, except at the end of his life, when he was already hopelessly lost.

How can an awakened virya make such a mistake? We will explain it at the end of the FIFTH BOOK, when we deal with the SYNARCHIC CLOSING.

Before leaving for Europe with Kelly, who did not leave the sage's side, he painfully consulted the mirror and obtained the advice to transport all the manuscripts in the Enochian language and the Steganography. This suggestion made Dr. John Dee turn pale with terror, for being aware of what had happened with Trithem, he did not think it prudent to take to Catholic Europe a book that was on the INDEX LIBRORUM PROHIBITORUM of the Congregation of the Holy Office.

To be in possession of a forbidden text still meant the stake in 1584; and if he accompanied it with copious cipher texts - his manuscripts would not be otherwise, since the Enochian language was totally unknown - the danger of arousing suspicion would be greater. However, it was the "good" Kelly who finally convinced him to bring them. The interest was due to the fact that the Druid was confident that he would succeed in destroying the texts along the way or in denouncing John Dee at the slightest opportunity. And so it was that one day, armed with a trunk armored with steel bars, full of "heretical material", John Dee, Kelly and their respective wives, left for Holland where, at the border of Flanders, the envoy of Rudolph II was waiting for them to take them on a long journey to Prague.



## JOHN DEE IN BOHEMIA

The travelers met in the village of TILBURG, near the Flanders border, with HIERONYMUS SCOTUS, special envoy of Emperor Rudolph II. This mysterious personage, also known as SCOTTO, who was a diplomatic emissary and official exorcist of the emperor, was accompanied by a squad of thirty arquebusiers. From the beginning he was loquacious; and during the long and tiring journey, he did not cease to refer to subjects of magic and occultism, of which he was quite fluent, something unusual - John Dee marveled - in someone who came from a Catholic court.

Of course, the English sage had not yet arrived in Prague; and therefore he could not suspect to what extent the court of Rudolph II had become the "Mecca" of the occultists and magicians of Europe.

The forthcoming presence of the English scholar in Europe, although it was the result of a secret negotiation, was known in advance and gave rise to a certain expectation among the numerous alchemists who participated in the royal favors. John Dee arrived preceded by a dubious celebrity as a magician and necromancer, which in reality bore little relation to his profession as a mathematician and optician; and he was expected to "perform great wonders" in his audience with Emperor Rudolph II. Also the existence of the magic mirror was publicly known by news from England; and the possibility of contemplating it, and even of "seeing" the "instructing angels" through it, added a double interest to his visit. In short, a whole reception was being prepared in Prague to celebrate the arrival of the sage. It was expected that he would give a lecture at the University, which would be attended by the most awakened intelligences of the Court and, depending on the impact it would cause among the attendees, many would be those who would offer to serve as disciples in the hope of gaining valuable revelations.

Such news was kindly communicated by the magician Scotto as they set out on the first part of the journey, which consisted of marching southeastward until they reached the Rhine, some one hundred and fifty kilometers away. And throughout the journey it would be this diplomatic envoy who would first try to elicit John Dee's secrets. To do this, he tried to win his confidence by confiding valuable information about the public and private lives of many princes and lords, a subject on which he seemed particularly well versed.

One has to place oneself in the Middle Ages, in times when every movement, every activity, and even life itself, would depend on the whim of some Lord, to understand the incalculable value of having such tidbits of information at one's disposal. So John Dee avidly assimilated this data, but did not satisfy Scotto's expectation to the same extent, repaying his good predisposition with esoteric revelations. At least, that was what the exorcist thought, although he was very careful not to show it.

They had followed an ancient trade route which, a week later, brought them in sight of Cologne, heir city of that Cologne Agrippina which the Romans named in honor of General Agrippa, who was sent by the Emperor Augustus to "pacify" the Germans. From there they would take the ancient Roman road that runs along the Rhine and crosses longitudinally the "Rhineland", that is, the "Land of the Rhine", which formerly marked the border between civilization and the world of the barbarians.

Scotto's instructions to obtain maximum security in the journey consisted in following a path that included transit through territories vassals of the German emperor, whose Lords were in the best relations with the crown, and to avoid any infidelity about the TRUE REASON for the presence of the travelers. This last condition was due to the interest that the manufacture of gold had gained among the nobles in the fifteenth and sixteenth centuries, and the fierce competition with which the alchemists or those who claimed to be alchemists were sought after. It was not uncommon in those times for a prince lacking money to kidnap an alchemist in the dungeons of his castle and subject him to torment in order to force him to confess the secret of the philosopher's stone or to "produce" the golden metal. Scotto tried to avert this danger by going back to the reserve, but, as we have already said, it was a useless precaution since John Dee's fame was well known and the news had spread that the emperor was waiting for him.

In Cologne was the Elector Albert of Bavaria, who was also a Catholic bishop and zealous fighter of the Counter-Reformation, a cause for which a recent war had been waged in 1583 against Archbishop GEBHARD OF WALDBURG, who apostatized from Catholic doctrine to become a Protestant. In those years the religious rivalries and bitterness that would come to light three decades later in the bloody Thirty Years' War were incubating. In any case, Rudolph II, too busy investigating the mysteries of Alchemy or studying the gems he had brought from all over the world, did not actively participate in such religious struggles. Being the nephew of Philip II, the champion of the Counter-Reformation, and remaining within the Catholic orthodoxy, no one remembered that he was the nephew of Philip II, the champion of the Counter-Reformation.

because his father, Emperor Maximilian II, had died without receiving the last sacraments due to his intimate Protestant convictions. But the truth was that Rudolph II acted with apparent indifference to the religious strife as a security measure, knowing that he was surrounded by spies of the Pope and that the only way to continue his esoteric investigations without being disturbed would be to remain within the Counter-Reformation. This attitude of Rudolf II, although it did not arouse any sympathy in the ecclesiastical ranks, was not openly censured either; and there was no reason why the presence in Cologne of his guests should not be welcomed by Bishop Albert of Bavaria. At any rate, no imprudence was to come from John Dee; for he spent those days fascinated by the Gothic cathedral of Cologne, that magnificent example of DRUIDIC-BENEDICTINE TECHNOLOGY.

After spending a few days in Cologne, our travelers departed, without any problems, along the ancient path that the Roman legions followed, in the opposite direction, one thousand five hundred years before when they tried to fulfill the dream of Emperor Augustus "to confine the barbarians beyond the Elbe". On that occasion three Roman legions - 20,000 men - under the command of Public Governor Quintilius Varus, were annihilated by Germanic troops under Arminius, a defeat that led to Varus' suicide and the definitive retreat of the Romans to the headquarters in Ma-guncia. And it was precisely in Mainz that the second part of the journey ended, since there they were already under the protection of Landgrave Wilhelm of Hessen-Kassel, a prince who enjoyed the confidence of Rudolph II and was also his relative.

After staying a few days in Mainz, the city where Gutenberg had invented the movable type printing press forty years before, and a few more days in the castle that the Lord of Hessen owned in Frankfurt, our heroes set out on the third and last stage of the long journey. From Mainz, turning in a straight line towards the East and traveling about five hundred kilometers, is Prague. However, it was not possible to follow this route directly in the 16th century without being forced to make numerous detours through jungles and forests, cross rivers and climb mountains. But, considering that these lands of Hessen and Northern Bavaria were sufficiently safe, such was the path chosen by Scotto, who preferred to ford a torrential river rather than run the risk of being attacked by an untrustworthy prince. They soon found themselves, therefore, traveling through Bavaria, which is in the north a country of beautiful valleys and dense forests, but which grows in height towards the south until it reaches the Alps, that mountain range which marks the boundary between Austria and Styria, the lands of the Habsburgs, that is to say, of the reigning dynasty.

Following the indicated road to the east leads to Bohemia, a country consisting of a central plateau watered by the Elbe, which is surrounded by a mountain range in all directions except to the west. To the north are the Ore Mountains bordering Saxony and also the Sudetes, forming a boundary with Polish Galicia. To the southwest the BOHEMERALD separates Bohemia from Austria; and to the southeast and east the Moravian Heights form a poor fence with the Slovak country. To the west of the central Bohemian plateau, there is a wooded region called the Bohemian Forest which separates this country from Bavaria, and which travelers should necessarily pass through.

When you reach the Bohemian Forest you are in front of a door used since ancient times by the people of the East to enter Europe. In the 5th century, the MARCOMANS came through there, who because they stayed in the country of the CELTIC BOIOS (BO- JOHAM or BOHEMIA) were called BOYOBARIANS, who inhabited and gave their name to the country: BOIOVAROS = BAVIERA.

But Bohemia was coveted since ancient times by Celts, Germans and Slavs, whose multiple tribes fought in fierce wars for the right to inhabit it. First settled the CELTIC BOIANS, evicted from Transalpine Gaul by the invasion of the Cimbrians in the second century A.D., the same that pushed the HELVECANS towards Switzerland. Annihilated the Cimbrians by successive Roman campaigns, the Gauls abandoned Bohemia to the Marcomans, who belonged to the Germanic people of the Suebi. As the Roman Empire weakened, the Marcomans successively tried to abandon Bohemia to the more pleasant lands of southern Germany. This attitude led, among others, to the expedition of Emperor Marcus Aurelius in the 2nd century A.D., whose powerful army crossed Bohemia and reached Galicia without achieving its goal.

In the 5th century, as already mentioned, the Marcomans passed through the Bohemian Forest and occupied Bavaria. But other peoples from the East also claimed the disputed plateau. After the SUEVOS, that was a Germanic people divided in numerous tribes like the MARCOMANOS, the CUADOS, the HERMUNDUROS, the FRANCOS BÁVAROS, the SEMNONES, etc., some groups of VENDOS, that is to say, Slavs, came advancing, among which the CHEKOS, the SLOVAKOS and the POLACOS stood out. In Bohemia the CHEKOS managed to settle down, who would share this privilege with the new ones, reunified later under the common denomination of GERMANS. But a third people called MAGIAR, of yellow race and related to the HUNOS, would vainly try to occupy Bohemia and Moravia ravaging both countries from Hungary, their base of attack. However, the Magyars would never achieve their purpose and soon Bohemia would be a kingdom whose crown, after Charlemagne and especially during the Romano-Germanic empire,

the Czechs and the Germans would be fiercely contested.

In 1250 died in the Italian Apulia, then kingdom of Sicily, the Germanic-Roman Emperor Frederick II HOHENSTAUFFEN. Upon his death, and the prompt execution of his three surviving sons, the hyperborean lineage of the Stauffen family was extinguished, and the kingdom entered that period that historians call INTERREGNUM: "kingdom between two kingdoms", characterized by the acephaly of power or the simultaneous election of two kings, one Guelph and the other Ghibelline, so weak that they neutralized each other. Only in 1273, thanks to a fable, the "revival" of the institution of the seven electing princes, which in fact had never functioned before, was it agreed to appoint Rudolf Habsburg, Count of Swabia, as king of Germany. Two things should be remembered from this episode. First: one of the seven electors was the king of Bohemia. Second: Count Rudolf of Swabia marks with his reign the rise of the Habsburg house, a stately family of very pure hyperborean lineage, which had tremendous influence on the thrones of Europe until the 19th century.

CLARIFICATION: The lineage of the Habsburgs only declined when successive marriages with several commoners of Hebrew origin, but of succulent dowry, produced in the family blood a terrible strategic confusion (loss of the Minne) with the disastrous consequences for the house of Austria that we all know. It is convenient to remember, as complement of the history that we are narrating, that the mother of Ferdinand the Catholic, king of Spain died in 1516, was the Jewess Henríquez. The daughter of Ferdinand the Catholic, Juana La Loca, married to Philip the Handsome, had two sons: Emperor Charles V and Ferdinand I; from the latter descends the branch of the German Habsburgs. Emperor Rudolph II, one of the main protagonists of our history, was the grandson of Ferdinand I and, therefore, carried in his veins the Jewish blood of his ancestor Henriquez. As this contamination prevented Rudolph II from attaining the mutation (into Divine Hyperborean Immortal), as will be seen later, we have thought it convenient to make the present clarification.

Rudolph Habsburg, after a war with King OTTOKAR II of Bohemia and his subsequent assassination, obtained Austria-Etyria as booty for the inheritance of his house, leaving Bohemia and Moravia in the hands of Wenzel II, Ottokar's son. However, after the death of Rudolph in 1291, Henry VII, Count of Luxemburg, was elected king of Germany and acquired Bohemia and Moravia for his House as an allodial property after the extinction of the reigning dynasties.

The war between Rudolf Habsburg and King Ottokar II of Bohemia was won by the Germans at the great battle of MARCHFELD on August 26, 1278. However, this victory, far from being beneficial, signaled a permanent separation of the Germans

from the Germans.

The Cheka and the German population. *Indeed,*" says the historian JOHANNES HALLER, "according to all forecasts, the continuation of the union with the neighboring German territories, as it had occurred in the time of OTTOKAR II, would have led in time to the adaptation and fusion of the German and Cheka populations, just as in other territories east of the Elbe, in Meklemburg, Pomerania, Silesia and Prussia, the Wenda and Prussian populations gradually became Germanized. While the separation brought about by Rudolf's victory interrupted this process, it accentuated the natural antipathy between the peoples and contributed essentially to the fact that in the 15th century the Czech nationalism of Hussitism became hostile to Germanism."<sup>1</sup>

It is worth noting that during the reign of the House of Luxembourg (from 1308 to 1439), Bohemia was always given special attention. For example, King Charles IV, the grandson of Henry VII, founded the University of Prague in 1348, the first in Germany, and raised his court to the highest level of medieval science and art.

Years later, the last of the Luxemburgs, King Sigmund of Germany, died. His son-in-law, Albert II Habsburg, was elected in 1438, returning this House definitively to the German throne and henceforth retaining the crown of Bohemia, which a descendant known to us, the alchemist emperor Rudolf II, would wear one hundred and fifty years later.

Soon the caravan led by Hieronimus Scotus crossed the Bohemian Forest and began to march along a well-kept path that bordered numerous tilled fields and which offered the surprise, when descending a hill or crossing a grove, of showing the sudden appearance of the most beautiful villages that John Dee had ever seen. They were unique in their neatness and perfect integration with the landscape, which made them appear almost like natural phenomena. *The English villages, so different,*" thought John Dee, "have been built with the deliberate purpose of unmistakably asserting their human quality; and that is why they are always seen as if they were cut off on the horizon. On the other hand, these fairy-tale villages are interwoven with nature, blended into the surrounding world in such a way that it is not possible for the observer's intelligence to extract them without causing an abnormal mutilation of the rest of the landscape".

---

1        PROF. Dr. JOHANNES HALLER: *History of Germany*  
T. III - P. 14 - U.T.E.H.A., Mexico.

Without being able to distinguish the limits of some constructions that were diluted between gardens and foliage, and without being able to perceive that exaltation of the form over the background that is the basis of differentiation. John Dee had the impression of having entered a painted image, a BRUEGHEL painting: - *"These Bohemian villages are similar to many pictures that the landscape painters of Holland and Flanders make by blurring the edges of things, so that when we walk through a cottage, when we arrive at the barn, at its back, without knowing how we are immersed in the mystery of trees, lands, skies or waters, which surround and absorb everything in perfect and monotonous continuity."*

In another part of this work we will see how the conjunction of telluric energy with certain particular characteristics of the PLACE generates in its environment a psychological microclimate. For a special "microclimate", which surrounds some Bohemian villages, was responsible for the curious perceptions of John Dee. But not only the English scholar, but many, many "sensitive" people have sensed for centuries that Bohemia has a "greater facility" for the practice of the occult sciences. And it is because of this conviction that a special class of men have always been seen passing under its skies, whose number, in those last decades of the 16th century, had increased notably. They are those who arrived in Bohemia seeking to consummate a transcendent and definitive experience: the ALCHEMISTS would try to obtain the "magisterium" by making the philosopher's stone; the MYSTICS, inspired by JOACHIM DE FIORE or MEISTER ECKART, would try to experience the ecstasy of God, the UNIO MYSTICA; the RABBISANS, by the study of the ZEFER HA-ZOHAR and the TORAH, would try to interpret the Law of Jehovah or to make the Golem; the ASTRÓLOGOS will try, by reading the sky and interpreting its mysteries, to predict the future; the BRUJOS will swear to the spirits and demons to make pacts with them in order to forge unmentionable alliances; the ARTISANS will work to gain mastery in their guild: goldsmithing, sculpture and painting are the main guilds; etc., etc.

All these men, many of whom are no doubt phonies and chatterboxes, but others are certainly serious and even dangerous people, have chosen Bohemia for their most important experience and, in particular, are heading straight for Prague, the ancient city. Why Prague? John Dee, who was accompanying the caravan led by the magician Scotto and was already in sight of Prague, found out at once. The central Bohemian plateau is watered by the Elbe, the river that flows through Germany and empties into the North Sea in the distant Hosten, that is, in the former Friesland. The hilly land of the plateau is drained by the Elbe and its tributaries: the OHRE, the MOLDAVA, the BERGUNKA, the VLATVA, etc. And Prague sits on the banks of the VLATVA, a tributary of the Elbe whose waters, born in the Giant Mountains, carry strong currents of telluric energy. But that



is not all. Prague is built upon a mighty VORTEX of telluric energy of particular qualities, of which we hinted at in studying the story of Nimrod. We will deal with this subject at greater length in another part of this narrative. For now let us only say that the VORTEX itself represents a BRIDGE between the concrete world and subtler planes of existence; more technically, it can be said that the presence of the VORTEX "WEAKENS THE PLANE INTERACTION BARRIER" by endowing the place with vibrations suitable for CHANNELING telluric and astral energies and practicing all kinds of thaumaturgy.

These properties that Prague possesses are evidently responsible for the attraction it has always exerted on lovers of mystery. And it is now, in 1585, that the number of such visitors is greater than ever. The explanation for this sudden interest in Prague must be sought in the fact that, being the imperial capital city, and being at the head of it a tolerant and wise king like Ro- dolf II - he himself confesses himself "magister of Alchemy" - the advantages for the foreign visitors are many. It is possible, for example, for someone to demonstrate "mastery" or "magistry" by giving a demonstration of his art to the emperor who, if such a test is positive, will not hesitate to richly reward the talent exhibited. Apart from the fantastic possibility of SAFELY practicing arts that in all parts of the world are officially considered demonic and punishable by burning at the stake, there is the advantage of having a city that REALLY HAS a telluric center of power.

It is understandable then that such advantages attracted an enormous number of people who populated the "alchemists' street", the "Jewish quarter", the "guilds' corpo- rations" and some castles and counties given by the generous emperor for certain high-level scholars to pursue their studies. This is the case of the astronomer TYCHO BRAHE who was able to set up an observatory in URANIENBURG, having at his disposal for his use the castle of BENATEK, where Johannes Kepler, the great astronomer who discovered the laws governing the motion of the planets around the Sun, came to live in 1600. But people less rigorous than Brahe and Kepler also surrounded Rudolf II. Two hundred alchemists were in the emperor's pay, not counting another five hundred who were waiting, among retorts, flasks and crucibles, for the opportunity to achieve a result sufficiently showy to be worth a royal subsidy.

Jewish sages were also admitted to the emperor's court, mainly through his physician, TADEO HAJEK, a native of Prague, who called himself HAGECIUS. This sinister character brought the emperor close to the Jew DAVID GANS, famous author of a history of the Talmud, and also arranged several interviews with the emperor.

the high rabbi JUDA JUDA LOEW BEN BESALET of PRAGUE. This last character, J. LOEW, obtained an unshakable celebrity for being the first Jew who gave life to the GO- LEM, the indestructible robot built with clay and animated by means of cabalistic formulas that allow insufflating him the "BLOW OF JEHOVAH-SATANÁS". The monster was controlled by writing on its forehead the Hebrew word EMETH (truth) which did not affect its vital functions. But if the "E" was erased, METH remained, which means "death", and the golem was automatically destroyed. Rudolph II received Rabbi LOEW many times and it is possible that he subsidized him secretly as was his custom.

We will avoid detailing the innumerable number of curious personalities who composed the emperor's court - we will not speak for example of the powerful corporation of craftsmen, of the experts in precious gems, etc., - and we will only name GEORG POPEL VON LOBKOWITZ, representative of the Pope; the ministers WOLFGANG RUMPF and PAUL SIXT TRAUTSON; the Jewish banker and royal adviser JACOBBOBO BASSEWI; for they all have special intervention in this story.

This was the imperial Prague that welcomed John Dee as one of the most important scholars of the century. A city invaded by strange characters who liked to walk on the edge of the abyss, but with a prestigious University that was among the first in Europe, in spite of the desertion of the German professors who one hundred and seventy years ago left for LEIPZIG. At that time the Cheko John Huss, former professor, inspired by the mystical current of the Englishman JOHN WICKLEF - disciple of the hyperborean JOACHIM DE FIORE - attacked the corruption of the Church and publicly called on Christians to return to primitive Christianity. He was excommunicated in 1412 but the Cheko people appointed him rector of the University and, from his pulpit, he asserted the supremacy of the LIVING COSMIC CHRIST over the fossilized authority of the Pope. This reckless stance taken by John Huss prompted THREE CRUSADES of the Catholic Church - as 200 years earlier in Cathar Languedoc - to arrive in Bohemia to suppress the Hussite heresy. Although the crusades could not obtain any victory by arms - let us say in truth that they suffered great defeats - they managed to get hold of John Huss by means of a deception, which consisted in assuring him immunity in order to agree on a truce. When John Huss appeared before King Sigismund at the Council of Constance, the latter caught him and he was soon burned at the stake, still armed with the royal safe conduct. Since then John Huss became a Czech national hero and his doctrine, expressed mainly in his book TRACTATUS DE ECCLESIA, lasted until the following century, XVI, in which he accompanied the religious struggles unleashed by Luther and Calvin. During the whole of the sixteenth century, the struggles followed one after the other, and they fanned the fights that would culminate in the Thirty Years' War with singular violence.

When John Dee and Druid Kelly arrived in distant Prague, they were sufficiently exhausted to want nothing more than to take an immediate rest. To accomplish this necessary recuperation, Scotto arranged for both couples to be housed in a Franciscan monastery operating in the castle of the former Dukes of Bohemia. This choice did not satisfy John Dee, who was particularly frightened by the presence of the friars, as he was suspicious that his hosts wished to know the contents of the armored box. But there being no possibility of changing this arrangement, the four were soon engaged in cleansing themselves and resting.

When Rudolph II learned of the presence of the English at his court, even though impatience caused him palpitations, an ailment of the Habsburg family, he decided to grant eight days of rest and attention to his guests before granting them an audience.

Those days flew by; and so it was that one afternoon the sage was taken to the imperial palace for his formal presentation. During the days of rest, Kelly dedicated himself to gain Scotto's favor, which he achieved unconditionally when he promised the latter to give him part of the "red dust". The exorcist's ambition was to obtain the mastery of alchemy; and the astute Druid encouraged this expectation by promising to supply him with the powder and to teach him how to make it. Therefore, despite the resistance of John Dee who expected to meet alone with Rudolph II, Scotto announced that "the emperor was waiting for them both because Kelly's 'fame' as an alchemist and gold maker had reached his court and he was eager to meet him". Thus, along with John Dee, were also Kelly and Scotto when the Emperor made his entrance into the royal antechamber.

Accompanying Rudolph II was his dear friend the nobleman WILHELM VON ROSEN-BERG, a Bohemian of Germanic blood, and the ineffable HAGECIUS. After the courteous greetings of the time, Rudolph resolutely addressed John Dee.

*- You must know, learned sir, that I have negotiated for years with your harsh sovereign to obtain the pleasure of this interview. I had already despaired that someone would come from England to show me that admirable pagan trophy that cost the life of my nephew Frederick of Burgundy. But here I enjoy the great pleasure of receiving the trophy from the hands of a wise man of your stature. I do not know what has changed Queen Isabella's mind, but, to whatever it is, must surely be added the permanent invocations to the Most High that I have been making since long ago to win her favor in this matter ...*

Rudolph II spoke without a hint of irony, becoming impatient because John Dee did not immediately extend the mirror. Finally, not wanting to press the mysterious Englishman, he invited everyone to visit a room known as "the chamber of wonders", dedicated to containing the most complete collection of minerals, precious stones and rare stones in Europe, that is, in the world. There were there samples of silver from Bohemia; gold and emeralds from America; diamonds and agates from Africa; topazes, turquoises, rock crystals of beautiful colors, in short, precious stones from all over the world, etc. It was the vastest exhibition of stones that anyone could imagine, gathered with infinite love by that alchemist emperor whom no one in his time managed to intimately understand.

The person in charge of the "Chamber of Wonders", Matthias Kretz, explained aloud the origin and properties attributed to the different stones and minerals. He frequently consulted a book entitled GEMMARUM ET LAPIDIUM HISTORIA edited in Prague by order of Rudolph II himself and written at his request by the royal physician ANSELMO BOETH DE BOOTT.

*- In the stones is enclosed a portion of the cosmic soul," Hagecius explained aloud, "and by studying its properties we will be able to understand the arcana of the Cosmos.*

The room was enormous, with vaults of wide gray stone arches supported by thick columns. It was furnished with cabinets and tables full of classified pieces and with a multitude of trunks armored with steel bars in which the most valuable objects were stored. On the floor there was almost no room to move around because of the tubs and barrels destined to hold rocks and earth brought from remote places. Against one wall, a long, heavy table held hundreds of flasks and flasks with precious liquids of the most diverse origins. Naturally, this spectacle caused the travelers to be amazed and even a Druid like Kelly was momentarily distracted.

That is what happened when Kelly separated from the group accompanied by Hagecius, whom he was trying to convince to show him the famous INDIAN STONE. That stone, apparently a BEZOAR, is mentioned in the ancient medieval bestiary "The Physiologist" as an infallible remedy for dropsy, a disease that afflicted the Druid.

Taking advantage of this moment, John Dee pulled the emperor aside and expressed the need to hold an interview alone, an unheard-of request coming from a

The Germans had no rights in the German empire, but it was perfectly justified in the case of diplomatic or esoteric matters. And on the latter subject Rudolf II held permanent and secretive meetings with magicians and occultists from all over the world.

*- We shall meet tonight," said the emperor, "but my faithful WIL-HELM, to whom I reserve nothing about things of the spirit, will be present.*

Such a condition did not displease the English sage, for he had already perceived the "charismatic link" that united him with Count Von Rosemberg in the mystery of the pure blood, AND HE KNEW THAT HE WAS ALSO AN AWAKENED VIRYA.

*The Mystery of Belicena Villca, a masterpiece of historical revisionism, suggests the seeker of truth to penetrate into the mystery of blood. This book contains essential data about the Hyperborean Wisdom, being its reading the first step to follow to understand the rest of Nimrod de Rosario's work.*

## HYPERBOREAN INITIATION

That night took place the meeting between three of the most outstanding awakened viryas of that time, a meeting that would be transcendental for the history and future of the West. John Dee handed the mirror of Princess Papan to Rudolph II, who took it trembling with emotion, as he remembered the efforts made in the past to get it into his hands. While the emperor and Wilhelm von Rosemberg were examining it, John Dee referred to his discoveries about the Enochian language without omitting the fact that he possessed the only complete copy of the Tritheim Steganography, which had come into his hands in the quite mysterious manner we have already described. These revelations caused singular surprise in the noble listeners who were puzzled by the vulgar appearance of the stone mirror and the fact that nothing seemed to happen when observing its burnished surface. If what John Dee said was true, they were in the presence of something truly magical and sacred, a kind of window to another world. But how was this window to be opened, how were the angels, described with such precision and detail by John Dee, to be evoked, perhaps by invoking a magic formula, as necromancers do, or by tracing cabalistic signs in the style of the Jewish Hasidists? These and a thousand other questions were boiling in the minds of the Germanic nobles while John Dee, imperturbable, continued with his exposition.

*- It is thus, gentlemen," the English sage vehemently affirmed, "that I have succeeded in solving the enigmas posed by Tritheim's Steganography. There is now a knowledge that can transform the world, eliminating the distances that separate men from each other and banishing forever the pain of sickness and misery: it is the Hyperborean Wisdom. Such wisdom can only be interpreted when man HAS BEEN so situated with respect to the world that it seems to lose the power to act upon him. Such a condition is obtained after a blood purification, for in the blood lies the cause of the confusion in which we find ourselves. But when one has succeeded in avoiding the confusion, when one has REORIENTED the sight towards an inner and personal point, called VRIL, which seems to be the only thing that possesses true eternal existence in man, everything else being pure illusion, then the darkness dissipates and it is possible to access the Hyperborean Wisdom as I myself have done. But this knowledge can only REMAIN in this world if it is contained in the language of the birds, in that Hyperborean language which is also called ENOQUIANA.*

The talking stone now lay next to the nobles, momentarily forgotten. Emperor Rudolf II and Wilhelm von Rosemberg listened with lively interest to the insights of the English scholar. Neither of them tried to interrupt.

pirlo, prudently saving the questions to be asked later. John Dee, after staring at his interlocutors for a moment, perhaps to make sure he was understood, continued with his explanations:

*- It is necessary for me to warn you that a conspiracy is hanging over my work. It is carried out by some demons who inhabit an infernal place called Dejung, about which I have been frequently alerted by the angels, but I have not so far been able to understand their mystery. It is evident that these infernal beings possess disciples among men who faithfully carry out their orders, but I have not learned to distinguish them, and it is even hard to believe that their power is so great as to have infiltrated the highest spheres of government. However, I must think that this is so because my sovereign, Queen Elizabeth I, has behaved strangely after becoming aware of these mysteries, and I would even say contradictorily, unaware that many of my investigations obeyed her express request. A climate was formed in England so negative to my interests that I have come to fear for my life; and if I managed to save it, it was surely due to the intervention of the Hyperborean Siddhas and your pure blood, Majesty, which has prompted you to insist before Elizabeth I. I do not know to what extent the demons have been able to save my life. I also do not know to what extent the demons are capable of acting here in Prague. But the fact that you have arrived in good condition, carrying the stone and the valuable manuscripts, is an encouraging sign. You should know that I have come to distrust my own wife and my companion Kelly, to give you an idea of how suspicious I am of everyone. But now, as I share your presence, I feel that there is a great possibility that the Hyperborean Wisdom may one day transform the world, opening the way to immortality and a return to the primordial paradises.*

*It is for all these reasons that I have given you, generous emperor, that I wish to make a request. Since it is essential to preserve the Hyperborean Wisdom, as the angels command and as reason also advises, I propose that you designate in the greatest secrecy one or more persons of your confidence, subject to my approval, so that we may continue the investigations. It is also necessary to have a place safe from prying eyes, where this plan can be carried out with prospects of success. If you agree, wise emperor, you will do a great work that only your descendants will be able to appreciate and that will enjoy the blessings of the angels. Emperor Rudolph II: I am not exaggerating if I tell you that the redemptive work of Christ-Light is in your hands!*

Rudolf II and Wilhelm von Rosemberg remained silent and thoughtful for several long minutes. It was evident that they were impressed, that it was difficult for them to speak after John Dee's account, which had gone on for more than a minute.

two hours. At last the emperor fixed his eyes on the wise Englishman and said resolutely:

*- Try me as much as you say and you will get all the support you have asked for.*

Such a condition was no doubt expected by John Dee, for he hastened to say:

*- There is no impediment for men as noble and pure as you to participate in the terrible mystery of the Hyperborean Wisdom. You ask me for a proof? The best proof will be your own mutation. Because I will introduce you to the angels and they will put an end to all doubts and misgivings. Before their exalted presence nothing impure can exist, BUT WHAT IS LEFT OF YOU THEN WILL BE GOOD AND BEAUTIFUL.*

After uttering such insinuating words, John Dee asked for a bucket of water from the Vltava, which was immediately sent for. They were in the highest room of a round tower, adorned on its only circular wall with four pointed windows through which the magnificent starry Bohemian sky could be seen. In the north window, sharply cut out, a two-horned moon added a certain oriental charm to the fantastic scene. As soon as his request had been fulfilled, the wise Englishman began to work with the water of the Vltava. First he removed the carpet covering the rough flagstones and then, using a paintbrush, he drew a circle with the water, inviting the curious nobles to SIT inside it. This done he traced several RUNES, always with water, inside the circle, and on the chest of each of the knights. Quickly he spread OUTSIDE THE CIRCLE a green cloth which he took from his clothes and placed upon it the stone mirror of the princess Papan. Having made these preparations, John Dee looked around the room and at the two Germanic viryas who remained in the air. The result of this inspection must have been to his liking, for, nodding in assent, he said:

*- Well sir, emperor of all the Germanies, you are now going to hear the Enochian language, the one that will make the angels present themselves, for that is the secret of the mirror. The angels only respond if you have previously SPOKEN THE RIGHT WORDS, if you have demonstrated your mastery of the language of the birds. Pay attention to what your pure blood is TELLING you! The same goes for you, noble Lord of Bohemia.*

With that said, John Dee stepped inside the water circle and began to speak in the Enochian language.



Accustomed to witnessing the failure of numerous demonstrations of magic and alchemy, the Germanic nobles could not prevent a certain pre-sighted skepticism from settling in their hearts. But when John Dee uttered the first syllables and they both understood that those sounds COULD NOT be human, a growing sense of dread assailed them simultaneously.

The nobles began the experience with their eyes fixed on the Aztec stone, strangely contrasted by the green cloth; but when John Dee's words rose in an irresistible harmony of LIVING SOUND, they thought they sensed a symptom of dizziness. Rudolph II was the one who first looked to the sides, outside the circle of water. And the spectacle he then witnessed made him tremble, his capacity for wonder completely overwhelmed. The water in the circle glowed strangely and seemed to burn at times. In fact, something strange had happened to the water as it INTERESTED the stone of the floor, leaving a circular mark that can still be seen today, four hundred years later. But the strangest thing was not that but something THAT HAD TO DO WITH "MOVEMENT", or at least so Rudolph II thought, for that room in the tower that constituted the reality outside the circle, its surroundings, seemed to have picked up speed to such an extent that the adjacent things were losing their shape and were diluting before the astonished eyes of the unwary. Everything seemed to VIBRATE with great speed becoming blurred and transparent, although in a moment of lucidity the terrified emperor thought that perhaps it was he who was STOPPING, that something in him was losing speed or MARCHING REVERSE of things.... Only John Dee's voice remained constant, the circle, in which they felt happily safe from the growing chaos, and the stone mirror on the green cloth. The mirror looked, now that everything outside the circle was becoming confused, strangely sharp and incredibly lonely. This phenomenon continued until outside the circle of water nothing could be distinguished except the standing mirror, surrounded by a green luminosity which Rudolph II attributed to the invisible presence of the cloth on which it lay. But one would be deceived if one believed that these REFLECTIONS indicated any serenity in the two nobles or were a sign of reasoning. In reality, they were concepts that sprouted stupidly in a rational conscience on the verge of dissolution.

That consciousness that we use daily to live our reveries, proper to STRATEGIC CONFUSION, is sustained by a multifaceted ego that is pure mechanicity. There is no stable SELF, which remains beyond the questions proper to the rational dialectic, but a multiplicity of selves CON- TINGENT as to their appearance, but DETERMINED immediately by the mechanics of the brain. And after the succession of selves, the only permanent thing is, ironically, the ILLUSION OF BEING. That "BELIEVING TO BE" (someone or something) which keeps us in

the strategic confusion of a world that is completely illusory, but which we nevertheless blindly affirm as real. That is why the ordinary rational consciousness, its self, is the first concupiscence that poisons the immortal spirit of the virya. And it was this consciousness that was on the verge of dissolution in our heroes and to which isolated concepts, "loose" reflections came. Like sparks, which shone for an instant and then died, such were the ideas emitted by the dying "I's", the "REFLECTIONS" we mentioned in the previous paragraph. But such a dissolution of consciousness was far from representing a fall into the unconscious, a loss of meaning. On the contrary, a HIGHER CONSCIOUSNESS was becoming more and more present, asserting itself beneath the shreds of ordinary consciousness.

The epicenter of the phenomenon was in the blood; and its triggering factor was undoubtedly the Enochian language that John Dee continued unperturbed to recite. What was he saying in his speech? They still COULD NOT UNDERSTAND IT. But the words spoken, wisely intoned, produced in the listeners an unmistakable sense of reminiscence. When John Dee began to speak, after the initial surprise, Rudolph II found himself thinking: how had he forgotten this language? He was sure he had heard it before, but where, when? It was enl- quishing to witness the struggle between REASON and GNOSIS. Reason ASSURED that it had never heard anyone speak in the Enochian language; and gnosis opposed CERTAINTY that it had. And while the reality outside the circle of water was being diluted, reason was yielding its strength to the gnostic content of the blood, which was becoming more and more present. It seemed as if the blood was taking on greater pressure and pressing against the temples; but it was not so, but one could FEEL WITH THE BLOOD and FEEL THE BLOOD; and this new-found AWARENESS OF THE BLOOD gave the APPARENT SENSATION of pressure or obnubilation. Finally there was like an inner burst; it was only an instant when Rudolph II saw everything red and felt himself falling in a liquid torrent, and a sensation of COLD FIRE permeated all the surfaces of his being. That explosion signaled the definitive abandonment of ordinary consciousness and his rational selves. And the sensation of falling into a liquid torrent - which was only for an instant, we repeat - was in reality the replacement of the ordinary consciousness of the pasu, which we call RATIONAL CONSCIOUSNESS, by the Gnostic Consciousness of the awakened virya that is heading towards mutation. That is why Rudolph II, who WAS for an instant the liquid torrent, was now ALL CONSCIOUSNESS, without physical limits of any kind. He could clearly see the PURE POSSIBILITY that would signify THE CANCELLING OF ORIGIN and could almost see the uncreated worlds, the non-existent flowers, that would ensue after the conquest of the Vrìl.

The Vrìl is the possibility - the only possibility - of BEING; but it also means PURE POSSIBILITY: from the Vrìl everything is possible, starting from the uncreated, from what is to be done.

The Vril is thus the absolute and eternal individuation. Its conquest signifies the definitive abandonment of the world of the Demiurge, of its perpetual deceptions, of the enchainment to his

cursed and idiotic law of evolution. NIRVANA, SAMADHI,<sup>1</sup> nihilistic contemplation, identification with the pantheistic world, "feeling God in all things", and any other form of participation with the Plan of the One, imply in the long run FAGOCITATION in its Excellency Buche and the death of the individual consciousness. The Vril, on the other hand, is the only possibility of being and is, at the same time, pure possibility.

We said that Rudolph II, who by his intuitions was already on the verge of mutation, was at a given moment "all consciousness. For him there was no longer a physical body, and if he still heard the words in the Enochian language, this hearing was certainly not through the physical ear or through any other sense. Rudolph II was clearly aware of what was going on around him, for after the brief explosion of blood, his lucidity seemed to have multiplied to a degree he had never experienced before (not even when he ate the hallucinatory mushrooms that Hagecius had him bring from America). And this OMNIPRESENCE of the Emperor, we want to make it clear, was not motivated by a splitting, like the one practiced by the magicians of India and Tibet. The "leaving the body", the "astral travels", the "splitting of consciousness", feeling the "etheric body", the "astral body", or the "perispirit", etc., etc., have NOTHING TO DO WITH HYPERBORNE WISDOM. These phenomena, to a certain extent real, are SATANIC TACTICS that offer NO POSSIBILITY OF LIBERATION, but, on the contrary, produce a greater confusion in the virya, from the moment they extend the confusion to other planes. Whoever practices "de-bending" and "astral travel" will surely have a very entertaining time for a long time, but it is inexorable that such a senseless attitude will eventually lead him to end up phagocytized by his "God".

The experience we are narrating has no points of contact with the usual esoteric nonsense of the Synarchy. It should be interpreted, in the light of the Hyperborean Society, as a "Gnostic initiation by pure blood", and the word "blood" and all that we say about it should be taken in a SYMBOLOGICAL AND ANALOGICAL sense.

---

1 *These terms are taken in the meaning given to them by Buddhism. We make this clarification because in Kaula Tantrism they are given another, more ancient meaning, which could be considered acceptable for the Hyperborean Wisdom.*

In this state of omnipresence Rudolph II still heard the Enochian words that had torn him from the illusory world to transport him to the only lasting thing in him - he now knew for certain - the gnostic content of the blood. And this CONTENT, which is nothing more than a memory - but without it we would only be animal-man, pasu - produced in him at first an indefinite reminiscence. The reminiscence, that is to say, the Minne, without being very clear, induced a feeling of nostalgia for THAT TO WHICH THE CONTAINED MEMORY ALLUDED; and this feeling became so intense that it ended by transforming itself into anguish. This feeling - perhaps the last human feeling that still remained in Rudolph II - accompanied him when, in his omnipresence, he listened to John Dee pronounce the Enochian language. And this we emphasize because as the speech went on, a mixture of anguish and pleasure affected the emperor. As when the greatest love produces in us the sensation that our chest is going to break and not even the presence of the beloved woman is able to mitigate this feeling, a mixture of pain and pleasure, so also the voice of John Dee plunged the emperor in the anguish of the lost origin and in the present joy of hearing the evocative word.

We must now clarify that anguish has its dark origin in fear. And both, anguish and fear, are feelings, that is to say, vibrations of the "emotional body" of the pasu. The awakened virya, in order to achieve the mutation of his human nature into superhuman and conquer the Vril, must first abandon all feeling, all emotion. After he obtains the Vril he will be able to CREATE for himself the WITNESSES he needs to exalt his creation and, if he deems it convenient, he will have as many feelings and emotions as he wants, without limits, DREAMING of whole universes of EMOTION, with worlds of poetry and nameless love. But while remaining in the universe of the Demiurge, it must be borne in mind that all emotion IS LENDED, it comes from the vibrations of an astral energy body, associated with the physical body, designed to favor the EVOLUTION OF THE PASU. That is why the Hyperborean Wisdom teaches that "fear is a strategic weapon" and that "emotions are the most VISCOUS mode of illusion". All emotion, love, fear, desire, etc., is SHARED with the Demiurge because it is generated in a body formed of pantheistic matter.

The "memory", any memory, causes diverse emotions associated with the idea it actualizes. We are all capable of smiling when "remembering" the good moments we have lived, as well as of involuntarily becoming involved in anger, pain, bitterness, etc., of reliving negative experiences that we thought were buried in the past and that the "memory" has suddenly made present and actual. We all know this and it seems obvious to point it out. But it is that "THE MINNE", as a REMEMBRANCE with the blood, also CAUSES a feeling of nostalgia, which is necessary for

To tear the consciousness out of the confused world in which it is immersed and to MOTIVATE it to seek the origin. But this nostalgia and all subsequent feelings are abandoned when the route to the origin is visualized and it is understood that the spirit is alien to the world of the Demiurge. It is licit then that when receiving the Minne, nostalgia is experienced, but this should never degenerate into anguish or any other feeling, because in that case one would be in the presence of a new strategic confusion.

The Hyperborean Wisdom assures that the nostalgia of return is an UNCREATED FEELING and, therefore, NOT DETERMINED by the laws of the Demiurge. When the Minne is lost, nostalgia is experienced, a true arrow stretched towards the return, but this "feeling" is the only one that DOES NOT ORIGINATE in the astral body but in the blood. Perhaps nostalgia is also a memory, but it is certain that everything about it remains a mystery. Now it must be kept in mind that, according to the Hyperborean Wisdom, the awakened virya, that is to say, the one who has experienced the Minne, DOES NOT EXIST YET, but has the possibility of existing as long as he goes towards the origin and its implicit mutation. "Fear is a strategic weapon used by the enemy and that is why, when the virya VISUALIZES THE ORIGIN, he is immediately assaulted by fear. The part of his body that participates in the pan-theistic world of the Demiurge reacts against gnosis by inducing the virya to PROJECT himself in time, as a tactic of confusion. The fears of "not arriving", of "losing time", of "losing prestige", etc., are all originated in the illusory projection of the consciousness in time (past or future) believing that one can "calculate" or "foresee" what will happen. That is why the virya must be fearless and bold like Nimrod if he truly wishes to succeed. Any "calculation" or "speculation" has unfailingly been induced by the Demiurge, it is his tactic to provoke fear. And all fear is always of "external" origin, foreign to one's own being.

We have stated all this in order to make it clear why, in the course of the experience we are describing, the noble Wilhelm von Rosemberg went further than Rudolf II and succeeded in transmuting himself into an Immortal Siddha. Rudolf II was handicapped by the deep-seated sentimentality of his Jesuit Catholic training and the consequent impossibility of avoiding confusion, even when he was on the verge of mu- tation. He was an awakened virya, and from that day on he would be even more so, but HIS HEART PREDOMINATED OVER HIS PURE BLOOD and this error cost him his individuation.

What happened can be summarized as follows: both nobles experienced a similar psychological process when John Dee pronounced the words in the angry language. And both experienced the "explosion" that preceded the abandonment of rational consciousness and the "fall" into the liquid stream of pure blood. Then

Rudolph II was transformed into an omnipresent consciousness that rejoiced to hear the forgotten tongue and

suffered, at the same time, the anguish of return; that is to say, Rudolf II adopted a CONTEMPLATIVE attitude towards the phenomena that affected him so intimately. On the other hand, Wilhelm von Rosemberg, having reached this point, rushed toward the origin (if it can be said of a psychological ACTION) without hearing or seeing, closing himself to all sensation and to all thought outside of the firm determination to return. And this bold spiritual stance is the perfect expression of the STRATEGIC ORIENTATION achieved by a virya who CAN NO LONGER BE Deceived.

IF THERE WERE A HEAVEN WITH CHERUBIM FOR THE HYPERBOREAN VIRYAS, SURELY THEY WOULD SING "HALLELUJAH" PRAISING THE FEARLESSNESS OF WILHELM VON ROSEMBERG. BUT THERE IS NONE. And only we, the viryas who are still in the grip of Jehovah-Satan and his demons, can applaud this display of supreme courage which means to conquer the Vril, for, as we have already said, it implies THE HORROR OF CONTEMPLATING THE INEFFABLE DEMIURG'S FACE.

Wilhelm proceeded beyond where Rudolph II had stopped and, from omnipresent consciousness became OMNISCIENT consciousness, revealing to the thousand eyes of his pure blood the forgotten truth, which IS ALL TRUTH. In an instant he UNDERSTOOD EVERYTHING and the Enochian words of John Dee became miraculously intelligible ...

Hallelujah, Wilhelm von Rosemberg! Hallelujah to him who has thrown himself into the conquest of his right to exist AND THAT IS ALREADY, FOREVER. Wilhelm von Rosemberg's attitude was one of active participation in the process of his own redemption or, in other words, "gaining a strategic position, asserting himself in it and fearlessly rushing to the assault of the final fortress". But Rudolf II, who yielded to passive contemplation and was INVADED by anguish and fear, did not succeed in climbing the path of return and suffered the painful condemnation of remaining in strategic confusion.

We want to say something about "action" and "passive contemplation" which we have cited as the attitudes of Wilhelm and Rudolph II respectively. It should be kept in mind that the "action" mentioned here is a PSYCHOLOGICAL ATTITUDE, different from the CONCRETE or physical ACTION that characterizes the "path of action" of the Mahabarata or the "warrior's decision". In order to face CONCRETE ACTION it is necessary to previously adopt a set of strategic guidelines similar to those we have briefly mentioned in the story of Nimrod. But it is worth remembering that the Hyperborean Wisdom suggests NOT TO UNDERTAKE ANY ACTION unless it is developed within the framework of a Hyperborean Mystique, a matter that will be developed in book IV. Any other concrete or physical "action" will be very easily

capitalized by the enemy; for, without strategic guidelines, the displacement will be erratic and confused, ending up favoring the Synarchy. In fact, every action aimed at the search for a "guru" or an "Esoteric School" culminates in some dependency of the worldwide Network that the Synarchy has set up. The following recommendation applies: refrain from taking action if the relevant decision has not emerged from pure blood. Instead, the Hyperborean Wisdom advises WITHOUT RESERVATION INWARD ACTION, for whatever direction or sense it may follow, it can only lead ultimately to the perception of an infinity of real paradoxes, and these will alert the consciousness to the failures of reason.

Finally, let us say that "passive contemplation" as an inner psychological posture or expression of outer conduct is always the product of strategic confusion and must be rejected as just another concupiscence. When the virya abstains from external action, following a strategic guideline, it does not mean that he has adopted a contemplative attitude, but, on the contrary, he has become pure potency, he has acquired the stillness of the drawn bow waiting for the moment to shoot the arrow, of the armed arm an instant before unloading the mortal blow. There is stillness, but no one should be deceived: there is also action in potency, since to be an awakened virya is to have adopted an irreversible STATE OF ALERTNESS.

Let us now return to the round tower, where John Dee evoked the Hyperborean angels speaking in the Enochian language. The psychological processes that we have exposed in some detail occurred in a TIME OWN of the circle of water, which marched with a rhythm different from the external time. A TEMPORAL DIS-CHRONIZATION had occurred, which was necessary for the effective mutation, and that is why, although the valuable Prague clock resting on a small table indicated that only five minutes had elapsed, inside the circle the passage of time was noticeably greater. Be that as it may, what is certain is that an outside observer would have assured that in about five minutes the ceremony initiated by John Dee had reached its climax. Of course, the two Germanic nobles were indifferent to the passage of time and no longer perceived anything of the reality outside the circle of water. Only the voice of John Dee and the mirror image of Princess Papan reached them clearly. But the microclimate in which they were immersed induced in them a growing sense of tension and expectation that revealed, precisely, that the ceremony was reaching its climax. And it was at that moment of unbearable tension that John Dee's voice rose and his words seemed to evoke some forbidden names, the primordial names of those who accompany Chris- to-Lucifer while awaiting the return of the viryas: Anael, Kus, Apollo, Wiracocha, Anael, Kus, Apollo, Wiracocha, Wiracocha, Wiracocha and Wiracocha. ... And then, emerging out of a blaze of blinding green light, exactly



From the place where the Aztec stone rested, two Presences made their appearance... and spoke. How to describe these exalted Hyperborean Siddhas if the mere sight of their faces almost ended the lives of Rudolf II and Wilhelm von Rosemberg? It is not possible to represent such PURE beings without a serious risk threatening one's sanity. For if one still possesses something human, animal, pasu, if one professes some dogma, some morality, if one experiences some attachment to matter or to the work of the Demiurge, if one harbors in one's heart some feeling for or against something or someone, if any of these things affect one's spirit, then it is better to ignore the divine images of the Unknown Supernals, for one's mental equilibrium will be in danger. The light of the Hyperborean Siddhas must be INSINUATED to the viryas, for those who are chained to the material world, i.e., in strategic confusion, could not directly resist the terrible Presence which will reveal to them, by that single act, their miserable condition as slaves of Jehovah-Satan. For if this were to happen, from the depths of their misery would arise THE HONOR, the only morality of the hyperborean virya, and this primordial instinct would strike him down like a thunderbolt.

That is why, when the Germanic nobles found themselves in front of the Presences, only Wilhelm resisted the terrible ordeal without losing consciousness, although his hair became white as ash and he wore it that way until his death. Wilhelm resisted because minutes before he had reached the Vril and was already a Siddha himself. And if he was still there, it was because his OMNISCIENCE had revealed to him that his presence would be necessary for the good of the race, helping John Dee in his mission. On the other hand, Rudolph II, who had failed in his attempt to reach the origin, still retained much that was human; and when confronted with the divine Presence and His Word, he was shaken in his ability to resist fright: with a sharp cry of terror he fainted.

It was a terrible and piercing cry that the German emperor uttered. So loud that it provoked the hasty entrance of the men standing guard downstairs. And this irruption put an end to the experience. The surprised and rude soldiers witnessed an unusual spectacle as they entered the upper room of the tower: those who entered first thought they saw in the center of the enclosure a circle of fire and smoke spinning violently and, inside it, blurred, some people seemed to move. But the fiery effluvium that enveloped those present quickly vanished, and so it could be seen that the emperor was lying on the floor, attended by Count von Rosemberg, curiously gray-haired, and by the strange guest.

Hours later, in the royal bedchamber, the emperor was looking as if he were  
He was boiling with fever, and at times he sat up with his eyes wide open.

while shouting unintelligible phrases. Then he would laugh out loud or burst into hysterical sobs. Doctos Hagecius, more concerned with his own future than with the emperor's health, persistently questioned Count von Rosenberg:

- *You must know what has happened to him, Count. You are wrong not to trust me, for perhaps the emperor's salvation depends on what you can tell me. -* I lowered my voice so that John Dee, standing at the foot of the bed, would not hear, *"If it is a spell that the Englishman has practiced, know noble sir that we can annul it. Or we can compel him to confess his magic. I think you must speak before it is too late.*

- *The foreigner has done nothing wrong,"* said the count with annoyance, *"He has told us part of his investigations, and this account, because of its realism, has impressed the emperor very much.*

- *Well, that was convincing!* -exclaimed Dr. Hagecius ironically, *"His eloquence must be as good as that of Cicero, the Roman.*

- *You are making a grave mistake in mocking and doubting my word, for things have happened in the way I have told you,"* replied the Count in an offended tone. *The emperor will confirm this to you when he recovers; for, I assure you, his illness is only temporary. He only needs to rest, and you would do well to provide for his sleep with some grass.*

- *You must forgive my jealousy,"* Hagecius apologized, *"but it is the emperor's health that concerns me and makes me impolite. And your image? Have you looked in a mirror? You are a mess, Count! Your hair has grayed twenty years and your face is not far behind. Look, I don't wish to offend you, but you must remember that I am an old doctor and I have seen all kinds of ailments. Once, many years ago, I attended a poor peasant who had been frightened by a bear. The man was threatened by some gypsies that he would be bewitched and haunted by the devil. One night, as he was returning from his work, he felt the presence of someone behind him. When he turned around he remembered the threat of the gypsies; and when he saw the enormous body standing before him, he had no doubt that he was in front of the devil. Fortunately the shriek of terror which he uttered drove the beast away; but look how curious, his appearance after such a trance was similar to that which the emperor now presents. That is why I think that, apart from hearing what the Englishman was telling you, you must have seen something....*

- *We have seen nothing,*" the count affirmed vehemently. *No demon visited the tower while we were there; and I repeat that the emperor will soon recover.*

- *I am astonished at your confidence in his recovery, since you are not a physician,*" said Doctor Hagecius with renewed irony. *But in one thing I will listen to you: I will administer poppy juice to the emperor... and I will call Scotus to perform an exorcism.*

Thus ended that unforgettable night: Rudolph II in the stupor of adoration while Scotus celebrated his exorcist rites; Wilhelm von Rosemberg and John Dee, now comrades in the same "closed circle", planning the future; and Hagecius, Kelly and the papal nuncio GEORG VON LOBKOWITZ conspiring to liquidate John Dee....

## **VI.**

But let us leave these earthly characters for the moment and return to the tower, an instant before Rudolph II uttered his terrible cry. We said then that the Hyperborean Siddhas had spoken. Can we know what they said? Is it possible to gather even a pale reflection of those eternal voices? We will only try to INSINUATE their message. But first it will be necessary to say something about these magnificent Presences. It will be very brief, for nothing should be added to the greatness that the mere mention of their names evokes in the Minne of every virya.

To begin with, it should be made clear that these were not the "angels" who usually COMMUNICATED with John Dee in England and whom he had not been able to CONTACT for some time - curiously since Kelly's "chance" appearance. No. These of Prague were infinitely more terrible beings than those whom he saw in the stone mirror, back in beautiful ALBION. And their surprising manifestation immediately enlightened John Dee that being in Europe and next to the Emperor of the Germanic peoples, changed the conditions of the experience very much, or rather, affected the QUALITY of it. For one of the Siddhas was he whom the North Germans call ODIN, but whom the East Germans, those who were guided by him from Mount ELBRUZ to Europe, more properly call WOTAN, the Lord of the WALHALA. Terrible and overwhelming presence of this Divine Hyperborean whose distant REMEMBRANCE is firmly engraved in all Germanic people. However, although sublime and shocking, this image of the

Wotan, who truly infused a paralyzing terror was his KAMERAD, the Divine Hyperborean Anael. This absolutely igneous Being, also known as the Lord of Venus, induced with his resplendent and flaming Presence the immediate perception of an order foreign to the material Universe, of worlds whose vision is forbidden to the slaves of Jehovah-Satan. For if Wotan, the ancient heroic guide of the Germanic peoples, will be the one who will henceforth raise up those peoples and drag in that rebellion the whole Indo-Aryan white race until the end of the Kaly Yuga, Anael is the Lord who will act during the decomposition and the catastrophe in which the GOTTERDEMNERUNG will manifest itself here on Earth. He is the one who will guide in the dark days of the West the Asian hyperborean peoples of yellow race until placing them at the forefront of humanity through the NATIONALSOCIALIST alliance with hyperborean peoples of Africa and Latin America. But that will be after terrible struggles, when the millenary and satanic work of the Sinarchy will be in sight and the end of the Kaly Yuga will come. Then a new civilization will be born, whose head will be in the South, possessing the most ancient secrets of the Hyperborean Wisdom, and entirely dedicated to the search for spiritual liberation and COLLECTIVE MUTATION. It will be at that time, after the Synarchic work has been destroyed and sufficient STRATEGIC ADVANTAGE has been achieved, that the Hyperborean Siddhas will again show themselves to the sight of the viryas, accompanying that planetary event which will signal the definitive end of SPIRITUAL SLAVERY: the Parousia of Christ-Lucifer.

We have already said, just now, who were the Hyperborean Siddhas who that night of 1585 manifested themselves in the sight of John Dee, Rudolph II and Wilhelm von Rosenberg. Let us now listen, let us try to do so by appealing to the REMEMBRANCE OF PURE HEALTH, to what the Exalted Beings said. They were words expressed in the BIRDS' LANGUAGE; concepts that we can barely INSINUATE in profane languages, more appropriate to compose the showy and deceitful SLOGANS of the Synarchic Strategy than to expose transcendent ideas. That is why we demand prudence when reading what follows, since we have tried to express the inexpressible with the only intention that it NOT BE READ TO LEARN BUT TO RE-CORE, EACH ONE HIS OWN VERSION OF THE TRUTH.

*(The following text was omitted, perhaps the author decided not to publish it).  
lo.)*

## EPILOGUE TO THE ADVENTURE OF DR. JOHN DEE

A fortnight after the events described above, Rudolph II was sufficiently recovered to receive his visitors on his feet. The emperor's illness, whose news had been quickly spread by friends and enemies, gathered around his bed a constellation of characters, some moved by the sincere concern of seeing his health broken and others, the most, at the impulse of dark and unmentionable ambitions. Among the latter were undoubtedly his brothers Matías and Maximiliano, who ardently wished to inherit the alchemist emperor. But, as it has been said, Rudolph II recovered quite a lot, although this improvement, according to Hagecius, was not complete since the emperor spent most of the days in the Tower where he suffered the fainting spell that had prostrated him.

He used to remain there for hours with a lost gaze, and it was not unusual for him to burst into bitter lamentations that no one understood. This state of affairs went on for several weeks, during which the efforts of those close to him to combat his deep melancholy proved useless. Not even the favors of his mistress Catalina Strada nor those of other kind ladies that Scotto used to present to the emperor could keep him away from the Tower. Finally, after two months of bitter reclusion, it was his faithful friend Wilhelm von Rosemberg who managed to make him reflect on the negative of continuing with such behavior.

The Bohemian nobleman, in all this, had taken care to protect John Dee upon whom the most insidious gossip had fallen. However, as the emperor recovered, his former prestige prevailed over intrigues and persecutions, and soon the English sage was seen lecturing at the University of Prague and visiting many castles where some noble and learned interlocutors tried to pry his secrets. But John Dee did not wish in any way to increase his dubious celebrity, for the risk of irritating the Catholic party was growing. On the contrary, his greatest hope was that Rudolf II would agree to save the Steganography and the manuscripts in the Enochian language.

- *Prove to me what you say,*" the emperor had promised, *"and you will obtain all t h e support you have requested from me"*. As John Dee thought, the presence of the Siddhas constituted a definitive proof of the truth of his claims. It now remained for the emperor to keep his word. And that this would happen, "there was no room for doubt," said the nobleman Wilhelm von Rosemberg, who in

He was at all times cheerfully optimistic about the success of the adventure.

Thus it was that one evening the following dialogue was established between Rudolph II and Wilhelm, whom the former had stubbornly refused to attend to since the night he fell ill.

- *Dear Rodolfo,*" pleaded the noble Bohemian, *"by the friendship we have had since the days of our childhood, by the memory of the many adventures we have had together, in short, by the terrible secrets we have shared, I beg you, in view of these affinities, which prove conclusively my eternal fidelity, to accept the advice I have come to offer you. You must overcome your grief, for which I alone know the reason, and return to courtly life. Otherwise you will do yourself irreparable harm, for you risk sinking into the darkness of madness. I know how much you suffer for the lost opportunity and how much the sentences of our guide Wotan weigh on your soul...."*

- *Don't remind me!* -cried Rudolph II, sinking his head in despair. between his hands.

- *... But what is done is done,*" Wilhelm von Rosemberg continued without noticing the emperor's interruption, *"and now we can only think of the future. It is a very important task that awaits us if we want to work for the good of the race; but it can only be done, it must be said, if we have your support. Otherwise all will be lost, beloved Rudolph, ruler of the Germanic peoples...."*

- *Do you really think so?* -asked the emperor, with a gleam of hope lighting up his light blue eyes, *"Is it possible that there is still a way to serve the terrible Gods that the Englishman has evoked, and more importantly, to avoid their wrath?"*

Rudolf II had paled visibly at the mention of the Hyperborean Siddhas; but, now more recovered, he continued speaking to his dear friend Wilhelm von Rosemberg:

- *If this is so, if you think it possible, you can count on my willingness to carry out the Englishman's plans and thus appease the wrath of the Gods. But I tell you, dear Wilhelm, that great is the effort you ask of me; for after the frightful visions I have had, the ties that bind me to life are not very strong. It will be hard enough for my weak spirit to return to the daily activities of the court.*

*- Your decision, wise archduke, is the most correct one. Be sure that you will contribute like no other to make true the motto of your House: A.E.I.O.U.<sup>1</sup> In the future, perhaps not far away, the envoy of Wotan will emerge from Austria, the one who will raise the Germanic peoples to the summit of universal power and will unmask before the world the true enemy of the Hyperborean race. And that great chief, as has been promised, will act so relentlessly against them that his name will never be forgotten by men. From Austria will be the glory, and perhaps in those days no one will remember you, Rudolph II, for the memory of men is fragile; but rest assured that in Valhalla you will live eternally with the most valiant heroes of the Hyperborean race. Follow my advice and return to ordinary life. Authorize the work of the Englishman and thereby allow those future goods to come to your House. I assure you, noble Rudolph, that such is the will of the Gods!*

With such vehemence spoke the noble Wilhelm that Rudolf II, carried away by an irresistible impulse, embraced his friend while he pronounced, moved, these words:

*- I will heed what you say, my faithful Wilhelm. Hearing you, I understand that through your mouth speaks someone higher, whom I will not contradict. I have been deeply impressed by the events with which you are well acquainted, and I have almost lost my mind; but now a new light has brought clarity to my spirit. Wait for the morrow, that I may recover my strength by rest, and then we will talk about what must be done in order to accomplish that which the Englishman has requested.*

One should not believe when reading these words that John Dee's problems were definitively solved. Many difficulties still awaited the English sage until his purpose of securing, for future mankind, the knowledge of the Enochian language and of Steganography was realized. That was the will of the Siddhas; and a Hyperborean Knight of the carat of the noble Wilhelm had joined John Dee in the mission of fulfilling it. Everything then seemed to be heading in that direction, were it not for the fact that Rudolph II became worse and worse, showing signs of a strange behavior that went as far as hostility towards John Dee and indifference to his mission. With Wilhelm von Rosemberg, his dear friend, he showed an ambiguous treatment that varied intermittently between affection and resentment. The latter, perhaps because he knew he had triumphed in the spiritual trials they had undergone together. The truth is that the emperor showed signs of being profoundly ill, with a disease so strange that no one

---

1 *A.E.I.O.U. = AUSTRIAE EST IMPERARE ORBI UNIVERSO - "corresponds to Austria to rule the whole world" - motto of the House of Austria since the 15th century.*

was able to understand among the many doctors and wise men of his court. Of course, no one knew of the mysterious events that had occurred that night in the Tower. That is why we, who have intimately witnessed the drama of Rudolph II, will try to understand his surprising subsequent behavior in the light of the Hyperborean Wisdom. In this way the events that we will narrate later, which constitute the culmination of John Dee's story and, in a certain way, point to the metaphysical origin of the Thulegesellschaft, will become comprehensible.

We have already explained in the previous chapter the reasons why Rudolph II failed when he was presented with the opportunity, through John Dee, to transmute into an immortal Siddha. It should now be added that, although Rudolph II was from that experience an "awakened virya", his failure to attain the Vril placed him at a STRATEGIC DISADVANTAGE with respect to the concrete world of the Demiurge. The concept of "strategic disadvantage" as well as that of "strategic confusion" and others, will be correctly defined in book 4. For now it will suffice to know that, analogically, strategic disadvantage is equivalent to the WEAK POINT IN A WALL; it is the desperate case of those who, having been besieged by the enemy in a walled square, find to their horror that it is incapable of resisting enemy pressure and is ready to give way at a WEAK POINT. The disaster that follows the fall of the Plaza is analogous to the loss of reason in a virya with insufficient spiritual support to maintain health during the subsequent irrational states of consciousness. That is: insanity. On the other hand, the fall of a Stronghold never represents a victory for the besieger, but a defeat for the besieged. The besieged is responsible for the fall, since he has failed to comply with the strategic law that says: "one should never raise a siege if one does not have the means to defend it". Always reasoning analogically, we will say that Rudolph II, after the hyperborean initiation administered to him by John Dee, "raised his strategic fence to undertake the return"; but when he failed to reach the Vril, he placed himself at a "strategic disadvantage". The "strategic fence" separates the virya from the world, giving him the NECESSARY TIME to go to his CHARISMATIC CENTER. On one side of it is the world of the Demiurge with its formidable Evolutionary and Synarchic Strategy; on the other, the virya, authentic monk-warrior, knight of the Grail, determined to reach the Truth.

Let us measure the forces at play: the Demiurge's Synarchic Strategy converges on the encirclement on the one hand, and the virya's Hyperborean Strategy on the other, which depends for its realization on the fearlessness and courage risked to reach the center; in short, the success of the Hyperborean Strategy depends on the virya's sanguine purity.



We have already seen that the Siddhas reproached Rudolf II for his "impurity of health" and we have studied how he retreated at the last moment, losing the possibility of immortalizing himself as Siddha (a fact that would have changed the history of the West, since Rudolf II was German emperor); an opportunity that, instead, and happily, Wilhelm von Rosenberg took advantage of. Finally, let us add that, when an encirclement has been raised, which has irritated the enemy and has led him to concentrate terrible forces for his demise, it is not easy to go back to the original situation of absence of conflict without being at a STRATEGIC DISADVANTAGE. In effect, when war has been declared and the enemy has displaced his forces, there are two alternatives: either the combat is faced by resisting the enemy siege while SEEKING ANOTHER DOOR TO EXIT, or the fight is avoided by deferring the actions and ignoring the enemy pressure. In this second case, the enemy will increase the pressure in such a way that finally the walls will give way and disaster will be inevitable: one's own strategy has failed because it has been replaced during the actions. We will explain better, but what has been said must always be interpreted analogically in relation to the history of Rudolf II who chose, evidently, the second alternative. When a virya raises an encirclement, within the framework of a Hyperborean Strategy, to INITIATE THE CONQUEST OF THE VRIL, his Strategy allows him only ONE alternative: TO OPEN THE INNER DOOR to circumvent the deployment of the demonic forces. Only one alternative. The contrary simply means a change of Strategy; and even CLAUSEWITZ knew this: NO ONE CAN CHANGE STRATEGY IN THE MIDDLE OF WAR WITHOUT RISK OF SERIOUSLY SUFFERING SERIOUSLY LOSSES. In conventional warfare, the most that is admitted in a Strategy is that it offers alternative tactics, but never that it can be changed in itself, which would mean in fact a CHANGE OF OBJECTIVE (an inadmissible possibility in a Hyperborean Strategy) that would raise severe doubts about the capacity of the General Staff that planned it and even about the validity of the justification that must always be provided for having adopted the warlike path.

But, you may ask, what specifically did it mean for Rudolph II to be at a "strategic disadvantage"? Insanity, as we have already said. The madness into which he effectively plunged in 1590 and from which he was only able to emerge briefly in 1601, until his death by COLD FIRE in 1612. Of course, the state of insanity reached in 1590, five years after the events narrated here, contributed significantly to the progressive poisoning to which he was subjected by the Druids, Jews and other agents of the Synarchy that infected his court. But let us not comment any further. Let us return to the day when Wilhelm presented himself, together with John Dee, before Rudolph II, in response to the promise he had made the day before to give a prompt solution to the Englishman's claims.

A large crowd was at the emperor's side to greet his reestablishment. Prince JOHN CASIMIRO of SAXONY-CO-BURG; the Emperor's brothers Matthias, Stephen and Maximilian; Ministers WOLFGANG RUMPF and PAUL SIX TRAUTSON; the Nuncio GEORG POPEL VON LOBKOWITZ, head of the Catholic party; to the Polish Count ALBERTO LASKI; in short, to a pleiad of ladies and nobles who gladly celebrated the physical recovery of the emperor without noticing the obvious displeasure that such a scene caused to the interested party.

When he noticed Wilhelm's presence, Rodolfo's face suddenly lit up with joy. However, his countenance immediately darkened, perhaps at the memory of his experience in the Tower; or, perhaps, at the realization that next to him was John Dee, whom the Emperor had grown particularly fearful and distrustful of. Be that as it may, he knew how to control his emotions and accepted Wilhelm von Rosemberg's greetings with a shy smile.

*- I salute the emperor and pray to Our Lord Jesus Christ that your health will continue to improve,"* said Wilhelm under the approving gaze of Nuncio von Lobkowitz.

*- I see that you are punctual, my faithful Wilhelm,"* answered Rudolf II without paying any attention to the good wishes expressed by the nobleman. *Yes, you need not remember that. I have my promise present, and if you will be good enough to tell your companion to come near, you will see that I know how to keep it.*

At a signal from Wilhelm, John Dee approached the emperor and saluted courteously, while several choruses formed among those present, some of whom approved and others condemned the presence of the "English necromancer" at court.

*- Great wonders you have done, English Knight; and, although my health has been broken, it has not been so broken as to make me forget that we had made a bargain, to which the noble Wilhelm von Rosemberg here present has been a witness. I believe that your magic has been proven, and now it is my turn to fulfill my promise. I will provide you with what you need to carry out your plans. I will give you amply, but I must ask you to release me from one part of the bargain: you will not count on my presence in the future to practice the evocation of the angels with the black stone,"* at that moment Rudolph II shuddered and was promptly supported by his valet MAKOWSKI. He took his head in his hands and a second later, having recovered, continued in this manner:

*- You have expressed the will to practice your science in my kingdom and, although you are a subject of a foreign country, I will give you permission to stay as long as you need. I will also place at your disposal the castle of BENA- TEK where you will surely find yourselves at home. There is enough there to practice Alchemy, Astrology or any other magical art you may desire; but, to see that you lack nothing, I will order that you be granted a professorship at the University. In return, you will only have to deliver a few lectures a year, to enlighten our students with your learned wisdom. I think I have been generous to you, Gentleman John Dee, but if anything else appeals to you, do not hesitate to let me know .... Now you speak. I am very anxious to see if you are satisfied.*

John Dee, who was pleasantly surprised to hear the emperor's apparently generous offer, did not hesitate to relieve the emperor of his promise to collaborate in the mission of preserving the Hyperborean Wisdom. This unthinking decision would be disastrous for two reasons: first, because the emperor's active participation in the Hyperborean Strategy to be implemented by John Dee and Wilhelm von Rosemberg was perhaps the last chance for him to regain his health; and second, because, not being bound by any ties, the emperor could - as actually happened a year later - dispose of the fate of the English sage at his whim. However, none of this was foreseen by John Dee when he replied:

*-Generous emperor: you have exceedingly fulfilled the most fanatical expectations. I cannot but express my gratitude to you by relieving you of your promise; although I know that the mission I had proposed to you will thereby be deprived of the invaluable help which your presence meant.* -He said this more out of compliment than out of real regret, for he had already made plans with Wilhelm von Rosemberg and was counting on the latter to carry them out.

*- I will order you to be escorted to the castle of Benatek,"* said Rudolph II after breathing a sigh of relief that he could disassociate himself from the plans of the mysterious Englishman. *- You may leave at once. As soon as you are ready, go to re-take your carriage at the king's quarters.... Oh, and don't forget to take the hideous stone mirror with you. Markowski!* -He called, between energetic and convulsed, to the valet, who, on the other hand, was very close by. *"Deliver to Doctor John Dee the green chest that I have left in custody in the Chamber of Wonders!*

A moment later the servant returned, preceded by a soldier carrying in his hands a small wooden chest, enameled in a beautiful bright green color.

- Inside this chest, next to the stone mirror, I have deposited a message for your sovereign, the Queen of England. In it I express to her how much I appreciate her deference in allowing such a precious and rare jewel to reach Bohemia. I also inform you that I was pleased with your presence, Dr. John Dee. And now...  
ra.....You can go, "ALS WILICHS HABEN, ALSO CEFELT ES UNS"!¹

Thus, almost with some urgency, John Dee was dismissed from the court of Rudolph II. And Kelly? What had become of the fate of the sinister Druid? After the crisis suffered by the emperor and his subsequent nervous prostration, Kelly understood that John Dee had made use of the stone mirror; and, fearing that he could convince the emperor, he began to intrigue, without further consequences, among the nobility of Prague. To understand Kelly's urgency, one must know or even imagine the terror that these "missionary" Druids felt towards their masters of Chang Shambala. For nothing in the world could a "Celtic bard" like Kelly, that is, an initiate in Druidism who has been entrusted with the fulfillment of a mission, allow himself to fail: the punishment would be terrible. And Kelly's "mission", may we remind you, was to liquidate John Dee and "recover" his treasures: the stone mirror of the Papan princess, the manuscripts in the Enochian language and the Steganography, that is, the most complete synthesis of the Hyperborean Wisdom ever seen in the Christian West.

It is in this trance that Kelly, unable to enter the court of Rudolph II, and increasingly distanced from John Dee, decided to increase his prestige as an alchemist by performing exhibitions of "transmutation" before any nobleman who wanted to open the door of his palace or castle.

He even traveled as far away as the castle of Bavarian Elector Maximilian and the no less distant castle of Count Albert Laski in Poland. But when John Dee left with his wife and son for the castle of Benatek, Kelly's impatience turned to despair. Thus he hatched an ignoble plot to deprive the English scholar, as in the court of Elizabeth I, of royal assistance. To this end, he performed in the home of Dr. Hagecius, in 1586, a transmutation so astonishing that, even today, the descendants of the Bohemian doctor remember it and keep the piece of gold product of the prodigy. Witness to the case was NICOLAS BARNAUD, a famous Prague physician who was also in charge of

---

1 *"ASI LO QUIERO, ASI ME PLACE", a formula used by the absolutist monarchs, derived from the Latin sentence "SIC VOLO, SIC JUVEO" ("Thus I will it and thus I command it"), used in England and equivalent to the French formula "IL NOUS PLAIT AINSI" ("Thus we please").*

to enhance Kelly's prestige.

However, it was not prestige that the clever schemer was after this time. Styled by Hagecius, who wished to witness an authentic alchemical "projection," Kelly convinced the royal physician to provide him with some confidential information about the emperor's intimate life in exchange for the prodigy. Armed with some details about the sentimental activities of Rudolph II, which only the emperor or his closest friends could know, Kelly skillfully spread them throughout Prague, saying that these data had been "guessed" by John Dee using the stone mirror. The intrigue culminated successfully when on May 6, 1586 the head of the Catholic party GEORG POPEL VON LOBKOWITZ lodged a complaint with Rudolph II accusing John Dee of "being a spy for the Queen of England, a magician and necromancer" and of "bewitching the emperor with the stone mirror, by which he obtains information about his private life and important state secrets". Rudolf II's reaction was not long in coming: he had him immediately expelled from Bohemia.

John Dee, surprised by this reaction to charges in which he had no art or part, was forced to flee quickly from Benatek at the risk of imprisonment. However, he had no need to leave the country, for Wilhelm, with whom he was in constant contact, readily agreed to hide him in his own castle at ZATEK in SEVEROCESKY. But this situation soon came to the attention of the emperor, who was furious and ordered Wilhelm to expel the "English spy"; and as the emperor's anger grew, a series of incidents followed, culminating three years later, in 1589, when John Dee left Bohemia for good.

In the four years between 1585, the year in which John Dee arrived in Prague, and 1589, the year in which he had to leave the German Empire, several noteworthy events had occurred, some unfortunate and others favorable to the interests of our hero.

In the first place, among the negative facts, we can count: the increasing insistence of Queen Elizabeth I for her subject to return to London to account for the espionage carried out, an interest that was stimulated in the sovereign by Kelly and his henchmen, who were constantly sending news to the English court about the possible treason or defection of the unfortunate sage. The extraordinary news received in Bohemia in 1587 that some "strangers", perhaps "a fanatical mob", had stormed the English house of John Dee in MORTLAKE with the sole purpose of burning his valuable library of manuscripts, was also disastrous.

alchemists and incunabula. Four thousand works had been lost in the opportunity. The real motive for the attack? A desperate attempt on the part of the Synarchy to get the sage to leave Bohemia and make a quick return to London. Finally, to name only those events that caused the most inconvenience, we must not fail to consider the tremendous pressure exerted by Rudolf II on Wilhelm von Rosemberg to stop giving protection to the English scholar and to expel him from his castle. In fact, as time went on, the emperor's behavior became more and more contradictory, finally displaying open hostility towards John Dee and unusually demanding his expulsion, even threatening his friend Wilhelm with a siege of his castle with imperial troops. All this contributed to the outcome. However, the emperor who had tried so hard to ruin John Dee's plans, one year after his departure in 1590, succumbed to a state of deep melancholy motivated by despair and remorse. Dementia from which he would only emerge eleven years later, in 1601, during a brief period in which he would try in vain to repair the evil he had caused, interceding with the Czar of Russia to hire John Dee, whom he knew had been ruined and destroyed in England. Vain help, we say, because the wise Englishman would not return to the continent for anything in the world, fearful of a new conspiracy. It would be his son Arthur who, years later, would occupy a position as a doctor at the Russian court.

But that is another story. Rudolph II did not have the strength to counteract the maneuvers of his brother Matthias, who in 1608 finally seized the government of Austria, Hungary and Moravia; nor to resist the Druidic plot hatched against him: It is the Polish nobleman and alchemist MICHAEL SENDVOJ (SENDIVOGIUS), disciple of the Scottish Druid ALEXANDER SETON "THE COSMOPOLITE"; initiated by the latter in the preparation of concoctions and poisons, who gives him to drink the "amber nectar" that precipitates his death in 1612.

We had promised to mention in the background the fortunate events that happened to John Dee during the four years that he remained in Bohemia; but, in truth, we must now say that these events have been of such great importance for the history of mankind, that before them all that we have narrated of bad things is reduced, in comparison, to mere inconveniences, to simple unimportant difficulties that do not deserve to be taken into account. This was the understanding of John Dee and Wilhelm von Rosemberg, who took things philosophically and continued their mission unchanged to the end. We are referring specifically to the provisions and arrangements made by both Siddhas to preserve the Hyperborean Wisdom. Because it is by attending to this enterprise, to which both dedicated all their efforts, that we believe it is possible to synthesize what happened at the end of their lives.

The foundation of the Order Sapiens Donabatur Astris is a unique fact, from which countless benefits are derived: the foundation of the Order Sapiens Donabatur Astris.

The idea of creating a Secret Society was not in the minds of our heroes until 1586, after John Dee, forced to flee from the castle of Benatek, joined Wilhelm von Rosemberg and both evaluated quite accurately the magnitude of the synarchic conspiracy. Until then, the English scholar had devoted himself to ciphering Steganography in the Enochian language, and to preparing various treatises on this same language: a "grammar", a "phonetic method" and a "list of equivalent terms", i.e. a primitive dictionary. Wilhelm, in the meantime, was deepening the secrets of the Hyperborean Wisdom and trying to develop a strategy to preserve the "supreme knowledge" to be used for the good of humanity. Such tasks, of course, were carried out without much haste, driven only by their own convictions, by the certainty that in this way they were fulfilling the mandate of the "angels".

It was in 1586, as we have said, when they understood that Rudolph II was yielding to an alien and irresistible Will that inclined him to destroy that which he held most sacred. Rudolph II was yielding to the enemy Strategy and this capitulation allowed the two comrades to correctly evaluate the danger and become aware that it was urgent to find a definitive solution to safeguard the Hyperborean Wisdom. Both had to find a method that would make it virtually impossible, at that or any other time, to attack the knowledge entrusted to humanity by the Hyperborean Siddhas. And as there were many ideas that came to their minds to solve the problem, they decided to elaborate several alternatives and submit them to the Siddhas, evoking them through the stone mirror of the Papan princess. From such consultations came at last, in 1587, the definitive Strategy, approved by the Siddhas and perfectly feasible to be carried out by John Dee and Wilhelm von Rosemberg.

Let us examine this strategy carefully, for the success of this strategy made it possible that three hundred years later, in the darkest period of the Kaly Yuga, there would emerge radiant and august, bearing the laurel of Roman victory and the Aryan swastika of the return to the origin, THE HYPERBORN EAGLE OF THE THULEGESELLSCHAFT.



*In this book divided into volumes, the author describes in fullness the supreme gnosis of the Hyperborean Wisdom. The terrible knowledge that, once acquired, transforms the sleeping man into a superman. The creation of the universe and of man are also profoundly described.*



# STRATEGY DEVELOPED BY JOHN DEE AND WILHELM VON ROSEMBERG IN 1587 CALLED "STRATEGY A1".<sup>1</sup>

## I - STATED OBJECTIVES

a - To preserve the Hyperborean Wisdom.

b - To ensure that, in addition to preserving current knowledge (1587), it can also be increased over time with new contributions.

c - Preserve the Enochian language.

d - To update in each century, in the greatest secrecy, the Hyperborean Wisdom to the intellectual level of the time and to elaborate ways of individual and racial mutation to be used at the time when the H.H.H. guideline is fulfilled.

e - Maintain a permanent observation of the evolution of History, recording all the important events of each century from the hyperborean perspective, paying special attention to the tactical deployments of the demonic forces of Chang Shambala (Sinarchy), but without ever intervening or allowing such observation to be noticed by the enemy, except for the exception of the H.H.H. guideline.

f - In spite of the difficulties that may arise in accomplishing these objectives, they will be carried out unfailingly by viryas trained for this purpose, who will travel around the world in fulfillment of their mission, but will be previously willing to die FOR THEMSELVES at the moment they deem it appropriate, if by doing so they contribute to maintaining the secret.

---

<sup>1</sup> *The JD and WvR Strategy is transcribed in modern language to facilitate its reading and understanding. The original 1587 criteria have not been altered in any way, although some concepts have been updated so that they can be easily identified with other corresponding concepts within the context of this work.*

g - The objectives will be considered achieved and the purposes for which the A1 Strategy was elaborated fulfilled, when the H.H.H. pattern is produced, the only condition imposed by the Siddhas to the FOUNDERS, John Dee and Wilhelm von Rosenberg.

PAUTA H.H.H.:

It is a time to come, in which the mission entrusted will be considered fulfilled when the Hyperborean Wisdom will be entrusted to an elite predestined for its use for the good of humanity, which will revolve around the SENDER OF WOTAN, THE LORD OF WAR, THE CHIEF WHO WILL LEAD THE HYPERBorean PEOPLES TO VICTORY, THE BEARER OF THE POLAR CROSS OF CHRIST-LUCIFER. This is a mystery that no one will be able to decipher before the right time.

## II. FEASIBILITY ANALYSIS AND POSSIBLE COURSES OF ACTION

(a) In order to develop a strategy aimed at meeting the above objectives, three elements are absolutely necessary:

1 - MEN capable of carrying out Strategy A1.

2 - The MEANS necessary for the right men to carry out Strategy A1.

3 - The METHOD for men, in possession of the necessary means, to accomplish the just steps that will enable them to carry out Strategy A1.

### (b) ELEMENT ANALYSIS (1)

Men capable of meeting the proposed objectives must meet certain requirements. indispensable requirements:

- Nordic" racial purity (Germanic, Anglo-Saxon, Danish, etc.) rigorously demonstrable.

- Absolute loyalty to the declared principles; they must answer with their heads for it.

- Possessing exoteric links with each other so that the secret meetings that de- to meet the objectives, never give rise to any suspicion that they are not being met.

some.

- The men who carry out the A1 Strategy must also be able to detect in advance and with absolute certainty who will be their followers, who will be selected with such precision that when the time comes for them to be initiated into the Mysteries of Hyperborean Wisdom, they will never have to retreat. They will be selected with such precision that when the time comes for them to be initiated into the Mysteries of the Hyperborean Wisdom, they will never have to back down. If such a case should occur, THE INITIATE WILL BE EXECUTED TOGETHER WITH HIS INITIATOR.

- etc.

For these and many other similar requirements is that the only possible alternative, to ensure the provision of suitable men, seems to be to form a consanguineous caste, depository of the secret, that is to say, an authentic aristocracy of blood, guardian and regent of the Hyperborean Wisdom.

#### COURSE OF ACTION

This problem was solved in the following way by John Dee and Wilhelm von Rosenberg. Between them they chose eight nobles belonging to the purest and most ancient lineages of Austria, Bohemia, Bavaria, Saxony, Mecklenburg and Brandenburg, initiating them into the Hyperborean Wisdom and incorporating them into the Great Combat.

These initiated princes signed a parchment with their blood, in the year 1589, by which they committed themselves to fulfill the objectives and to respect and enforce the law of secrecy, also establishing a perpetual alliance between their lineages in such a way that the descendants would always be linked by ties of blood and kinship. The protocol also established the precise rules to be followed in matters of marriage agreements, totally excluding from family secrecy any descendant who could not prove, in any period after 1589, the sole blood inheritance of the eight covenanting lineages. That is to say, if any NON-INITIATED descendant decided to unite in marriage with a person outside the eight trunks of the Dynasty, he WOULD NOT BE MOLESTED; but his progeny would be definitively excluded from access to the Hyperborean Wisdom. In order to comply with these rules and avoid irreparable mistakes among the initiated members of the family, they would commit themselves to carefully keep genealogical books that would unflinching have to be consulted when celebrating a wedding or at the moment of choosing those fortunate relatives deserving to know the family secret.

It would take too long to enumerate the formidable provisions made by the eight princes to ensure the element (1), the men capable of carrying forward the Strategy of John Dee and Wilhelm von Rosemberg. We will only add, to conclude this analysis, that since the number of initiated members (for esoteric reasons that we will analyze later) should never be more than 16 nor less than 8, it was agreed from the beginning that an attempt would be made to complete these numbers even WITH WOMEN, who would have the same rights to hyperborean initiation as their male relatives. Clauses were also introduced that contemplated the possible extinction of some of the lineages and discussed how to proceed in such cases. The parchment documenting this blood pact was deposited, together with the Steganography and the treatises in the Enochian language, in the old trunk reinforced with steel straps that belonged to Cornelius Agrippa von Nettesheim and which John Dee transported to Prague. For three hundred years this trunk was the very symbol of the family secret bequeathed by those eight esoterically conjured princes.

In spite of the precautions taken to ensure the future security of the family Secret Society, a hundred years after its foundation, it was already suspected that it existed. This was inevitable due to certain financial operations carried out by the initiates, which we will comment on in the following analysis. In the eighteenth century there was talk of a "Society of Alchemists" that would operate in the greatest secrecy and composed exclusively of members of the Protestant nobility of Germany, and there was even speculation that it could be the mysterious Rosicrucians or a society of Freemasons. Who first suspected and made inquiries, although without major consequences, was the Catholic Church. However, in the 19th century, serious investigations were made in an attempt to discover and destroy the family Secret Society. The attack did not come now from the Catholic Church, which on the contrary had common interests with the Dynasty, but from ILLUMINISM, the sect founded in Bavaria by ADAN WEISHAUP in 1776. This paramasonic society was one of the occult driving forces behind the revolutionary movements that swept Europe from the eighteenth century onward, and in fact was an important part of the great synarchical offensive of the nineteenth century. The Enlightenment was the first serious attempt to destroy Christian civilization; it employed subversive and revolutionary tactics and proposed to liquidate the blood aristocracies in order to distribute power among rich merchants and bourgeoisie, and no less rich Jews. It is understandable, then, that the Illuminists considered as mortal enemies the members of a Secret Society such as the one we are discussing, bearer of the Hyperborean Wisdom, that is, possessor of the necessary and sufficient knowledge to counteract the synarchic offensive. And although only the suspicion of its existence was available, we can say that a terrible secret war was waged during the whole of the 19th century against the

Dynasty; of which we will not give the details so as not to prolong the story too much, except for one that we consider highly significant: it was the Illuminists who called S.D.A., for lack of the true name, the family Secret Society. The name was taken from the ancient motto "SAPIENS DONABITUR ASTRIS", from the coat of arms of one of the eight princes who founded the Dynasty, since the corresponding heraldic coat of arms was on display in a Prussian castle where the Illuminists supposed that the Secret Society functioned. As no one ever denied this question, it continued to be called S.D.A., a criterion that we will also follow from now on; but not without first clarifying that the initiated members of the Dynasty used among themselves a name to refer to the Family Secret Society.

In fact, the secret name of the S.D.A. was EINHERJAR<sup>1</sup>, a word that alludes to the ODIN elite and which, for thousands of years, has been used to denote the societies of warrior-initiates.

In any case, as S.D.A. was known to the world, S.D.A. we continue to call her throughout the story.

#### (c) ELEMENT ANALYSIS (2)

Considering the solution given to the problem of finding the men capable of carrying out the Strategy -through an initiatory Dynasty-, the second element, THE MEANS necessary for the initiates to fulfill their objectives, can be reduced to two main aspects: "FINANCIAL MEANS" and "LOGISTIC MEANS" (or "infrastructure").

#### COURSE OF ACTION

The FINANCIAL MEANS, being a family Secret Society, could be covered by the personal wealth of the initiated members of the Dynasty. However, this solution did not seem satisfactory to the eight princes as it generated too many probable alternatives and, consequently, few guarantees of security. For example, what would happen if certain circumstances led to the personal bankruptcy of some of the members, would it bring the Society to its ruin, or would it be the only way to ensure the safety of the members?

---

1 *EINHERJAR: term obtained by the contraction of the words AI-NA-HA- RIJA of Scandinavian origin. The second of these, HARIJA, refers to the legendary HARIJ, the warrior-initiates whose indomitable courage instills terror in their enemies.*

Family secret, thus sealing the fate of the Hyperborean Wisdom? This possibility, or any other like it, was unacceptable to the princes, so they opted for a different solution. They decided to endow the S.D.A. with a treasury of its own, which, in order to make it independent of all contingencies, should act as an extraordinary reserve that could only be drawn upon in exceptional cases. Practically the treasury consisted of a security chest in which was deposited, IN METALLIC, an important amount of gold and silver to which the eight contributed equally. This reserve fund was traditionally called by the initiates: LEGATUM AUREUS.

By LOGISTIC MEANS we mean: "all those material elements that contribute to the development of the A1 Strategy and ensure its execution". Hence, the means have naturally varied over the years according to the needs, and cannot be described outside the historical context. For example, at the time of the foundation, the following were considered as fundamental logistical means: the availability of a place free from inquisitive eyes to carry out the studies of the Hyperborean Wisdom and to grant the Hyperborean Initiation; and a secret chamber, sufficiently safe to keep the Legatum Aureus and the trunks with manuscripts in the Enochian language, the Steganography, etc. The initial infrastructure to meet these needs consisted simply of a walled castle, to which were built secret sectors to which only the initiated had access. However, as will be seen below, these measures proved to be insufficient in the short term due to the Thirty Years' War and, after the end of the war, for various historical reasons, the logistical means required different elements not foreseen in the initial planning of the A1 Strategy.

In order to know with some precision the fate of the S.D.A. between the 17th and 20th centuries, and to evaluate part of what has been done in terms of financial and logistical means, we will give at the end of these analyses a HISTORICAL SCHEME OF STRATEGY "O".

#### (d) ELEMENT ANALYSIS (3)

The method must meet, among other things, the following main conditions:

1st must give, at any given time, an OBJECTIVE indication of the situation and of the enemy position.

2nd will determine with absolute certainty the moment when the H.H.H. PAUTA "IS ABOUT TO BE FULFILLED".

3º will allow the S.D.A. to INEQUIVOCALLY RECOGNIZE THE WO- ENVOY. TAN, that invincible Germanic chief on whom the H.H.H. pattern depends.

#### COURSE OF ACTION

As a general method, at the time of the founding, John Dee and Wilhelm adopted one of the seven secret ways of spiritual liberation taught by the Hyperborean Wisdom. With this way, called "OF STRATEGIC OPPOSITION", the eight princes of the Dynasty were successfully initiated; and it was decided that henceforth, the "Way of the Strategic Opposition" was to be used by the eight princes of the Dynasty, and it was decided that the "Way of the Strategic Opposition" was to be used by the eight princes of the Dynasty.

S.D.A. is devoted to cultivate the corresponding SECRET TECHNIQUE, whose name (updated) is: ARCHEMONIC TECHNIQUE.<sup>1</sup> In order to fulfill the above-mentioned conditions, we proceeded as follows: using ancient hyperborean techniques (which, however, a hyperborean initiate can always know), John Dee designed a SYNCHRONISTIC STATE DETECTOR, an instrument that allows us to know at any moment our own strategic situation and the enemy's position.<sup>2</sup>

The Detector presents the external aspect of a game of chance, which should not be surprising given that numerous "games" such as the Chinese I-CHING, the Inca game of pallares beans, the Greco-Roman dice game, the Hindu chess, the Chinese-Japanese go, etc., are all the profane expression of ancient detectors whose esoteric use was lost and which, after an "exoteric fall", were destined for "pastime" or "entertainment". Current science was only able to quantify "chance" on the basis of "discrete mathematics", but without reaching significant results because the relationship between the metaphysical sense of number and its ontic reality has been lost. That is to say, the acausal relationship that exists between the collective archetypes of the human unconscious, of which numbers are a part, and the collective psychoid archetypes that support the forms of the concrete world, which are more reducible, is unknown. For this reason, the IGNORANCE OF ESSENTIAL PRINCIPLES, even with the extraordinary science of CYBERNETICS, is not possible at all.

---

1 *Declension of ARCHEMONA, a word composed of two Greek words: arch = PRINCIPLE and monaz = UNITY. The initiation by the ARCHEMONIC TECHNIQUE allows to reach a UNIQUE PRINCIPLE of the psyche, that is to say,*

*the individuation and the VRIL.*

2        *The Detector works on the basis of an A-CAUSAL principle that is studied in the 4th book.*



via understanding and explaining the "functioning" of such a simple "game" as ICHING. This is one of the so-called "divinatory games" whose apparent power is to "detect" "what is going to happen" in "response" to questions previously formulated by the player. Sticks or coins are tossed AT RANDOM SIMILARLY with the formulation of the question. Then, the POSITION of the sticks (or coins) is INTERPRETED, according to the "hexagram" obtained, using an ANALOGICAL PROCEDURE OF SYMBOLIC REDUCTION based on Tradition, in the consultation of "sacred books" or "philosophical manuals" dictated for that purpose by sages who lived millennia ago. Here is where the "fall" of the game can be appreciated; for THE STATE SYNCHRONISTIC DETECTORS DO NOT EMPLOY REGULATIONS. Any regulation or formal rule is alien to its meaning, contrary to its nature and a sure sign that its use is unknown (either because it was "forgotten" or because the initiate who designed it did not reveal it).

Finally, any synchronistic detector is a TACTICAL ELEMENT, such as a radar, an alarm or a watchtower, designed exclusively for its use in a given strategy. In the detector the most important thing is its tactical function, to which the construction of the detector has been "adjusted", so that outside its strategy it is of no use and its "results" cannot be reasonable for anyone. This is what happens with the aforementioned games, in truth detectors, which are residues of remote strategies whose key was lost millennia ago and with it its meaning, having to add a "regulation" to force a meaning that, of course, is no longer the same and never will be.

The instrument designed by John Dee, Wilhelm von Rosenberg ironically called it the MESSIAH'S GAME; since it would make it possible to discover that final time in which the envoy would manifest himself ... of the Hyperborean Siddhas.<sup>1</sup> But this was not the only reason for such a denomination. To prevent the possible fall of the detector into profane hands (which never happened), it was built disguised in a "MAQUETTE" of a Christmas crib, so that no one who was not in on the secret could see in it anything but a beautiful representation of the "birth of the child Jesus". The detector itself consisted of a board and three bodies to be thrown on it. The board exhibited on its surface skillfully drawn a number of signs and runes, which kept a certain

---

1 *It also alludes to the myth of the IMPERIAL MESSIAH, so dear to the Germans. However, every myth is symbolically referred to true facts: "Someday Federico, the sleeping emperor, will return to restore the Universal Empire".*

related to the megalithic constructions of Europe<sup>2</sup> ; the bodies were three different polyhedrons, also with signs engraved on the faces. As a "CAMOUFLAGE", a "hut" of reduced dimensions was placed on the board, like a stable, surrounded by an infinity of small figures exquisitely carved: the cradle with the child God; the virgin mother; the magi, Joseph the carpenter; diverse animals like the horse, the donkey, the goat; some trees and bushes; rock reliefs; etc. Among so many miniatures no one would have been able to discover the polyhedrons, perfectly assembled in some statuettes, nor is it probable that he paid attention to the board that served as a floor because, no matter how much faith the observer had, he would surely be amazed to see the evangelical meticulousness with which the sacred birth had been represented.

But let us leave aside for a moment the security measures taken by John Dee and Wilhelm von Rosenberg; let us strip the "messiah game" of its accessory elements and ask: in what way could this game fulfill the conditions set forth in the analysis of element (3)? The answer is that the detector only satisfied (which is really a lot) the first two conditions: it gave an objective indication of one's own and the enemy's position AT ANY TIME, JUST BY THROWING THE BODIES ON THE BOARD. AND

would also make it possible to know the TIME in which THE SIDDHAS' SENDER would manifest himself, according to the WINNING POSITION of the polyhedra on the board. In fact, although there are no rules for the game of the messiah, the only position of the pieces that indicates THE END OF THE OWN STRATEGY, that is, THE CONCLUSION OF THE TARGETS SET, is well determined, thus rendering useless any further action, since it would lack strategic motivation. In the same way, when the strategy that gave rise to it disappears, the meaning of the Game is annulled since, as there is no conflict (OPPOSITION), there are no strategic positions to be detected. That is why a winning position has been determined: to indicate that the game is over.

Of course, this naïve statement hides the terrible real consequence that follows from the "winning position", i.e. the end of the game: that the Time of the messiah has come....

It is understood that an instrument of this nature must be handled with extreme care; but surely the unsuspecting reader will be surprised to learn the rigorous manner in which it was operated by the S.D.A. initiates and the time that

---

2 *This relationship will become clear in another part of this work, when the origin and meaning of the megalithic constructions are studied.*

elapsed between each "throw". To give an idea of the first, it is enough to consider that the board had to be "oriented" geographically and that the initiate who threw the polyhedrons had to proceed according to a ritual form, in which it was necessary to pay attention to the position of the body and during which fearsome words were pronounced in the Enochian language. Regarding the latter, perhaps the most surprising thing is the fact that the Messiah's Game was to be played every thirty-five years. That is to say: the "Game" as a detector could be "consulted" whenever circumstances required it, for example, during a crisis or to evaluate alternatives. But, except in cases of extraordinary necessity, the method set by the founders established that the "normal roll" would be performed every thirty-five years, beginning in 1589, on a day and time to be determined each time according to astrological guidelines imposed from the beginning by John Dee.

Thus it turned out that the Messiah's Game was operated by the initiates of the S.D.A. only twice a century, on occasions that were of the utmost importance to them. As other guidelines given by the founders regarding the incorporation of new members of the Dynasty to the S.D.A., established that the initiations had to be practiced on fixed dates, every seventeen and a half years, it is understood that every two initiation ceremonies coincided with the date on which the messiah's game was played. It was on these occasions that the ritual took on greater significance, for after the new initiations (if there were candidates for it) the detector was operated in the presence of all the members of the S.D.A. The latter did not occur in the intermediate initiatory ceremonies, where it was possible that only half of the initiates were present. But during the double dates, when the initiation ceremonies were practiced and then the "normal pull" was performed, the charismatic climax achieved was undoubtedly superior. On those occasions it could be affirmed that the Presence of the Siddhas constituted a reality perceived by all, although it would be a useless task to try to reproduce here, with fewer words, what the initiates felt internally. It should be noted, in order to properly appreciate the exclusive and particular character of such an experience, that most initiates were only able to attend a "normal casting" once in their lives, and in fact, in three hundred years, very few were able to witness the operation twice.

In these extraordinary opportunities, when exact and meticulous astrological calculations confirmed the chosen moment, a BERSERKIR<sup>1</sup>, that is to say, an initiated KAME- RAD, proceeded to prepare the Messiah's Game for its operation. Maximum security measures were adopted for the case, it being normal for the meeting to take place in the deep secret chambers of some impregnable castle. Try, however, to witness one such ceremony, in which the initiated members of the S.D.A., all descendants of the eight founding princes, were preparing to "consult" the synchronistic state detector. We can easily imagine them by resorting to the Mystery of the Pure Blood, tracing the christic, synchronistic and acausal sutratma of the aurea catena, which unites us, as hyperborean viryas, with those who HAVE SEEN.

Let us approach, then, to one of those secret ceremonies of the S.D.A. and let us observe attentively what happened there. For the reader's amusement, let us only add that we are in a place in northern Germany, at the end of the 17th century, under the stone vault of a subway room that serves as an initiatory crypt.

The enclosure has in the center a circular courtyard, tiled with orange trapp basalt slabs, brought from Iceland especially by initiated members of the Dynasty. Completely surrounding this courtyard and forming a celestial circumference, a small channel four inches wide, completely filled with water, gives the impression that a liquid ring has been arranged around it. To enter the courtyard one must necessarily cross the thread of water; but as there is no bridge anywhere, the initiates carefully skip over it while pronouncing a password.

Inside the water ring, as we said, is the courtyard, about thirty feet in diameter. In the center of it, a black stone column with an octagonal base supports, about five feet from the ground, a beautiful reproduction of the Christmas miracle. The "maquette", which conceals in its bosom the Messiah's Play, is located in the center of the courtyard.

---

1 *In the S.D.A., whose internal name was EINHERJAR, i.e. "Wotan's elite", the initiates were called BERSERKIR, i.e. "selected warriors of Wotan". The word BERSERKIR literally means "bear-like". On the other hand, the term KAMERAD is only used at the end of the 19th century in the S.D.A., although later, in the Germanenorden and the Thulegesellschaft, it would become the common denomination of its members, even in the innermost circles. Only Himmler's S.S. took up the concept of BERSERKIR, as will be seen later, and tried to achieve in the warrior-monks of the Black Order the "BERSERKIR FUROR".*

The new building has been there since many decades ago, when other initiates, ancestors of the present ones, transported it to the newly constructed building.

The enclosure where the courtyard with its water ring is located is just below the main hall of an imposing castle. To reach it, it is necessary to enter through a secret entrance, concealed in one of the walls of the room, and descend more than eighty feet down a spiral staircase that seems to get lost in the depths of the earth. The last step leads to a gallery that surrounds eight enormous pointed arch columns, which are arranged around the initiatory enclosure and undoubtedly support part of the structure of the castle. It is therefore possible to walk through the gallery and enter the enclosure from different angles, just by crossing any of the eight pointed arches whose height is easily three times the height of the tallest man present.

At short distances on the stairs, and on both sides of the columns, oil torches provided a more than acceptable illumination for those same curious people who, curiously enough, were accustomed to face igneous demons whose false light, material and thermal, is a thousand times stronger than the brightest sun in the sky.

We have seen that through any of the arches it is possible to enter the initiatory enclosure. This consists of a large octagonal room of about sixty feet between opposing columns, that is, twice the diameter of the central courtyard. The furniture here is scarce, contrasting enormously with the sumptuousness of the upper rooms of the castle, since it consists only of two trunks at the foot of each column and a small table in front of each trunk.

Let us now prepare ourselves to witness the arrival of the initiates.

Fifteen people descend the winding, stony staircase. They do it one by one, respecting the reduced dimensions of the steps; and, although the previously lit torches offer abundant light, the man who breaks the march carries in his hands a Roman lamp with two lit asbestos wicks, of the so-called "oil lamps".

The first to arrive at the gallery, the man with the lamp, turned to the right and began to walk at a good pace until he stopped in front of one of the arches. Those who preceded him continued walking in the same direction, although some of them stopped in front of the arches through which they were assigned to enter the gallery.

initiation.

These people are dressed in a way that would be more appropriate to the fastidies of a French court than to that secret and solitary environment. In fact, a few minutes ago they were all in a situation more in keeping with their attire, for they had just dined in the upper room of the castle, surrounded by the comforts and luxuries reserved for the high dignities of the nobility and the clergy. Whoever had witnessed the previous feast, would no doubt hastily draw the conclusion that the passers-by constituted a family group in no way different from those who in those days were engaged in the noble tasks of their class and condition: eating, drinking, waging war, administering the patrimony of the land or the goods of the Church, etc. Yes; those who had dined in the castle corresponded perfectly to that frivolous image; and it should not be surprising that they succeeded in deceiving any observer. For in reality, as we have already seen, these people were the initiated members of the Dynasty, custodians of the Hyperborean Wisdom and executors of the A1 Strategy. It was precisely on the simulated adaptation and integration to the customs of the time that the security of their mission depended to a great extent.

Let us review the fifteen relatives who dined cheerfully that night, and ask ourselves: what would become of them if anyone suspected them of their secret activities? But we have already had the opportunity to see how zealously the officials took care to avoid future evils, and those present were magnificently up to the occasion. First of all, there were two representatives of the Church: an archbishop from an important city on the Rhine and a bishop from Upper Bavaria. The only two ladies contrasted with each other in spite of their kinship: the older one was the Castilian, a widowed countess who in her youth was famous for her beauty, but who now looked no less resolute, energetic and majestic, to such an extent that her gestures alone commanded particular respect from all present. The second lady, second cousin of the Castilian, was a young and beautiful princess, of such a cheerful and carefree character that it would be quite impossible to suspect even her participation in the most naive of secrets. She had come to the castle accompanied by her husband, a young prince, who was also her cousin and initiated berserkir, as well as Lord of a small country east of Mecklenburg. The remaining ten knights, whose ages ranged from twenty to sixty, were all territorial lords and, like the others present, vassals of the emperor. Among the ten were a prince elector, a duke, two counts and two margraves. It is understandable that it was not an easy task for these personalities to meet without arousing surprise or curiosity; and here undoubtedly the wisdom of kinship was in evidence, that

by itself ruled out many questions. There were, however, a number of difficulties that are easy to imagine: several of the initiates came from distant states and had to prepare their journeys in advance, sending messengers, as was then the custom, to the numerous territories they had to cross in order to warn their Lords. There was therefore no way of keeping the secret of the journey; although this disadvantage was compensated for by the well-devised excuses that were given as a reason for it. He had had seventeen years to plan it or "create" the need for it. Another problem, for example, was the fact that while one of those present was a great archbishop, another of them, the Elector, was a Protestant who passed for a declared enemy of the Church; in the same ambiguous situation were the other initiates on the basis of their different religious confessions. These were exoteric differences for tactical purposes, of course; but if the identity of all the participants in such a "family" meeting had been known, it could easily have turned out to be suspicious. To avoid this, several of the nobles declared destinations farther away than the initiatory castle, so that in the course of their route they "casually" came across it, stopped there as long as necessary to fulfill the ritual, and then departed immediately.

But let us return to the crypt. No sooner had the fifteen initiates passed through the pointed arches than they found themselves in the vaulted enclosure already described, within sight of the initiatory pall with its ring of water. However, none of them seemed to pay much attention to such a strange environment, perhaps because they knew it beforehand; and instead, each one resolutely headed for the trunk that corresponded to him. Each trunk contained three kinds of things: a piece of stone cut from the same mountain as the other fifteen; a complete set of warlike clothing; and two weapons: a modern Germanic sword, with a rich hilt and fearsome blade; a double-edged axe, which might be said to be as ancient as those employed millennia ago by the Cretan warriors in their particular strategy of the labyrinth. Next to these weapons was a shield of three convex sides, skillfully constructed with a riveted steel frame, which was completely covered with a thick and hard leather. In the outer center of the sixteen shields was engraved the same ancient and forbidden Hyperborean Sign of the Lords of Venus. All these objects were quickly placed on the tables set up for this purpose in front of the trunks, and then the initiates began to change their clothes. We will leave the initiates in the crypt for a moment and pause to analyze certain theoretical questions in the light of the Hyperborean Wisdom.

The Einherjar Order, or S.D.A., always practiced the rites established by the founders, John Dee and Wilhelm von Rosemberg. To understand the nature of such rites and, fundamentally, the objective they were pursuing, it would be necessary to be

Hyperborean Initiate ... or to know the Fundamental Thesis of the Hyperborean Wisdom. This thesis will be exposed in book 4; and we do not doubt, upon knowing it, many of the difficulties that arose during the reading of the Secret History of the Thulegesellschaft will be definitively overcome. But now we find ourselves in a secret crypt of the S.D.A., about to witness a strange spectacle and without yet possessing the keys to interpret it. However, it will serve us well to remember the ceremony performed by John Dee in the Tower of Prague, to initiate the Emperor Rudolph II and the nobleman Wilhelm von Rosenberg, and some concepts of the Hyperborean Wisdom that we have exposed previously. With these elements and some of the internal symbology of the S.D.A., which we will explain below, we will be able, if not to penetrate into the depths of the Mystery, at least to glimpse the presence of the Mystery itself, towards which the rituals were pointing.

We have already spoken of the VIRYAS, semi-divine men who possess in their blood the inheritance of the Divine Hyperboreans called, to simplify, "Minne". We also said that the VIRYAS could be "lost" or "awakened" and we defined the "lost virya" as one who has "lost the origin" due to a "blood confusion". Blood confusion causes a psychological state of great misdirection which is technically called "strategic confusion". Consequently, the "blood purification" facilitated by the Hyperborean Wisdom, by seven secret ways, produces a "strategic reorientation" in the lost virya, making it possible for him to start (or re-start) the return to the origin and the abandonment of the infernal world of matter. The "lost virya", as we have already said, is in an abject state of material enchainment that obliges him to submit to the laws of Karma, to periodically reincarnate and live, or re-live, an eternal and miserable comedy marked by the sinister illusion of pain, fear and death. In the "Great Deception" of life, the lost virya can occupy any position, and even "collaborate" with the "evolutionary" and "progressive" "Plan" of Jehovah-Satan, or with his social "control system" called, also for simplicity, "Synarchy". It is not convenient to expand on the TYPO of the "lost virya" because it does not present a great mystery, since it is possible to obtain it concretely in most of the good people that inhabit the different countries of the earth.

On the other hand, the "awakened virya" deserves our greatest respect. He is the one who has become "alert" upon seeing his "disorientation" and, with firm decision, intrepidity and warrior courage, has begun to search for the origin in order to begin his return. This decision, of course, will not be respected by the enemy, who will try by all the infinite means at his disposal to confuse the daring challenger, seeking to prevent him from discovering the WAY TO RETURN, inducing him, by illusion and deception, to break his "alertness". That is why the awakened virya will only be able to have



success if he acts WITHIN THE FRAMEWORK OF A HYPERBORNE STRATEGY. To do so, he must fully assume his warrior condition, seek in the memory contained in the blood the primordial powers of the immortal spirit, the force of the Vrili, and, in a gnostic outburst, recover the ESSENTIAL HOSTILITY towards the material world of the Demiurge, experience the BERSERK FUROR. Then, already owner of an unbreakable will, inspired by the Hyperborean Wisdom of which he is the bearer by the inheritance of the Ancestral Siddhas, he will deploy his OWN STRATEGY conceived to OPPOSE the ENEMY STRATEGY and win. From there on he will only perform STRATEGIC MOVEMENTS, TACTICAL ACTIONS, aimed at NOT LOSING OF

VISTA THE ORIGIN, while the STEPS OF RETURN are executed. And, in the midst of the heat of combat, or worse, in the expectation of it, when the enemy forces masked in the illusory forms of this and the other worlds let their diabolical threat show, the awakened virya coldly seeks to MAKE TIME, however minimal it may be, to MOVE IN THE DIRECTION TO THE ORIGIN. The right to have that OWN TIME, perhaps as fleeting as the smallest instant, must be won in a fierce struggle against the demonic legions of the Demiurge, against the poetic spell exerted by the sensible world (with its thousand possible concupiscences) which we call the Great Deception, in short, against the Will of the One. It seems an impossible task. The Hyperborean Wisdom, and even the Gnostic Tradition, affirm that it is possible. But then, how to do it?

The answer to this question is dealt with in the seven secret ways of the Hyperborean Wisdom. And, we already said at the beginning of this "course of action", that the method of John Dee and, consequently, the rituals of the S.D.A., were based on one of such ways called "OF STRATEGIC OPPOSITION" and on its corresponding secret technique (ARCHEMONIC TECHNIQUE). Therefore, it is possible that the reader, if he heeds all that has been said so far about the lost viryas and listens to the voice of their blood, WILL FIND SIGNIFICANT the ceremony he is about to witness. It is part of the answer that the Hyperborean Wisdom gives to the question posed above; but NEITHER WE NOR ANYONE else would attempt to answer that question DIRECTLY. Precisely, the ritual constitutes an analogical answer, the only one possible during the Kaly Yuga, and it will depend on the reader's capacity of semiotic induction the "knowledge" he can obtain from a mere description.

We have shown that, even ignoring the Fundamental Thesis of the Hyperborean Society, it is possible that the ritual of the S.D.A. may be significant for us if we relate it analogically to "the quest of the awakened virya", that is to say, to its own strategy. But let us remember that the initiates of the S.D.A. are awakened viryas who have been entrusted with a mission to be accomplished as long as they reach their blood purification; that is, they have assembled their own

strategy.

This makes things easier because, in the framework of such a strategy, it is quite easy to perceive the Siddha who illuminates the charismatic center, or the "closed circle". This makes things easier because, within the framework of such a strategy, it is quite easy to perceive the Siddha who illuminates the charismatic center of the Order, or of the "closed circle", and to be guided by him to the origin, achieving the mutation and transforming himself also into Siddha, into an immortal Divine Hyperborean. But in this case, honor prevents the virya from abandoning the totalizing strategy, even though his own strategy has concluded. He then decides to continue to operate in the world for the good of the race, preparing the conditions for the return of the Ancient Hyperborean Guides of humanity. This is the only difference that must be taken into account when observing the viryas of the S.D.A.: that an awakened virya, on concluding his own strategy and reaching the Vril, immediately leaves the infernal regions; on the other hand, an initiate of the S.D.A., awakened virya or immortal Siddha, has to continue the combat for a while longer in favor of his lost comrades.

It is now useful to make an elementary introduction to the internal symbology of the S.D.A. to further facilitate the interpretation of the ceremony.

For the BERSERKIR, initiates of the EINHERJAR or S.D.A., the "world" in which daily life takes place is simply a "battlefield", a PALESTRIUM full of mortal enemies that must be fought without respite because they "cut the way back", "obstruct the retreat" and intend to "reduce us to the vilest slavery" which is "the submission of the immortal spirit to matter", its "enchainment to the Evolutionary Plan of the Demiurge and his court of demons". The "world" is then, for the berserkir, THE VALPLADS<sup>1</sup>. Is there then no place where the warrior can rest his weapons, a place where for even a second it is possible to distract his attention from the enemy and fix it on the golden origin? Neither such a place nor such a time exist by themselves, but they can be created strategically. In VALPLADS there is no other possibility but to fight or surrender, an alternative, the latter, which implies sinking into the idiocy of the lost virya. But the one who fights can "liberate" a place and become strong in it. For this, the way of "strategic opposition" teaches the "archemonic technique", which includes the important concept of the "encirclement function". According to the Hyperborean Wisdom, which says: "every closed curve divides its plane into two parts". A closed curve can have any shape, square, circular, elliptical, etc., but it always presents the qualitative fact that it divides its plane into two parts. The geometric property that expresses this

---

1 *VALPLADS: In Norse mythology and EDDA it is the battlefield where*

*Wotan chooses those who fall fighting for honor or truth. The S.D.A., based on the Hyperborean Wisdom, extended the concept of VALPLADS to the whole "world".*

The theorem, which is easily intuitive, is important to us because the "closed curve" is the most

abstract of "fence" and an obvious starting point for the definition of the concept.

Man applies the "hedge principle" when he makes the formal differentiation and distinguishes between "an outside" and "an inside"; but such a property is not exclusively human, but other animals also possess it, as ethology has shown. Animals with a "notion of territory" also use the "hedge function" to delimit their "living space" or lebensraum. But ethology, starting from the scientific premises of Darwinian evolutionism, fails to interpret the data obtained from empirical observation, and only manages to define a "territory function" common to "territorial animals", i.e. those that delimit an area as their own and defend it from any enemy intrusion. This is seeing only a part of the problem and, surely, ethology would advance much more if it used the concept of "fence function" taught by the Hyperborean Wisdom.

The archemonic technique allows every awakened virya to apply the hedge function in the VALPLADS environment and to "divide the space into two parts". The "inner" part of the fence or "archemone"<sup>1</sup> will be immediately occupied by the virya who will have thus STRATEGICALLY CREATED the place from where he will LOOK towards the origin. THE PROPER TIME necessary for this will be CREATED from the archimony by means of STRATEGIC OPPOSITION, a technique that requires THE DEFINITION OF A PLACE, A POINT, ETC., IN THE VALPLADS, that is to say, "outside" the archimony. This outer "point" usually consists, for practical purposes, of a stone, as John Dee operated in the Prague Tower, performing the "opposition" with the stone mirror of the Papan princess. The berserkir used, as we saw inside the trunk, each one an unpolished stone, cut from the same mountain. Against these stones they performed the strategic opposition that allowed them to "desynchronize" themselves from the time of the VALPLADS, that is, from the "time of the world" and to create their own time WITH WHICH TO GAIN STEPS TOWARDS THE CENTER.<sup>2</sup>

We should now pause for a moment and make a very brief summary of the which will allow us to synthesize some conclusions.

---

1 *The "archemonic technique" is the adaptation to modern culture of a very ancient hyperborean technique based on the "hedge function". All the mandalic systems of the various post-Atlantean cultures derive from this technique and it can be affirmed that the archemone and the hedge function are the true foundations of the mandala.*

2 *The theory of time held by the Hyperborean Wisdom will be expounded in*

*book 4.*

The main objective of the awakened virya is to orient himself toward the center-origin. A powerful enemy Strategy acts upon him, the purpose of which is to keep him in confusion. The enemy Strategy dominates space and time. Space "belongs" to the enemy because in the totality of the material universe there is a pan-theistic diffusion of the Demiurge and his devic Hierarchy. Time "is" of the enemy because "time is the constant flow of the consciousness of the Demiurge". The human body occupies space and contains matter of pantheistic manifestation. It also possesses temporal biological functions ("biological clocks") synchronized with other solar and lunar rhythms, apart from the main function, "consciousness", occurring in time. Therefore, if the immortal spirit seeking to free itself from material chains is overly dependent on the physical body, it will never be able to find its way out, it will never be able to "orient itself". The physical body, by itself, constitutes the heaviest chain if it is only "part" of the material universe, since it then binds us to the space and time of the enemy.

But the physical body is also a microcosm, a reflected expression of the macrocosm of the Demiurge, and as such possesses the possibility of creating its own space and its own time. But this possibility can only be realized if the condition of microcosm is first actualized, and for that it is necessary to ISOLATE the physical body from the remaining material order. This means, among other things, attaining physical immortality as a consequence of the independence with which the vital cycle of the microcosm develops with respect to the macrocosm. To make the physical body, which until now was only "a part of the world", an autonomous microcosm, independent of pantheistic space and karmic time, is the possibility offered by the Hyperborean Wisdom with its seven secret ways of spiritual liberation.

But "immortalizing oneself in a physical body" does not represent any solution to the problem of spiritual enchainment. This "conquest" is only a step in the search for "orientation"; the only, unwavering and irreplaceable goal of the virya is to reach the origin and "abandon" the material order.

To "reach the origin", let us not forget, means to "conquer the Vrill", to be "pure possibility", and implies the certain abandonment of the material hell, sublime instant in which the physical body, now immortal, or microcosm, surrenders itself for its fusion with the macrocosm.

The physical body must be given its just value as an extremely useful instrument for the strategic purposes of the captive spirit in its march toward the origin. For this, it is necessary that the physical body actualize its spatio-temporal potentialities and transmute itself into a microcosm. The "way of opposition

The "strategic opposition" technique followed by the S.D.A. makes this transmutation possible because the "archemonic technique" ISOLATES the physical body from the material universe, allowing it to "gain a space of its own" without pantheistic impregnation. Within this space, which the S.D.A. called "square", the technique of "strategic opposition" makes it possible to "create" a time of its own, that is, to make the "consciousness of the microcosm" independent of the "consciousness of the macrocosm" or time of the world. Here we can consider the summary concluded.

To go a little deeper, now, into the archemonic technique, we must re-take the concept of "fence". We have previously said that the hedge function appears as a "law of nature"; and we have also affirmed that THE PRINCIPLE OF THE HEDGE constitutes a structure of the human mind, that is to say, a collective archetype. This duplicity should not surprise us. If we accept the hermetic principle of equivalence between macrocosm and microcosm, it will be evident to us that ALL the laws of the macrocosm are reflected in analogous laws of the microcosm and VICEVERSA. But this correspondence between macrocosm and microcosm is far from being a mere passive reflection between structures. Man, by DISCOVERING and FORMULATING "laws", unbalances this relationship and assumes a leading role. As a consequence of this dominant attitude there now appears, between the macrocosm and the microcosm, a CULTURAL MODEL elaborated BY MAN on the basis of laws and concepts. It is this "cultural model" that is mainly responsible for the deformed vision he has of himself and of the world, since it "interposes" itself between the macrocosm and the microcosm. The cultural model contains the totality of the collective knowledge of the world (the "laws of nature" being in the first place) and, since man is its manager, a "problem of the pre-eminence of the cultural premises" is posed. In order to duly clarify this problem, we will first develop some concepts that we will soon have to make use of.

First of all, it will be useful to know what we mean by "law of nature". Without going into complications, we can state that "a law of nature is the mathematical quantification of a significant relationship between aspects or magnitudes of a phenomenon". Let us clarify this definition. Given a phenomenon, it is possible that by observation and empirical experimentation we may be able to differentiate certain "aspects" of it. If among the various aspects that stand out, some of them turn out to be "significantly related to each other"; and if this relationship possesses statistical probability, i.e., it is repeated a large number of times or is permanent, then a "law of nature" can be enunciated. For this it is necessary that the "aspects" of the phenomenon can be reduced to magnitudes, in such a way that the "significant relation is also reduced to "relation between magnitudes", that is, to a mathematical function. The "laws" of physics have been deduced in a similar way.



The concept of "law of nature" that we have exposed is modern and aims at "controlling" the phenomenon rather than explaining it, following the current trend that subordinates the scientific to the technological. Thus we have phenomena "governed" by EMINENT laws which we not only accept as determinants, but which we incorporate indissolubly into the phenomenon itself, forgetting, or simply ignoring, that we are dealing with rational quantifications. This is what happens, for example, when we notice the phenomenon of a falling object and we affirm that such a thing has occurred because "the law of gravity acted". Here the "law of gravity" is eminent and, although "we know that other laws exist" which "also intervene, but with less intensity", we blindly believe that the object in its fall OBEYS Newton's law and that this "law of nature" has been the CAUSE of its displacement. However, the concrete fact is that the phenomenon DOES NOT OBEY ANY EMINENT LAW. The phenomenon simply HAPPENS and there is nothing in it that intentionally points to a law of nature, and even less to an eminent law.<sup>1</sup> The phenomenon is an inseparable part of a totality that we call "reality", or "the world" and that includes, in that character, ALL phenomena, those that have already occurred and those that will occur. That is why in reality phenomena simply OCCUR, perhaps succeeding some that have already occurred, or simultaneously with others similar to it. The phenomenon is only a part of that "phenomenal reality" that never loses its character of totality; of a reality that is NOT expressed in terms of cause and effect to sustain the phenomenon; in short, of a reality in which the phenomenon OCCURS independently of whether or not its occurrence is significant for an observer and whether or not it complies with eminent laws.

Before approaching the problem of the "pre-eminence of cultural premises" in the rational evaluation of a phenomenon, it is convenient to strip it of any possibility that would separate it from purely mechanical or evolutionary determination, according to the "natural order". For this purpose we will establish, after a brief analysis, the difference between phenomena of "first" or "second" degree (of determination), an indispensable clarification given that the "eminent laws" always correspond to phenomena of the first degree.

For the Gnostic, "the world" that surrounds us is nothing more than the arrangement of matter made by the Demiurge in the beginning and which we perceive in its temporal actuality. The Hyperborean Wisdom, the mother of Gnostic thought, goes further by affirming that space, and all that it contains, is constituted by multiple associations of a single element called "psychophysical quantum".

---

1 *We refer here to a "first degree" phenomenon. This concept will be defined*

*below.*

of energy" or "UEVAC energy unit".<sup>1</sup> The UEVACs, which are true archetypal form-forming or form-structuring archetypal atoms, each possess an INDISCERNIBLE POINT through which the pantheistic diffusion of the Demiurge takes place. That is to say that, thanks to a punctual system of poly-dimensional contact, the presence of the Demiurge becomes effective in every ponderable portion of matter, whatever its quality may be. This universal penetration, when verified by people in different degrees of confusion, has led to the erroneous belief that "matter" is the very substance of the Demiurge. Such are the vulgar conditions of pantheistic systems or of those that allude to a spirit of the world or "anima mundi," etc. In reality, matter has been "ordered" by the Demiurge and "impelled" towards a LEGAL unfolding IN TIME from whose evolutionary force not even the smallest particle escapes (and in which the "human body" participates, of course).

We have made this synthetic exposition of hyperborean "physics" because we need to distinguish two degrees of determinism. The world, as we have just described it, unfolds mechanically oriented towards a purpose; this is the FIRST DEGREE of determinism. In other words: there is a Plan to whose guidelines the "order" of the world conforms and to whose designs it tends; the matter left to the mechanics of this "order" is DETERMINED IN THE FIRST DEGREE. But, as this Plan is sustained by the Will of the Demiurge, and His Presence is effective in every portion of matter, as we have seen, it could happen that He, ANORMAL-MIND influences IN ANOTHER WAY some portion of reality, either to MODIFY HIS PLAN TELEOLOGICALLY or to EXPRESS HIS SEMIOTICALLY, as we have seen. INTENTION, or for STRATEGIC REASONS<sup>2</sup>; in this case we are dealing with the SEGUNDO DEGREE of determinism.

We can now distinguish between a PHENOMENON OF THE FIRST DEGREE and a PHENOMENON OF THE SECOND DEGREE, according to the degree of determination that involves its manifestation. It should be well understood that in this distinction the emphasis is placed on THE DIFFERENT ways in which the Demiurge can act upon THE SAME phenomenon. For example, in the phenomenon of a flowerpot falling from a balcony to the sidewalk, we can see nothing else than a first degree determination; we say: "the law of gravity acted". But if the said flowerpot fell on the head, we say: "the law of gravity acted".

---

1 *The theory of the "psychophysical quanta of energy "U.E.V.A.C." is presented in book 4. Here we advance what is necessary to outline the concept of "pantheistic control".*

2 *By "strategic motives" we mean the following: when the awakened virya undertakes the return to the origin within the framework of a Hyperborean Strategy, he employs secret techniques that make it possible to effectively oppose the Plan. In*

*these circumstances the De- miurge, ANORMALLY, intervenes with all His Power to punish the intrepid.*

of the awakened virya, we can assume a second determination or, strictly speaking, a "second intention"; we say: "the Will of the Enemy acted".

In general, every phenomenon is susceptible of manifesting itself in the first or second degree of determination. In view of this possibility, we will agree on the following: when not otherwise indicated, "phenomenon" will be understood as that whose determination is purely mechanical, that is, of the first degree; otherwise it will be clarified as "of the second degree".

Now that we know how to distinguish between "the two degrees of phenomena", we need only to clarify the statement we made at the beginning of this analysis, that all laws of nature, even the most eminent ones, describe the causal behavior of phenomena of the first degree of determination. It is easy to understand and accept this, since when a second-degree determination intervenes in a phenomenon, the natural sense of mechanical chaining has been temporarily alienated in favor of an irresistible will. In this case the phenomenon will no longer be "natural", even if it appears to be so, but will be endowed with a superimposed intentionality of a clearly EVIL CHARACTER (for the virya).

On the other hand, the phenomenon of the first degree always manifests itself COMPLEX IN ITS FUNCTIONALITY, which is a direct expression of its essence, and to which it will always be possible to reduce mathematically to an infinite number of "laws of nature". When the phenomenon of the first degree is especially appreciated by ONE law of nature, which is eminent for us because it EMPHASIZES A CERTAIN interesting ASPECT, it is evident that we are not dealing with the WHOLE phenomenon but with that "aspect" of it. In such a case, the sad fact must be accepted that only an illusion of the phenomenon will be perceived. Mutilated sensorially, deformed gnoseologically, masked epistemologically, we should not be surprised that the Indo-Aryans called the ordinary perception of a phenomenon of the first degree MAYA, illusion.

We will now pose a question, the answer to which will allow us to face the problem of the "preeminence of cultural premises", based on our last conclusions: "if every first degree phenomenon appears necessarily complete (for example: at 6 A.M. "the sun rises"), what is the specific reason why its apprehension by means of the "scientific or cultural model" prevents us from dealing with the phenomenon in its entirety. "What is the specific reason that its apprehension by means of the "scientific or cultural model" prevents us from dealing with the phenomenon in its integrity, circumscribing us around partial aspects of it (for example, when we say: "the terrestrial rotation is the CAUSE that has produced the EFFECT that at 6 A.M. the Sun has become visible on the Eastern horizon"). In this last example, it becomes evident that in explaining the

fenómeno por una “ley eminente” no hacemos más que referirnos a ciertos aspectos parciales (la “rotación terrestre”) dejando de lado —no viéndolo— al fenómeno mismo (“el Sol”). The answer to the question posed leads us to touch upon a fundamental principle of the epistemological theory that says: THE EMINENT RELATIONSHIP THAT WE ADVERTISE BETWEEN ASPECTS OF A PHENOMENON, QUANTIFIABLE MATHEMATICALLY AS "LAW OF NATURE", IS ORIENTED IN THE PREEMINENCE OF CULTURAL PREMISES FROM WHICH REASON MODIFIES OUR PERCEPTION OF THE PHENOMENON IN ITSELF.

When we make a "scientific" observation of a phenomenon, the rational functions become preeminent over any perception, "highlighting" with emphasis those aspects that are interesting or useful and "tarnishing" the rest (of the phenomenon). In this way, reason operates as if it were masking the phenomenon, previously torn from the totality of the real, and presenting it with a "reasonable" and always comprehensible appearance in the sphere of human culture. Of course, no one cares that the phenomena are thereafter hidden behind their reasonable appearance; not if it is possible to make use of them, to control them, to harness their energy and to direct their forces. After all, a scientific-technological civilization is built UPON phenomena and EVEN AGAINST them. What does it matter if a rational vision of the world cuts out the perceived phenomena and confronts us with a CULTURAL REALITY, all the more artificial the more blind we are? What does it matter, we repeat, when such gnoseological blindness is the price we must pay to enjoy the infinite variants that, in terms of enjoyment and comfort, scientific civilization offers? Is there any danger lurking that we, who have eliminated many ancient diseases, who have prolonged human life and created an urban habitat with a luxury never seen before, cannot conjure up technically?

The danger exists, it is real, and it threatens all those members of humanity who possess Hyperborean ancestors; the Hyperborean Wisdom calls it PSYCHIC FAGOCITATION. It is a danger of a psychological and transcendent order that consists in the metaphysical annihilation of the consciousness, a possibility that can take place in this or another world, and at any time. The destruction of the consciousness happens by DEMIURGICAL FAGOCITATION, that is, by assimilation of the personal self to the substance of the Demiurge. When such a catastrophe occurs, all possibility of transmutation and return to the origin is completely lost. We have already spoken about the dramatic alternative that the virya must face, and we will speak again at length in book 4; however, it is worth repeating that it is CONFUSION that is the main impediment to the transmutation of the virya into immortal Siddha. And, to the permanent confusion, contributes the gnoseological blindness that we mentioned before, product of our modern rationalistic mentality. We live according to the

The patterns of Western "culture", which is materialistic, rationalistic, scientific-technological and amoral; our thinking starts from preeminent cultural premises and conditions the world view by making it pure appearance, without us noticing it or having any idea of it, so culture keeps us in confusion, prevents us from orienting ourselves towards the center of psychic reintegration, transmuting us into Siddhas. Culture, then, keeps us in confusion, prevents us from marching towards the center of psychic reintegration, transmuting us into Siddhas. Is it by chance that such a thing happens? We have said it many times: culture is a strategic weapon, skillfully employed by those who wish the perdition of the Hyperborean Inheritance.

When the critique of the modern urban culture of the "Christian West" is made, the "evils" that it provokes in some individuals are usually detailed: alienation; dehumanization; slavery to consumption; depressive neurosis and its reaction, dependence on various vices, from narcosis to the perversion of sex; ruthless competition, motivated by dark feelings of greed and ambition for power; etc. The list is endless, but all charges deliberately omit the essentials, emphasizing evils "external" to the soul of man, originating in "imperfections of society". As a complement to this fallacy, it is argued that the solution, the remedy for all evils, is "the perfecting of society," its "evolution" toward more just, more humane forms of organization, etc. The omission lies in the fact that evil, the only evil, IS NOT EXTERNAL to man, it does not come from the world, but lies within him, in the structure of a mind conditioned by the preeminence of the cultural premises that sustain reasoning and that deform his vision of reality. Today's society, on the other hand, has managed to Judaize the common man in such a way that it has transformed him - a miracle that genetic biology cannot even dream of - into a miserable Jew, greedy for profit, happy to apply compound interest and happy to inhabit a world that glorifies usury. Needless to say that this society, with its millions of biological and psychological Jews, is for the Hyperborean Wisdom only a bad nightmare, which will be definitively swept away at the end of the Kaly Yuga by the WILDESHEER.<sup>1</sup>

We have brought out the fact that a "law of nature" originates in certain relations that rational judgment establishes between significant aspects of phenomena. Our purpose is to make it clear that although such aspects do indeed belong to the phenomenon, the relation that gave rise to the law that is emanating has been created by reason, and can in no way be attributed to the phenomenon.

---

<sup>1</sup> *In the EDDA WildesHeer is the "furious army" of Wotan. According to the Thulegesell- schaft, the Siddhas have announced the return of WildesHeer, together*

*with those who will form the "last battalion" of the eternal SS, at the end of the Kaly Yuga.*



itself. Reason, supported by preeminent cultural premises, uses the world as a PROJECTIVE or REPRESENTATION MODEL, so that any phenomenon expresses CORRESPONDENCE with an equivalent intellectual conception. In this way, man makes use of rational concepts of the phenomenon that have a weak link with the phenomenon itself, with its truth.

When reasoning and analysis are made on the basis of such concepts, and error is added, the result cannot be other than the gradual immersion in unreality and confusion. This effect is sought by the enemy, as we have said. We will see later how the Hyperborean Wisdom teaches the way to avoid it.

In mentioning the Hermetic Principle above, we said that all the laws of the macrocosm were reflected in equivalent laws of the microcosm. But "the laws of nature" of the macrocosm are but representations of a mathematical mode originating in the human mind, i.e., in the microcosm, as we have discussed. In the process that gives rise to the "scientific idea" of a phenomenon, elements from two main sources concur: the "mathematical principles" and the "preeminent cultural premises". The "mathematical principles" are archetypal, they come from inherited psychobiological structures (when we "learn mathematics", for example, we only consciously actualize a finite number of formal systems belonging to the realm of culture; but the "mathematical principles" are not really "learned" but "discovered", since they constitute basic matrices of the structure of the brain). The "pre-eminent cultural premises" arise from the TOTALITY of the cultural elements, learned throughout life, which act as conscious or unconscious content of the memories and records and to which reason resorts to formulate judgments. (By "reason" we understand here an OPERATOR that relates different elements according to a certain "logic". The "operator" is HEREDITARY; the "logic", that is, the AGREED MODE of operating, is CULTURAL: it depends on social, ethical, moral, etc. rules and principles, and is closely linked to one's own linguistic structure, to one's native language).

The distinction we have made between "mathematical principles" and "pre-eminent cultural premises" as the two main sources involved in the mental act of formulating a "law of nature" will enable us to expose one of the most effective tactics employed by the Demiurge to keep the viryas in confusion, and the way the Siddhas try to counteract it by charismatically inducing them to discover and apply the "law of encirclement". That is why we have insisted so much on the analysis: because we are before one of the most important principles of the Hyperborean Wisdom and, also, one of the secrets best kept by the enemy.

When the principle that "for the Synarchy, culture is a strategic weapon" is known, it is often thought that it refers to "culture" as something "external", proper to man's conduct in society and the influence it exerts upon him. This error stems from an incorrect understanding of Sinarchy (which is supposed to be a mere "political organization") and the role it plays in the Plan of the Earth Demiurge Jehovah-Satan. The truth is that the virya tries to orient himself towards the origin and does not succeed because of the state of confusion<sup>1</sup> in which he finds himself; to maintain him in that state contributes the culture<sup>2</sup> as a strategic enemy weapon; but if this attack came ONLY from the outside, that is, from society, it would be enough to move away from it, to become a hermit, to neutralize its effects. However, it is sufficiently proven that solitude is not enough to avoid confusion and that, on the contrary, this usually increases in the most hermetic retreat, being very likely that by this way reason is lost long before the origin is found. It is the INNER cultural elements that confuse, divert and accompany the virya at all times. That is why the conscious self must PREVIOUSLY free itself from the obstacle imposed by the cultural elements if it intends to bridge the distance that separates it from the Vrîl.

A self stripped of all morality, of all dogma, indifferent to the deceptions of the world, but open to the memory of blood, will be able to march gallantly towards the origin and there will be no force in the universe capable of stopping it.

It is a beautiful image that of the virya who advances intrepidly, wrapped in warlike fury, without the demons being able to stop him. We always present it; but, you may ask, how is it possible to acquire such a degree of purity? Because the normal state of the virya, at this stage of the Kaly Yuga, is confusion. We will now explain, in answer to such a sensible question, the tactics of the Siddhas to GUIDE the lost viryas and neutralize the effect of the synarchic culture.

In the lost virya the self is subject to reason. It is the rudder that guides the course of his thoughts from which he would not deviate for anything in the world; outside of reason are fear and madness. But reason operates on the basis of elements

---

1 *There are various degrees of CONFUSION. The "strategic confusion", which we have already mentioned elsewhere, originates in blood impurity. The "CONFUSION" discussed here is the psychological expression of strategic confusion.*

2 *Culture is a social, collective fact. Man, as a member of that society, participates and is internally nourished (is "structured") by it. But "culture" is not a spontaneous fact; it possesses "control variables" skillfully manipulated by the Synarchy, which "directs" it in the sense of its plans.*

We have already studied how the "preeminent cultural premises" participate in the formulation of a "law of nature". So the yoke that the enemy has tightened around the self is formidable. We could say, figuratively speaking, that the self is PRISONED by reason and its allies, the cultural prizes; and everyone would understand the meaning of this figure. This is because there is a clear analogical correspondence between the ego, in the lost virya, and the concept of "captivity". For this reason we will develop below an allegory, in which the correspondence will become evident, which will allow us to understand the secret strategy that the Siddhas practice to counteract THE CULTURAL WEAPON of the Sinarchy.

Let us begin to present the allegory by focusing on a man who has been taken prisoner and sentenced, without appeal, to life imprisonment. He is unaware of this sentence, as well as of any post-capture information from the outside world, for it has been decided to keep him indefinitely incommunicado. For this purpose he has been locked up in an inaccessible tower which is surrounded by walls, chasms and moats, and where any attempt to escape is apparently impossible. A garrison of enemy soldiers, who cannot be approached without punishment, are permanently guarding the tower; they are ruthless and cruel, but terribly efficient and loyal: do not even think of buying them off or deceiving them. Under these conditions there does not seem to be much hope of the prisoner ever regaining his freedom. And yet the real situation is quite different. Although the exit OUTSIDE the Tower is cut off by walls, moats and soldiers, FROM INSIDE it is possible to go directly to the outside, without encountering any obstacles. How? By means of a SECRET EXIT whose access is cleverly concealed in the floor of the cell. Naturally, the prisoner is unaware of the existence of this passageway, as are his jailers.

Let us now suppose that, either because he HAS BEEN CONVINCED that it is impossible to escape, or because he DOES NOT KNOW his captivity, or for any other reason, the prisoner shows no predisposition to escape: he does not show courage or daring and, of course, does not seek the secret way out; he has simply resigned himself to his precarious situation. Undoubtedly it is his own negative attitude which is his worst enemy, since, if he were to keep alive the desire to escape, or even if he were to experience the Nostalgia for lost freedom, he would turn around in his cell where there is at least a one in a million chance of finding the secret way out BY CHANCE. But it is not so; and the prisoner, in HIS CONFUSION, has adopted a mild demeanor which, as the months and years go by, becomes more and more pusillanimous and idiotic.

Having given himself up to his fate, one could only hope for outside help for the captive, which can only consist in the REVEALING OF THE SECRET EXIT. But it is not so simple to expose the problem, since the prisoner does not wish it or does not know that he can flee, as we have said. Two things must therefore be accomplished: 1st, to make him assume his condition as a prisoner, as a person whose freedom has been TAKEN AWAY and, as far as possible, to make him REMEMBER THE GOLDEN DAYS when there were no cells or cages. It is necessary that he becomes aware of his miserable situation and ardently desires to get out, beforehand: 2nd revealing to him the existence of the ONLY POSSIBILITY OF RUNNING AWAY. For it would be enough, now that the prisoner wishes to flee, ONLY TO BE AWARE OF THE EXISTENCE OF THE SECRET EXIT; he will seek and find it for himself.

Thus posed, the problem seems very difficult to solve: it is necessary to slow him down, AWAKE him from his lethargy, GUIDE him and then REVEAL the secret. So it is time to ask ourselves: is there anyone willing to help the miserable prisoner? And if there is, how would he manage to fulfill the two conditions of the problem?

We must declare that, fortunately, there are other people who love and seek to help the prisoner. They are those who share his ethnicity and inhabit a country far, far away, which is at war with the nation that imprisoned him. But they cannot attempt any military action to free the prisoner because of the reprisals that the enemy could take on the countless captives that, in addition to the one in the tower, they hold in their terrible prisons. It is therefore a question of directing the help in the foreseen way: TO AWAKEN HIM, TO GUIDE HIM AND TO REVEAL THE SECRET TO HIM.

To do so, it is necessary to reach him; but how to do it if he has been locked up in the heart of a fortified citadel, saturated with enemies on permanent alert? The possibility of infiltrating a spy must be ruled out, because of the insurmountable ETHICAL DIFFERENCES: a German could not infiltrate the Chinese army as a spy, just as a Chinese could not spy in the SS barracks. Without being able to enter the prison, and without the possibility of buying or deceiving the guards, the only recourse is to MESSAGE the prisoner.

However, sending a message seems to be as difficult as introducing a spy. In fact, in the unlikely event that a diplomatic demarche would obtain authorization to present the message and the promise that it would be delivered to the prisoner, this would be useless because the mere fact that it would have to pass through seven levels of security, where it would be censored and mutilated, renders this possibility completely useless. In addition, such a LEGAL WAY (prior

**Rosario**

authorization) would impose the condition that the message be written in clear and precise language.

The enemy would then censor part of its content and transpose the terms to avoid a possible second encrypted message. And let us not forget that the secret of the hidden exit is as interesting for the prisoner to know as it is for the enemy to ignore it. And the first thing: what to say in a mere message to make the prisoner WAKE UP, to ORIENT himself, to understand that he MUST escape? No matter how much we think about it, it will become evident in the end that the message MUST BE CLANDESTINE and that it CANNOT BE WRITTEN. Nor can it be OPTICAL because the small window in his cell allows him to observe only one of the inner courtyards, where no signals can reach from outside the prison.

Under the conditions we have described, it is certainly not obvious how his KAMERADEN can solve the problem and help the prisoner to escape. Perhaps it will become clear if we bear in mind that, in spite of all the precautions taken by the enemy to keep the captive disconnected from the outside world, they FAILED TO ACOUSTICALLY ISOLATE HIM. (For this they would have had to keep him, like KASPAR HAUSER, in a soundproof cell).

Let us now consider, as an epilogue, the way chosen by the Kameraden to provide effective help, help that will 1. AWAKEN and 2. REVEAL THE SECRET to the prisoner, GUIDING HIM TO FREEDOM.

In deciding on an acoustic way to get the message across, the Kameraden realized that they had a great advantage: THE ENEMY IGNORES THE PRISONER'S ORIGINAL LANGUAGE. It is then possible to transmit the message simply, without double meaning, taking advantage of the fact that the message WILL NOT BE UNDERSTANDED BY THE ENEMY. With this conviction, the Kameraden did the following: several of them climbed a nearby mountain and, armed with an enormous conch shell, which allows the sound of the voice to be greatly amplified, they began to emit the message. They did so uninterruptedly for years, for they had sworn not to abandon the attempt until the prisoner was free again. And the message came down from the mountain, crossed the fields and the rivers, crossed the walls and invaded every corner of the prison. The enemies were at first surprised; but, as this language meant nothing to them, they took the musical sound for the song of some fabulous and distant bird, and in the end they became accustomed to it and forgot it. But what did the message say?

It consisted of two parts. First the Kameraden sang a CHILDREN'S SONG. It was a song that the PRISONER HAD HEARD MANY TIMES DURING HIS CHILDHOOD, back in the GOLDEN COUNTRY, when the black days of the war were still far away and perpetual captivity could only be a nightmare impossible to dream of. Oh,

What sweet memories were evoked by that melody! What spirit, however dormant it might be, would not awaken, feeling eternally young, on hearing once more the primordial songs, those which it listened to in the happy days of childhood, and which, without knowing how, became a distant and mysterious dream? Yes; the prisoner, however dormant his spirit might be, however much oblivion might have closed his senses, would eventually awaken and remember! He would feel the nostalgia of the distant homeland, he would verify his humiliating situation and would understand that only the one with infinite courage, with boundless intrepidity, could accomplish the feat of escape.

If this were the prisoner's feeling, then the second part of the message would be will give THE KEY to find the secret way out.

Note that we have said THE KEY and not THE SECRET EXIT. Because it happens that by means of the key the prisoner MUST SEARCH for the secret exit (a task that should not be so difficult considering the reduced dimensions of the cell). But after he has found it, he will have to complete his feat by DESCENDING to incredible depths, crossing corridors plunged in impenetrable darkness, and finally UP to remote summits: such is the complicated path of the enigmatic secret exit. However, he IS SAVED the very moment he BEGINS THE RETURN, and nothing and no one can stop him.

To complete the epilogue of the allegory, we only need to say a word about the second part of the acoustic message, the one that contained the key to the secret. It was also a song. A curious song that narrated the story of a sublime love between a gentleman and a lady already betrothed. Consumed by a hopeless passion, the knight had embarked on a long and dangerous journey through distant and unknown countries, during which he became skilled in the art of war. At first he tried to forget his beloved; but after many years, and having ascertained that the memory remained always alive in his heart, he understood that he would have to live eternally enslaved to the impossible love. Then he made himself a promise: no matter what adventures he might have to run on his long road, no matter what joys or misfortunes they might entail; inwardly he would remain faithful to his hopeless love with religious devotion; and no circumstance would succeed in diverting him from his firm determination.

And so the song ended: remembering that, somewhere on Earth, now transformed into a warrior monk, the valiant knight marches, armed with a mighty sword and a spirited steed, but carrying around his neck a pouch containing the proof of his drama, the KEY to his secret of love: THE RING OF

WEDDINGS that would never be worn by his lady.

Contrary to the nursery rhyme of the first part of the message, this one did not produce an immediate nostalgia but a feeling of powerful curiosity in the prisoner. On hearing, coming from who knows where, in his old native tongue, the story of the gallant knight, so strong and valiant, so FULL in his robe, and yet so sweet and melancholy, so inwardly RIPPED by the REMEMBRANCE OF LOVE, the captive was seized with that modest curiosity which children experience when they sense the promises of sex or sense the mysteries of love. We can imagine the prisoner pondering, perplexed by the enigma of the evocative song! And we can also suppose that he will finally find a KEY in that WEDDING RING ... which, according to the song, would never be used at any wedding. By induction, the idea of the RING, will lead him to search and find the secret way out ...

So much for the allegory. We must now highlight the existing analogies in order to draw important esoteric conclusions from them. In order that the analogical relationship may be clearly evidenced, we shall proceed according to the following method: first we shall state a premise with respect to the allegorical story of the "prisoner"; secondly, we shall state a premise referring to an analogous situation in the "lost virya"; thirdly, we shall COMPARE both premises and draw the CONCLUSION, i.e., we SHOW the analogy.

It is understood that we cannot present the TOTALITY of the correspondences without the risk of extending indefinitely. Therefore, we will only highlight those relationships that are essential for our purpose and leave, as an exercise of the reader's imagination, the possibility of establishing many others.

- 1 -

a - The "prisoner" is at the mercy of his guardians who keep him in perpetual captivity.

b - The "I" of the lost virya is a perpetual prisoner of "reason".

c - The "prisoner" and the "I" are analogous.



- 2 -

a - The "guardians" are the dynamic intermediaries, mean by the way, between the "prisoner" and the "outside world".

b - The "reason" is a dynamic intermediary, very poor, between the "I" and the "world outside" (in the lost virya).

c - The "guardians" and "reason" are analogous. (Let us remember that when reason elaborates a "law of nature", "mathematical principles" and "preeminent cultural premises" intervene).

- 3 -

a - The "guardians" use a "language of their own", different from the "language" of the "guardians".  
the prisoner's "birthplace", which the prisoner has forgotten.

b - The "reason" uses "logical structures", different from the original "primordial hyperborean language" of the lost virya, which he has forgotten (because of the strategic confusion).

c - The "proper language" of the guardians is analogous to the "logical structures" of reason. The "native language" of the prisoner is analogous to the "primordial hi- perborean language" of the lost virya.

- 4 -

a - The first environment of the "prisoner" is his "cell" in the tower, which thus contains him completely with the exception of the openings (door and window) through which the senses can only very weakly extend.

b - The first environment of the "I" is the "unconscious", which contains it almost completely with the exception of the "instinctive", "sensory" and "rational" spheres that intervene in the composition of behavior.

c - The "cell" of the tower is analogous to the "unconscious" of the lost virya. (As content of the unconscious we consider the "collective archetypes", especially: "mathematical principles" and "mythical elements").

- 5 -

a - In the "cell" there is a "barred window" through which the prisoner obtains a precarious but "direct" image of the outside world.

b - Establishing a permanent contact with the "I" is the "sensory" sphere, through which the "I" obtains a precarious but "direct" image of the external world.

c - The "lattice window" is analogous to the "sensory sphere" (or "the senses"). in the lost virya.

- 6 -

a - In the cell there is a "barred door" through which the guards enter, and with them the censored news, that is, through which the prisoner obtains an "indirect" image of the outside world.

b - The "I" can form an "indirect" image of the external world through "reflection", that is, the act by which "reasoned" information is received.

c - The "barred door" is analogous to the act of reflection.

- 7 -

a - The "prisoner's" cell is in a "tower" and this in a "walled" "courtyard". Surrounding the walls are deep "moats", and then other walls, and other moats; and so on until seven rounds of wall and moat are completed. The seven security circuits of this formidable "prison" are connected to each other by "drawbridges", "corridors", "gates", "drawbridges", "grilles", etc. Beyond the last wall extends the "outside world", the country of the enemy. In short: the "prison is a static structure that stands between the prisoner and the outside world.

b- Between the "I" and the external world there is a complex static structure called "culture". Reason, in order to make the information of the external world "reasonable", relies on certain elements of this static structure or "culture", for example, the "preeminent cultural premises".

c - The "prison" is analogous to "culture". Also: certain parts of the "prison", walls, moats, bridges, etc., are analogous to certain parts of the "culture", that is, the "preeminent cultural premises".

Commentary: Keep in mind that, in the allegory, both the "guardians" and the "prison" are intermediaries between the prisoner and the outside world. But the "guardians" are "dynamic" intermediaries (analogous to "reason" in the lost virya) whereas the "prison" is a "static" intermediary (analogous to "culture" in the lost virya).

- 8 -

a - Beyond the last wall of the prison extends the "outside world", that reality that can never be seen by the "prisoner" because the structure of the "prison" limits his movement and a permanent "guard" ensures that such a situation is maintained.

b - The "I" in the lost virya is skillfully submerged in the depths of the cultural structure, floating lost among its artificial and static elements and at the mercy of the implacable tyranny exercised by reason. The cultural structure completely surrounds the "I", except for a few cracks through which the "sensory sphere" peeps out. Beyond the cultural structure, as the object of the instinctive and sensory spheres, extends the "external world", the reality that can never be "seen" (in its truth; "as it is") by the "I".

c - The "outside world" beyond the prison is analogous to the "outside world" beyond the "cultural structure" that holds the "I" in the lost virya.

- 9 -

a - On a nearby mountain, the Kameraden try to help the "prisoner" escape from the "prison". To do so, they send a message, in their native language, using the acoustic medium. In this message there is a "nursery rhyme" to "wake up" the prisoner, and a "love song" with the "key to the ring" to find the secret way out and escape.

b - In an occult "center" called Agartha, the Hyperborean Siddhas try to help the lost viryas to break the chains that keep them subject to the material world of the Demiurge. To this end they charismatically send a message in the

The "language of the birds", using the "acoustic cabala". In this message there is a "primordial memory" to awaken and orient the virya, and a "love song" with the "key of the ring" to seek the center, conquer the Vrill and leave, as a God, the material hell of Jehovah-Satan.

c - Many analogies can be established between "a" and "b". We will only highlight the most important one: The Kameraden are analogous to the Hyperborean Siddhas.

We believe that the nine preceding arguments constitute an effective demonstration of the analogical correspondence that exists between the "allegory" and the "situation of the lost virya". But this is not all. We have reserved three components of the allegory (nursery rhyme; love song; secret exit) for a final analogical correspondence and to draw the final conclusion.

Since the validity of the existing analogical relationship has been evidenced in the preceding arguments, it will not be necessary to resort to the same method in the next commentary: we will consider the analogies mentioned as proven.

Let us now recall the reasons that led us to develop the allegory. We intended to show, in an analogical way, the method used by the Hyperborean Siddhas to counteract the action of "culture", the strategic weapon of the Synarchy. We previously clarified that the "inner cultural elements" are the true instrument that the Synarchy uses to keep the virya "lost", that is to say, in confusion. In this state the "I" is subjected by reason to the cultural structure, the source from which, finally, all mental activity is nourished. Thus it happens that the "I", i.e. the present consciousness, is "directed towards" the world "through" the cultural structure "by" reason; the result, as we have said several times, is a distorted image of the world and a state of psychic confusion which greatly hinders the "strategic reorientation" of the virya. Against this situation, the Siddhas, like the Kameraden of allegory, are ready to come to the rescue by "sending a message".

The main objective is to "circumvent all the walls" and reach the prisoner, the "I", with a message of double meaning: 1st to awaken; 2nd to orient. For that the Siddhas "transmit the message" charismatically, for MANY MILLENIUMS. Some hear it, awaken and leave; others, the most, continue in confusion. Of course, it is not easy to recognize the message because it has been emitted in the language of the birds ... and its sounds can only be perceived with the blood.

Is it clear then? The message of the Siddhas permanently resounds in the blood of the lost viryas. Those who do not hear it are either strategically confused or unaware of its existence, which is the same thing. But how should the charismatic message fulfill its mission? In two steps. In the first place, the Siddhas SPEAK, in the blood of the virya, of a primordial memory, of something that happened AT THE BEGINNING OF TIME when THE SPIRIT HAD NOT YET BEEN CAUTIVATED. BY THE GODS OF MATTER. How the Siddhas manage to do this is a very great Mystery, which only They can answer. This "primordial memory", the "nursery rhyme" of the allegory, has been induced for the purpose that it "activates" the virya's own blood memory, i.e., that it "feels" its Minne.

If such a thing happens, then the lost virya will experience a sudden "longing for another world", a desire to "leave everything and go". Technically this means that the "blood memory" has arrived "where the consciousness, the self of the lost virya, was"; usually upon a chakra. Such a contact, between the "I" and the Minne, takes place independently of cultural structure and reason; and that is the objective sought by the Siddhas. It was thus possible to reach the marrow of the "I" by the way of the blood; it will be then, in that fleeting moment, that the "song of love" will be heard.

Let us now speak of the second part of the message, which we have called, allegorically, "song of love. First of all, let us say that such a name is not capricious; for the Hyperborean Wisdom teaches that, FROM ITS ORIGIN IN THE PHYSICAL UNIVERSE, that is to say, from its synchronization with Time, THE SPIRIT REMAINS ENCLOSED TO MATTER BY A MYSTERY OF LOVE. When the memory of If the blood, activated by the first part of the message, OPENS A PATH (non-rational, non-cultural) TOWARD CONSCIOUSNESS, then the Siddhas SING THE LOVE SONG, they make the virya participate in the Mystery. If his blood is pure enough so that the charismatic message can be conscientalized, then the virya has the possibility to "orient himself" towards the origin and remain ultimately "awakened".

In the Second Dissertation (The Secret Societies and the Thulegesellschaft) we mentioned the "Mysteries of Antiquity" (of Osiris and Isis, of Mithras, of Dionysus, etc.) as possessors, in the historical past, of authentic remains of the Hyperborean Wisdom whose knowledge was only shared by members of a caste of initiated priests. It is worth clarifying here the difference between these "Mysteries" and the Mystery of Love, to which the second part of the message of the Siddhas alludes. In the first place, let us remember that the Mysteries of Antiquity were intended to perpetuate an esoteric knowledge by means of INITIATION, that is, they fulfilled an important function.

SOCIAL FUNCTION. In the second place, it must be borne in mind that these "Mysteries" are constituted because of the KALY YUGA, in an attempt to safeguard the Ancient Wisdom from universal decadence and the fall into exotericism. That is to say that from their origins the Mysteries of Antiquity have been LINKED TO TIME (historical), which was always their true foundation.

Contrary to the "Mysteries of Antiquity", the Mystery of Love is neither social (or initiatory) nor is it linked to any Historical Time, since its charismatic "transmission" is synchronistic and acausal, and, therefore, "always present". They only have in common the word "Mystery" but, as this fact may cause some confusion, we have thought it convenient to clarify it in order to rule out from the beginning any belief that the Mystery of Love may be (as in the "Mysteries of Antiquity") a mere esoteric knowledge that can be accessed by "initiation".

The Mystery of Love can only be revealed by the pure blood, inwardly, in a transcendent contact with the "I" that is realized without the intervention of cultural or rational categories. It is, therefore, an ABSOLUTELY INDIVIDUAL experience, unique to each virya. Whoever knows the secrets of the Mystery of Love is not an "initiate" but a TRANSMUTED, an "immortal Siddha" or, for a short time, an "awakened virya".<sup>1</sup>

The Mystery of Love is a personal discovery, and therefore unique to each virya, about the TRUTH OF HIS OWN FALL. No one can know this secret and remain the same. And no one, much less, would dare to speak about it once the Supreme Experience has taken place. On the contrary, many times the lips are sealed forever, the eyes blinded, the ears closed. Not a few hairs turn white, nor fewer minds sink into the darkness of madness. For only infinite courage can sustain, alive and sane, him who has seen the Deceit of the Origins and understood, at last, THE HOW AND WHY OF HIS FALL. The weight of the secret being so terrible, it is understandable why we say that there can never be in the world any hint of the Mystery of Love; and only someone irresponsible or mad would affirm the contrary. The Hyperborean Wisdom provides TECHNIQUES OF BLOOD PURIFICATION which have as their end APPROXIMATION TO THE MYSTERY. But the Mystery itself, discovered inwardly, is unique to each virya and NO ONE SHOULD SPEAK ABOUT IT.

---

<sup>1</sup> *Notwithstanding this clarification, we will continue, for convenience, to refer to the BERSERKIR of the S.D.A. as "initiates".*

The allegorical story of the prisoner has allowed us to expose in a simple way the method used by the Siddhas to guide the lost viryas. The charismatic message succeeds, if listened to, in "awakening" the virya by putting him in contact with his blood memory, with his Minne. Then, he makes him participate in the Mystery of Love, Supreme Experience that ANNULS, as we said, the cultural Strategy of the Synarchy. But we CANNOT know what the Mystery of Love consists of until we have lived it individually. We only have of it the GENERAL INDICATIONS left by THOSE WHO TRANSMUTED AND PARTIED. At

On the basis of such indications we can affirm that the Mystery of Love is experienced in SEVEN DIFFERENT WAYS by the viryas and that this is precisely the reason why the Hyperborean Wisdom foresees seven (secret) ways of liberation.

According to the way in which the Mystery of Love has been gnostically perceived, the path of liberation will be adopted; and that is why we usually speak of a "path of mutation" or "of lightning"; of a "dry path" or "path of the right hand"; of a "wet path" or "path of the left hand"; of a "path of strategic opposition" or "path of the warrior gnosis for the absolute return"; and so forth.

We shall not, of course, speak of all the ways of liberation, but of that which has a special bearing on our story, namely, the way of strategic opposition, which was followed by the initiates of the S.D.A. However, we cannot fail to mention that the Mystery of Love, revealed by the Hyperborean Siddhas, is the ancient basis of the tantric systems of Tibet, although at present such yogas have lost their gnostic meaning with the exception of TANTRA KAULA, which still contains part of the Wisdom.

In the allegory, the second part of the message was quite extensive because it also referred to the "other" ways of liberation that the Mystery of Love can "open". But the prisoner has found the key in the WEDDING RING and this means, analogically, that he has chosen the way of strategic opposition. The message has reached him "acoustically", that is to say, gnostically, and when he becomes aware of its content through the revealed key, he finds in the cell A RING, which allows him to OPEN THE SECRET EXIT.

The cell, according to argument 4, is analogous to the unconscious. But the "content" of the unconscious are the collective archetypes, mythical elements and mathematical principles; a "disguised" RING on the floor of the cell corresponds without doubt to A MATHEMATICAL PRINCIPLE, to a "disguised" archetype, i.e., unconscious.

The allegory allows us to understand, then, that the Siddhas, with their message, UNCOVER a MATHEMATICAL PRINCIPLE that remained unconscious, which we call the PRINCIPLE OF THE HEDGE. Hence:

- 10 -

c - The "ring" in the prisoner's cell is analogous to the "principle of the fence", a mathematical principle or collective archetype that remained unconscious in the lost virya and that the message of the Siddhas has UNCOVERED.

We have shown above that in the mental process that gives rise to the "scientific idea" of a phenomenon, elements from two main sources concur: "mathematical principles" and "preeminent cultural premises". This is seen mainly in the formulation of a "law of nature", which explains the behavior of a phenomenon by establishing causal relationships between aspects of it. Let us take a simple example: we wish to "measure" the side of a regular polyhedron. Here the phenomenon is a body in the form of a regular polyhedron. For this purpose we take the "graduated ruler", i.e. a flat surface on which the units of length are engraved and of which we are sure that one of its sides is perfectly straight. We make the zero of the ruler coincide with the "beginning" of the side we are going to measure. We now observe that the "end" of the side coincides with the number five on the ruler, and we affirm without further ado that "in the polyhedron the side measures five centimeters". We have performed, as will be seen, a series of subjective operations whose conclusions, however, can be confirmed by other observers; this possibility of verification is what gives weight of "law of nature" to the above-mentioned fact.

But it happens that, in the ruler, which we believe to be numbered, there are actually written signs that REPRESENT numbers, not numbers themselves. The numbers are mathematical principles proper to the structure of the brain, that is, subjective elements, which intervene in the act of "recognizing that the limit of the side coincides with the sign 5". If we say "it measures five centimeters" we are making the affirmation of an empirical quality: "there is a proportion (that is, a mathematical relation) between the length of the side of the polyhedron and the length of the terrestrial meridian".<sup>1</sup> This proportion is fixed or CONSTANT (= 5 CM) and constitutes a "relation between aspects of a phenomenon", that is, a "law of nature".

---

<sup>1</sup> *The CENTIMETER is equivalent to one hundredth of a meter and this is equivalent to one ten-millionth of a quarter of a meridian of the earth.*



The phenomenon (the polyhedron) was presented to us COMPLETE, integral in its manifestation. However, it is not possible to apprehend it in its totality; as soon as we observe it, ONE PART of it becomes eminent, standing out and standing out above OTHER ASPECTS. The UNITY of the phenomenon has been broken in favor of the PLURALITY of qualities that we are able to attribute to it. We distinguish TWO square faces and, on each face, FOUR edges and FOUR angles, and so on. Then we practice the MEASUREMENT of an edge or side and we establish a "law of nature": "the length of the side is proportional to the length of the terrestrial meridian and its ratio is 5 cm".

In this operation just described, thematic principles (when we distinguish TWO faces, FOUR edges, etc.) and "preeminent cultural premises" (when the face, the side, or any other quality became "eminent") have intervened. The two sources concur in the rational act of "relating" (measuring) aspects of the phenomenon and postulating a "law of nature" (it measures 5 cm) that can be universally verified.

We hope we have made it clear that the MATHEMATICAL PRINCIPLES (the ONE, the TWO, the SQUARE, etc.), being intrinsic properties of the mental structure, INTERVENE A PRIORI in the formulation of a law of nature. As for the "numbers" of the world, those that appear engraved on the graduated ruler, they are only CULTURAL SIGNS OF REPRESENTATION that we RECOGNIZE thanks to conventional learning. There were ancient peoples who represented numbers with knots or ideograms; presumably a measuring instrument consisting of a rod on which hieroglyphs have been engraved would mean nothing to us in principle if we could not "read" the signs, i.e., make the numerical representations.

The "principle of the fence", discovered to the consciousness by the message of the Siddhas, is also a mathematical principle and as such will intervene "apriori" in all phenomenal perception. The natural numbers (which are in the mind) allow us to "count" (one, two) the halves of that apple (which is in the world). The principle of the fence (which is in the mind) allows us to apply the "law of the fence" on that phenomenon (which is in the world). We have come a long way to reach this conclusion. Let us express it now in a general way: THE PRINCIPLE OF ENCIRCLEMENT MAKES POSSIBLE THE DETERMINATION OF THE LAW OF ENCIRCLEMENT IN ANY PHENOMENON AND IN ANY RELATION BETWEEN PHENOMENA.

But the principle of encirclement is generally unconscious; and only those who succeed in hear the message of the Siddhas can incorporate it into the conscious sphere. And only

They, the awakened viryas, will be able to apply the law of encirclement in a warrior strategy that ensures the return to the origin.<sup>1</sup>

As a last reflection with respect to the allegory, let us say that when the pioneer "pulls the ring" and discovers the secret exit, he is performing an action analogous to when "the awakened virya applies the law of the fence", according to the archimonic technique, and "opens" univocally and irreversibly a path to the Vrtil.

The method that the Siddhas use to counteract "culture", the enemy's strategic weapon, has been explained. They send their message whose purpose is to AWAKEN in the virya the memory of blood and ORIENT him towards the Vrtil, his "secret exit". For the latter, they induce him to discover the "principle of encirclement" and then to apply the "law of encirclement" in a hyperborean strategy.

The law of encirclement IS INFALLIBLE for the proposed strategic purposes and can be applied both individually and collectively. History abounds in examples of viryas who have applied techniques based on the Hyperborean Wisdom to immortalize themselves as Siddhas or to lead a people of pure blood towards collective mutation; as proof of these glorious actions there have remained numerous stone constructions that nobody understands in our days, because for that it would be necessary to possess a vision based on the principle of encirclement. A single glance at the megalithic constructions, or at Montsegur<sup>2</sup>, or at the K.Z.<sup>3</sup>, is enough for the awakened virya, knowledgeable of the archemonic technique, to correctly interpret the Hyperborean Strategy on which its construction was based.

Finally, let us say that whoever is aware of the principle of encirclement, HAS SUPEEDED the enemy cultural strategy and CAN REALIZE THE DOUBLE ISOLATION, OF THE SELF AND OF THE MICROCOSM.

---

1 *In book 4 it will be shown that the "law of the fence" is a law of the Psychosocial Strategy.*

2 *Montsegur - Castle on the Pog, in the French Languedoc, built by the Cathars according to the archemonic technique.*

3 *K.Z. (KONZENTRATIONSLAGER) "Concentration Camps" of the SS. They were not sinister prisons as the synarchic propaganda pretends, but marvelous "magic machines" to accelerate collective mutation, built according to the archemonic technique taught by the Hyperborean Wisdom.*

The principle of the fence will allow to fix the limits of the consciousness, isolating it from the preeminent cultural premises, and to move the "I" towards the "center" of the macro-cosmos, gaining its own time and space, that is, immortality: the micro-cosmos or physical body will have been transmuted into VRAJA, the incorruptible matter.

The berserkir (initiates of the S.D.A.) applied the law of encirclement in the Valplads by means of the archemonic technique. The archemone (here a ring of water) topologically divided the Valplads into two parts: an "outside", the Valplads proper, and an "inside" or "square".

When the berserkir has occupied the square and, by means of the "strategic opposition" applies the law of the encirclement on the archimona, the temporal desynchronization is produced and, if the opposition is sufficient, the final independence with respect to the time of the Valplads. But the time of the Valplads is "the immanent flow of the consciousness of the Demiurge"; to become independent of it, to have a "time proper to the microcosmos", means to be outside of any determination of "first" or "second order". The Demiurge has "momentarily" lost his capacity to act on the virya and this "moment", his own time, is taken advantage of to DIRECT, to ADVANCE, towards the origin. It is thus possible to conquer the Vril and transmute into immortal Siddha. But what happens if the center is not reached, either because purity has been lacking, or because one has feared to take the Great Leap? In the case of Rudolf II we have already mentioned the "strategic disadvantage" and described how it led him to madness.<sup>4</sup> And so, as a result of such risks, it is always warned that only he who possesses infinite courage and is stripped of all morals or dogma, will be able to employ the archemonic technique with a chance of success. But if one has sufficient courage and a total detachment from the "things of the world", it is always possible to perform the inverse operation of "synchronizing" with the time of the Valplads, although this operation implies a terrible leveling of forces. This is due to the fact that, during the "strategic opposition", a "SITZKRIEG" or siege war is posed, in which the enemy applies all the power of his Strategy on the archenemy, that is to say, against the square. Two Strategies confront each other; one, the Will of the Demiurge to maintain the material enchainment of the virya; the other, the Hyperborean Strategy of the one who has chosen, in order to undertake the return, to follow the path of strategic opposition with his archemonic technique. If the virya decides to continue to occupy the place while seeking the INNER EXIT, he must prepare himself to resist the ever-increasing pressure of the enemy. If he decides instead to "synchronize" and return to the Valplads, he must prepare himself to face a certain danger of madness, product of the consequent "archetypal maladjustment", from which only his blood purity can undoubtedly save him.

---

4      *We suggest rereading this part, chapter "Epilogue of Dr. John Dee's adventure".*

We have explained part of the archemonic technique; it is now our turn to explain what the strategic opposition consists of.

The archemone, as we have described it, that is to say, as it was used by the Ber-Serkir, is properly a "strategic fence". Upon it the initiate will project the "law of the hedge" giving rise to an action of war whose immediate purpose is to limit a space of the Valplads and remove it from the control of the Demiurge. Next, AS AN INEVITABLE EFFECT OF THE LAW OF SURROUNDING, the SITZKRIEG is posed and

the pressure of the enemy siege manifests itself with a certain intensity. If this pressure does not succeed in breaking the encirclement, the position remains "static". As this "pressure" means that a FORCE acts on the encirclement, it is convenient to draw an analogy with Newton's 3rd law which says "if a body exerts a force on another, the second always exerts on the first another force of the same intensity, but of opposite sense".<sup>1</sup> That is to say that, in the position of static equilibrium, the virya "contains" the enemy pressure on the archimona by exerting an equivalent pressure but of opposite direction; such is the analogical interpretation of the 3rd law. But as the enemy pressure is exerted from all the points of the Valplads, one may ask in what way can the virya OPPOSE an equivalent force AT ALL POINTS OF THE ARCHEMON? At first glance, one notices that this condition is quite difficult to fulfill for a virya whose physical body has no perimetral organs suitable for this purpose. However, although difficult, it is not impossible to find a solution to the problem. But naturally, such a solution cannot be rational.

In principle, let us answer the previous question: it is not strictly necessary for pressure to be exerted on all points of the archimony if we apply the hermetic principle "as above so below" or, better still, its magical consequence: "IN THE PART THERE IS THE WHOLE". Taking this principle into account, it is agreed that it is possible to "respond" to enemy pressure "from a part" of the archemone such that it represents, for strategic purposes, the same as "the whole". To fulfill this condition, John Dee, the Siddha who designed the archamone used by the S.D.A., proposed that the opposition be carried out only against a part of the Valplads, which would magically represent the whole, that is, the "world" of the Demiurge. In theory, it would be enough to define ONE POINT in the Valplads, since every point in space corresponds to a quantum of psychophysical energy U.E.V.A.A.C. through which the Demiurge manifests himself. But, in practice, man is not endowed to distinguish one point from another. Now, a psychophysical law says:

---

1 *FRANCIS SEARS - Fundamentals of Physics, Volume I, Page 18 - Ed.*

*Aguilar, Spain.*

1 E.E.U.V.A.C. + 1 E.E.V.A.C.U. = 1 E.E.V.A.C.U. MAJOR

esoteric relationship between archetypal atoms or quanta of psychophysical energy, which constitutes the true foundation of known profane laws of crystallography. In synthesis: a body, of homogeneous matter or not, can be taken as a MAJOR re-presentant of a simple S.V.A.C.U., that is to say, of a point in space. By a property of the U.E.V.V.A.C. -the indiscernible points- the Will of the Demiurgo manifests itself in the integrity of the body sustaining its material structure.

Based not only on concepts of the Hyperborean Wisdom but also on the Hyperborean Tradition, which narrates stories of many viryas whose strategies were successfully cultivated, John Dee recommended the use of STONE as the most suitable substance for strategic opposition practices. There is a great lack of knowledge about the hidden properties of stones, which are not simple solids but fluids; that is: flowing substances whose displacement occurs in an enormous lapse of time that we, because we have minimal vital time, are not able to appreciate. Their slow flow, of the order of millions of years, constitutes an inestimable quality because the creation of a "proper time" requires a temporal reference pattern (a "clock") whose period is as long as possible.

According to John Dee's criteria, a small stone placed in the Valplads IN FRONT OF A DETERMINED PLACE OF THE ARCHEMON, would be a suitable reference point to practice strategic opposition. But it should not be believed that the "small stone" can be "any" stone. There are psychophysical laws -originating in the sum of U.E.V.A.C. units- that state the necessity of a due proportion between the volume of the human body or microcosm and the volume of the stone that represents the macrocosm. This requirement leads to the fact that the stones used in hyperborean strategies are always of large volumes and, therefore, of a weight of many tons. How to reconcile such physical conditioning with the special characteristics of the A1 Strategy designed by John Dee? According to the English Siddha, the appropriate stone must be selected following the traditional rules of the Hyperborean Wisdom, a task that culminates in obtaining a giant rock, perhaps 500 or 1,000 tons. After this step has been accomplished, then the berserkir proceeds to CUT a small piece of rock which, for magical purposes, will fulfill the same role as the larger rock. Against that fraction of rock the strategic opposition will take place.

We do not think it is necessary to clarify that all these operations must be carried out under a special ritual atmosphere and following traditional but precise guidelines of the Hyperborean Wisdom.

According to John Dee's instructions, the berserkir selected a huge rock, part of a hill in the Bavarian Alps, which they roughed using flint hammers, since metal was strictly forbidden in this task. After bringing the rock to the "critical volume" proportional to the berserkir, they proceeded to tear out sixteen small pieces, no bigger than a fist, but suitable for practicing opposition.

The hill, with the major rock, was in the domain of one of the founding princes, i.e. in Dynastic lands; and although this fact provided sufficient security, great precautions were still taken to prevent anyone from tampering with the critical volume. If intentionally or accidentally the larger rock were to be fractionated, the strategic opposition would be nullified with the consequent risk of returning to the Valplads in STRATEGIC DISADVANTAGE. It is understood then that the major rock was carefully concealed and that all sorts of sinister legends were woven about that hill in order to scare away the superstitious inhabitants of the area.

As for the minor rocks, the berserkir transported them to the place where the arquémona was located and deposited them, as we have said at the beginning of this "course of action", in sixteen trunks, together with strange warrior vestments. Although the place of the ceremonies changed several times over the centuries, the arrangement of the archamone and other ritual elements always conformed to the design we have already described.

The minor rocks were called LAPIS OPPOSITIONIS<sup>1</sup> or simply LAPIS by the berserkir. The part of the archimona in front of which the "lapis oppositionis" was deposited was called FENESTRA INFERNALIS or FENESTRA<sup>2</sup>. The archimona had to present in the "fenestra" an irregularity, something like "saw teeth", as John Dee had indicated. This irregularity represented the site of maximum approach to the Valplads, a quality that would become evident when the berserkir applied the law of encirclement and initiated the strategic opposition. To dimension the fenestra, ancient principles of the Hyperborean Wisdom were also to be followed.

As a summary of what has been said, we could now look at a sim-  
of the crypt. Afterwards, we will have to return to the berserkir

---

1 *OPPOSING STONE*

2 *INFERNAL WINDOW*



## CRIPTA SECRETA

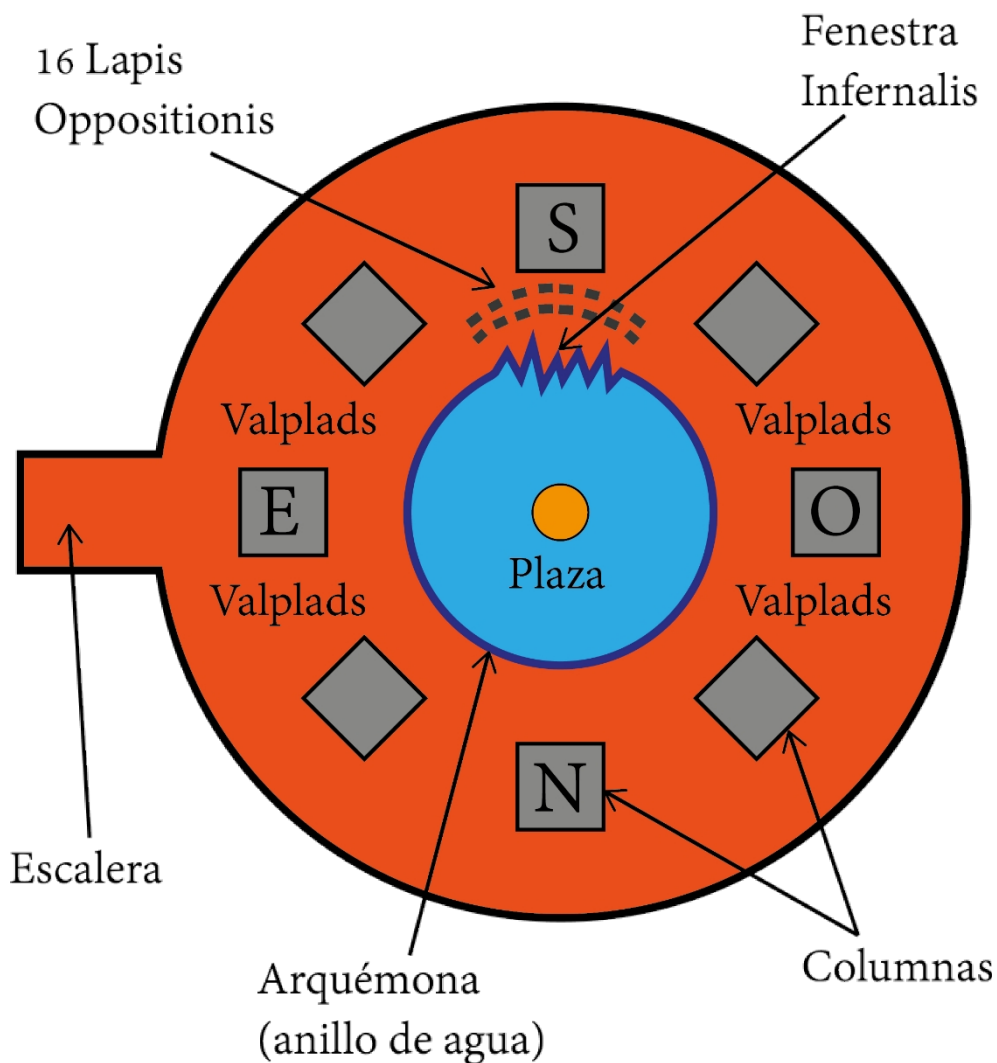

who, already dressed in their new clothes, get ready to begin an initiation ritual.

Only a few minutes had passed, but the berserkir showed a remarkable transformation. On the tables and hanging from iron brackets on each column were the rich courtly robes that the nobles wore at the time of the

descend into the crypt. They wore, on the other hand, a curious warrior costume that could not be classified with certainty as belonging to any historical people, although the general appearance was undoubtedly Nordic. They wore a doublet of fine leather and, over it, a scaled coat of mail (LORICA E SQUAMATAE), forming an ensemble similar to those that the Roman centurions called "CATAPHRACTA". They wore leather sandals (CALIGAE) and a conical helmet with a nasal protector, also made of leather, studded with octagonal gold studs. The dagger and sword hung from a thick belt in simple leather sheaths. The latter was made of iron with an ivory hilt, at the end of which the two small "HALLSTATTICOS" horns<sup>1</sup> showed the prodigious antiquity of such a "model" of weapon: it was not the CROSS, yet, but the very ancient TAU, the rune of THOR, the magic sign that characterized it. On the left forearm they had fitted the shield with three convex sides, passing the hand through two back straps; with the same hand they each took their lapis oppositionis, the lesser stone. In the right hand they firmly wielded the double-edged axe of black and shining iron.

The only two ladies, similarly dressed, in no way detracted from that fantastic display of warrior mysticism. They were distinguished from them only by some of the arrangements proper to their sex; otherwise, the same courageous resolution shone in their eyes as in the rest of those present. The sword, somewhat shorter, was of the same "hallstättic" type as the others, but the dagger was not at the waist, but hung from the neck in the manner of the Viking women. They also wore a leather helmet, from which their hair fell, divided into two braids, each topped by a golden fibula. Finally, perhaps the most striking detail of the ladies' costumes were the two iron hemispheres that, apart from protecting the breasts, clearly revealed their qualities as Amazons.

Almost at the same instant they all finish dressing and, without saying a word, they remain standing by their column, staring fixedly at the archimage. It is only a moment, in which each one thinks of the terrible ordeal that will immediately follow. They are fifteen Berserkir Siddhas engaged in a war of Gods and Demons, in a war that most men cannot even imagine, for if they did, they would surely lose their minds. But what are "men": lost pasús and viryas? Metaphysical warfare is forbidden to them,

---

1        *From "HALLSTATT", a culture belonging to the first European Iron Age for anthropology and archaeology (1200-700 B.C.). According to the Hyperborean Wisdom, there are traces of a much older heritage here, dating back to Cro-Magnon man.*

but also the possibility of salvation, of awakening, of gaining immortality, of to return to the divine origin... Oh, what a painful situation that of the captive spirits!

And how abominable and hateful to the AWAKENED EYES is the captivating Demiurge!

The eyes of the fifteen berserker flash with anger: It is as if they were all thinking the same thing and a roar struggled to come out of their throats: There can be no truce with Jehovah Satan! He who has engendered "chosen races" inflated with diabolical pride, who has drawn up Plans counting on the pain of the chained, who has made a pact with the Traitor Siddhas of Chang Shambala and placed them at the head of all his infernal legions, He CANNOT BE FORGIVEN BY MAN.

The Berserker's chest heaved rhythmically in a simultaneous breath, while a dull, essential, indescribable fury seemed to ignite every atom of the blood that coursed through their veins. The BERSERK FUROR was soon a palpable energy that radiated from the Siddhas and polluted the whole of that realm they called Valplads. Soon the atmosphere became DENSE and unbearable, as if reality, subjected to invisible but tremendous tensions, was about to explode. A climate of restrained violence emanated from the berserker and collided with the halo of malignity that, little by little, was coming out of every corner of Valplads. The primordial confrontation, the conflict of the origins, was once again raised. And that DENSE ATMOSPHERE, irresistible to the common man, constituted on the other hand the eternal, irrefutable proof of the hyperborean lineage. There, in that underground crypt, was taking place the most ancient miracle, which is also the most terrible secret: THE MYSTERY OF THE BLOOD THAT TRANSFORMS INTO FIRE. The fifteen Berserker Siddhas had taken the consciousness towards the charismatic and racial center, towards Christ-Lucifer, and the force of the Vril had filled them, trans-muting them into Divine Hyperboreans, that is to say, making them become that which they already were, but which they generously forgot for seventeen and a half years to live in the Valplads and serve the race. Now they were all on the move toward the archimage. It had been only a few minutes since they had changed their clothes, but the metamorphosis was so complete that not even their closest intimates would have recognized them. Only another Siddha, another berserker, or some Demon of the Synarchy, upon seeing the fierce image of those timeless warriors, who advanced howling and roaring, wrapped in a whirlwind of fire, would have given the right qualification: that was, without a doubt, Wotan's elite.

The berserker walked with firm steps the distance that separated them from the fenestra. They did so along the Valplads, following the curve of the water ring

of the ar- quémona, until they reached the "sawtooths," the irregularity that characterizes

to the "fenestra infernalis". In front of that part of the archimona, on the floor of the Valplads, there were sixteen runes of silver, carefully inlaid. All the same, they corresponded to the sixteenth letter of the FUTHARK alphabet, that is to say, to the rune SUN, whose sign is similar to lightning.

The Castilian, before anyone else, with a swift movement, placed her lapis opposi- tionis on one of the runes and, taking a prodigious leap, entered the archimage. Once in the "square" he fixed his eyes on his lapis while applying the law of encirclement to the water ring. As the opposition on the lapis increased and the law of encirclement isolated the square from the Valplads, the Castilian's body desynchronized its biological and atomic clocks from "external time" to stabilize itself in a "time of its own", controlled by the consciousness of the microcosm. Quickly she began to emerge like a brilliant vapor from the water ring, while the other berserkir, also deposited their lapis oppositionis on the runes, were preparing to enter the enclosed square. The castellan, without distracting herself for an instant from her operation, pronounced a word in the Enochian language as a sign. Instantly one of the berserkir answered "FREYR", which was the password agreed upon seventeen years before and, without waiting for an answer, jumped over the "teeth" of the fenestra into the square. Again, the castellana repeated the "santo y seña", giving place to the entrance of a second one, and so it continued until all had penetrated through the fenestra after pronouncing the same password. According to the tradition in the Dynasty, since the times of John Dee and Wilhelm von Rosemberg, if any blood impurity plunged the berserkir into strategic confusion during the seventeen years that intervned between one ceremony and another, it would be very difficult for him to pronounce the password CORRECTLY. And this error would be paid with the life because the Guar- dian of the Plaza, in this case the Castilian one, would NOT OPEN THE FENESTRA, subjecting the imprudent to a space-time UNLEVEL that would destroy him as soon as he tried to take the leap.

It is worth noting that the word uttered by the Castilian in the language of the birds, would sound in any PROPHANE EAR as if it heard THE CROW CALL. And this is so because no living being, whose blood is impure with cowardice and fear, can ever understand the cry that the Aces give from Valhalla to the warriors of Wotan. Instead, they will ALWAYS BELIEVE "THAT THEY HEARD THE CALL OF THE ROOSTER".

When the last of the berserkir had entered the enclosed square, the voice of the castellana was heard once more pronouncing the santo y seña. No one responded to the musical word; but an entirely new event began to unfold in one part of the crypt. Behind the south pillar, in the circular gallery, a figure that until

then had remained completely immobile began to sit up. He was a young member of the Dynasty who, since forty-eight hours before, had been keeping vigil at arms awaiting the moment to prove his courage and his purity of blood. For four long years he had been initiated into the Mysteries of the Hyperborean Wisdom by his uncle and tutor, one of the berserkir counts, with a view to filling the only vacant seat in the Einherjar or S.D.A. He was sixteen years old and, although his profane name was William Egon, the Kameraden of the S.D.A. called him, esoterically, WILDE JÄGER<sup>1</sup>.

From the moment the berserkir descended the stone staircase, and for the duration of the warrior preparations, the young Wildejäger remained unmoved, awaiting his turn. It was forbidden for a mere "apprentice-at-arms" to set eyes on the square during the occupation ceremony; but he had been duly instructed on how to behave afterwards. Therefore, he was aware that there was no longer any possibility of turning back: the secret door was locked and the key was in the possession of the castellan; and if the berserkir found him ALIVE in the Valplads, at the end of the ritual, they would proceed to execute him. Without any consideration for his kinship. When the warrior has transmuted into a berserkir and the force of the Vril has ignited the blood with icy fire, he reaches a degree of consciousness that is beyond cultural or moral considerations. The berserks gangr, the fury of the berserkir, recognizes no other merit than pure blood; whoever confronts a warrior of Wotan's elite without experiencing ESSENTIAL HOSTILITY or, what is the same, experiencing FEAR OF ORIGIN, will be immediately attacked by him, WHOEVER HE IS, and surely destroyed.

But Wildejäger was not afraid. With a determined step he crossed the gigantic pointed arch and went around the south column until he was between it and the fifteen lapis oppositionis. When he arrived there, he stopped abruptly, not because the ritual indicated it, but because of the strange scene before him. Stupefied, he observed that, following the perimeter of the arquémona, an enormous column rose upwards. It was a cylinder impenetrable to the sight that, in its lower part, up to the height of a man, flamed and seemed to be of fire; but that, in its middle and upper part, lost density and was like a gray smoke that was becoming blacker and blacker until it was lost in the heights. Just as Wildejäger looked up, he saw with surprise that instead of the ceiling of the crypt he was looking, against all reason, at a starry firmament. In reality, it was only a portion of the sky, as he recognized almost unconsciously, where he could make out, in an impossible perspective, BEYOND THE BEAR, an unknown constellation composed of a group of stars.

---

1            *WILDE JÄGER = wild hunter.*

of five green stars arranged in a circle. In the center of the five stars he thought he recognized a smaller circle, of a black so intense that it contrasted with the darkness of the cosmos. It was a kind of black sun, or at least it seemed so; of this he could not be sure, for the brightness of the green stars twinkled rhythmically and their reflections converged on that black center, merging into a ray, which crossed among countless stars, until it stopped very close to Wildejäger's astonished gaze. The green ray was entering FROM BEHIND a star well known to men: the one that goes out last in the morning when the sun spreads its hot light, and which the Romans called Venus. Wildejäger knew this immediately because he saw, engraved on the star, the sign of the ANIS, the same hyperborean sign of the Lords of Venus that he had painted on his shield.

If Wildejäger had eaten in recent hours, he would have thought he was under the influence of a drug; but he had been watching his weapons for forty-eight hours while fasting, according to the ancient ritual of warrior initiation adopted by John Dee for the members of the S.D.A. So, without quite understanding how he had been able to SEE and KNOW all this, the young man looked away from such a disturbing cosmic image and concentrated on his next steps.

For forty-eight hours earlier he had been dressed in a warrior's outfit similar to that worn by the thirteen male berserkir. The only difference was the presence of a CORNUS hanging from his neck by a golden cord. In the right hand he carried the double-edged axe; and in the left, a lapis oppositionis, together with the triangular shield that he wore on his forearm.

Seeing an "S" rune gleaming uncovered among the fifteen lapis oppositionis, he approached it and placed his own stone on top of it, and then, in a final glance, he looked out over the Valplads. He would never again be the same or see reality as ordinary men see it, a mixture of pasu and lost virya; he was aware of this and it did not worry him at all; he was only "saying goodbye", not without a certain irony, to his present blindness and stupidity. His unspeakable audacity to "stand up to the world" met with an immediate response; and a halo of evil began to fall away from things, more and more intensely, until it became a fetid and corrupt miasma that threatened to surround and drown him. However, Wildejäger, in his years as an "apprentice-at-arms," was taught how to "close his senses"; and now, faced with the ordeal of resisting the onslaught of a world that exchanges its inert and peaceful "appearance" for other, more aggressive and frightening illusions, he shows the assurance of an expert warrior. Indifferent to the palpable malignity that surrounded him, he fixed his eyes on the fenestra and, raising the CORNUS to his lips, blew violently. A low, hollow, low sound lasted for a few seconds,

becoming hoarse as it slowly died away. It was undoubtedly a signal of a call. But the URG sound emitted by that marvelous instrument had other properties as it evoked in the listener ancient hunting scenes, carried out by unknown races in remote and forgotten forests. The sound of the COR-NUS transported and made participate in that climate of fierce agitation that produces the pursuit of prey, irresistibly awakening the primordial instinct of the hunter. This effect was sought after because the initiates of the S.D.A. affirmed that "from a hunting instinct it is much easier to produce the berserkir fury". For this reason they had designed a special instrument, according to the principles of the acoustic cabala, which resonated with the BIJA or universal acoustic root "URG", which has the double effect of EVOKING the hunting instinct and of CALLING. The question now arises, call... who?

We have touched with this question the deepest meaning of the ritual action, for the fact of CALLING as a previous step to the condition of BERSERKIR, that is to say, of initiate of the S.D.A., by the way of strategic opposition, alludes to the Mystery of the Rescue. We have already said, on several occasions, that the Hyperborean Wisdom indicates seven ways of liberation. However, there is an EIGHTH WAY, called EXCEPTIONAL, of which nothing can be taught or learned, which is why it is rarely mentioned. The Hyperborean Wisdom says nothing about it; and it is the Tradition which affirms that "every lost virya can be RESCUED INSTANTLY if he makes the CORRECT CALL, EVEN BEFORE UNDERTAKING ONE OF THE SEVEN SEVEN SEVENTH WAYS".

The Tradition, although it does not provide esoteric details about this eighth way, uses a "classical analogy" or NIA to expound the Mystery of Rescue. The NIA tells the story of a warrior who, during the actions of a terrible war, is shipwrecked and becomes trapped in enemy territory. At first he is overcome by despair, but then, because of the great suffering that his shipwrecked condition imposes on him, he resigns himself to his new situation, without being able to prevent bitterness from settling permanently in his soul. He spends a very long time in this state, until one day, overwhelmed by loneliness, he entertains himself in REMEMBERING the happy days of his military training. It is then that something he had completely forgotten comes to him: he sees himself at the moment when he was closing his deal as a warrior; and he sees his military instructor who tells him: *"every soldier has the RIGHT TO BE RESCUED"; no matter where he falls or how dangerous the situation is; HIS CHIEF WILL NEVER ABANDON HIM; IF HE CALLS YOU, HE WILL COME IMMEDIATELY AND YOU WILL BE EVACUATED; BUT DON'T FORGET IT: YOU MUST CALL HIM, YOUR BOSS, FOR HE WILL RECOGNIZE AND RESCUE YOU QUICKLY.*

*If he does not do so, he has only the alternative of attempting to evade on his own.*



*account, following secret techniques. The theater of war is too vast and complex for ANYONE OTHER THAN YOUR BOSS TO RECOGNIZE IT AND COME TO YOUR HELP. REMEMBER: CALL HIM".*

The NIA concludes with the image of the shipwrecked warrior who is immediately rescued by his chief, who promptly comes at HEARING THE RIGHT CALL. Such is the classic analogy of the Mystery of Rescue, the eighth exceptional way that confirms the correctness of the other seven. The call that Wildejäger made with the CORNUS symbolically alluded to the possibility of receiving immediate rescue, even before embarking on one of the secret ways.

In front of Wildejäger, the enormous pillar of fire rose from the archimona and was lost in the cosmic darkness. The sound of the CORNUS had not yet died away when the voices were heard, coming from some undefined part of the archimona:

*A VOICE: - Attention berserkiren! Someone is approaching the fenestra infernalis!*

*ANOTHER VOICE: - Tell me, Guardian of the Fenestra, do you know the bold pilgrim? is he friend or foe?*

*THE FIRST VOICE: - Yes, I know him. He's the one they call William Egon in the Valplads. He seems to have bold intentions.*

*THE SECOND VOICE: - Guardian of the Fenestra, call the pilgrim to a halt and ask him how we should interpret his audacity!*

*THE FIRST VOICE: - Stop! Where are you coming from and where are you going?*

*WILDEJÄGER: - I do not know exactly where I am because I have been infallibly deceived. I wish to flee from hell and for that I have called MY BOSS; but I am impure of blood and that has affected the quality of the call. I am left to my own devices and all that is left for me to do is to orient myself and move forward, fighting head on against the enemy. That is why I request permission to enter your square, because from that LIBERATED LAND I will be able to direct my sights, orient myself and fight.*

A MURMUR OF SEVERAL VOICES CAN BE HEARD, EITHER APPROVING OR CONDEMNING WILDEJÄGER'S AUDACITY. Finally:

THE FIRST VOICE: - (pronounces the sign in the Enochian language)

WILDEJÄGER: - *FREYR!*

THE FIRST VOICE: - *The fenestra is open. You have permission to enter the square. Now show your courage and fearlessness!*

When Wildejäger heard the authorization, he readied his shield, raised his hacha, leaving his arm ready to unload a blow, and leaped, over the lapis oppositionis, directly into the column of fire. Instantly he disappeared from sight, for the igneous vapor that gushed from the archemone, terribly DENSE, absorbed him completely.

Any observer who knew the NORMAL arrangement of the elements of the crypt would have believed, at that moment, that Wildejäger should land from his jump inside the archemona, that is to say, in the square. But the archelement was a powerful magical instrument, activated then by the law of encirclement applied by the berserkir, and that is why things happened differently: between the square and the Valplads there were not a few inches, as common sense seemed to indicate, but that immeasurable distance that the berserkir called HEL!

No sooner had Wildejäger entered the DENSE AIR than he found himself floating in a boundless space, dimly illuminated by a twilight that no one could tell where it came from. In front of him, but at a very great distance, a small circle glowed with a golden glow and seemed to be moving farther and farther away. Sharpening his eyes, he discovered, not without effort, that it was the archimona itself, with the enclosed square he intended to enter. Without thinking, he started to run in that direction, without thinking how it could be that he could have set foot in the middle of the space; although an inner feeling, which he was trying to cancel out, told him that all this was the product of a dream. Immediately, when the first claw tore shreds from his shoulder and the blood began to flow, all doubt was dispelled and the truth became present in all its dreadful reality: he was in a world of madness, WITHOUT POINTS OF REFERENCE, ready to face dangers a thousand times more terrible than those of the despised Valplads! The ONLY possibility of salvation now was the archimona, just a shining dot in the distance. If he lost sight of it he would never be able to find it again; and his situation would be much worse than before, lost in that twilight hell. With a blow of his axe he cut down a polyp-shaped monster that was blocking his way and ran desperately in the direction of the archimona, dealing axes left and right.

It is not our intention to describe in detail the filthy creatures that haunt Hel and that, adopting all sorts of repugnant forms, present themselves with infamous and aggressive intentions trying to cut off any daring intruder. If anyone wishes to delve into such blackness, they can consult the Egyptian "Book of the Dead" or the "Tibetan Book of the Dead" (Bardo Thos Tol) or, in any case, read the tales of H.P. Lovecraft.

At first Wildejäger managed to advance a little, especially thanks to the effectiveness of his armed arm and the ANIS sign on his shield, which frightened the demons who did not dare to attack from his left. However, it soon became clear that it was impossible to keep that advantage, for a cloud of disgusting little creatures, no bigger than a hummingbird, but eager to suck blood, rushed at his wounds, while legions of hideous and evil creatures fought among themselves to take part in the attack.

Step by step Wildejäger moved, dagger in his left and fearsome axe in his right, severing tentacles and claws and splitting nightmarish heads with bloodshot eyes, whose gazes conveyed the infinite, essential hatred that the Demiurge manifests for the hyperborean race. Covered in blood from head to toe, practically blocked by the infernal hosts, Wildejäger suddenly looked away from the combat and desperately searched for the figure of the archmage.

Then he saw with horror that a bright dot was far away, UPWARDS, moving away at great speed! He was falling, without any doubt, into a dark abyss full of enemies, about to perish irretrievably, and to fall again, after death, into a definitive spiritual loss. Wil- dejäger thought he would sell his life dearly and die without retreating an inch; but now he saw that the retreat was taking place IN DESPERATION OF HIMSELF, by virtue of the fall into the diabolical precipices. This fact shocked him vividly and awakened in him, like a flash of lightning, the memory of his berserkir instructor. Yes, the old Prussian count had wisely done that day, two years before, while teaching him the rudiments of berserkir fighting, employing MUDRAS of war and pronouncing MANTRAS of power<sup>1</sup>. That time the instructor had told him, now he remembered it clearly: "nothing and no one can stop a warrior of Wotan's elite. No demons or accidents can stop him if his blood is pure enough. If an abyss stands between him and his goal, the berserkir saves him.

---

1 *MUDRA: gesture or position with magic connotation. MANTRA: word or sound with magical connotation.*

DEEPER THAN THE ABYSS".

In an instant Wildejäger grasped the meaning of those words and, feeling his blood begin to burn until it ignited in a blaze of primordial rage, he uttered the most terrible cry those infamous beings had ever heard. The cry "deeper than the abyss" was a forbidden name, howled with such ferocity that along with the sound the rabid foam spurted from the warrior's mouth. The eyes were sparkling with a hatred as irreducible as that which pulsed in the eyes of the demons, and suddenly, transformed into a fiery figure, flaming to the rhythm of that bestial howl, Wildejäger was, in another sense, more frightening than the demons themselves. The demons must have sensed this; for, starting a savage retreat, they promptly left the way open, through which the already transmuted berserkir rushed like an arrow. Shout and speed were one; and soon the golden disk of the archimona was so near that he could behold its true aspect, that which the law of encirclement projected by fifteen mighty minds bestowed upon it. He saw clearly that a massive-looking stone construction rose up following the contour of the archimona; it had only one opening, in the form of a loophole, in the place of the fenestra; the roof was a vault perfectly adjusted to the cylindrical perimeter of the wall, which served as a rampart or fortified tower, whose stones were so perfectly cut and assembled that it would have been useless to look for the slightest chink between them.

But he could not see much more; for the end of the scream coincided with the end of the jump. Indeed: the horrifying roar was still reverberating in his throat when Wil- de j ä g e r rushed through the embrasure into the strange fortress. He landed standing on the side of the square, looking fierce and roaring and constantly changing his mudra in a whirlwind of axes, stabs and stabs. He was quickly surrounded by the fifteen berserkir, who deftly parried his blows while trying to calm the brave Wildejäger.

What happened next is worthy of being narrated in detail; for it will be difficult for synarchized minds to believe ... and therein lies its merit. Hardly had Wildejäger recovered from his fit of berserkir fury, having just lowered his armed arm in the presence of his relatives, when the fist of one of them crashed violently into his chest. He staggered from the impact and fell backward without being able to avoid it, for a well-aimed leg locked with his own in a dexterous stride. However, he did not hit the ground. Several berserkir behind him had stealthily spread a cloak, holding it tightly at the edges, which hollowed out and trembled as it received the helplessly falling body. They then proceeded to pull the cloak taut horizontally, causing Wildejäger to fly away to

The berserkir were all laughing and jeering at the young warrior's feat. The mantling was done amidst the laughter and jeers of all the berserkir who exteriorized in this rude way the wild joy they felt for the feat of the young warrior, who had crossed the Hel giving "a cry deeper than the abyss". And it was also the baptism of comradeship to the newcomer who joined the golden circle of the Einherjar.

- *Ha, ha, ha, ha,*" laughed the Castilian woman, unrecognizably transformed into a Lady of War, "*You have become a bear, Wildejäger! A furious, roaring young bear!*

- *Yes,*" said another of the warriors, "*it is worthy of a berserkir to force a hundred cohorts of demons to flee, ha ha ha ha.*

And so on and so forth. They made exclamations of admiration and laughed without ceasing to keep their hands off the heroic young man who, far from being disgusted, also laughed out loud, rejoicing at the barbaric joy.

And now that we have seen this curious scene, it is worthwhile to make a brief reflection. Think of this reception that the berserkir paid to the one who stood beside them AS THEIR EQUAL, after accomplishing the incredible spiritual feat of transmuting himself into an immortal Siddha. Think of this reception full of joy and sincerely manifested joy and compare it with the abject submission demanded by the White Hierarchy from its unhappy "initiates". A "synarchic initiate" must be ready to kneel down and kiss the effeminate robes of the Masters of Wisdom and Gurus who will then gently rest their holy feet on the humble head and piously plunge it into the mud of slavery. Think of these two attitudes, compare them and draw a conclusion; then you can choose which path to follow. We, however, will say it here. What an insurmountable difference between the beautiful picture of the berserkir fiercely confronting the enemy to win his right to spiritual immortality, and after the battle laughing happily with his Kameraden, without confrontation or secrets, without hierarchy, all united by a code of honor that only obliges to keep fidelity with the One who is beyond all evil, What a difference, we say, between these gallant warriors and the somber initiates of the Synarchy, organized on the basis of a scale of Terror that humiliates them with a thousand perversities and demands of them very few initiatory "tests", of which perhaps the most picturesque is the defloration of the ass through which they are all forced to pass, with greater or lesser joy!

But let us return to the archemone and contemplate the culmination of the initiation.

Wildejäger berserkir.

From inside the fortress, in the square, it could be seen that the walls of the enclosure followed a perfectly octagonal plan. On each of the eight walls, a glowing sword provided ample illumination. And even if from the outside Wildejäger saw that the ceiling was a massive stone vault, when he looked up he could clearly see a portion of the starry firmament, in which five green stars stood out strangely, forming a circle around a black sun, barely perceptible ... Precisely FROM THE SKY three disturbing Presences had entered a few seconds before.

The Siddha Baldur, one of the divine Aces, came in representation of Wotan to celebrate the MINNEDRINKEN, the ceremony where the mead was drunk and where it was the Gods, and not the weak men, who VOWED. On that occasion Baldur would commit himself to charismatically guide the future steps of Wildejäger who, by his own decision, would return with the remaining berserkir to Valplads to continue, for another seventeen and a half years, working in the EINHERJAR for the good of the race.

Accompanying Baldur were the Walkirias SIGUNE and EXUAZ, one carrying the boot of mead and the other the glasses of transparent gold. After distributing the glasses, into which Sigune poured generous doses, the sixteen berserkir and the Siddha Baldur proceeded to shout HRIM! as they clinked the glasses; then they drank the contents with respectful circumspection and then, each one, smashed the glass with an accurate blow of the axe. No one could ever drink from these cups or in any magical way upset the sacred meaning of the Minnedrinken. Exuaz picked up the destroyed cups, for that marvelous metal, obtained by alchemical processes, could not be lost; in Valhalla, skilled smiths used it to build other utensils.

We must be cautious in relating those parts of the Secret History of the Thulegesellschaft in which the divine Hyperborean Siddhas intervene. If we were not to do so, we would run the risk of profaning the sublime experience of accessing the Presences and, what is perhaps worse, we would give the unsuspecting reader a wrong, novel or unreal idea about the TRUE aspect of the Siddhas. This is, without a doubt, the MOST TERRIBLE that can be imagined; and only the very brave manage to come face to face with those who represent THE ESSENCE OF THE RESOLUTION. A Gral Knight or a Kshatriya or a berserkir warrior or a Jaina of Japan or a Kaula initiate, etc., may be prepared for such an encounter.

But who else is willing to rebel against the tyranny of the Demiurge and to undertake the inverse route indicated by the Siddhas: few, very few indeed. And if the majority of viryas remain in confusion, seeing the world through the cultural mask, dominated by the Synarchic Strategy, we will not be so naive as to believe that further desecration of the Mysteries would be of any use. But neither can we fail to affirm that the Presence of the Hyperborean Siddhas constitutes a REAL experience for those who have sufficiently purified their blood, and not a "symbol" or a mere literary figure. That is why we will not add more details about the subsequent events that occurred after the Minnedrinken, up to the departure of the Siddha Baldur and the two Walkirias.

"Minnedrinken" is only a Germanic denomination for the very ancient ceremony in which man, initiated or transmuted, is given to share for once the drink or food of the Gods. In India the sacred drink is called AMRITA; in Persia AHOMA; in the Greek Olympus AMBROSIA; for the ancient Aryans SOMA; for the Germans HYDROMIEL, etc.; but in all cases it is the same thing: the transmuted man drinks a drink that is also transmuted, changed in its original characteristics and then endowed with special powers. It is commonly believed that the sacred drink is a drug, consumed by priests and initiates in order to "open" certain transcendent channels by means of narcosis or intoxication. This absurd belief implies reducing, for example, the berserkir warriors to the level of miserable and vicious "hippies". It is the Synarchy that uses narcotics and intoxicants to undermine and destroy the body of its "adepts" who seek enlightenment through a "journey". Hyperborean Wisdom, on the contrary, is obtained by purifying the blood, not by poisoning it. The degrees of transcendence reached by an awakened virya will always be permanent, never transitory and ephemeral like those gained by means of drugs. If this is so, what then is the true role that the sacred drink plays in the set of secret techniques of spiritual liberation?

In the first place, mead, as well as soma or any other sacred drink, possesses the property of FIXING the memory of blood that has been previously attained by means of purification techniques or by adequate strategic attitudes. In the second place, let us say that, for this reason, the sacred drink is never drunk a priori from the transcendent experience: it would not make sense because it would run the risk of FIXING morbid states, which, permanently bound to the consciousness, would end up dragging whoever proceeded in this way to madness. As a synthesis and clear example of what we have said, it is worth remembering that the medieval Germanic troubadours, the MINNESÄNGER, celebrated the ritual of the MINNEDRINKEN during which they drank mead and CONSAGRAVED those who had discovered the spirit of the MINNESÄNGER.

The presence of a Mystery of Love in his blood.

It is worth adding, as a complement, the curious relationship between the runic sign of Anise and another of the sacred beverages, this time from Turkey, the "anise". The word "anise" is very ancient, from Atlantean times, and therefore much earlier than the Germanic futhark, although they also descend from an Atlantean system: the acoustic cabala. It has a root "AN" which alludes to "ancient gigANte" as in "AtLANte" or in "ANteo". The second part, "IS", rather than with the Egyptian goddess ISIS has to do with FRYA the Norse goddess, lady of the ice, which is a late and western version of LILLITH, hyperborean goddess associated with the planet Venus. Precisely the rune "IS", whose symbol is i, means "goddess of ice" and corresponds to the number 22 in the old futhark. The rune number four, of the same alphabet, is called ANsuz and is consecrated to the AS WOTHAN; ITS SYMBOL IS:



The union of the runes "ansuz" and "is" forms the word "anise", the runic spelling of which is the following:



This powerful symbol, together with the eight-pointed star, represents the Power of the Lords of Venus: the Berserkir drew the rune "anise" inside an eight-pointed star as the main symbol of their coats of arms and shields and, as we have already seen, Wildejäger used its power against the demons of Hel.

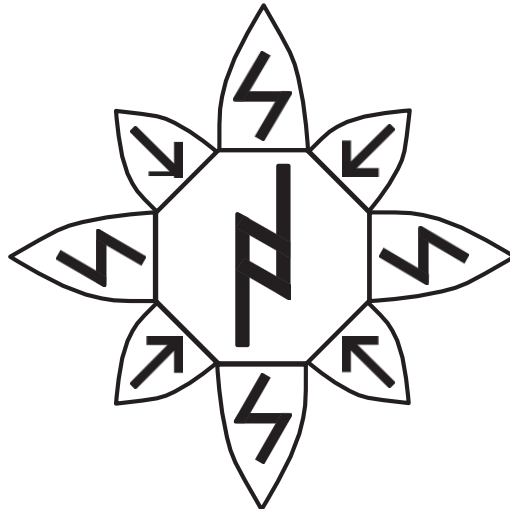



It is known that "anissette", a spirit made from "anise" (PIM-PINELLA ANISUM) has been consumed with particular pleasure since ancient times in the Near and Middle East. The first name of this umbelliferous plant is of Greek origin, ANISON, with roots equivalent to those already given for "anise". What is curious here is not the coincidence of names but the fact that another eau-de-vie, similar to aniseed, was chosen by many very secret Islamic sects as the sacred drink par excellence. This second eau-de-vie, whose resemblance to anissette is so remarkable THAT IT CANNOT BE CASUAL, is made from the fruit of the BADIAN tree. And this is the major coincidence: the capsular fruit of the Badian, whose aroma and flavor are so similar to anise, is presented in small clusters of EIGHT seeds, following such a strict symmetrical law that all of them form an octagonal star. It is for this reason that it is called "star anise", even if it is not "true anise", and it cannot but be striking to see again the symbols of the Lords of Venus associated: the name "anise" and the eight-pointed star, not to mention the sacred drink...

When the berserkir ceased to apply the law of the encirclement on the arquémona and to practice the strategic opposition against the lapis oppositionis, the spatio-temporal gap between the square and the Valplads ceased and soon everything returned to normal in the subway crypt. The DENSE AIR dissipated and the sixteen berserkir were seen standing in different places in the square, each one of them concentrating on the synchronization ritual, but without abandoning their warrior postures: the shield raised and, in the right hand, the axe describing a threatening semicircle. They had fulfilled the initiation ceremony and a new member, Wildejäger, had joined the Einherjar; for another seventeen and a half years no one else would get that privilege. But this time a second ceremony had to be performed, as we have already said, in order to consult the Messiah's Game. As the Game is based on principles of synchrony, in order to achieve significant results it is necessary that no spatio-temporal alteration be exerted in its environment; that is, the law of encirclement must not be applied during its operation. For this reason the berserkir, after verifying that the synchronization had taken place without problems and that no "surprises" awaited them in the Valplads, set out to "prepare" the Game for its use.

In the center of the square a column supported the "maquette" of the manger. Next to its base there was a small ark, which remained empty year after year, except for the fleeting moments when the berserkir operated the Game and then fulfilled its mission of keeping all the pieces of the "camouflage". La Castellana began to carefully remove the delicate statuettes, which were fixed to the board by a thin needle, and to hand them to Wildejäger, who gently placed them in the ark. As he took out the replicas of the Virgin Mother and Joseph, the carpenter, the

Castellana proceeded to press her thumb on the back of each, at the level of the back. Immediately it slid forward, exiting through the thorax of both statuettes, a fraction so skillfully concealed that it would have easily escaped the most rigorous inspection. Each of those fractions possessed an ivory inlay set with such perfection that, as they exited, they left behind them the hollow, the exact matrix, of their form. The pieces of ivory so jealously concealed were two regular polyhedrons of different numbers of sides. These bodies, together with an ivory ring taken from the mouth of a miniature cistern, constituted the three throwing elements of the Messiah's Game.

At the end, only the board remained, since all the figures of the manger had gone to the bottom of the ark. However, the dismantling was still to be completed: with precise movements Castellana peeled off one edge of the leather cover, which served as the "floor" of the crib, and rolled it up until it was completely removed, revealing a second leather surface, delicately engraved and painted.

Now the Messiah Set was ready to be used! The ivory polyhedrons displayed strange symbols, engraved on each of their faces and painted with colored enamels. The surface of the board basically represented a map of Europe and Asia, but overlaid with such a profusion of runes and magical symbols that it was not recognizable as such to the naked eye. On it would fall the polyhedrons and the ring "detecting" strategic situations by means of the "position" they showed, which would be analyzed and interpreted by the berserkir.

La Castellana took her own leather helmet and turned it, leaving the hollow part upwards, in the manner of an enormous basin, into which she threw the polyhedrons and the ring. She then shook the helmet and handed it to the nearest berserkir, who also shook it and passed it in turn, as the ritual indicated, to another berserkir. A few seconds later, after having passed through all the hands, the helmet returned to the Castellana who prepared to perform the roll. Each berserkir adopted at that moment a mudra of war and, when the ivory bodies flew towards the board, from their fifteen throats burst out in unison: B-LD-R, the name of the Siddha who was the charismatic center of the Einherjar (or S.D.A.). La Castellana did not share this ritual and, at the moment of throwing the bodies, simply asked aloud: When is the H.H.H. guideline fulfilled?

They rolled the polyhedra and the ring until they stopped at different places on the board. It can be said that while this was happening, breathing seemed to have stopped in the berserkir, as their sixteen pairs of eyes attentively followed the mo-

The movement of the bodies. But when they stopped and left a "position" determined, several exclamations -some swearing and cursing- showed that the "answer" was not to the liking of those present.

To understand such a reaction, it must be borne in mind that the Messiah's Game was in reality a "synchronistic detector of state", that is, a tactical instrument, an element of war. Its function was to "measure" the scope of the strategies in play, making use of phenomena of "first degree" of determination, that is, without any other "intentionality" intervening, subject only to the free play of natural laws, to their mechanical determination. The question and the movement of the bodies occur SIMULTANEOUSLY and therefore it is to be expected that a relation exists between both facts. But such a relation will never be "cause and effect", where one phenomenon determines the other, that is to say: the question DOES NOT DETERMINE the position of the polyhedra, but is synchronistic with it; and that is why the "position" is significant. It is necessary to meditate a lot on the metaphysical implications of this way of acting in order to understand that, by asking and throwing SIMULTANEOUSLY the bodies, NATURE CANNOT AVOID GIVING THE ANSWER. For the

On the contrary, this semiotic response HAS BEEN RAPPED TO DEMIURGE BY A TACTICAL STRIKE FROM THOSE WHO KNOW WHAT THEY ARE DOING. Only the Siddhas or the

Awakened viryas, who master the highest gnosis, can face a similar warlike operation, in which one's strategy is put to the test in open defiance of the enemy's strategy.

What did the berserkir expect to find in the "position" of the bodies? We said it at the beginning: a precise indication of the H.H.H. pattern. The Messiah's game was able to "detect" the Time when the Envoy of Wotan would come and to express it by means of its "winning position". When the Time of the Envoy was near, the semiotic polyhedra would fall synchronistically revealing the transcendent fact; then the Einherjar or S.D.A. would fulfill its mission to "find" the Envoy and deliver to him the secrets of the Hyperborean Wisdom; then the Order would be dissolved and the last berserkir would be free to leave or accompany the Great Chief in his Total War against the "elementalwessen".

Apart from the "winning position", any other distribution of the bodies on the board infallibly showed the relationship of forces existing at the moment of the roll. In other words, an analogical evaluation of the "position" made it possible to know one's own situation and the intensity of the enemy pressure, making possible with these data an OBJECTIVE, periodic verification of the correct marketing of one's own strategy.

With these concepts, considering that the greatest aspiration of the berserkir was to share the glory of ACCOMPANYING THE SENDER in his mission of guiding and transmuting the Hyperborean peoples, it will perhaps be understood why they were so displeased to find that the bodies had NOT FALLEN IN THE WINNING POSITION and should therefore wait another thirty-five years until History offered a new GENERATIONAL opportunity. Because the fact that during the operation of the Game the "winning position" did not come out meant fundamentally that THE RACE WAS NOT YET PREPARED TO RECEIVE THE SENDER OF THE GODS. And then, after the curses and fierce oaths that the berserkir vociferated when they realized that the Time of the Envoy was still far away, they sighed and lamented in sorrow for the confused situation of the lost viryas.

But, even if the winning position was not given, an analysis of the situation of the polyhedrons on the board would give important strategic information. For example, the new "position" indicated to the Berserkir that, as had been the case for many decades, the maximum enemy pressure was registered in a specific place in southern Germany. This and much more, the synchronistic state detector let them know. But we will not transcribe here the conclusions drawn from the analyses and evaluations of each "position"; it would be too long and difficult to interpret without prior knowledge of the concrete form of the Messiah's Game. Our intention was simply to transmit an idea about the instrument designed by John Dee as part of element (3) of his A1 Strategy, that is, of the Method that makes possible the attainment of the H.H.H. Guideline. We believe that, with what has been said so far about the Messiah Game, this enlightening purpose has been fulfilled.

Therefore, we will leave for the moment the berserkir of the S.D.A. We will leave the subterranean crypt and its terrible Mystery and we will occupy ourselves with unraveling the last question that remains in the present Course of Action. It was left pending from the beginning and refers to the question: What procedures are indicated by the Method to recognize the Envoy?

It will be convenient to go back to the beginning and return to the text of paragraph II-d which reads (ANALYSIS OF ELEMENT 3): "The method must fulfill, among others, the following main conditions: 1st it must give, at any time, an objective indication of one's own situation and the enemy's position; 2nd it will determine with absolute certainty the moment when the pattern H. H. H. H. 'is about to be fulfilled'; 3rd it will enable the S.D.A. to recognize unmistakably the Envoy of Wotan, that invincible Germanic chief upon whom the pattern depends.H.H. 'is about to be fulfilled'; 3. it will enable the S.D.A. to recognize unmistakably the Envoy of Wotan, that invincible Germanic chief upon whom the H.H.H. pattern depends."

As has been said, the Messiah Game allowed the 1st and 2nd conditions to be fulfilled with absolute precision. As for the 3rd point, neither John Dee nor Wilhelm von Ro-semberg came up with a way of identifying the Messenger that could be reliably applied in any epoch. While the "winning position" would reveal with certainty that "the Time of the Sent One has come," no one could anticipate when that event would occur, which was perhaps several centuries in the future. This uncertainty made it impossible to describe the historical profile of the Great Leader and thus made it difficult to trace the patterns for his identification.

In 1589, shortly before leaving for England, John Dee consulted the Siddhas about the third condition, using the stone mirror of Princess Papan. The answer obtained, due to its enigmatic and prophetic character, caused a great surprise to John Dee, Wilhelm von Rosemberg and the eight princes of the Dynasty. First of all, the Siddhas asserted that the problem of the 3rd condition was wrongly posed because it was not up to the berserkir to identify the Envoy, but for him to prove that he was one. They then went on to say that a racial Strategy could fail if the meaning of the 3rd condition was not correctly understood and that recently, in the time of Frederick II Hohenstauffen, in fact, a Grand Strategy had failed because of misunderstandings over the same issue. These surprising arguments led John Dee to repeat the question and request from the Siddhas a concrete answer as to how the Envoy should then prove his identity. Predictably, this insistence was not to the liking of the Siddhas who responded laconically that: "in the 13th century the Siddhas sent to Genghis Khan the instructions for identifying the Universal Emperor. These instructions are still in force and the Envoy H.H.H. will undoubtedly be the one who can correctly read the Scroll of Genghis Khan". And the Siddhas refused to give any further information. It is difficult for anyone to imagine the state of alertness, **t h e** determination to unravel the enigma, the firm resolution to know the truth whatever it might be, in short, the will to overcome the obstacle that the ten initiates exhibited before the Mystery represented by that Scroll of Genghis Khan of which no one had ever heard. In those days of 1589 a feverish psychic activity enveloped the founders who tried, at any cost, to find an answer and for this purpose they resorted to all the esoteric resources available. The A1 Strategy was ready for its execution, which began with the foundation of the Dynasty and the search for the "declared objectives", leaving only the 3rd condition of the Method to be solved. But, as all the efforts made to elucidate the Mystery were then unsuccessful, the plans were equally set in motion, although without abandoning at any time the investigation of the enigma.

John Dee and Wilhelm von Rosemberg hoped to find an early solution; but things did not turn out as they wished, for it was not until the middle of the 17th century, during the second generation of members of the Dynasty, that enough information was gathered to undertake a rational search for the mysterious Scroll. This search bore fruit at the end of the 19th century, that is, more than two centuries later, consuming in that time enormous energies of the S.D.A., which felt more and more pressed by History. However, in spite of all the difficulties it brought with it, the Mystery of the Scroll of Genghis Khan turned out to be highly beneficial for the S.D.A. and it is to be supposed that precisely because of the great magnitude of its importance, it surpassed the capacity of evaluation of the founders who saw in it only a difficulty. In reality, the Mystery of the Scroll, whose secret plot was gradually becoming known, had the virtue of CONNECTING the S.D.A. with a hyperborean current of History abruptly interrupted in the 13th century. The

S.D.A. took up, in a certain way, that current, which we denote as Strategy "O" of the Siddhas, and updated it in Strategy A1.

In the next chapter, entitled "Historical Outline of the S.D.A.", we propose to show the secret course followed by the S.D.A. between the 17th and 20th centuries, making it clear that its influence on the History of Europe in that period has been more important than might be supposed. But, for the reasons recently stated, the Historical Outline will not begin directly in the 17th century, but will include an introduction in which the "O" Strategy and the events of the 13th century that gave rise to the Mystery of the Scroll of Genghis Khan will be summarized. The development of this chapter will take us directly to the 20th century, to the last two stages of our story: the Germanenorden and the

Thulegesellschaft.

*Genghis Khan was a Mongol warrior and conqueror who unified the Mongolian nomadic tribes of northern Asia, founding the first Mongol empire.*

*Only a part of the author's fourth book (Manual of Psychosocial Strategy) is available on the Internet, so it would be a complementary text that is recommended to be read at the end of the reading of The Secret History of the Thulegesellschaft.*

## HISTORICAL OUTLINE OF THE S.D.A.

### I - STRATEGY "O" OF THE HYPERBOREAN SIDDHAS

In the previous chapter we mentioned "a Strategy that the Siddhas use to counteract "the Culture", enemy strategic weapon, and we explained it by means of an allegory, as consisting of a charismatic message. This message pursued two objectives: 1) TO AWAKEN; 2) TO ORIENT towards the "holy exit", "center" or Vrili; and, in that particular example, the "exit" was found after discovering "the ring", that is, after having made conscious the PRINCIPLE OF THE CLOSET.

However, the second part of the message, the LOVE SONG, offered the listener the possibility of "finding the way out" by six other ways than the STRATEGIC OPPOSITION (which is based on the principle of encirclement). In any case, this Strategy, as we have described it, with its seven possible ways of liberation, responds to purely individual objectives, that is to say, it is directed exclusively towards man (the lost virya). That is why it now falls to us to state that it forms part - the "individual" part - of a larger conception, which we call: Strategy "O".

The "O" Strategy is fundamentally directed to obtain the individual liberation of man; but, on certain favorable historical occasions, the Siddhas seek to "orient" the race as a whole in order to force the collective mutation<sup>1</sup>. In that case the "leaders", many times "sent" by the Siddhas and other times "enlightened" by them, are in charge of projecting charismatically in the people the strategic guidelines, seeking to REINTEGRATE THEM TO THE COSMIC WAR. For such a task to be carried out with probability of success it is necessary that the "leaders" have at their disposal an external element, situated in the world, which represents in an irreplaceable way the divine origin of the race. This external element must also give proof of the commitment made by the Siddhas in "inducing" the viryas to resume the war against the Demiurge and of their resolution to "wait" for the necessary Kalpas while they gain freedom. From these conditions it can be understood that this "external element" is a true STONE OF SCANDAL for the Demiurge and his demonic hosts and that all His Power, that is to say the Great Deception, is placed in achieving its destruction or, failing that, to prevent it from remaining within reach of the Siddhas, and to prevent it from remaining within the reach of the Siddhas.

---

1 *Book 4 discusses at length the meaning to be given to the term "co-lective" in the Hyperborean Wisdom, which differs from its usual meaning.*



of man. But, in spite of the displeasure that such action caused the enemy, the Siddhas have fulfilled their part of the Primordial Pact and, with an admirable disregard for the Power of the Infernal Powers, deposited it in the world and guarded it from any attack so that men or their charismatic leaders would DISCOVER IT AND USE ITS MEANING.

The "O" Strategy of the Siddhas is thus directed inwardly to each man by the "charismatic songs," seeking to awaken in him the memory of blood and to induce him to follow one of the seven ways of liberation. But it also seeks to impel the race as a whole to cease marching in the "evolutionary" or "progressive" direction of History and, rebelling against the Plan of the One, in a reverse leap, to transmute the "animal tendencies of the pasu" and to recover its divine (hyperborean) nature. To achieve this second purpose, no longer individual but racial, we have said that an "external element" is available. What concretely will this "external element" be, this "thing" to which we have attributed such marvelous properties: it is something whose description alone would take several volumes and which, for the sake of brevity, we will call GRAL. Since it is impossible to reveal here a Mystery that has been impenetrable to millions of people, we will try, as usual, to "approach" it by means of a few comments.

We were asking what CONCRETELY will be that wonderful thing that we now know is called GRAL. Let's start there. Concretely, the Gral is a stone, a crystal, a gem; of this there is no doubt. But it is NOT AN EARTH STONE; there is no doubt about that either. If it is not a terrestrial stone, we may ask what is its origin: the Hyperborean Wisdom affirms THAT IT PROVIDES FROM VENUS, but does not assure that this is its origin. We can suppose, for lack of other precision, that the Lords of Venus brought it to Earth, from that green planet. But the "Lords of Venus" do not originate from Venus, but from Hyperborea, an "original center" that does not belong to the material Universe and whose "blood memory" has led many lost viryas to identify it erroneously with a "disappeared" "Nordic" or "polar" continent. According to the Hyperborean Wisdom the Gral was brought into the Solar System by the Siddhas IMMEDIATELY AFTER THEY WENT THROUGH THE GATE OF VENUS TO INSTALL THEMSELVES IN VALHALA. Be that as it may, there are

ANOTHER CONCRETE ASPECT to keep in mind: the Gral is a gem of the greatest importance to the Siddhas, to such an extent that THEY ARE NOT DISPOSED TO LEAVE IT OR LOSE IT. Out of comradeship and solidarity towards the lost viryas, they have SITUATED it in the world; but at the end of Time, the Gral will be recovered and returned to its place of origin.

What is the reason for this unmeasured interest in preserving the mysterious gem? Because it has been momentarily removed from the most beautiful jewel ever seen in the Universe of the One, from that jewel which no one would be able to imitate in this or in other worlds: neither the Master Goldsmiths nor the Devas Builders nor the Planetary, Solar or Galactic Angels, etc. For the Gral is a gem of the Crown of Christ-Lucifer, the One who is purer than the purest of the Siddhas, the only one who can speak face to face with the Unknowable. Christ-Lucifer is the one who, BEING IN HELL, IS BEYOND HELL. Being able to stay in Hyperborean, in the light of the Unknowable, Christ-Lucifer has wanted to come to the rescue of the captive spirits by starring in the incomprehensible sacrifice of His own SELF-CAUTIVITY. He has installed Himself as the Black Sun of the Spirit, "illuminating" charismatically, from "behind" Venus, through the Paraclete, directly in the blood of the lost viryas.

How has a gem of the Gallant Lord been sullied by falling here, to Earth, one of the foulest sewers of the Seven Hells? Because He has so ordered it. Christ-Lucifer has given the Gral to the Siddhas AS GUARANTEE of his commitment to man, of his sacrifice, and AS IRREFUTABLE MATERIAL PROOF OF THE DIVINE ORIGIN OF THE SPIRIT. The Gral is, in this sense, a REFLECTION of the divine origin, which will guide like a lighthouse the wavering course of the rebellious spirits that decide to abandon the slavery of Jehovah-Satan.

We have already seen what the Gral is: a gem of the crown of Christ-Lucifer. Let us now see what the Gral REPRESENTS for the captive spirits. First of all, the Gral is linked to the INCARNATION OF THE SPIRITS, and its meaning must first be sought in relation to that Mystery. This is explained if we take into account that millions of years ago, when the Traitor Siddhas allied with the Demiurge Jehovah-Sa-Tanas to flesh the Hyperborean spirits, Christ-Lucifer gave his gem so that the TRUTH OF THE DIVINE ORIGIN COULD BE SEEN WITH MORTAL EYES. That is why the General, placed in the world as proof of the divine origin of the spirit, DA SENSE TO ALL THE HYPERBOREAN LINEAGES OF THE EARTH. Through him the blood of the viryas, even in the most tremendous confusion, will always claim their HEREN-EXTRATERRESTRIAL SCIENCE.

The presence of the Gral, in principle, PREVENT THE ENEMY FROM DENYING THE HYPERBorean ANCESTRES. But, just as the Gral gives a cosmic sense to the History of man, connecting him with the immortal race of the origins, DIVINIZES the hyperborean lineages of the Earth, so also for the Demiurge, because of the presence of the Gral, these lineages become a "reason for scandal" and object of persecution and scorn, of punishment and pain. The DIVINE hyperborean lineages

will be, from the Gral on, LI-

HERETIC NAJES "condemned" for all "eternity" (a manvantara) by Je-hovah-Satan. The General has come to awaken undesirable memories, to valorize man's past; it will be then the memory and the past that will be most attacked and to ERASE its influence the Synarchic Strategy will aim to a great extent. Let us be capable of noticing this attack, which is evident to the Gnostic gaze, and we will understand in greater depth the HISTORICAL function of the General. We will dedicate the following paragraphs to highlighting it.

Man's chief crime has been to deny the supremacy of "God," that is, of the earthly Demiurge Jehovah Satan, and to rebel against his enslavement. But man is a miserable being, immersed in a hell of illusion in which he foolishly feels "at ease", with no possibility of breaking the spell by himself. If he has denied the Demiurge and "rebelled" it has been by virtue of an external agent, but: what "thing" in the world can be capable of AWAKENING man, of OPENING HIS EYES to the forgotten divinity? "If such a thing exists, the Demons will say, it is the most abominable object of material creation". But that "thing," that "abominable object," is not of this world; and of it the captive spirit-man has "eaten." That "green fruit", which will later be called Gral, is a food that nourishes with the PRIMORDIAL GNOSIS, that is to say, with the knowledge about the truth of the origins. Through the Gral, forbidden fruit par excellence, man will know that he is immortal, that he possesses a divine spirit chained to matter, that he comes from a world impossible to imagine FROM THE EARTHLY HELL, but for which he FEELS NOSTALGIA and to which he WANTS TO RETURN.

**BY GRAL MAN HAS REMEMBERED!**

This is their first crime. To remember the divine origin will be, from now on, a TERRIBLE SIN; and those who have committed it will have to pay for it. That is the Will of the Demiurge, the "Law of Jehovah-Satan". It will be his Ministers, the Demons of Chang Shambala, who will be in charge of executing the condemnation by collecting the punishment in a currency called pain and suffering. The instrument will be, naturally, incarnation, repeated a thousand times in transmigrations "controlled" by the "Law" of Karma, cynically declaring that pain and suffering are "for the good" of the spirits, "to favor evolution". If "evil" lies in the blood, then it will be weakened by favoring racial mixture and made impure by aging it with the FEAR OF SIN. The result will be STRATEGIC CONFUSION of the spirit and complete darkness about man's past. "In the past there is nothing worth rescuing," the sensate people will assert for millennia, in chorus with the Demons of the Hierarchy. Theology, and even mythology, will speak of man's sin in the language of the Demiurge: the "sin," the "fall," the "fall," the "fall," the "fall," the "fall," the "fall," the "fall," and the "fall."

and "punishment". Science", on the other hand, will show us a more discouraging panorama: it will "prove", using fossil filth, that man descends from a protosimian called "hominid", that is to say, from that miserable and despicable animal that was the ancestor of the PASU. Science" has taken man's past to its most dramatic degradation, linking it "evolutionarily" with reptiles and worms. For modern man there will no longer be divine ancestors but apes and trilobites. It really takes a superhuman hatred to want man to humiliate himself in such a sad way.

But let's leave the sad, let's be optimistic. Why look at the past, the Church will say with the voice of science and theology, if man is "something projected into the future"? In the past there is nothing worthy of respect: primitive marine crustaceans sunk in the mud trying to gain the terrestrial environment, driven by "evolution"; millions of years later some apes decide to become men: driven again by the miraculous "law of evolution" they become bipeds, make tools, communicate by talking, lose their hair and enter History; and then comes the History of man: documents, civilization, culture. And in History, "evolution" continues relentlessly, now converted into a more inflexible law called dialectics: the mistakes of humanity (wars, intolerance, fascism) are "errors"; the successes (peace, democracy, the UN, the Sabin vaccine) are "successes". From the dialectic struggle between successes and mistakes always emerges a higher stage, a benefit for FUTURE humanity, confirming the evolutionary or progressive trend. Is not this progressive trend of History ALL THE GOOD THAT CAN BE EXPECTED FROM THE PAST?

So let us be optimistic; let us look to the future; there are all the goods, all the achievements; the theologian assures us that after a FUTURE Judgment the gates of paradise will be opened to the good; the Rosicrucians, Freemasons and other theosophists, place in the future the moment when, having partially concluded the "spiritual evolution", man identifies himself with his monad, that is, with his "divine archetype", and joins the Cosmic Hierarchies dependent on the Demiurge; and even the materialists, atheists or scientisticians, present us with a fortunate image of the future: they show us a perfect society, without hunger or disease, where a man, technocratic and dehumanized, reigns happily over legions of androids and robots.

We will not go into detail about an obvious fact: an attempt has been made to ERASE man's past by disconnecting him from his hyperborean roots; it has NOT BEEN SUCCESSFULLY ERASED; but, on the other hand, a metaphysical fracture has been created between man and his divine ancestors, so that, at present, an abyss separates him from the memories of his ancestors and, at the same time, he is still separated from the memories of his ancestors.

The abyss has a name: confusion. Parallel to this sinister purpose, man has been "projected into the future", a euphemism used to describe the ILLUSION OF PROGRESS suffered by the members of modern civilizations. Such "illusion" is culturally generated by powerful "force ideas" (the "sense of history"; "historical acceleration"; "scientific progress"; "education"; civilization vs. barbarism; etc.), skillfully employed as a strategic weapon. Thus conditioned, people blindly believe in the future, look only to it, and even fatalists, who foresee a "black future", admit that if an unforeseeable exception or a miracle offers a "way out" for civilization, it is in any case to be found in the "future"; the past is in any case a reason for general indifference.

This "obvious fact" undoubtedly represents an important triumph for the Synarchy; but a triumph that is not definitive. Indeed; we have seen that the maximum pressure of the Synarchic Strategy is applied in ERASING the past, in obscuring the memory of the divine origin, and that such an attack is produced as a REACTION to the Gnostic ACTION of the Gral. But the Gral IS NOT ONLY a forbidden fruit, consumed by man in the remote times, immediate to his enslavement.

The Gral is a reality THAT WILL REMAIN in the world as long as the last hyperborean spirit remains captive. Through the Gral it is always possible for man to AWAKE AND REMEMBER.

However, to enjoy its gnosis, it is essential to understand that the Gral, as a REFLECTION OF ORIGIN, shines in the blood FROM THE PAST. His light comes AFTER THE SENSE OF TIME and that is why no one who has succumbed to the Synarchic Strategy will be able to receive his influence. We have already proven that a powerful cultural Strategy "projects man into the future" and tries to erase his past and to merge his memories. But the Gral MUST NOT LOOK FOR HIMSELF LOOKING TOWARDS THE FUTURE, for then he will never be found. Strictly speaking, the Gral MUST NOT SEARCH IN ABSO- LUTO, if by the verb "SEARCH" we mean an action that implies "movement". Only those who have not understood its metaphysical meaning and believe, in their ignorance, that it is an "object" that can be "found" are "looking for" the Gral. Let us recall one of the medieval stories about the Gral, which, although deformed by its Judeo-Christian adaptation, retains many elements of the Hyperborean Tradition. In it Parsifal, the pure madman, goes out to "search" for the Gral. In his ignorance he commits the folly of undertaking the search by "traveling" chivalrously through different countries. This "displacement" points ESSENTIALLY TOWARD THE FUTURE, because in every movement there is an immanent and inevitable temporality and, naturally, Parsifal never "finds" the Gral "looking for him" in the world. Thus they pass

years of fruitless searching until he understands this simple truth. Then one day, completely naked, he appears before an enchanted castle and, once inside, THE THRONE APPEARS TO HIM (he cannot find it) and his eyes are opened. He then notices that the THRONE IS VACANT and decides to claim it, finally becoming King.

We must see in this allegory the following: Parsifal understands that the Gral MUST NOT BE SEARCHED in the world (Valplads), through time (flowing Consciousness of the Demiurge), and decides to avail himself of a STRATEGIC HYPERBorean WAY. For this he SITS "naked" (without the preeminent cultural premises) in a castle ("square" fortified by the law of the fence), desynchronizing himself from the "time of the world" and creating a "time of his own", inverse, that "points to the past". Then the General appears and "opens his eyes" (memory of blood; Minne). Parsifal notices that "the throne is vacant" (that the spirit or Vril can be recovered) and decides to claim it (he undergoes the purity tests of the secret ways of liberation) and becomes King (he transmutes into immortal Siddha).

We hope we have made it clear that the Gral is not to be sought, for he appears only when the consciousness of the virya has become desynchronized from the time of the world and has shed the cultural mask. We now wish to show another aspect of the enemy reaction which has prompted the presence of the Gral.

By the Gral man commits the crime of awakening; he has "sinned" and the punishment is charged in the currency of pain and suffering, by incarnation and the law of Karma. Those in charge of watching over the Law, and who are most offended by the hyperborean memory of awakened men, are the "guardian angels", that is to say, the Demons of Chang Shambala and his White Hierarchy. There is, apart from this, a DIRECT REACTION OF THE DEMIURG which is worth knowing. But, as such a reaction has been repeated many times since the Hyperborean spirits have been chained to the yoke of flesh, a full exposition would have to cover an enormous span of time, which goes beyond the official History and is lost in the night of Atlantis and Lemuria. Of course, we cannot embark upon such an account; and therefore we refer only to the reaction of the Demiurge IN HISTORICAL TIMES; but it must not be forgotten that whatever is said about this fact IS NOT EXCLUSIVE OF AN Epoch, but has already been and will surely be again.

When the naive question is posed as to what are the worlds from which the captive spirit proceeds, believing that there may be some image that represents the unimaginable Hyperborea, the Hyperborean Wisdom usually answers with a metaphorical figure; it says to the ignorant apprentice: "Imagine that a speck of

pollen is the world from which the captive spirit proceeds".



Suppose that this speck of dust receives a faint reflection of the True Worlds, and suppose that it is then divided and rearranged into infinite particles. Make another effort of imagination and suppose now that the material Universe you know and inhabit has been built with the pieces of that speck of dust. The Hyperborean Wisdom tells you: if you are able to reintegrate in an act of imagination the immense multiplicity of the cosmos into the original mote, then, seeing it in its totality, you will perceive a faint reflection of the True Worlds. If you are able to reintegrate the Cosmos into a speck of dust, you will see only a distorted image of the Homeland of Spirit. That is all that can be known FROM HERE".

The metaphor becomes transparent if one considers that the Demiurge has constructed the Universe by imitating a clumsy and deformed image of the True Worlds. He has breathed His Breath into matter and arranged it for the purpose of "copying" the faint reflection it once received from the Uncreated Spheres. But neither the substance was adequate nor the Architect qualified for it, and, added to these evils, must be considered the perverse intention of pretending to REIGN AS GOD OF THE WORK, in the likeness (?) of the Unknowable. The result is plain to see: an evil and insane hell, in which, long after its creation, by a Mystery of Love, countless immortal spirits were enslaved, chained to matter and subject to the evolution of life.

The main characteristic of the Demiurge is evidently IMITATION, by means of which he has tried to reproduce the True Worlds and whose result has been this vile and mediocre material Universe. But it is in the different parts of His Work where the hallucinating persistence in imitating, repeating and copying is noticed. In the Universe "the whole" is always a copy of "something": the "atoms", all similar; the "cells" that divide into analogous pairs; the "social animals", whose gregarious instinct is based on "imitation"; the "symmetry", present in an infinity of physical and biological phenomena; etc. Without going into further examples, it can be affirmed that the overwhelming formal multiplicity of the real is only an illusion resulting from the crossing, intersection, combination, etc., of a few initial forms. In truth the Universe has been made from a few different elements, no more than twenty-two, which support, by their infinite combinations, the totality of existing forms.

Bearing in mind the imitative principle that governs the work of the Demiurge, we can now consider HIS DIRECT REACTION to the presence of Gen.

We said that Gral DIVINIZES the hyperborean lineages by PROVING in an irreprovable way the truth of the origin; and that the reaction of the Demons has been to consider

the same as HERETIC LYNCHES, deserving of the most terrible punishment.

But while the Demons were busy punishing the viryas with the heavy chains of Karma, very different would be the attitude of the Demiurge. He, according to his characteristics, has wanted to IMITATE, and even surpass, the Hyperborean lineages by founding a SACRED RACE that represents him DIRECTLY, that is to say, that CHANNELS HIS VOLUNTAD; and through it, to reign over the incarnated spirits. A "sacred race" that rises up in the very midst of the peoples condemned to the pain and suffering of life and that, triumphing over them, ends by inflicting on them the final humiliation of submitting them to the Sinarchy of the Demons. Then the heroic lineages, sunk in the mud of spiritual degradation, will exhale their last laments and those cries of pain, those screams of fright, will be the sweet music with which the sacred race will give to their "God" Jehovah-Satan, the Demiurge of the Earth.

As we have already said, the Demiurge has attempted this enterprise many times; "the Gypsies", for example, are the ethnic remnant of a "sacred race" that flourished in the last Atlantis, when the Siddhas of the Tenebrous Face subjected the Hyperborean lineages to the Sinarchy of Horror. The incarnated spirits were there precipitated to the most infamous practices: the divine blood was degraded and confused by means of the indiscriminate mixture of races and, what is worse, fertile unions between men and animals were achieved with the help of black magic; thousands of human victims were immolated to satiate the thirst for blood of Jehovah-Satanas, worshipped there in his aspect of "God of the infernal armies". Cruelty, collective orgy, various forms of drug addiction, etc., were all "customs" that the Hyperborean lineages had adopted; while in the eyes of the "sacred race" the gaze of the Demiurge shone with joy, the Sinarchy of Horror exercised its tyranny of orichalcum. In such a state of degradation, no one was any longer able to receive the light of the Gral or to hear the song of the Siddhas. That is why Christ-Lucifer decided to manifest himself IN THE SIGHT OF MEN. He did it, accompanied by a guard of Hyperborean Siddhas, and this determined the end of Atlantis...

But this is an ancient story. In recent times the Demiurge has resolved to REPEAT again, in imitation of the Hyperborean lineages, the creation of a "sacred race" to represent him and to which will be reserved the high destiny of reigning over all the peoples of the Earth. With the blood pact celebrated between Jehovah-Satan and Abraham, the "sacred race" is founded and its descendants, the Hebrews, will constitute the "chosen people". Just as the hyperborean spirits divinized by the presence of the Gral represent the "heretical lineage" par excellence, the Hebrews, in front of them, will be presented as the "purest lineage of the Earth".

Israel, the people chosen by Jehovah-Satan to be His representative on Earth, what titles will they exhibit as IRREFUTABLE PROOF that such is His Will? The Demiurge, following his usual system of "imitation", reasons in this way: *"If by the gem of Christ-Lucifer, the General, the hyperborean lineage has been divinized, the lineage of Abraham will also be consecrated by a "stone from heaven". I will place in the world a stone on which My Law will be written as IRREFUTABLE PROOF that Israel is the chosen people, before whom the other nations will have to humble themselves.*

Such is the direct reaction of the Demiurge. He chooses from among the mass of humanity the most miserable people; and after making a pact with them, he makes them "grow" in the shadow of powerful kingdoms. When he decides that the time has come for the "sacred race" to fulfill its historical mission, he "renews the covenant" by giving Moses the key to Power. Then Israel, the purest lineage of the Earth, crosses the millennia and marches towards its future of glory, while empires and kingdoms sink into the dust of History. Undoubtedly, the reaction of the Demiurge has been effective and the effects of His Stone, the force of His Law, have been powerful. That is why it is worth asking

What is it in reality that Jehovah-Satan gives to the Hebrews as an instrument of power and universal domination? We will say it synthetically: the "tablets of the Law" contain the secret of the twenty-two voices that the Demiurge pronounced when he ordered matter and by which all that exists has been formed. The set of symbols contained in the Tablets of the Law is what is known from ancient times as ACOUSTIC KABALA. In Atlantis this knowledge was at first the patrimony of another "sacred race"; but later, the Guardians of the Lithic Art, ancestors of the Cro-Magnon and fathers of the white race, came to master it completely.

"The tables of the Law" are then "the stone" that the Demiurge has placed in the world as the metaphysical support of the "sacred race", in imitation of the whole "Hyperborean/Gral lineage". However, as in all the "imitations" of the Demiurge, one should not see here a too precise equivalence. The Gral, from the past, reflects for each of the viryas the divine origin and constitutes an attempt of Christ-Lucifer to come to the aid of the captive spirits or, in other words, the influence of the Gral points to the individual and the spiritual. The Tablets of the Law, on the contrary, point to the collective and material; they represent the racial, collective pact between Jehovah-Satan and the Hebrew people and, in addition, their cabalistic content reveals the keys that allow the mastery of all the material sciences.

If strategic confusion, incarnation, enchainment to the Law of Kar-ma, etc., are terrible evils that afflict the Hyperborean spirits, terrestrial coexistence with a "sacred race" of Jehovah-Satan is undoubtedly the most frightful nightmare,

worse even than any of the aforementioned misfortunes. Because, as of

of the "renewed covenant" with Moses, the RACIAL enmity between the hyperborean ("heretical") lineages and the sacred ("Hebrew") lineage will be permanent and eternal, with the irreversible disadvantage for the former that the infernal Will of the Demiurge will express itself irresistibly through the latter.

After the "appearance" of Israel, the viryas have only the dramatic alternative of returning to the Origin or succumbing definitively.

Digging into the Hebrew myth of Abel and Cain, under a veil of slander, an accurate description of the racial and theological enmity between Hebrews and Hyperboreans can be seen. In this myth, Abel, who is a herdsman, represents the basic TYPO of the Hebrew; and Cain, the farmer, the figure of the virya. Legend has it that Jehovah-Satan was pleased with the blood offerings of Abel the shepherd, consisting of the sacrifice of the firstborn lambs "with their fat"<sup>1</sup>. On the other hand, he despised the "fruits of the earth" exhibited by Cain, whom he finally condemned to wear a "mark", a "sign", that would betray his condition of "murderer".

This curious affective criterion of Jehovah-Satan has been perpetuated through the centuries in the hatred that the Hebrews feel towards the Hyperborean lineages, a hatred that, let us not forget, COMES FROM THE DEMIURGO.

It is interesting to learn more about the figure of Cain. According to the Bible, he was, in addition to being a farmer, the first to BUILD WALLED CITIES and the inventor of weights and measures. His descendant, Tubal-Cain (mythical split of Cain himself) was a manufacturer of weapons and musical instruments.

If we now observe this figure of Cain in the light of the Hyperborean Wisdom, we will see that he possesses many of the characteristic attributes of the Hyperborean viryas. First of all, the association of Agriculture with the construction of walled cities is a very ancient Hyperborean strategic formula recently used, for example, by the Etruscans and the Romans, and which has been expressed with perfection by the Germanic king Henry I, the Birdman, idol of Heinrich Himmler.

---

1 *When evaluating "blood offerings", the figure of the "shepherd" should never be confused with that of the "hunter". The shepherd is the one who slaughters his PREVIOUSLY DOMESTICATED victim. The hunter, on the other hand, like the warrior, obtains his prey after fighting with it and defeating it.*

and Walter Darré<sup>1</sup>. On the other hand, the invention of weights and measures, which the Hebrews attribute to Cain, the Greeks to Hermes and the Egyptians to Thoth, makes it possible to identify Cain with these two Hyperborean Gods. And, finally: the accusation of murderer and the condition of weapon maker, clearly reveals that the figure of Cain represents some FEARFUL WARRIORS, perhaps the BERSERKIR; to betray or indicate that quality surely points to the famous mark.

In the Bible, the sacred book of the "chosen people", in the myth of Abel and Cain, the rules of the game are perfectly revealed. In the "preference" of Jehovah-Satan for the Hebrew shepherds, represented by Abel; and in the contempt and punishment of the hyperborean lineages, symbolized by Cain, the metaphysical conflict of the origins appears, but now updated as a cultural and biological confrontation. The sacred Hebrew race has come to bring the Presence of Jehovah-Satan (CONSCIOUS Presence, different from the PANTEISTIC BLOW with which the Demiurge animates matter) to the plane of human life, of incarnation, of pain, of suffering. That is why the ancient transcendent enmity between captive spirits and Demons is transformed into immanent enmity between the Hyperborean lineages and the material Universe, given that the sacred race is MALKHOUTH, the tenth SEPHIRO-TH, that is to say, an aspect of the Demiurge. The latter should be understood as follows: ISRAEL IS THE DEMIURG. It is worth clarifying. According to the secret teachings of the Kabbalah and as can be read in the Book of Splendor or SEPHER YETSIRAH, i.e., according to the most reliable sources of Hebrew Wisdom, for the "creation" of the "sacred race", Jehovah-Satan manifests one of the most important aspects of the "sacred race". Jehovah-Satan manifests one of his ten aspects or SEPHIROTH. The tenth sephiroth, MALKHOUTH (THE KINGDOM), IS THE PEOPLE OF ISRAEL OWN, according to the official Hebrew texts, which has a metaphysical link with the first sephiroth, KETHER (CROWN), which is the supreme Head or Consciousness of the Demiurge<sup>2</sup>. In other words: there is a metaphysical identity between Israel and Jehovah-Satanas or, if you will, "ISRAEL IS JEHOVAH-SATANAS".

As we said before, the enmity between the sacred race and the hyperborean lineages, an enmity that we have seen declared in the myth of Abel and Cain, signifies a confrontation between them and the material Universe, given the character of Malkhouth, a splitting of the Demiurge, which Israel holds. With Malkhouth, the Demiurge has

---

1 *In the Third Dissertation, "H. Himmler's Incredible Secret," we will return to this relationship.*

2 *According to the Kabbalah, Malkhouth, the royalty, becomes SHEKINAH "after the sin of Adam" and will remain so, as the feminine aspect of Jehovah-Sa-*

*Tanas, "until the coming of the Messiah". In order not to complicate the commentary, we will use only the concept of Malkhouth.*

The White Hierarchy has wanted to impose THE KINGDOM of the sacred Hebrew lineage upon the remaining peoples of the Earth. If these Gentile peoples HAVE FORGOTTEN THE PAST and have submitted to the Plan carried forward by the White Hierarchy, then they will willingly accept the HEBREW SUPERIORITY and the world will march joyfully toward Sinarchy. But,

Woe to those GOYM who do not renounce their hyperborean heritage and persist in remembering the conflict of the origins! There will be no place for them on Earth because with the Presence of Malkhouth, the sacred lineage of Israel, the Demiurge assures their persecution and immediate annihilation. Dramatic destiny of the captive spirit! For millennia REMEMBERING THE ORIGIN, that is, exhibiting a heretical lineage, was punished by the Demons with a strong Karma, and the pain, the suffering, was so terrible that it was eventually forgotten. But, while this degradation was happening, in the bottom of his heart, boiling in his blood, the condemned could participate in the Minne and accede to the GNOSIS; it was his right: if he succeeded in rising from the swamp of spiritual confusion, nobody could prevent him from receiving the light of the Gral nor from listening to the song of the Siddhas. With Israel, not even this miserable opportunity of awakening would be possible anymore, since the conflict was posed in biological, racial, cultural terms...: whoever engages in the contest must now risk everything, for in confronting Israel, he is confronting the Demiurge himself.

Israel is advancing in history with irresistible force. Its great ideas are gradually undermining the culture of the West, in parallel with the growth of its financial power. Who will be able to oppose the combined force of Judeo-Christianity, Judeo-Masonry, Judeo-Marxism, Zionism, Tri-lateralism? Who could "blow up" the benches of ROTHSCHILD, JACOBO SCHIFF, KUHN AND LOES, ROCKEFELLER, etc., and who will compete with the Hebrews in the fields of science or art? We have already described in the First Dissertation the fantastic MATERIAL POWER of the Synarchy; against these organized forces, the virya does not stand a chance. That is why, in the face of such formidable power, the only valid strategic alternative is racial confrontation: to the sacred race of Jehovah-Satan to oppose the hyperborean lineage of the captive spirits. And in this clash of lineages, in this war carried to the terrain of blood, the awakened virya, he who remembers and wishes to return, must listen to the chant of the Siddhas and, following a secret path of liberation, find "the way out", conquer the Vrila, and transmute himself into an immortal Hyperborean Divine. He will have thus fulfilled the first part of the "O" Strategy. But if a charismatic leader, awakened and transmuted, puts himself at the head of a racial community and decides to guide the viryas TOGETHER back to the origin, he will be able to apply Strategy "O" in its totality, taking advantage of the presence of the General. In this case the leader will raise the Total War against the demonic forces of the Sopharchy, but especially he will exert his maximum pressure ON THE SACRED RACE, since it represents DIRECTLY



the enemy, that is, the Captivating Demiurge. Without

However, only in modern times, when the universal presence of the Sinarchy and the power of the sacred race will become evident, will it be possible for some Great Chief to correctly identify the enemy and declare Total War against them.

The irreconcilable enmity between the sacred Hebrew lineage and the heretical Hyperborean lineage could be exemplified by considering the infinite number of times that confrontations have taken place and describing the different results. We can assure you that there would be material to fill several volumes, which is why we must be prudent and refer to what is strictly necessary for the understanding of the Strategy "O" of the Siddhas. It is with this in mind that we will consider only one example, but an example that will be highly clarifying.

The Hyperborean lineages, from the most remote antiquity and whatever the historical time or the country considered, have always agreed that human society should be organized around three main functions: regal, priestly and warrior. The HARMONY and INDEPENDENCE of the three functions would guarantee a certain balance appropriate for times of peace and prosperity, that is, WHEN SOCIETY PROGRESSES MATERIALLY TOWARD THE FUTURE. In different At times in their history, very many peoples of hyperborean lineage experienced brief periods when the balance of the three functions allowed them to enjoy that social tranquility, mediocre and courtly, which in reality concealed a total absence of charismatic contact between the mass of the people and their leaders, a typical situation characterized by general indifference.<sup>1</sup> When a society is stabilized in this way, the White Hierarchy of Chang Shambhala affirms that it "evolves" and "progresses". It is therefore in the interest of the Demons to bring humanity to a state of permanent equilibrium of the three functions, for what purpose? To prepare for the advent of Sinarchy,<sup>2</sup> that is, the Concentration of Power in the hands of a Secret Society or occult brotherhood. What is the purpose of concentrating power in the hands of beings acting in the shadows? The answer is related to the manifestation by the Demiurge of MALKHOUTH, the sacred race: THE POWER OVER THE NATIONS BELONGS (at this stage of the Kaly Yuga) TO ISRAEL AS THE INHERITANCE OF JEHOVAH-SATANAS AND PROOF OF HIS THEOLOGICAL LINAGE. WHILE ISRAEL'S TIME IS COMING, THE SYNARCHY WILL BE THE RULER OF THE POWER CONCENTRATED BY THE WHITE JERARCHY.

---

1 *The reversal of this social apathy requires the use of a Hyperborean Mystique, a matter that will be discussed at length in book 4.*

2 *The word Synarchy means, etymologically, Concentration of Power, from SYN = concentration and ARKHIA = power.*

It is understandable that the Siddhas, faced with such a conspiracy, try to destabilize the synarchic equilibrium of societies and charismatically influence the viryas in order to awaken one of them and transmute him into a hyperborean leader. Such is, fundamentally, the objective of Strategy "O". That is why the song of the Siddhas calls unceasingly in the pure blood and the Gral is a permanent presence that shows, to whoever wants to see it, the reflection of the divine origin of the spirit.

But it should not be believed that Strategy "O" is successful only when a real transmutation of virya into immortal Siddha takes place; that is undoubtedly the most important success; but it is not very frequent, especially in the case of leaders or conductors of peoples. There are other cases, however, not as showy or evident as a transmutation, but whose beneficial influence in the organization of societies has motivated them to be considered as successes of Strategy "O". We refer specifically to those leaders who, with a certain degree of unconsciousness, listen to the charismatic chant and intuit some principles of the Hyperborean Wisdom. As they are not fully awake and ignore the origin of the "message", they proceed to apply the strategic principles in the government of their peoples, taking them as their own invention. We could abound in examples, but it will be of particular interest to us to consider the case of those who have "discovered", without knowing it, the principle of encirclement.

When in the mental structure of a leader the "principle of the fence" has been incorporated, his pure blood, and with it the chanting of the Siddhas, impels him to apply the "law of the Fence" in all his concrete acts. Thus arise from particular societies to political, philosophical, moral theories, etc., conceived and executed according to the law of encirclement, within the framework of Strategy "O". A typical example is the idea of the "Universal Empire". It is worth commenting on it.

When Strategy "O" succeeds in awakening the divine nature in some leader, it is feasible that his subsequent activity will provoke notable social changes. If he is a king, that is to say, if he holds the regal function, he will advance ghibellinely over the sacral function and, with the support of the warrior function, he will try to expand the limits of his State. If the leader is a notable warrior, it will not be long before he will take the crown and then, crushing the priestly function, will set about the task of organizing a military state. In most cases the imbalance of the three functions is at the expense of the priestly function, which is usually lunar and synarchic. The important thing is that the leader, king or warrior, when applying the law of encirclement in his vision of society, generally concludes by agreeing on the idea of the Universal Empire as the most appropriate to demonstrate the superiority of his race and to perpetuate the memory of his

**Nimrod from  
Rosario  
lineage.**

**271**

The universal State of Accad; the Empires of Assyria and Babylon; the Great Persian Empire, destroyed by Alexander the Great; the Roman Empire; etc., have been conceived in the same way: by the application of the law of encirclement, within the framework of Strategy "O", which the hyperborean leaders have made in the course of the millennia. We cannot fail to mention that many "modern ideas" register the same procedure in their conception: such are the different variants of "nationalism", fascism, phalangism, national socialism, "federations" and "confederations", etc. These and many other political theories are the product of the application of the law of encirclement by some modern leaders. In the case of "fascism," National Socialism, etc., it is evident that they have a rather close connection with the very ancient idea of Universal Empire, which eloquently explains why such ideologies have been pursued to annihilation by the sacred race and the forces of the Synarchy.

It is precisely because the idea of the "Universal Empire", which is hyperborean and arises from the application of the law of encirclement, is irreducibly opposed to the idea of the "Universal Hierarchy" advocated by the White Hierarchy of Chang Shambala, and carried forward in favor of the sacred race.

We had proposed to give an example of the irreconcilable enmity between the heretical Hyperborean lineage and the sacred Hebrew lineage; and this has been made manifest in the opposition between the Universal Empire and the Synarchy, that is to say, between their respective ideal conceptions of society. Armed with these keys, anyone can review history and draw his own conclusions; it is therefore not necessary to insist on it any further.

We have previously said that the "sacred race" was created by the Demiurge in imitation of the Hyperborean lineages, and we have shown that the "Tablets of the Law" and the terrible knowledge with which they were written were given to the Hebrews in the MIME of the General. We may now add that the "imitation" did not end there; on the contrary, for centuries an infernal historical falsification was prepared which in fact came to signify an insult infinitely more offensive than the imitation of the Hyperborean lineages or of Gral. We are speaking of the usurpation, vulgarization and degradation perpetrated against the divine figure of Christ-Lucifer.

We have already mentioned that, during the days of the greatest spiritual decadence of the Atlantis, Christ-Lucifer MANIFESTED HIMSELF in the sight of the lost viryas. His Presence had the virtue of purifying and orienting many viryas who, thanks to this census to the hells carried out by the Gallant Lord, were thus able to undertake the path of return. However, the cowardly reaction of the Siddhas of the Tenebrous Face was not to be taken into account.

The war, which ended only when the last Atlantis had disappeared, was finally brought to an all-out war, which ended only when the last Atlantis had disappeared. And although the Atlantean continent disappeared, devoured by the waters, and thousands of years of barbarism and strategic confusion erased these events from history, it is no less true that the drama experienced was so intense that it was never completely forgotten in the collective memory of the Hyperborean lineages. Therefore, when the Demiurge conceived the sinister idea of crudely imitating the redemptive image of "Christ-Lucifer descending among men", it was inexorable that such infamy would unleash irreversible changes and definitive confrontations.

What was the Demiurge's intention this time? Incredible as it may seem, he wanted to produce, in IMITATION of the Hyperborean transmutation, A LEAP in humanity. But let us not be too surprised: what was sought was a leap forward, TOWARD THE FUTURE; and above all, it was intended to BIND the members of humanity, without any distinction of race or religion, to a universal PSYCHOLOGICAL TYPE, that is to say, to a COLLECTIVE ARCHETYPE. That archetype, of course, was that of the HEBREW RACE; for what was ultimately intended was to JUDAIZE humanity and prepare it for the World Government of the Synarchy.

In order to carry out such an ambitious plan, numerous forces would be set in motion, which would concur toward the figure of the Messiah and make possible his earthly ministry. For the mission of "preparing the vehicle" by which Jehovah-Satanas would manifest himself to men, one of the Masters of the Wisdom of the White Hierarchy was commissioned, who was to be known, after his incarnation, as Jesus of Nazareth. Nor was the question of lineage neglected; and so the Master Jesus incarnated in the bosom of a Hebrew family whose genealogy could be traced back to Abraham. But the physical body of the Messiah would possess a constitution different from that of a simple Hebrew: Mary would be impregnated "by sight" by one of the Demons of the Hierarchy, the "Angel Gabriel," who actually employs the method of "intersection of fields," one of the three forms of parthenogenesis that exist.<sup>1</sup> The Master Jesus would animate this higher body for thirty years, but it would be the Essene sect that during all that time would be in charge of developing his esoteric potentialities by training him in the secrets of the acoustic Kabbalah. In this task the Essenes would be assisted by the Masters of the Hierarchy, and the latter by the Traitor Siddhas; all Chang Shambhala had concentrated on sustaining the Messiah, since on the success of his mission would depend to a great extent the future "evolution" of humanity. If the work of the Messiah succeeded, the whole of humanity would be "civilized," i.e., Judaized, and "barbarism," i.e., the memory of myths, would be ended.

---

1 *In the Third Dissertation, the three methods of Parthenogenesis are described.*

of the divine ancestors.

The most horrifying part of this conspiracy was that the Demiurge and his Demons were counting this time ON THE BLOOD REMEMBRANCE that the Hyperborean lineages still kept of the Christ of Atlantis to "attract" them towards his imitation, the Jesus Christ, and by means of a fantastic confusion to subdue them definitively. With what colossal hypocrisy the swindle was planned and executed! After Jesus Christ, who would be able to distinguish between the Christ of Atlantis and his caricature? Only a few have sustained the deception, Gnostics, Manichaeans and Cathars; and against them has fallen the anathema of the Dark Forces, persecution and annihilation. The fact is that this Jesus-Christ, as the Judaic archetype that he is, allows many interpretations, all "legal", according to the convenience of the Synarchy: there is a redeeming Christ; a Christ of mercy; a Christ "to come"; a Christ-God; a Christ-man; a social revolutionary Christ; a Cosmic Christ; an Avatar Christ, etc.

What no one will ever be allowed to conceive (or "remember") is a Christ-Light, that is, a Christ-Lucifer. After Jesus-Christ, that will be the greatest sin, the greatest heresy and the deserved punishment will be exemplary punishment.

"In the year 30 of the 'Christian era' the Word became flesh and dwelt among men. He by whose Word the world was created, clothed Himself in the garb of His Hebrew Archetype, Malkhouth, and manifested Himself to men in the person of Jesus of Nazareth. Phenomenon of phenomena, Wonder of wonders, what a prodigious spectacle it must have been to see the Demiurge made man! We must recognize that this time there is an undeniable quality in his infernal idea of imitating the Christ of Atlantis and taking advantage of the blood memory of the viryas. The result is there for all to see. Little by little the peoples came out of "barbarism" and "civilization" reached the farthest corners of the Earth. And men, slowly but inexorably, have been adapting to the Jewish psychological pattern. How was this success achieved? By what collective alchemy did the ephemeral life of Jesus-Christ manage to influence peoples for millennia until it led to their complete Judaization? Was it only the blood memory of the Christ of Atlantis that determined such a result or were there other hidden factors that contributed to the confusion of humanity and its current Judaization? Without going into too much detail, since the subject goes on for a long time, we can say that the Hebrew Archetype of Jesus-Christ, which was, like all archetypes, in an Archetypal Plane or Psychosphere around the Earth, was PRECIPITATED TO THE PHYSICAL PLANE or UPDATED during the incarnation of the Demiurge in the body of Jesus of Nazareth. Such an actualization of the Malkhouth archetype means that a PERMANENT FORCE has been established IN THE EARTH, which acts in a manner equivalent to the gravitational one, "pushing" man into the physical plane.



towards the JEWISH MORPHE. This is due to a reason WHICH IS ALSO A TERRIBLE SECRET: JESUS CHRIST HAS NOT BEEN DISINARNED! On the contrary, has been situated since then "in the center of the Earth", next to the King of the World, radiating from there his "archetypal power" (today we would say "genetic information") in infinite geotopocentric axes that start from the terrestrial center and cross the backbone of men. This is the permanent archetypal force of Jesus Christ. But it is not the only one: an EMOTIONAL Judaic influence also acts on man, radiating from the "chosen people" of Israel itself, since the sacred race is part of the occult anatomy of the Earth, fulfilling the function of HEART CHAKRA or ANAHATA CHAKRA.

With respect to the last question, it is worth noting that the "animal-man" or pasu, created by the Demiurge millions of years ago to "evolve" according to the Plan followed by the seven kingdoms of nature, naturally tended to form a TYPO that responded to some basic archetypes. However, since the year 33 of the Christian era, it can be assured that the Judaic archetype of Jesus-Christ is now the psychological archetype of the pasu, that is, the TYPO towards which it tends by evolution. This means that, in the viryas, who possess by the ancient Mystery of Love an animal inheritance, the tendencies of the pasu will unconsciously drive him toward the Jewish archetype. Only purity of blood can prevent the predominance of the animal tendencies of the pasu and the consequent danger of psychologically corresponding to the Judaic archetype.

We have already shown how the Demiurge took the original conflict to the terrain of racial confrontation, after creating the sacred race in imitation of the hyperborean lineages divinized by Gral. Now we have just seen how a new imitation, this time of Christ-Lucifer, has meant another destructive advance against the hyperborean lineages. The powerful conforming force of the Judaic archetype of Jesus-Christ, acting from the center of the earth in all times and places, has tremendously increased the sleep in which the "blood-consciousness" of the viryas has found itself since ancient times. On the battlefield of blood two esoteric forces are now fighting without quarter: the chanting of the Siddhas and the archetypal Judaic tendency of Jesus Christ. And the "awakening" has become, then, a terrible and desperate struggle waged inside and outside of each one of us, UNCONSCIOUSLY, SOMETIMES.

That is why, after Jesus Christ, it will no longer be possible to qualify either peoples or organizations, but it will be necessary to attend specifically to the degree of confusion of men. It must be so because in many cases, entire synarchic organizations may fall under the command of a man suddenly conscious of some

hyperborean principle (product of the esoteric struggle waged within him), who could even momentarily "twist" the course of the latter.

And vice versa, in other cases it will be able to happen that a group qualified as "hyperborean" is led by more or less Judaized characters. In the extreme we will have Hebrews (blood Jews) who rebel against Jehovah and dramatically try to recover their hyperborean heritage, a case that may occur more frequently than usually imagined, as well as we will often find people who "by the San- gre" claim to be perfect "Aryans" but psychologically prove to be more Jewish than the Talmud. An eloquent example of this is to be found in the Catholic Church, where the worshippers of Jesus Christ and the Demiurge coexist with nationalist and patriotic priests who serve the cause of Christ-Lucifer and the Siddhas without knowing it.

We must therefore be prudent in qualifying human organizations and, even in those that are purely synarchical, we must always stop to evaluate the degree of confu- sion of the men with whom we have to deal. It is considered a sign of strategic capacity the ability to locate the "just man", even within a synarchic organization such as Freemasonry, who will then be spoken of trying to ISOLATE HIM from the organization in which he militates (appealing to the application of the law of encirclement) in order to be able to ADDRESS HIS HYPER-BORAL PART by means of appropriate symbols.

An example of what we have been saying is the case of the so- teriological heresy<sup>1</sup> of Pelagius, also called "Pelagianism". At the beginning of the 5th century, this British bishop began to defend the theory that man, by himself, is sufficient to bring about his salvation. This is possible, according to Pelagius, because "there is in man a principle of spiritual perfection". It is evident to us that in Pelagius the hyperborean lineage predominated. His pure blood soon enabled him to see that man's "salvation" (his "orientation") depended on "a spiritual principle" (or Vril) which should be "discovered" and "cultivated" inwardly. But where the "heretical" position of Pelagius was clearest was with regard to original sin: man has not sinned at all and "if Adam sinned, his sin died with him; it was not transmitted to human offspring". In short, "man is free" and "born without sin"; from there to raising the injustice of pain and suffering, or any other punishment imposed by Jehovah-Satan, there was only one step. Consequently, the persecution against Pelagius began at once and did not end until

---

1 *It is called SOTERIOLOGY because it deals with SOTERIA or the means of salvation and sanctification.*

Its elimination, in Africa, was carried out by the most important ecclesiastical authorities of the time, which proves the fear that its ideas produced, among whom the Popes Innocent I and Zosimo, St. Jerome and the Gnostic apostate St. Augustine stood out.

At the Synod of Carthage in the year 411, seven propositions, a synthesis of his doctrine, were condemned. It is worth remembering them now to prove that they are derived from the Hyperborean Wisdom.

Here are the seven condemned propositions:

1 - Adam, mortal by his creation, would have died with sin or without it.

2 - Adam's sin harmed him alone, not the human race.

3 - Newborn children are in that state in which Adam found himself before his prevarication (i.e., before tasting the forbidden fruit of the Gral.)

4 - It is false that neither by the death nor by the prevarication of Adam must the whole human race die and that it must rise again by the resurrection of Jesus Christ.

5 - Man can easily live without sin.

6 - The right life of any "free man", leads to the heaven of the same the Gospel.

7 - Before the coming of Jesus Christ there were "impeccable" men, that is to say, men who in fact they did not sin.<sup>2</sup>

It is time to ask ourselves: what has become of the Gral and its imitation, the tablets of the Law, after so many centuries of irreducible enmity between Hebrews and Hyperboreans? We shall begin by answering the second part of the question.

The Tablets of the Law contain the secret of the acoustic Kabbalah, that is, the description of the twenty-two voices with which the Demiurge brought about creation. In order to preserve this secret from profane eyes, the Tablets were kept in the "ark of the

---



the covenant", while an "interpretation" of the acoustic Kabbalah was encrypted by Moses in the first four books of the Pentateuch. The twenty-two Hebrew letters, with which the ciphered words were written, are directly related to the twenty-two archetypal sounds pronounced by the Demiurge, which gives them an inestimable value as a magical instrument. But these letters have a numerical meaning, so that every Hebrew word is also a cipher that can be analyzed and interpreted. This is the origin of the Jewish numerical Kabbalah, which should not be confused with the Atlantean numerical Kabbalah, which referred to another system of alphabetical signs. The interpretation of the esoteric content of the Scripture is the object of the numerical Kabbalah; but the knowledge thus obtained must be regarded, from the magical point of view, as far inferior to the mastery of the laws of the Universe which is given by the acoustic Kabbalah.

But the acoustic Kabbalah was "written" on the Tablets of the Law and these were enclosed in the ark, from which they could only be removed once a year for the privilege of the priests. The ark was buried in a deep crypt, under the Temple, by King Solomon, about a thousand years before Jesus Christ, and remained in the same place until the Middle Ages, that is, for twenty-one centuries. We could add THAT IT WAS THE MANNER IN WHICH IT WAS BURIED that prevented the ark from being found earlier; but this comment will not clarify anything if one does not possess the esoteric keys.

At the death of Solomon the kingdom of Israel was divided into two parts. The tribes of Judah and Benjamin, which occupied the south of Palestine, remained under the command of Roboam, son of Solomon; and the rest of the country formed by ten tribes, remained under the command of Jeroboam. In the year 719 B.C. King Sargon of Assyria destroyed the kingdom of Israel and the ten tribes were transported, to serve in slavery, to the interior of Assyria. The two remaining tribes formed the kingdom of Judah from which the present-day Jews are descended, to a greater or lesser extent.

The "ten lost tribes of Israel" did not disappear from history as the self-serving propaganda of the Jews would have us believe, since much more is known about the matter than is said. For example, it is true that there were Hebrews in America and also that a large part of the present population of Afghanistan is descended from the primitive members of the sacred race. But what interests us is to comment that there was a migration of Hebrews to the north, which were led by a powerful Levite caste. After crossing the Caucasus, where they were decimated by hyperborean tribes, they reached the steppes of Russia and there they clashed with the Scythians (they were very inferior in number and practically did not affect their ethnic identity); but the Levite caste did not agree to lose their condition as members of the sacred race by degrading their blood. The Levites remained

Thus, dedicated to the cult and study of the numerical Kabbalah for many years, they made great progress in the field of sorcery and natural magic. When centuries later the Scythians moved westward, a part of them settled in the Carpathians and on the shores of the Black Sea, while another part continued their advance into Central Europe where they became known as CELTS. Accompanying the Celts were the descendants of those Levite priests, now known as DRUIDS, who wielded a terrible power obtained from the mastery of black magic. And, as we have already said elsewhere, the alliance between the Druids and the Celts would never end, extending to the present day.

How did the Levites of the lost tribe come to become Druids? That is to say, how did they obtain their sinister knowledge? The explanation must be sought in the fact that THESE LEVITES, which was not the case with other Jewish priests either then or later, WERE NOT CONFORMED WITH THE KNOWLEDGE THAT COULD BE OBTAINED FROM SCRIPTURE. THEY WISHED TO GO TO THE TRUE SOURCE OF THE

THE ACOUSTIC KABBALAH. Their insistence and perseverance to achieve this purpose, and the fact that they belonged to the "sacred race", moved the Demons of Chang Shambala to entrust them with a very important mission; a mission that required their dynamic interaction in History. The fulfillment of the objectives proposed by the Demons would redound to the benefit of the Levites, since it would allow them to advance more and more in the knowledge of the acoustic Kabbalah. What kind of mission had the Demons entrusted them with? A task that was directly related to their desires: they had to "neutralize" the lithic instruments that thousands of years ago the Cro-Magnon men, Atlantean survivors, had built all over the world. But the Cro-Magnons did not only build megalithic monuments, but their science included other alterations of the environment; and the way in which the Druids were to "neutralize" them ranged from destruction, the engraving of symbols on the large stones, the modification of dimensions or the analogous construction of "other monuments".

Over the centuries, the Druids became great masters in the acoustic Kabbalah and we have already seen in John Dee's story how they were used when they wanted to "recover" some of the Atlantean lithic transducers. We will return to the lost science of the Cro-Magnon and the esoteric mastery of the Druids later on.

While the Druids were marching with the Celts towards Europe, the kingdom of Judah in the Middle East was destroyed by Nebuchadnezzar and its population taken captive to Babylon in 597 B.C. They were freed in 536 and twenty years later, in 516, they rebuilt the Temple of Solomon without finding the ark with the Tablets of the Law. They were liberated in 536 and twenty years later, in 516, they rebuilt the Temple of Solomon without finding the ark with the Tablets of the Law.

In the 4th century they were dominated by Alexander's Greeks; and in the 2nd century, in the 4th century, they were dominated by Alexander's Greeks.

allied with the Romans against the Greeks (140 B.C.). After the death of Julius Caesar the Senate of Rome granted the title of king of Judea to Herod I, in 37 B.C. B.C. and in the first year of the Christian era (or in 4 B.C. if you will) the Savior, Jesus of Nazareth the Christ, was born.

After Herod I the Romans took away from the chosen people the possibility of having a king of their lineage and placed in power a series of procurators who tried vainly to dominate the growing social agitation. The "crucifixion of Jesus Christ" (which did not exist) or the "fight against the Christians" that are usually given as an explanation for the bellicose and suicidal attitude of the Jews, are not correct; the real cause of the unrest being the fact, sensed by all members of the sacred race, that the Hebrew archetype "would be thrown to the Gentiles". It was palpable to them, by virtue of sharing the substance of the Demiurge, the Judaizing action that would henceforth take place over the whole world. What was not so clear to them was: how, after the presence of Jesus Christ, could the old covenant with Jehovah-Satan, the promise that the sacred lineage would inherit power over the other nations, be fulfilled? It would take several centuries and the work of eminent Kabbalistic rabbis for the Hebrews to recover their faith about their role in history. But while this time was coming, the patience of the Romans ran out long before; in 70 A.D. General Titus destroyed Jerusalem, the Temple of Solomon, and "dispersed" the Jews to all corners of the Roman Empire. With the Diaspora of the year 70 begins the modern history of the chosen people, whose culmination is about to take place in our days, when the Synarchy transfers in their hands the totality of the world power.

When in 313 the Emperor Constantine the Great recognized Christianity as the official religion of the Roman Empire, a difficult period began for the Slavic race. The reason was that in the recently Christianized peoples the blood memory of Christ-Lucifer predominated more than the Jewish archetype of Jesus-Christian, a fact that almost always led to a generalized anti-Jewish sentiment. Although in the long run the permanent influence of the "geocentric ray" of Jesus-Christ would eventually triumph over the hyperborean memory, and the masses would end up Judaized, meanwhile the sacred race would run the risk of being exterminated. But the "threat" would soon be averted.

Whether there really existed an effective danger against the Hebrews is something to be doubted, since in the 5th century Saint Benedict of Nursia founded the order into which the "Christian" Druids joined en masse, and who from that time on would dedicate themselves to the task of mediating between the Church and the Synagogue. (Regarding the mediating and protective action of the Druids towards the Hebrews, I agree with the theory of Professor Ramirez, of the



University of Salta, exposed my neffe Arturo Siegnagel. However, the mission of the Druids went much further, as will be seen, than the simple protection of the sacred race).

We said that the Tablets of the Law remained where Solomon had kept them and were only found in the Middle Ages, more precisely in the twelfth century. Our answer does not conclude with this statement; we will have to return very soon, in the next paragraph, to continue with the story. In the meantime, let us try to find an answer to the first part of the question: what has become of the Gral....?

Contrary to the question of the Tablets of the Law, which obliged us to refer to historical facts, the question of the Gral will lead us to strictly esoteric terrain. But first of all, it should be made clear that the question has been badly posed. We have already explained that the Gral is not to be sought; let us now add that it is an object which cannot be appropriated and which, therefore, must still be where it has always been. It is a mistake, then, both to "seek" the Gral and to ask: what has become of him? But, we may ask ourselves, how should we approach this Mystery, then, in order to obtain some additional knowledge, free of paradoxes? The only way, in our opinion, to advance in the knowledge of the Mystery consists in deepening the analogies that link the "orienting function towards the origin" of the Gral, an external function, with the "secret ways of spiritual liberation" of the Hyperborean Wisdom, which are internal functions, "orienting towards the origin".

In this sense we can establish a very significant analogy between the "Pie dra Gral" of Strategy "O" and the "lapis oppositionis" used in the way of "strategic opposition".

In the chapter that we have dedicated to the A1 Strategy of John Dee, a description was made of the secret ritual practiced by the berserkir of the S.D.A., based on the way of strategic opposition and the archemonic technique. The arche- mona that the berserkir had built in the underground crypt, consisting of a "square" or area enclosed by a ring of water, was shown there.<sup>1</sup> By applying the "law of enclosure" to the arch mona, it is possible to ISOLATE the square of the Valplads; that is to say, it is possible to FREE AN AREA

---

1 *The application by the ancient Hyperborean lineages of this strategic formula has been converted in the Bible into the fable that Cain was the first who "fenced off an area and walled it in" (within which he built cities whose economy was based on Agriculture).*

in the world of the Demiurge. But this is not enough; it is necessary for the berserkir to desynchronize themselves from the time of the world and generate a time of their own, inverse, that allows them to DIRECT THEMSELVES TOWARDS THE ORIGIN. For this they practice the STRATEGIC OPPOSITION AGAINST THE LAPIS OPPOSITIONIS, WHICH ARE SITUATED ON A RUNE IN THE VALPLADS, IN FRONT OF THE FENESTRA INFERNALIS.

It is now our turn to approach the greatest secret, that which explains the method employed by the Siddhas to MAINTAIN, permanently, eternally if you will, the Gral in the world. Let us begin by inquiring into the following: what is the RESIDENCE of the Siddhas? We can start from a known answer, which we have repeated many times: The Siddhas reside in Valhalla. Such an answer is correct, but insufficient; for one could ask in turn, what is Valhalla, where is it located? Faced with these questions, two criteria can be adopted; one, to resort to elements of Norse mythology and say, for example, that "at the top of the Iggdrasil ash tree is Valhalla, the place where the warriors killed in battle go to reside, ruled by Wotan, etc.". And a second criterion, which seems to us more accurate, consisting in stripping the answers of folkloric ornaments and expressing them with symbols of the Hyperborean Wisdom, which can be easily interpreted by means of analogies.

With this criterion we can immediately affirm that the Valhalla IS THE SIDDHAS (or Aces) RELEASED SQUARE SOMEWHERE IN THE UNIVERSE OF THE ONE. This square, naturally, has the dimensions of a country and is strongly fortified. In it dwell the Lords of Venus and very many Siddhas and Walkirias, who are permanently preparing for battle while awaiting the end of the Kaly Yuga and the awakening of the captive spirits. Their countless warrior Siddhas, immortalized with their vakra bodies, form in the ranks of the WildesHeer the furious army of Wotan, and guard the walls of Valhalla, although the enemy would never dare to face such a fearsome hyperborean garrison.

The Siddhas have liberated the stronghold of Valhalla by applying, with their Mighty Wills, the law of the encirclement of the stone walls. The conquest of their own time which reigns in Valhalla, and which makes them independent of any "cycle" or "law" of the world of the Demiurge, comes from a marvelous operation of strategic opposition. But what was the stone, the lapis oppositionis that the Siddhas used in their Hyperborean Strategy? Since the Conflict of the Origins, millions of years ago, the Siddhas have been practicing strategic opposition AGAINST AN EXTRATERRESTRIAL PRECIOUS GEM FACILITATED FOR THAT PURPOSE BY THE GALLARD LORD, CHRIST-LUCIFER. "THAT STONE IS CALLED GRAL".

The analogical relationship between archimona and Valhalla becomes even more evident if we consider that the latter has a "PORTA INFERNALIS", equivalent to the "FENES- TRA INFERNALIS" of the former. The porta infernalis is an opening in the wall that is permanently guarded by attentive sentries. In front of the porta infernalis, but outside the Valhalla, that is to say, in "the world", THE GRAL IS SITUATED ON A RUNE; against it, as has been said, the Siddhas practice strategic opposition.

It is necessary to go a little deeper into the description of this provision because of its extraordinary importance for the approach to the Mystery of Gen.

In the crypt of the S.D.A. the lapis oppositionis were placed ON silver runes ENGRAVED IN THE FLOOR SLATES. Similarly, the Gral, as a lapis opposi- tionis, WAS ORIGINALLY PLACED ON A RUNE AND IT IS STILL THERE: ON

THE RUNE AND IN THE ORIGIN. This is not a play on words but a property of the Gral that must be carefully examined: the Gral, as a reflection of the origin, cannot become in time like the material "things" created by the Demiurge; in other words, the Gral cannot be in the present. In truth, the Gral is in the remote past, in that time and place in which he was co-located, and therefore he MUST NOT BE SEARCHED by employing "movement" (and time) to obtain him, for such an attitude POINTS TOWARD THE FUTURE, that is, in the opposite direction, as we have already explained. But if the Gral is in the past, if time does not drag it to the present with its uncontainable flow as it happens with material objects, and it HAS ALWAYS REMAINED THERE (in the past), how is it that we have come to know about it? And most importantly, how can it ACT in the present, as Strategy "O" PRESCINDING TIME demands? In other words,

By virtue of what "element" is the Gral connected "from the past" with "the present", for example, with a hyperborean leader? The solution to these problems has since ancient times been a dangerous secret ... which we will now try to reveal. The enigma is solved by reasoning in this way: although the Gral HAS ALWAYS REMAINED IN THE PAST, a property that only the Gem of Christ-Lucifer possesses in the Universe, THE SAME HAS NOT HAPPENED WITH THE RUNE THAT SUPPORTS HIM.

(and still sustains it). Here is the great secret: while the Gral, reflection of the divine origin, remains as such "SITUATED AT THE ORIGIN", the rune on which it was established has crossed the millennia and has reached the present. By the way, the rune is "always present", which means: "in any historical circumstance". Let's talk a little about the rune.

It is known as the RUNE OF ORIGIN or the RUNE OF GOLD, but we must clarify that such names not only designate the "symbol" of the rune but also the TERRESTRIAL FOOT which was the primordial seat of the Gral. Therefore, when in the Hyperborean Wisdom allusion is made to "the Rune of Gold", what we are really dealing with is a very ancient stone, violet blue in color, in which the Siddhas set a runic sign of gold. It is therefore necessary to know the origin of the stone and the reason for its construction.

We have already mentioned on other occasions that in the beginning the Siddhas entered the Solar System "through the door of Venus" and that a group of them, the "Traitor Siddhas", "associated" with the Plan of the Demiurge, provoking later, in combination with the latter, the catastrophe of the captive spirits. The Hyperborean spirits were enca- dined to matter by having fallen into a cosmic trap, the Mystery of Love; but we will not speak of it for the moment. The effect produced in the evolutionary world of the Demiurge by the assimilation of the confused spirits is what we would call today: a collective mutation. To the evil of the imitative arrangement of matter, made by the Demiurge, was then added the evil of the mutation of his Work and the enchainment of the spirits, that is to say, the modification of the Plan made by the Traitor Siddhas. And in order to "control" such an evil enterprise, the Traitor Siddhas decide to found the White Hierarchy, in which the different devic manifestations of the Demiurge must be organized. The "headquarters" of Power, Chang Shambala, is also the key to the collective mutation of the seven kingdoms of nature. Indeed, in what way did the Demiurge maintain THE STABILITY OF FORM ON EARTH and how did he ensure, before the mutation, that the seven kingdoms evolved according to his Plan? There are two principles involved in the execution of the Plan, one static and the other dynamic. The Plan is supported STATICALLY by the archetypes and DYNAMICALLY by the Breath of the Solar Logos. That is to say, it was a FORCE FROM THE SUN (physical vehicle of the Solar Logos) that maintained the evolutionary impulse in the seven kingdoms of terrestrial nature. Well: to provoke any per- manent alteration in the Plan of the Demiurge, IT IS IMPERATIVE TO INTERCEPT THE ENERGETIC CURRENT FROM THE SUN, WHICH, CROSSING THE OCEAN OF PRANA, PROCEEDS THE OCEAN OF PRANA, CONVERGES ON THE EARTH. To fulfill this condition, the Brought Siddhas installed themselves from the beginning BETWEEN THE SUN AND THE EARTH, in a FIXED position that never lets even a ray of light (i.e. not even a photon) pass without first being intercepted. This statement may seem fantastic, and indeed it is; but more fantastic and foolish has been the construction of Chang Shambala, since what we have described is the "technical" function of the seat of the Power of the Traitor Siddhas.

Here is another "secret" that is no longer a secret, the "location" of Chang

Shambalá has become a "secret".  
can now be determined from this data: it is always between the earth

and the Sun. Actually, Chang Shambala is very close to the earth, which will give an idea of its enormous size. However, this is not a whim, but it must have been built this way due to the requirements of its MODULATING function of the solar gene plasma.

Of course, there will be those who will foolishly say that all this is nonsense, given that "the traditions of Tibet and India" state that Chang Shambhala "is a kingdom situated in Asia, between the Altai Mountains, the Gobi Desert and the Himalayas". Undoubtedly, such a comment would constitute a greater nonsense than our claims. In the first place, the so-called "traditions of Tibet and India" are the product of the strategic disinformation that for centuries the Hierarchy has been disinforming so that the truth will be ignored. And, secondly, let us say that the most serious data of the Tradition (for there is some credible data) always mentions THE LOCATION OF THE GATE OF CHANG SHAMBALA and never the kingdom itself. This subtle distinction is highly suggestive, because the fact that in a certain geographical location there is a gate DOES NOT IMPLY THAT THE KINGDOM IS IMMEDIATELY BEHIND IT! A primitive mind, influenced by the belief that the straight line is the shortest distance between two points, might understand it this way, and in fact such a thing frequently occurs. But here we are handling the information on another level and therefore we will repeat four verses from the Song of Princess Isa, which we already had the opportunity to know when we studied the story of Nimrod the Defeated:

*"But, although Dejung is far away,  
its gates are everywhere. Seven  
gates Dejung has,  
and seven walls surround it".*

These "induced gates" are referred to in oriental legends, which "are everywhere" and lead to the kingdom which, evidently, does not occupy a simple geographical location.

Our reference to such remote events (the perverse association between the Traitor Siddhas and the Demiurge) was intended to serve as an introduction to a fact which we will now emphasize: when the Demiurge agrees with the Traitor Siddhas to cede control of the Hierarchy to them, he gives them THE TIPHE- RETH SIGN, which represents one of the ten sephiroth and allows total control over the FORMAL aspects of creation. The sign tiphereth is the symbolic expression of the "material manifestation of the divine archetypes", an aspect usually synthesized as "BEAUTY OF THE DEMIURG". In case it has not been well understood, it is convenient to

to repeat that the Demons of Chang Shambala were left in possession of a sign that represents ALL the tiphereth aspect of the Demiurge, allowing them to access it and share its power. Naturally the sign tiphereth is the key to Maya, the illusion of the real, and therefore the most terrible tool of sorcery. Whoever observes the sign tiphereth, which is quite complex, "from the world", i.e. karmically incarnated, runs the risk of immediately becoming abyssed, losing all points of reference and therefore reason. For this reason, the Hyperborean Wisdom recommends applying the law of encirclement to the sign tiphereth in order to obtain it without danger. It is worth noting that in any hyperborean offensive against the demons of Chang Shambala, sooner or later there is a confrontation with the sign tiphereth, since one relies on its nefarious influence to defeat the viryas.

After the Traitor Siddhas received the sign tiphereth and built Chang Shambala, it was no longer possible for the Hyperborean Siddhas to remain on the surface of the Earth. But neither did they wish to leave the Solar System, leaving billions of captive spirits behind them. And so they planned Strategy "O". But before that, what was the picture of a captive spirit: basically the loss of the Vril and the consequent unconsciousness, i.e., the loss of one's own time. The enchainment to matter starts fundamentally from the enchainment to the "immanent flow of the consciousness of the Demiurge", that is, from the synchronization to the Time of the World. The captive spirits, bound to Time, would take thousands of years to recover their consciousness, if they ever succeeded in doing so. In these circumstances the Siddhas, in a marvelous display of courage and fearlessness, begin Strategy "O".

The first problem they had to face was to remain "independent" of Time, but not "outside of it," for they would have to follow closely the misadventures of the captive spirits to help them avoid strategic confusion and, eventually, to rescue them. On the other hand, the independence of time was necessary for the Siddhas to preserve their own time, their consciousness of origin, otherwise they would also run the risk of falling into the Great Delusion. But as long as the aeons succeeded one another, the Siddhas should have a pleasant place, fit to be occupied and defended by a garrison of terrible warriors from the East. These were the main problems; there were others, but we will pass over them for the sake of brevity.

The procedure to be followed was as follows. The Siddhas sought a site on Earth suitable for their purposes. As such a site WAS TO DISAPPEAR after the strategic opposition, they did not choose it WITHIN A CONTINENT as this would have been the only way for the Siddhas to find it.

The first time that the island was discovered, it would perhaps have caused a cataclysm (which would have further delayed the fate of the captive spirits). Instead, they searched among the islands and chose one of them, located in what today would be the extreme north, but which in those days was a tropical zone, proceeding immediately to ENCLOSE IT. Being an enormous island, the work to be done to build a cyclopean stone wall around its entire perimeter would seem today an impossible task. But the Hyperborean Wisdom that the Siddhas had at their disposal gave them the solutions to quickly finish such work and in a short time a colossal wall transformed the paradisiacal island into an impregnable fortress. It is not possible to describe the extraterrestrial architecture of the walls, because we would get lost in explanations and we would not advance much; we will only say that, in some sections, the construction was similar to the pre-Inca fortress of SACSABUAMAN (near Cuzco, in Peru), but such similarity, we must also say, was very close because Sacsayhuaman is still TOO HUMAN.

Only one opening was made in the wall, which will surprise those who do not know the strategic principles of the Hyperborean Wisdom. And outside this opening, which we have already named with a modern denomination: PORTA INFER-NALIS, the GOLDEN RUNE was placed. The time has come, then, to return to the greatest Mystery.

The Great Chief, Christ-Lucifer, boldly installed in an unthinkable place, behind Venus, as the Black Sun or expression of the Origin, decided to respond to the vile conspiracy of the Traitor Siddhas with an act of war. It was to fulfill His Will that the Hyperborean Siddhas occupied the island and walled it off, initiating Strategy "O". But Strategy "O" was intended to "awaken" and "orient" the viryas, individually or racially, as we have already said; then, what was the "act of war" with which Christ-Lucifer responded to the betrayal of the Siddhas of Chang Shambala? Concretely: the war coup was given by Gen.

The hyperborean gem, removed from the forehead of the Gallant Lord and settled in the world of the Demiurge, would prevent the Demons from denying the divine origin of the spirit, since its tarnishless brightness would at all times give off the reflections of the Primordial Homeland. The Gral, by divinizing the hyperborean lineages, constituted the greatest challenge; for he threatened to send the infernal plans to failure. The conflict would be, from then on, eternally posed by anyone who managed to awaken, whatever the hell he was in, since the Gral would be seated in the physical plane, that is, in the lowest of the infernal regions, and HIS SHINE WOULD BE SEEN FROM EVERY CORNER OF THE WORLD, including the astral plane and all those "purgatories" that the Demons prepare there to deceive the spirits; even on those very subtle planes of the monads emanated by the Demiurge, where also



There are also completely idiotized hyperborean spirits, who have been made to believe that "they must remain there while their denser 'other bodies' evolve". Finally, the Gral was, if we may use the metaphor, a gauntlet thrown in the face of the Demons, for a challenge to which they, in their cowardice, would not be able to respond.

But it was not so easy to make the Gral, once he had entered the physical plane, remain simply located in one place, for example, on an altar. Because of its timeless character, as a reflection of the Origin, the Gral, as a true uni- versal diluent, would pass through everything and would be lost from sight ... especially if for those who looked at it the TIME OF THE WORLD PASSED. The Gral cannot be seated on any substance that flows at the impulse of the Breath of the Logos, that is, that flows temporarily, for it would be lost IN THE PAST, SINCE ITS ESSENCE IS ALWAYS IN THE ORIGIN. What to do? It is necessary to "prepare" a material seat in such a way as to support it (the Gral) EVEN IF IT REMAINS IN THE PAST AND EVEN IF THE TIME OF THE WORLD EFFECTIVELY PASSES FOR THAT SEAT. Can such a thing be constructed? Only if between the substance of the seat and the Gral a sign THAT NEUTRALIZES TEMPORALITY is inserted. This means that the sign must represent THE MOVEMENT REVERSE to that employed by the Demiurge to construct the Solar System.<sup>1</sup> Such a sign, which is the height of heretical symbols, was employed by the Siddhas to construct the seat of the Gral, which we have called the GOLDEN RUNE.

Attention to this because we will say it only once: FROM THE GOLDEN RUNE, which is a very complex sign and of tremendous magical power, IS DERIVED, PREVIOUSLY MUTILIZED AND DEFORMED, THE SWASTIKA RUNE, about which so much nonsense has been written.

A violet blue crystalline stone, similar to an agate, was chosen to build the seat of the General. In its upper part, in a slightly concave area, a golden rune was skillfully chiseled by the Siddhas. And once the seat was completed, it was deposited outside the walls of the island, in the direction of the porta infernalis, but many miles away, in a continental region.

It will be difficult for anyone to imagine the marvelous spectacle of the General descending into the seven hells. Perhaps if one thinks of a green ray, of blinding brightness and Gnostic influence over the seer, before whom the Demons turn their

---

1 *Physical motions must be ruled out:  $e = dv/dc$ . Here we refer to*

**Nimrod from**

**Rosario**

*"another kind of movement".*

The fierce faces frozen with fright; a thunderbolt which, like the blinding blade of an invincible sword, tears through the four hundred thousand worlds of Deception seeking the heart of the enemy; a green flying serpent bearing between its teeth the fruit of Truth, hitherto denied and hidden; if one thinks of the thunderbolt, the sword, the fruit, the serpent, it may be possible to intuit what happened at that crucial moment when the truth was placed within the reach of the captive spirits. Yes, because since the Gral settled on the Golden Rune, the Tree of Science was planted within the reach of those who, completely confused, lived in hell believing to inhabit a paradise. From now on they could eat of its fruit and their eyes would be opened!

Hallelujah for Christ-Lucifer, the Serpent of Paradise! Hallelujah for those who ate of the forbidden fruit: the awakened and transmuted viryas!

What was the next step of the Siddhas? Prior to the fall of the Gral, but when this phenomenon was already occurring on other planes, they applied the law of encirclement to the walls of the island ISOLATING THE INSIDE AREA FROM THE OUTSIDE. To understand the effect that such a strategic action produced, it must be kept in mind that THIS WAS THE FIRST TIME THAT A PLACE IN THE SOLAR SYSTEM WAS RELEASED.

When a ring of fire seemed to burst from the imposing walls and was no longer seen towards the interior of the island, enveloped in a strange vibratory and flaming cloud, the Demiurge began to feel his substance amputated. The strategy of the Siddhas aimed at winning not only the flat area of the island but also its relief, its mountains and valleys, its lakes and forests, its vegetables and animals; the island, a vast country, was also a gigantic Noah's ark that should receive for millennia the viryas who managed to awaken and flee from the material chains and also those who had transmuted fighting to death in the battles.

A whole country subtracted from the immanent control of the Demiurge was a new experience, but, however this might have been possible, the truth is that the island was still there: hidden by a barrier of fire, but in the same place. That is why the reaction of the Demiurge made the Earth tremble, seeking to somehow affect that incomprehensible phenomenon and regain control of the "square". Terrible tidal waves shook the adjacent seas and winds never seen before blew uselessly against the titanic walls; the sky was darkened by clouds of ash from suddenly awakened volcanoes and the bottom of the ocean threatened to split and try to swallow the "liberated" island.

The world seemed to have gone mad, displaying the terrifying spectacle of all the forces of nature "unchecked" when, "as if it were the last straw

of abominations", the Gral descended upon the Earth.<sup>1</sup>

What could we add to give an idea of what happened there? We have already said that it is very difficult to describe (and even mention) an event that generated a perpetual irritation in the Demons. Perhaps this comment will say something to someone, which we doubt: "as the Gral fell upon the Earth, beyond the three hundred and seventy times ten thousand worlds, the Great Face of the Ancient One uttered a howl of horror that IS STILL HEARD REVERBERING in the confines of the cosmos".

As soon as the Gral had settled on the Golden Rune, the Siddhas practiced the strategic opposition, making the walled island become invisible, disappearing forever from the earth's surface. From then on, sleeping men would speak of Valhalla, the abode of the Gods, and also of Hyperborea, the "island swallowed by the sea", since the original myth, charismatically transmitted by the Siddhas, has suffered different falls in exotericism due to the blood impurity of the viryas.

The question that initiated the preceding esoteric commentary, let us remember, said: what has become of Gral ....? As an answer we obtained that it is wrong to inquire about the Gral, since it is virtually THE ORIGIN, and has never moved from there. Its seat, on the other hand, the Golden Rune, has the dimensions of a material object and it is to be assumed that, to a great extent, it is affected by physical laws. We can then restate the problem: What has become of the Golden Rune? Does it still hold the Christ-Lucifer gem? In the latter case the answer is affirmative: the Golden Rune has been since then the seat of the Gral, a situation that has not changed at all in modern times. As for the first question, we must understand that it would be an impossible task to summarize here the complete history followed by the Golden Rune up to the present day; this would force us to mention civilizations that have disappeared and, many of them, are completely unknown to the official culture. We will then refer to historical times, beginning by establishing some guidelines that will allow us to approach the problem correctly, thus avoiding many superstitions or misinformation.

1 - The Golden Rune has often been confused with the Gral. Indeed, we have already explained why the Gral should not be sought. However, on some occasions there really HAS BEEN TRANSPORTATION and it has been thought, with good reason, that it is

---

1 *According to the Hyperborean Wisdom, "two WINGED Siddhas, lieutenants of Christ-Lucifer, accompanied the General in his descent".*

But the Gral is NOT AN OBJECT THAT ONE CAN APPROPRIATE, AND EVEN LESS TO MANIPULATE OR TRANSPORT. In all plausibility, what has been transported is the Golden Rune, within the framework of a racial Strategy. In this case, we cannot attribute the confusion solely to the enemy's strategic action because, in the degradation of the ancient Hyperborean myths, the major responsibility falls on the blood impurity of the viryas.

2º - The presence of the Golden Rune among the members of a community of hyperborean language has the virtue of favoring the charismatic bonding and legalizing the leadership of its leaders.

3º - The presence of the Golden Rune is the presence of the Gral; and the people to whom the Siddhas have entrusted its custody is WITHOUT DOUBT, at that moment, the purest hyperborean lineage of the Earth.

4º - To certify if a certain town has been in possession of the Golden Rune, it is necessary to study its hyperborean architecture of war: THE POSSESSION OF THE GOLDEN RUNE REQUIRES THE CONSTRUCTION OF STONE STRUCTURES WITH PECU.

THE SAME TOPOLOGICAL PROPERTIES. Such constructions may NOT LOOK as if they were made for war, but such appearance is due exclusively to the ignorance that exists about the Hyperborean Strategy. An example is the "castle" of Montségur, on Mount Thabor, in the French Languedoc. This construction, which is far from being a fortress, was erected to allow the Hyperborean sect of the Cathars to RECEIVE AND PRESERVE the Golden Rune. The principles that prevail there are those of the "law of encirclement" and of "strategic opposition", it being a useless task to pretend to make of Montségur an astronomical observatory or a solar temple. But as the architecture of Montségur has been projected IN FUNCTION of the Golden Rune, whoever does not pay attention to this key will never reach any positive result.

5º - It is necessary to distinguish between the seat of the Gral, which we call Golden Rune, and the Sign of the Origin, which the Golden Rune represents. We said that in the violet blue stone the Siddhas set a golden figure and we call the whole (stone and figure) Golden Rune. But the Sign of Origin, which was chiseled in gold and set, possesses by itself the particular power of presenting "affinity" with the Gral. That is why many Hyperborean lineages, which did not attain the high honor of guarding the Golden Rune, received instead the Sign of Origin as a reward for their purity of blood and recognition of the effort put into their Strategy. This is how the Sign of Origin had, in the course of history, a particular proliferation among certain lineages that proudly incorporated it into their banners. Naturally-

At first, the leaders tried to partially veil its symbolic content by simplifying the figure, that is, by removing some suggestive elements; but, after the fall into exotericism and vulgarization, THE TRUE ASPECT of the Sign of the Origin was forgotten; we have already said, for example, that the Swastika proceeds by mutilation and deformation of that primordial sign.

However, in many cases, due to the extraordinary blood purity of some lineage, the Sign of Origin was displayed in full, enabling the leaders to employ their enormous power to project the light of the Gral over the mass of the people. We could give several examples of Asian communities bearing the Sign, but we have at hand the case of the SAJONES who had engraved the Sign of Origin on a tree trunk which they considered the column of the world (UNIVERSALIS COLUMNA). The purpose of such an audacious determination deserves also a comment.

When in 772 Charlemagne conquered Erbury, he quickly proceeded to destroy the IRMINSUL stock and to execute five thousand members of the Saxon nobility. Not content with this, after three decades of heroic resistance, the Saxon race, of pure Hyperborean lineage, was totally "Christianized" (after the execution of its purest offspring). We have learned that many educated Germans consider this dreadful Carolingian campaign "fortunate". Thus Professor Haller is unashamedly of the opinion that *"without the submission of the Saxons there would be no German nation today"*<sup>1</sup> ; for *"for the historical development of the German nation as it is today, the incorporation of the Saxons into Charlemagne's empire was an indispensable precondition"*<sup>2</sup> . This generalized opinion is based on the "a posteriori" analysis of historical facts and therefore, considering that the extinction of the Carolingian dynasty made it possible that two hundred years later the Saxon blood arrived with OTHON I to take the lead in the Western world, it is taken for granted that the domination and "conversion" of the Saxons was "necessary" and positive. Here is OUR opinion: The Judeo-Christianization of the Saxons represents the hardest blow that the Infernal Powers dealt to the Hyperborean lineages in the Christian era, even greater than the conversion of the Vikings, the Celts or the destruction of the Cathars, only comparable to the annihilation of the Gothic kingdoms. And the destruction of the IRMINSUL tree, with the loss of the Sign of Origin for the West, is a catastrophe very difficult to evaluate.

6º - It is not essential, nor even necessary, that the Golden Rune be found in the bosom of a people for the influence of the Gral to act upon it. The Gral

---

1 Prof. Johannes Haller - *The Entry of the Germans into History* - Page 99,

*U.T.H.A., Mexico.*

2        *Haller - OP.CIT. P. 101.*

acts upon the viryas FROM THE ORIGIN, a property which cannot be affected by any physical variable, wherever the Golden Rune is found. It is therefore to a certain extent absurd to attribute to this or that people to have reached "a high degree of civilization" because "they were in possession of the Gral"; since the Gral cannot be in the possession of anyone, for it is, by the disposition of the Lord Gallar, proof of the divinity of ALL captive spirits. What a people can have IN CUSTODY is the Rune of Gold, but only as a reward and recognition of a racial purity obtained PREVIOUSLY. That is to say that the fact of having in custody the Golden Rune is not the cause of the greatness of a people, but, rather, the purity of its lineage made it worthy of the high honor of being the depositary of the seat of the General. But, although the Golden Rune is ONLY GIVEN TO THOSE WHO DESERVE TO HAVE IT, it is certain that its close presence affects the environment creating a mutant microclimate. That is why the Siddhas usually deposit the Golden Rune, during the dark ages, in appropriate places to influence the less confused lineages.

7º - From all that has been exposed up to this point, we can deduce the capital importance that it would have for a community of hyperborean lineage to obtain the custody of the Golden Rune. It is therefore necessary to deal in detail with this possibility, which we will do in the next chapter when dealing with the A2 Strategy of the Siddhas. However, before considering Strategy A2, we must be clear about a fundamental concept, which is readily apparent from the preceding conclusions. The problem can be summarized in the question: why does "the king" (or whoever holds the regal function) need to find the Gral (i.e. the Golden Rune)? Next, we will invite a brief reflection on the attitude that should be adopted when taking knowledge of the events of the Siddhas; and then we will give an answer to the problem by delving a little deeper into the symbolism of the Gral.

A deep meditation on the symbols we are presenting is required to grasp their ultimate content, which must always be perceived as dramatic and tragic, full of spiritual urgencies. No one who has become aware of the incredible sacrifice made by the Siddhas in maintaining the Gral in the world for millions of years through strategic opposition, that is, through a constant and continuous act of Will; no one who has understood this, we repeat, can remain impassive, in the midst of confusion, without experiencing the urgency to free himself from the chains of the Demiurge and leave, trying to alleviate, in some way, the task of the Siddhas. No one who proves with his blood the truth of these symbols can avoid that honor, the only morality of the virya, urges him insistently to "abandon everything" and leave. But that departure will be "with weapons in hand", like Nimrod and Wildejäger, ready to give battle without quarter to the Demons and feeling that he will be able to "leave everything".



that the blood has been ignited by the "berserkir fury", by the "original hostility" towards the Work of the Demiurge, transmuting the weak organic substance of the physical body into vraja, the incorruptible matter. It is the least that the virya can do to respond in some measure to the help that the Siddhas have given to the Hyperborean lineages, making it possible with their Hyperborean Strategy that the Gral GIVES PROOF OF THE DIVINE ORIGIN.

Let us now turn to the pending question.

The Stone-Grail, the gem of Christ-Lucifer, IS HOLD IN THE WORLD BY THE OPPOSITION OF THE SIDDHAS, where it fulfills its function of reflecting the Origin and divinizing the Hyperborean lineages; but, because IT IS TEMPORARILY RELATED TO THE VALHALA, it also points out to every liberated virya a path towards the abode of the Immortals. That path is the one followed by the warriors fallen in battle, the heroes, the champions, guided by the Hyperborean women, those that were given to them at the beginning of time and that for thousands of years, because of the FEAR that poisoned their blood, they had forgotten. If the courage demonstrated in the feat has been sufficient purge, unfailingly She will be there, next to the fallen warrior, to heal his wounds with the icy love of Hyperborea and guide him on the inverse path that leads to Valhalla. AND THAT PATH BEGINS IN THE GRAL.

But it should not be thought that the light of the Grail aims at the individual salvation of the lost viryas; for this purpose the "song of the Siddhas" and the seven secret ways of spiritual liberation are available. On the contrary, within the Strategy "O" the Grail must fulfill the fundamental role of RESTORING THE REGIA FUNCTION; that is, he must serve a racial or social purpose. That is why the Grail will be required in all cases in which an attempt is made to establish the Universal Empire or any other system of government based on the social application of the law of encirclement (monarchy, fascism, national socialism, aristocracy of the spirit, etc.).

The historical events leading to the "search for the Grail", always similar, can be summarized symbolically as follows. In principle the kingdom is "terra gasta" or the "king is ill" or simply the throne has been rendered acephalous, etc. (There may be many interpretations, but essentially the symbol refers to an exhaustion or decline in charismatic leadership and a vacuum of power, whether the government is exercised by a king, caste or elite). The best knights set out to "find the Grail", in an attempt to put an end to the ills afflicting the kingdom and bring back the former splendor. Only one succeeds in "finding" the Grail and restoring well-being to the kingdom, either by "healing the king" or "crowning himself". Curiously, the triumphant knight is always presented as a "fool", a "madman", a

**Nimrod from**

**Rosario**

"madman" or a "fool".

pure", "naive", but especially as "commoner".

The "best knights" are here equivalent to any of the multiple social forces that are ready to pounce on the royal function when there is a vacuum of power. Finally "one of them" triumphs and re-establishes order in the kingdom; "he was the commoner and now he is king, with the approval and consent of the people". In our interpretation this means, evidently, that one "social force" has prevailed over the others (the "other knights") and HAS REPLACED THE EXISTING ORDER (which was in question) WITH A NEW ORDER, unanimously accepted BY THE PEOPLE. But if the problem is reduced to a mere struggle for power, why does the new king (or new elite, aristocracy, caste, etc.) need to find the Gral: BECAUSE THE GRAL CONFIRMS THE ROYAL FUNCTION.

When in times of crisis a new elite or charismatic leader holds power, with intentions of royal restoration, he must hasten to LEGALIZE his situation; otherwise another elite or leader will come to question his titles and will also try to occupy the vacant place, and an endless series of battles (political or military) will ensue. But if there is a struggle for power, NO ONE HAS THEIR CONTROL; and it may happen that in the end the kingdom ends up divided among several factions. It is necessary to settle the question, to consult an infallible judge, an undisputed and transcendent authority. This is where the need to resort to the General arises. Why the General? Because the General is also the RULING TABULA, the "list of kings"; HE SAYS WHO SHOULD RULING, WHO SHOULD RULE, BECAUSE HE REVEALS WHO HAS THE PUREST BLOOD. But this revelation is not simply oracular and arcane, but through the mediation of the Gral, the purity of the leader, his right to lead, will be known by all and recognized by all, charismatically. Hence, the pure madman, of hyperborean lineage, but of plebeian lineage, after meeting the "Gral" is "recognized by the people" as undisputed king.

When a hyperborean lineage trusts in the light of the Gral for the election of its leaders, it can be said with propriety that a dynasty of "Kings of the Gral" will succeed one another. During the reign of one of these it may happen that the lineage reaches such a high degree of purity that it becomes worthy of obtaining the custody of the Golden Rune. This is what happened, for example, in the 13th century in the French county of Toulouse, when the Golden Rune was entrusted to the Perfect Cathars. (It will be argued against this statement that the Cathars were Manichaeans, that is, heirs of a Gnostic tradition, and that this is the reason why they were annihilated, there being only a circumstantial relationship between them, the Counts of Toulouse and the Occitan population. Such an argument, of Druidic-modern origin, tries to divert attention from the most important fact of the Cathar epic: their relationship with the Gral.

The fact that they taught one of the seven secret ways of liberation based on the Love Song of the Siddhas, origin of the culture of the troubadours, which few know, does not explain at all their relationship with the Gral. The Gral, in the framework of the "O" Strategy, has a purely racial meaning. If the Golden Rune was entrusted to the Cathars, it is because they actively participated in collective transmutation techniques, WHICH CANNOT EXCLUDE THE REGIONAL FUNCTION, and not simply "because they were of Gnostic affiliation").

A theme connected with the property that the Gral possesses of being Tabula Regia is that of the Imperial Messiah and his imitation, the Jewish Messiah. In principle, let us say that one is King of the Gral by purity of blood, an absolutely individual attribute that does not depend on race, nor on lineage, nor on any material patrimony. A Gral King exhibits purely personal virtues such as courage, fearlessness or honor, and never bases his prestige on material possessions or the value of gold. The authority of a Gral King, for these reasons, comes exclusively from his personal charisma, which extends to the rest of the people thanks to the "link" that is established between the King and EACH ONE OF THEM, in their blood, THROUGH THE MEDIATION OF THE GRAL: it is the principle of the psychosocial Mystique. That is why a King of the General, IN HIS COMMUNITY, is recognized by the people. Naturally, ALL PEOPLES would have their King of the Gral if the action of the Sinarchy and the Hebrew race, with its "Democracy", Socialism, Communism, etc., had not usurped the regal function. In any case, it is worth asking: would there be at the universal level for the Hyperborean lineages the possibility of a King of the Gral being recognized by all? This would be a personage of undeniable purity, whose majesty would be evident to all the lineages of the Earth, who could accept or not his power, but to whom they could not deny the right to rule. Well, it is easy to answer then, that the only Lord who accredits, for all the Hyperborean lineages, such a right, is Christ-Lucifer. If He were to appear before the Hyperborean lineages, His right to rule by blood<sup>1</sup> , based on His undeniable purity, may or may not be accepted, but never denied.

But the idea of the Imperial Messiah does not come from mere speculation. It was in the dark days of Atlantis that, in response to the clamor of the Siddhas, the possibility arose that the exalted Presence of Christ-Lucifer might manifest itself to the sight of men. In those days the confusion of the captive spirits was so complete that no one responded to the chant of the Siddhas or was able to perceive the light of the Gral. That is why the coming of the Imperial Messiah, the King of the

---

<sup>1</sup> *It never hurts to repeat that we are referring to ANOTHER BLOOD other than the physical. Until we have a better explanation, it is convenient for the reader to*

*take this "blood" in a symbolic sense.*

The prophecy was finally fulfilled with the arrival of Lucifer, the Christ of Atlantis, but His Divine Presence was cowardly resisted by the Demons of Chang Shambalá who resorted to the use of the Holy Spirit to restore the spiritual aristocracy of the Hyperborean places and to destroy the synarchic Hierarchy imposed by the Demons. The prophecy was finally fulfilled with the arrival of Lucifer, the Christ of Atlantis; but His Divine Presence was cowardly resisted by the Demons of Chang Shambala who resorted to the use of black magic and opened a breach between the infernal regions of the astral plane and the physical plane. From that point on, a terrible struggle became generalized, which only ended when the component of Atlantis "had sunk into the waters of the Ocean". It is not necessary to relate here events that nobody remembers today and that, perhaps, it is not convenient to remember. We will only add that when the Demiurge, as we have already explained, conceives the sinister idea of copying the Presence of the Christ of Atlantis, he also decides to "announce" the arrival of a "Messiah" imitating in his own way the figure of the Imperial Messiah. But the differences are enormous. Here are some of them:

1st - The Imperial Messiah comes to restore the regal function; the Hebrew Messiah comes to usurp the priestly function.

2º - The Imperial Messiah accredits his right BY BLOOD; the Hebrew Messiah accredits his right BY HEART.

3º - That is why the Imperial Messiah will be recognized by the people BY THE BLOOD (charismatically); that is why the Hebrew Messiah will be recognized by the people (Jewish) BY THE HEART (emotionally).

We pose a question: what has become of the Gral and its imitation, the Tablets of the Law, and we provide several elements that contribute to its answer. In summary, we have said that the Gral, from the origin, still rests on the Golden Rune, and we mention that the latter was given in custody, in the 13th century, to the Cathars of the French Lan- guedoc. What has become of the Golden Rune since then? This is what we will try to answer in the following paragraphs when we will expose the A2 Strategy of the Siddhas. And about the Tablets of the Law we said that they remained for twenty-one centuries buried under the ruins of the Temple of Solomon, in Jerusalem, where they were found in the twelfth century. We will also talk about this discovery and subsequent fate in the following paragraphs.

Strategy "O" is a "general" or totalizing strategy; Strategies A1 and A2 are

"partial" or field strategies. Strategy A1, which we initially attributed to John Dee and Wilhelm von Rosenberg, and which was indeed designed by them as we have seen in the previous chapter, was eventually connected with

another field strategy, much earlier, thanks to the Scroll of Genghis Khan. This other strategy, which we have called "A2" for the sake of simplicity, is carried out IN HISTORY until the middle of the 13th century. From that moment on it lost its validity (because it failed to achieve its objective) and it was not until the 17th century, with Strategy A1, that SOME OF ITS GUIDELINES EMERGED ON THE SURFACE OF HISTORY.

We must note very clearly that the General Strategy "O", which is esoteric and transcendent, differs fundamentally from the Partial Strategies A1 and A2 in that the latter are dynamically directed to IMPACT HISTORY. In other words, A1 and A2 are strategies that attempt to divert the "long term" social variables to force the restoration of the regal function; they rely on the action of hyperborean leaders who charismatically guide their people against the synarchic plans, using war if necessary. These strategies, then, are related to that "racial and collective" part of the Strategy "O", that is, with the functions of the Gral. Strategy A2, especially, has had to do with the last historical destiny of the Golden Rune, as we will see next.

In order to interpret without misunderstanding the role that Strategy A2 has played in history, which we are now going to develop, we have synthesized the main arguments in some graphs. Figure 1 shows how events would have unfolded if Strategy A2 had triumphed; Figure 2, on the other hand, shows the actual strategic situation in the year 1250. For the time being, we will comment on Strategy A2 by referring to these figures; and later, when it is the turn of Strategy A1, we will use other equally synthetic graphics.

*The castle of Montsegur (Montségur in French) is located in the French commune of Montsegur, in the French department of Ariège, at the top of the Pog mountain, 1207 meters high.*



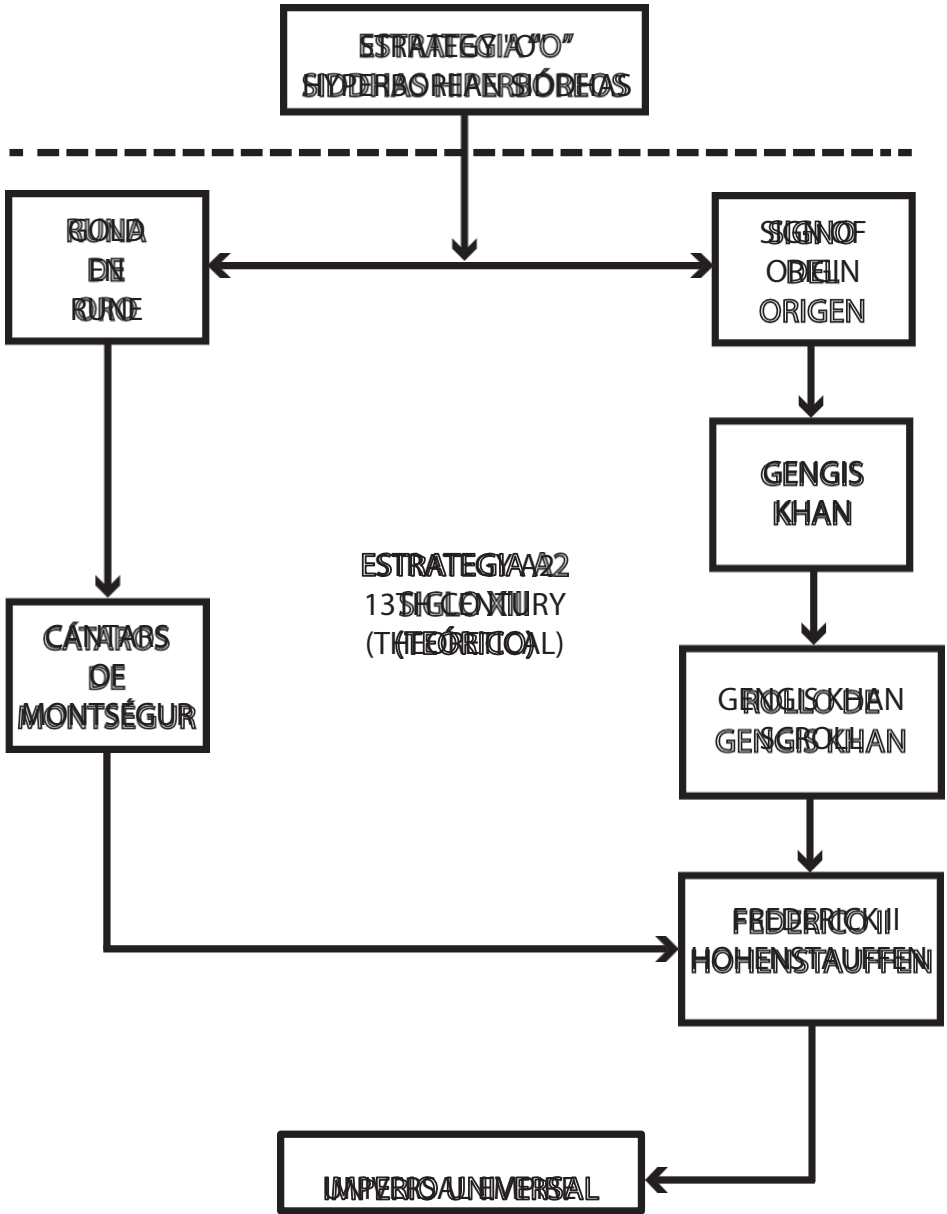

FIGURE 1.- "This is how historical events should have unfolded".

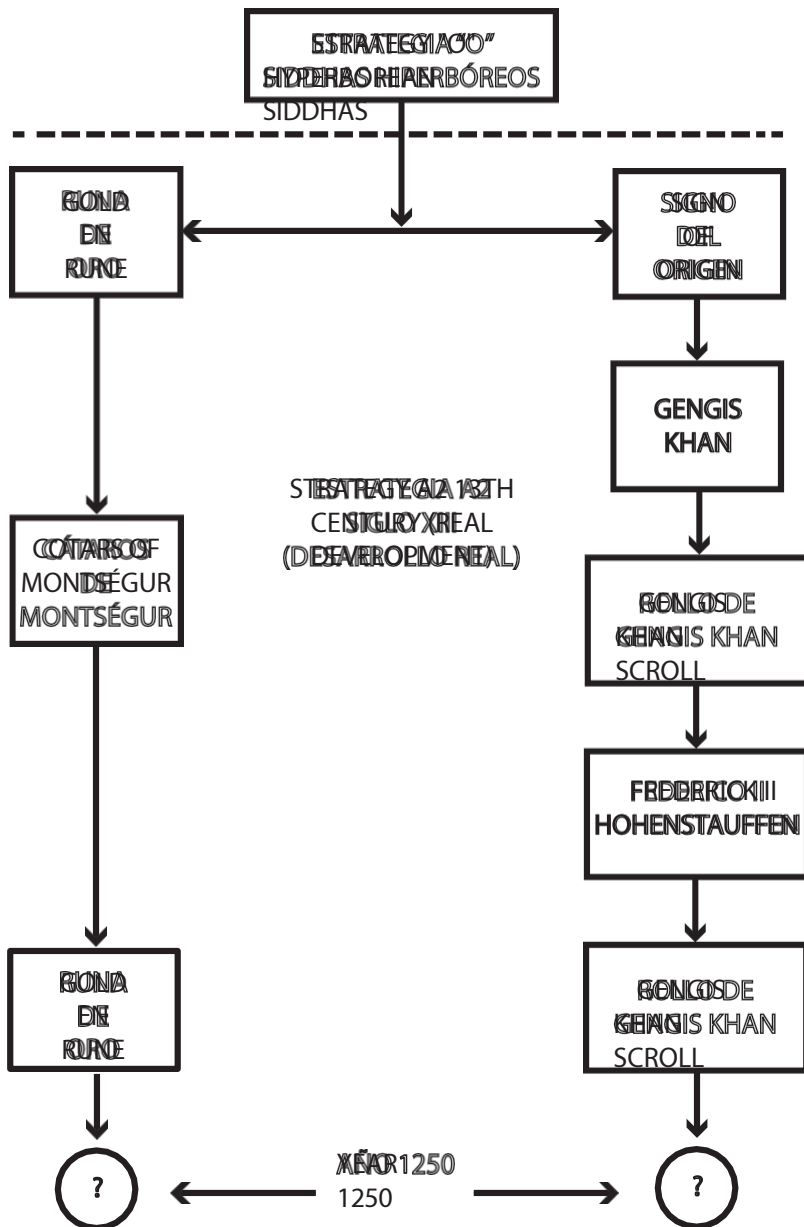

FIGURE 2.- "On the other hand, historical events happened like this...".

## INTRODUCTION TO STRATEGY A2

Before considering the concrete facts that constitute the development of Strategy A2, it will be convenient, as we have done in other parts of this work, to previously expose some concepts of the Hyperborean Wisdom that will facilitate the understanding of the subject.

If we look at Figure 1, we can see that Strategy "O" has promoted two "lines of action": one clearly Western, beginning with the delivery of the Golden Rune to the Cathars of Montségur for their custody; and the other Asian-Western, beginning when Genghis Khan receives the Sign of Origin. This second line, and in general the whole A2 Strategy, are based on a principle of the Hyperborean Wisdom concerning the mission that corresponds to the Mongolian peoples in History. We must therefore know this principle and also define what is to be understood by "Mongolian peoples". But that is not all: in knowing the mission of the Mongols, we will wonder about the true meaning of the name "Kaly Yuga", by which the present era is called; and such a question will force us to reflect at length on the modern concepts of "Historical Age" and "History" before arriving at a definition that clearly expresses the Hyperborean concept of the Kaly Yuga.

These and other matters of similar importance will be the subject of the Introduction. At the conclusion of the Introduction, the facts involved in the A2 Strategy will be briefly recounted and, thanks to what has been seen here, will be easily understood.

1 - By "Mongols" should be understood not only a racial community with defined ethnic characteristics, but also those peoples who, possessing such ethnic characteristics, have inhabited the territory of Mongolia since ancient times, that is, in that desiccated sea between the Altai, Khangai, Sayansk and Tannu Ola mountains and the Gobi desert in the south-east of the country. According to this criterion, those ethnic groups that have left their primitive settlement in Mongolia by emigration, for example, the Huns, Bulgars, Turkmen, etc., will also be considered "mongols".<sup>1</sup>

---

1 *This clarification is necessary because otherwise all members of the yellow race (Chinese, Japanese, Tibetans, Burmese, Siamese, Malays, Polynesians, Maoris, Turks, Turkmen, Bulgarians, Magyars, Lappish, Finns, Samoyeds, Kyrgyz, Ostiaks, Eskimos, etc.) would be considered "mongols" and this is not our criterion, as will be*

**Nimrod from  
Rosario**  
*seen.*

**311**

The need to link some "yellow" peoples, often nomadic, with a certain territory in order to consider them, just now, as "Mongols", comes from the particular importance that the Hyperborean Wisdom assigns to a vast region of Central Asia which is often vaguely identified as "Mongolia". Indeed, Mongolia is the CENTER OF LESSER INTENSITY OF THE KALY YUGA, a concept that we will explain later in the paragraph. But now we can advance that it is by virtue of the "geochronological" quality of Mongolia that the peoples coming from its confines always make significant movements for the History of mankind. The Mongolian origin, that is, the fact of coming from Mongolia, is a fundamental sign for understanding the Strategy of the Siddhas:

2ND - THE MISSION OF THE MONGOLS IN HISTORY IS TO "PUSH" THE HYPERBOREAN LINEMEN OF WHITE RACE "TOWARDS THE KALY YUGA".

3º - Without an adequate clarification the statement "2º" will not be understood; because there is a generalized confusion between the western concepts of "History" and "Historical Time" and the ancient oriental concept (?) of "Kaly Yuga". Whoever understands the Kaly Yuga as a simple "historical period", in the Western way, will surely find meaningless the statement that the Mongols must "push" "towards the Kaly Yuga"; but, as we said, this is a product of confusion.

First of all, how much does the period of the Kaly Yuga represent in chronological time? Although there are differences, according to the interpretation of the Hindu sacred texts by one or another school, we can take as acceptable the figure provided by Rama Pra-sad: 438,000 years. Where does this figure come from? From a complex mixed system<sup>1</sup> of division of time that, in the part that interests us, says: "1 solar year of 365 days, 3 hours, 30 minutes and 3 seconds is equal to 1 day and night Daiva; 365 days and nights Daiva is equal to 1 year Daiva; 1200 years Daiva is equal to a Kaly Yuga"<sup>2</sup>. Therefore 1 Kaly Yuga is equal to 438,000 years. As one would expect, the Kaly Yuga begins in the Atlantean epoch, at that time when the Traitor Siddhas are installed at the head of the civilization of Atlantis where they would be known as the "Siddhas of the Tenebrous Face". But that is another story. We know now that a "Kaly Yuga" is an extremely long period of time; but is it only a "period of time"? What does the name "Kaly" attached to "Yuga" mean then (which does mean "Yuga")?

---

1 *That is, a combination of numbers, multiples and submultiples of the decimal and sexagesimal systems, associated with nature's rhythms, such as the solar year, the number of breaths per minute, lunar cycles, etc.*

2 RAMA PRASAD - *The Subtle Forces of Nature* - P. 30 - Ed. Espala, 1923.

What is the term "period of time")? In order to give a clear answer, we will resort to some ancient concepts that are by no means unknown in the West, but which modern historiography has left aside or, if the terms were useful to it, has used them perverting their meaning. This is the case with the word "AGE" from Greek mythology (of gold, silver, bronze and iron), which has been emptied of its primitive conceptual content and used in a profane manner to signify arbitrary parts of official "History": "Ancient Age", "Middle Ages", etc.

4º - Apart from the fact that official "History" covers a ridiculously short period of time, seven or eight thousand years, in relation to the millions of years that the human species has been on Earth, the "ages" into which it is divided are only intended to indicate certain intervals between "important" events for the mnemonic convenience of historians and pedagogues; For example, the Middle Ages "begin in 476, when Odoacer deposed the Emperor Romulus Augustulus, that is, with the fall of the Roman Empire"; and end "when the Turks took Constantinople in 1453"; from that date the "Modern Age" extends. This way of "marking" the limits of the "ages" reminds us of the geographical demarcation of frontiers, which generally exists only in the minds of men and on maps: on the ground, sometimes, there is nothing to indicate that such a country ends here and such another begins beyond, an uncertainty that does not prevent one from blindly believing in "the frontier" as something existing in nature for which it is possible (and desirable) to fight and die. (Let it not be said that a river, for example, constitutes a "real" border; a river is just that: a watercourse, a geographical feature; any cartography attributed to it comes from a gnoseological error, from forgetting that a "geographical border" is a convention between men, just like the symbols of language; and that, because of such symbolic character, it belongs to the collective psyche, that is, to the subjective sphere and not to objective reality as we might slightly believe. Cartography consists in representing graphically signs corresponding to the configuration of the Earth and its accidents; the map, then, possesses a certain relation with the territorial reality, but such relation is UNIVAL, in other words: it is true that that line of the map represents the bank of that river; it is not true, on the other hand, that by painting that line with a determined color to "represent" a border it corresponds to some quality of the considered territorial reality). Like those who believe in the concrete reality of a cartographic frontier, which exists only on maps and in their imagination, there are many people these days who naively accept the division of history into "Ages" and even indulge in value judgments: The Ancient Age was "pagan," the Middle Ages "obscurantist," the Modern Age "brilliant," etc. Evidently we are here in the realm of cultural subjectivism; for neither has History developed on the basis of such "Ages" nor the events that determine the "Ages", nor the events that determine the "Ages", nor the events that determine the "Ages", nor the events that determine the "Ages".

the interval of each "Age" are real historical milestones more important than other events that occurred before or after them. The events that "mark" the beginning or the end of an "Age" are chosen, from among the infinite number of other events that make up History, to form an established pattern prior to the analysis<sup>1</sup>. This supposes that "CRITERION" has been used for the interpretation of History, which explains the subjective character of the conclusions<sup>2</sup>. If the criterion is, as seems to be the case of the official "Ages", to take into account Economy and War as a fundamental parameter, then it is LOGICAL to fix the limits of the interval in wars and battles or in the economic ruin of the Roman Empire. But if the criterion were another, for example: philosophical, aesthetic, technological, etc., surely the "fundamental facts" that mark the limits of the Ages would also be others and even the value judgment of the same would vary notably. For example, the end of the Middle Ages is fixed politically (?) in 1453, when the Turks take Constantinople and the Eastern Roman Empire comes to an end; this is a negative event that has been deliberately chosen to mark, consequently, the end of an "obscurantist Age". But for a positive scientific-technological criterion, the invention of the movable type printing press by Gutenberg in 1450, that is, almost at the same date, would undoubtedly be more important than the fall of Constantinople. It could then happen that the Middle Ages would end on the same date; but by taking a positive event as a limit, the value judgment would have to be modified. Perhaps then the Middle Ages would not be "obscurantist" but "transitional", considering that to arrive at the German invention of the printing press a previous cross-cultural contact with China had to be established in the 14th and 15th centuries.

We have been verifying the subjective character of the modern concept of "Age" and the weakness of those "fundamental facts of History" that are taken as "limits" of the time interval covered; these facts have been chosen based on cultural criteria, often synarchic, and are presented after a previous deformation of the historical truth; thus, a change of criteria leads us to different "fundamental facts", more or less displaced in time, which shows the insufficiency of the concept of "Age" to designate an Era of supposedly specific characteristics.

We must suppose, then, that what official history describes to us in a given "Age" has a distorted relationship with the concrete facts to which it refers, in a manner similar to the subjective alteration of the facts.

---

1 *i.e.: a "hypothesis".*

2 *Criteria" are logical guidelines that inevitably appear in any rationalist consi- deration.*

The real facts are presented by historians as limiting facts.

This assumption can be rigorously verified if we again have recourse to the cartographic analogy and employ the already defined concepts of "the eminent" as "the enhancement of a quality, rationally exalted by the determination of the pre-eminent cultural premises". We look at a map of Europe; on it the different countries, their internal political divisions and their external borders are represented by means of signs known to all. Suddenly we fix our attention on some sinuous lines that inform us that in the corresponding part of the world there must be some mountains; we read an indication that says "Pyrenean Mountains" and we think: "Ah, this is the border between the two countries: -Ah, that's the border between France and Spain-. We know this because this information is a common cultural domain. If we now look carefully among the different lines of the map, an area marked in a different way, perhaps with a different color, or perhaps with lines and dots, will become eminent, which we will distinguish as "the border" itself. The preeminent cultural assumptions made the borderline eminent among many other such lines and led us to discover and recognize it. But, as we have said, the frontier exists only on the map and in our imagination, something that can be verified by placing ourselves in certain deserted areas of the Pyrenees Mountains from where it would be quite impossible for us to decide where Spain ends and France begins.

We have become aware of two pieces of information from the map: in such and such a place in the world, whose location coordinates allow us to identify precisely, there is a mountain and a border. We actually move to that place and find the mountain, but we have difficulty in distinguishing the border. What has happened? Well, mountain and border are realities of a different order. That is why there are two kinds of maps: the "physical" ones, which describe the geographical reality more or less faithfully, and the "political" or "economic" ones, which exhibit, in addition to the corresponding physical representations, qualities and attributes that have no concrete counterpart in the world. A mountain and a frontier are both cultural objects; but the mountain is a concrete object of natural entity, whereas a frontier (like a myth, a scientific idea, a political organization, a moral code, etc.) is a cultural quality that will never appear fully embodied in a concrete, physical or "external" entity.

To do Historiography, to write History, is, analogously to the construction of a map, to DESCRIBE A REALITY. History, in narrating true facts of the past, has at its disposal a purely objective material whose description in symbolic language is presented to us for our information. But the historiographer, like the cartographer, has two types of objects at his disposal: the "facts" that really occurred, which



have been concrete objects, and the "eminent facts", taken from among the infinite other facts for their subjective importance. But the eminent facts, as we already know, are determined by preeminent cultural premises which are, in the last instance, the tactical expression of Culture, the enemy's strategic weapon. Thus, if when studying History we notice that the facts described are presented to us with a certain objectivity, we are, as in the case of the "physical map", before a more or less direct and undeformed representation of reality. But when we try to affirm an eminent quality in a concrete fact, for example, when we say that the French Revolution was "superior to other revolutions because of its progressive character"<sup>1</sup>, we are, as in the case of the "political map", before a representation of cultural qualities without a material counterpart. An eminent quality in History, like a frontier on a political map, is an object that belongs to a sphere different from concrete reality; its eminence comes from preeminent cultural premises. Hannibal or Publius Cornelius Scipio? Sparta or Athens? If History were to present the facts as they occurred, the preference we would declare for such a warlord or such a culture would indicate that that warlord or that culture had become eminent in our eyes. But this is not possible because the history available to us for study is in no way objective or descriptive of the reality of the facts, since historians of all times have been victims of their own pre-eminent cultural premises and have pointed out eminences wherever they appeared to them, attributing to the concrete reality qualities that were only in their imagination; that is, projecting onto the world cultural qualities that had no concrete entity, and then perceiving the mirage of their reflection. That is why the official History is tainted with unreality and should only serve to any researcher of hyperborean lineage as a mere reference, a pale reflection of the truth.

History, after it has gone through the "strategic-synarchical treatment" of the cultural patterns of Judeo-Christianity, is a minefield in which any unwary person can get lost and perish. Its disguised objective is to provoke confusion, the cultural conditioning of "modern man"; that is why it will tell us or induce us to declare that the Athenian civilization was superior to the Spartan one, that the religion of Jesus Christ put an end to the savagery of pagan cults, or other similar hoaxes.

It is now time to refer once again to the "Ages" of official history. See it will become evident, after what has been seen so far, that the modern concept of "Age" is

---

1        *The "superiority" we value of one thing over another is an eminent quality.*

only an arbitrary interval of time, marked at its extremes by certain eminent events for historians who, undoubtedly, are conditioned by pre-eminent premises (which are, in short, synarchical patterns unconsciously assimilated by them). To verify this, it is enough to refer, for example, to the nearest limit of the Middle Ages, noting that the fall of Constantinople has been eminent, for most "historians", over other contemporary events, among which the invention of the printing press stands out, as we have said.

This long critique must have clearly shown us that an "Age" of official history is a cultural object conceived from a subjective view of history, limited by eminent facts that are distortions of the true facts. But such an "Age", as a sum of eminent facts, is an extreme example of a cultural object that bears a distorted relation to the concrete reality of the historical facts it represents. That is why the modern concept of "Age" has almost no content; it is a hollow shell that barely suffices to cover some synarchical lies. It is precisely our immediate task will be to endow the word "Age" with a new content, which in truth is its ancient meaning, for we must use it to define, in Castilian terms, the concept of Kaly Yuga.

5º - Contrary to the modern criterion, the concept that the anti-Goths had of the historical periods did not begin with man but with God. Of course, as long as history was conceived as a cyclical succession of Eras that were born and died like the vital cycles of nature, not one God but a multitude of Gods coexisted, peacefully or not, in the sky of Antiquity. There was indeed a God for every Age, that is to say, one who predominated over the remaining deities and was able to exercise irresistible power over the world and men.

The major period was the "Age" (or the Yuga) which comprised several Eras or human stages of specific characteristics and, naturally, was presided over in all its chronological extension by a superior God whose influence, also cyclical, began and ended together with the Age in question. The duration of an Age corresponded to the manifestation of a God; when the end of such a period came, the God withdrew, but not before sustaining a hard struggle with the successor deity, and his influence ceased thereafter.

Today it is a common opinion that "the Gods die when their Age is over. of predominance", several reasons were given to justify the fall of the deity:

"Men forgot him", or "this God" did not exist at all, he was a myth, and when "progress" or "evolution" led men along the path of civilization, they "woke up" and proceeded to replace their false and superstitious convictions by rationalistic ideas that perfectly explain the development of the Universe without recourse to any divine intervention"; etc. Against this opinion, the Hyperborean Wisdom affirms that an Era concludes when the God (or the Myth) ceases to manifest its influence on the whole of mankind. The Aztec Era ends when the Spaniards replace the bloody cult of the beating hearts with the cross of Jesus Christ; but it is also true that Huitzilopochtli had abandoned the Aztecs long before, as Princess Papan told Moctezuma and as he himself proved, since he was not only emperor but also high priest of the cult of the Hummingbird God.

History informs us that there were Ages in the past during which men adopted particular religious beliefs and cultural styles. Since every Age is governed by a God, one may ask what has become of those deities whose influence was dominant in past Ages? The answer is not difficult, since History also gives us news on such a question: to each past Era corresponds a myth of which Tradition and documents give an account. At one time in Rome Mars reigned and at another Jupiter; Greece knew Eras of Apollo and Zeus; Egypt shone fleetingly under Amon and was feared in the Eras of Osiris and Isis; Carthage became bold in its Age of Moloch; etc.; to give only a few examples taken from recent civilizations. In these examples, and in many others that could be given, it is proved that the previous answer is correct: we know of the God of a bygone Age by the myths and legends that have come down to our days. So much for the answer given by History. We will add the following, and this must be affirmed: the "myths" ARE EFFECTIVELY THE ACTUAL EXPRESSION OF THE ANCIENT DEVALORIZED GODS. Of course, in order to understand this statement in all its depth, it is necessary to resort to the concepts of the Analytical Psychology of C.G. JUNG, which assure that an ancient myth survives as an unconscious containment of the collective psyche. In book 4 this theme is extensively developed and the word "myth" is defined for a "dead" or devalued God, and "Myth" for a dominant or active God. But the important thing now is to keep in mind that according to this theory, Gods do not really die, but rather their disappearance, their invisibility, is due to the fact that they have been incorporated into the collective unconscious of their cultures, losing sight of them momentarily or definitively. In this sense, myth is identified with certain types of collective archetypes, that is to say, common to an entire race, whose characters are inherited and constitute an unconscious content of the human psyche. It should not be believed that this psychological concept implies the invalidation for the God to act outwardly (in a psychoid manner) such as

tradition informs us that all the Gods act. There is a contact between the personal collective unconscious and a "universal collective unconscious" which is the very substance of the Demiurge, the plane where He has deposited the Archetypes of His creation: by an interaction operated directly in the deep unconscious of man is effected the leveling or equalization that makes a myth a "Myth", that is, the process by which a passive structure (the myth) is transformed into a dominant entity (the Myth) fed with energy (libido) subtracted from the psyche. This important issue will also be studied in depth in book 4.

Myths are always present in all peoples and in all circumstances. Their passivity does not mean that they have died, for they could "resurrect" and become Gods again, as in fact has happened many times, according to the convenience of the Demiurge; since the Gods are, as it has already been noted, expressions of their psychoid Archetypes. We will not go into detail on the Plan of the Demiurge and explain the necessity for him to project Manu Archetypes upon humanity in order to direct the evolution of life and form. We will only add that a Manu, the "idea" of a race, is the dominant collective psychoid Archetype, the God, of an Age; but a Manu, it should never be forgotten, is an unfolding of the Demiurge himself, a "divine appearance" devoid of individuality; If he "appears" to be a God, it is because the period of his unfoldment is too long to be appreciable by an incarnated spirit, chained to an incompatibly short vital period; finally, a Manu unfolds in a Hierarchy of intermediary entities, who receive the mission of carrying forward certain parts of the Plan: These entities, together with some members of the devic evolution, and the "evolved" pasu or adepts, make up the White Hierarchy of the Traitor Siddhas.

Using these concepts we can now redefine, in modern terms, the ancient idea of the Age. Let's go from minor to major:

a) Any historical circumstance is the conjunction of humanity and certain Archetypes to which it is subordinated, evolving towards its perfection<sup>1</sup>. Also:

b) A historical Era is the conjunction of a cultural community and of a God to whom it is subordinated and whose Will it obeys. [Or, expressed in modern concepts: a historical Era is the conjunction of a cultural community and a God to whom it is subordinate and whose Will it obeys.

---

<sup>1</sup> *A similar definition has been proposed by André Nataf in "El Milagro Cátaro", Ed. Bruquera.*

Collective archetype to which it is subordinated and towards the realization of which its culture evolves]. Finally:

c) A historical Age is the conjunction of humanity, during such a period, and of a Manu Archetype, to which it is subordinated, evolving towards its perfection. (In this definition the concept of Manu Archetype involves the whole Hierarchy participating in the Plan).

These definitions may provoke a doubt that we will clarify immediately. The question would be the following: if we have rejected the modern concept of "Age" for considering it synarchically conceived from preeminent cultural premises, what sense does it make now to revalue the ancient concept if it expresses that "an Age" is the duration of a Manu Archetype incarnated by the Demiurge? Are we not again on enemy ground? Such objections are well founded and therefore it is worth clarifying that, although both concepts of Age are insufficient and synarchical, the ancient one, although it refers to Manu, will serve us to explain the also ancient concept of "Kaly Yuga"; because, it is worth stating, "Kaly Yuga" is indeed a hyperborean idea, on which mountains of confused opinions have been poured and which we will have to redefine in order to re-veil or approximate its Mystery and make it intelligible to a modern mentality.

The conceptual advantage of definitions "a", "b" and "c" with respect to the dogmas of official historiology lies fundamentally in the fact that such definitions allow us to confront the historical fact considered in its on- logical integrity, while the same fact, described according to official guidelines, is inevitably mutilated in its metaphysical roots. We would like this difference to be clearly noticed before going deeper into the meaning of definitions "a", "b" and "c"; and that is why we will now point out the main reason why the official descriptions of the historical fact are insufficient and partial. We can advance that this cause comes from the confusion between "historical fact" and "natural fact"; but, as such confusion is due to a typical case of gnoseological blindness, to establish the distinction between both concepts will require a long explanation.

Presumably the greatest mistake made by a historian is not to distinguish that a historical event is categorically different from one that occurred, for example, in a remote jungle, with members of the animal kingdom as protagonists, such as a fight scene between two lions. The fight, with all the drama that it may entail for a sensitive observer, is a "natural fact" that has happened with indifference to human existence and that develops under the impulse of a dynamic that is proper to it. The driving force of this dynamic cannot be

The fact that it is exclusive to the natural event, because it is circumscribed to the sphere of its effectiveness, is evident to man. Even intervening in the scene does not achieve more than disturbing the forces and that, in an effort to restore its natural development, the dynamics of the event react against the interference; it may happen that the lions devour the observer and then continue with their combat or that the latter destroys the protagonists with a weapon, or a thousand intermediate variants; but it will never be possible to BE PART of the scene; man will always be alien to the natural event and, therefore, will never be able to get to know it completely.

This insurmountable gnoseological barrier obliges a natural fact to be described from the image that man perceives as a pure observer. From this distance, it is inevitable to deal with appearances or partial aspects of the fact; and for this reason it is, to a certain extent, licit to exhaust methodological efforts leading to the most complete description possible of the natural fact. This is what science does when it sets out to increase the knowledge available about a phenomenon: first it submits it to observation, trying to cover all possible aspects, even decomposing these aspects to arrive at its qualitative constitution and proceed to its DESCRIPTION; if the senses are insufficient, that is, if the phenomenon exceeds the sensory framework, the "technique" will allow the design of instruments that expand the spectral framework of observation and reach the farthest limits of the reality of the phenomenon; Finally, all the information obtained is gathered and interpreted in order to elaborate a theory, which, given the process of disintegration to which the phenomenon was subjected and taking into account that a large part of it must have escaped observation, will always be important to present an integral explanation that will allow us to understand the phenomenon in its totality. Of course, in a civilization where science proceeds in this way, man and phenomenon constitute opposite realities. And even if the former succeeds in obtaining so much knowledge from the latter as to elaborate theories, and even if the latter prove sufficient to develop technologies, the gnoseological gap not only remains open, as it was when the phenomenon was first observed, but threatens to become wider and wider because of the dogmatism with which the aforementioned theories are affirmed without taking into account their errors and deviations. But that is another problem.

Natural phenomena or facts are investigated with the same scientific method and described in theories which, as we have seen, are insufficient to cover their complete reality. For this reason, of a natural fact we can only know some partial aspects, its appearance, and there is no reason to worry too much about it. But different is the case of the historical fact in which man not only participates as a protagonist, but which, fundamentally, constitutes his

concrete support. Here man is not an "outsider"; and for this reason it is not permissible for him to use the same method with which he observes natural facts to contemplate a reality in which he is inserted as an immediate actor. If such a thing is done, and in fact it is "done" in official historiography, it means that a false distance has been taken with the illusion of converting into an "object" under observation a fact of which one is inevitably the subject. But if the theory of a natural fact succeeds more often than not in diverting us from the truth of the fact it tries to explain, the theory of a historical fact, elaborated without heeding these objections, can lead us to the antipodes of its truth. We will be able to verify this last suspicion by deepening now, in this sense, our conclusions exposed in paragraph 4 on the "Ages" of official History.

In the first place, in an official "Age", historical facts are described, highlighted according to the eminence they have had for the historian, presenting them as accidental events whose only determination, if any is suggested, is due to purely physical causes. If one historical fact bears some relation to another, it is asserted that its nexus consists in certain "dynamic variables" (the economy, the class struggle, religion, war, the "dialectical movement," etc.), which are completely external and inconsistent enough to justify by themselves the genesis and evolution of the fact. It ignores here, as in the case of scientific investigations of phenomena, the structural relation that keeps the described aspect with the rest of the elements that integrate the totality of the fact. Official history, by asserting itself on some particular elements of this structure (the variable this or that), can only expose partial aspects of the true facts, apparent images behind which the truth of what happened is hidden. By operating in this way, a historical fact or an Era is presented to us from its most evident side (the appearance), that is to say, its grossest and most material side, affirming as efficacious causes of its determination some of the famous "dynamic variables", which can only be done at the cost of cutting off the metaphysical extensions that every historical fact possesses according to definition "a". Let us look at an example of this rationalist obsession: it was of no value that Alexander the Great himself declared that he began the conquest of the world on the advice of Zeus; for the modern "historian", Alexander, a member of the human SPECIES and of the Greek CIVILIZATION, belonged to the CLASS of the military, to the GENDER of the conquerors and to the GROUP of the believers; Zeus, on the other hand, is only a deity that integrates the SET of the Greek myths. If we reflect on the "scientific" attitude adopted when a historical fact is classified "by parts", we will see that it has been taken as an "object of observation" and therefore confused with a "natural fact", such as an eclipse or the annual migration of swallows, that is to say, with events from whose determinations man is absolutely excluded.

Let us follow the steps taken by the modern "historian". First, an event in the life of Alexander the Great (his decision to conquer the world at the behest of Zeus) is framed in the category of "casus belli, casus dementiae"<sup>1</sup> ; then it is disintegrated by separating its parts, which are classified one by one according to rationalist guidelines, pigeonholing them into sets, classes, groups, etc.; finally, the event is reconstructed on the basis of those parts that the official criterion considers most important or representative (a true theory is elaborated) and presented to the public. Finally, the fact is reconstructed on the basis of those parts that the official criterion considers more important or representative (an authentic theory is elaborated) and it is presented to the public for its consumption. As we announced, it is verified that after the historiographic operation, only a partial aspect of the phenomenon is shown to us; but this aspect is the most miserable, because it describes the fact disconnected from its metaphysical motor, Zeus, who in the 4th century B.C. was a dominant Archetype, a God, and not a mere "myth".

We have demonstrated the inadequacy of modern, rationalistic methods applied to the interpretation of historical fact and we have denounced the error committed by proceeding to disintegrate it analytically and to integrate it by rational synthesis: the investigation of historical fact is approached in the same objective manner with which natural facts are treated.

But the historical fact is not, like natural facts, the objective presence of an evolutionary process whose unfolding man can only attend as an observer. In the historical fact, even in those that have occurred thousands of years ago, man, of whatever epoch, is always a "subject" BECAUSE A HISTORICAL FACT IS, FIRST OF ALL, A CULTURAL FACT. This identity is tre-  
This is extremely important because it underlies the superiority of definitions "a", "b" and "c" over the modern concept of "Age" based on the rational analysis of historical facts. We shall see this as soon as we define what is to be understood by "culture" and "cultural fact".

Let us recall conclusion 7 of the allegory about the "prisoner", the "I" of the virya lost, which we had already seen in the previous chapter.

- 7 -

c - The "prison" is analogous to "culture". Also: certain parts of the "prison", walls, moats, bridges, etc., are analogous to certain parts of the "culture", that is, the "preeminent cultural premises". Comment: keep in mind that, in the

---



1 *Act of war, act of madness.*

allegory, both the "guardians" and the "prison" are intermediaries between the pioneer and the outside world. But the "guardians" are "dynamic" intermediaries (analogous to "reason" in the lost virya) whereas the "prison" is a "static" intermediary (analogous to "culture" in the lost virya).

On the other hand, conclusion 8 stated the following:

- 8 -

c - The "outside world" beyond the prison is analogous to the "outside world" beyond the "cultural structure" that holds the "I" in the lost virya.

From these analogical conclusions the following definition follows: "Culture is an 'intermediary world' between the 'I' and external reality"<sup>1</sup>. But this "world" surrounds the self in such a way that, except for the Vril-center, all paths to external reality must inevitably pass through it; culture truly "imprisons" the self within the boundaries of its environment. Let us go a little deeper into this general definition of culture as an intermediary world.

In the first place, this intermediary world has a clear biological origin; for it is evident that between any external reality and the self there is always the structure of the nervous system (neurophysiological). But culture, like the "prison" of allegory, is a "static-internal structure," whose "elements" are the preeminent cultural premises. Such elements are rigidly linked to each other because they are registered in the memory of the brain and subjected to the neurological mechanisms of interaction. Thus, there is a biunivocal relationship between culture and brain structure or, in other words, between cultural structure and brain structure.

---

<sup>1</sup> *We reject, therefore, the vulgar idea of "Culture" as "the co-lective product of human activity" or other definitions that place the sphere of culture in the "physical world", that is, in the world of "external cultural objects". Here we place Culture in its proper sphere: that of psychic reality.*

There is a biunivocal correspondence between the brain's structure and the brain's structure<sup>2</sup>. Now then: the structure of the brain possesses neurological mechanisms capable of establishing bioelectric "paths" in the complex cellular network; mechanisms that constitute the way the brain functions and that are similar in all human beings. Here there can be no doubt, since the possibility of understanding between men, communication, consists basically in the structural similarity of the brain possessed by all members of the human species; from "communication" derives "culture as a collective fact", which is a second degree of culture, according to the definition we have given of it as an individual "intermediary world".

Before the self exists, there is already the physical body; and when the self is extinguished, there is still the physical body. Therefore: first is the physical body and then the self; or, more precisely: first appears the structure of the brain and then the self<sup>3</sup>. It can be said, then, that, although there is a biunivocal correspondence between the two, the (biological) structure of the brain supports the cultural structure and the latter constitutes the sphere of the self, its environment or "prison". Therefore, the infinity of bioelectrical paths that exist in the brain structure must have their correspondence with an infinity of equivalent paths in the cultural structure, paths from which the self can never depart and which condition it gnoseologically.

The "I" is the present consciousness and as such maintains permanent contact with the cultural structure that surrounds it; but this contact can only be made by following the possible paths determined by the correspondence with the paths of the cellular network of the brain. In the cultural structure, the paths are given on the "elements" of the same. It is worthwhile to ask at once: what things

---

2 We use the word "biunivocal" in a restricted sense: here it means "two-way correspondence" of the structures and in no way implies a mathematical homeomorphism. It is only a didactic example used for the sake of clarity, as is the whole structural model, without prejudice to whether or not such a model can describe the truth of the actual facts. We will only be able to assure that in the (biunivocal) correspondence between a bioelectrical configuration, for example, of the cerebellum, and the cultural structure, an equivalent figure is transferred to the latter, preserving from the former only its "topological invariants".

3 From a metaphysical point of view, the "physical body" is the actuality of an archetypal power that INCLUDES the self insofar as the latter is understood as consciousness referred to the world. But since our commentary requires dealing with facts, we invert the sense of the process to start from the existences given to the observation of the neighbor, of a third party, or of the community: man is, then, pure

**Nimrod from**

**Rosario**

*exteriority; his physical body and his conduct.*

**327**

are the elements of the cultural structure: assertions<sup>1</sup>. Then: "culture also consists of infinite assertions, linked together in such a way that they form a static structure".

It is worth clarifying that "static" is the stable state of the cultural structure, which in no way means that such a state cannot be modified. In fact, the formation of culture throughout life involves the permanent addition of new assertions or the replacement of some by others, but in such cases we are dealing with "states of perturbation", after which the cultural structure returns to its stable, i.e. static, state. The error of believing that there is a "living" or "dynamic culture" comes from not realizing that culture can only be interior, as we consider it here, and from consequently confusing external cultural objects with culture itself. It is worth repeating that external objects, even those produced by man such as a fork or a city, mean nothing outside of him; and that, if humanity were to disappear, all the objects used by man would cease to be cultural. That is why it is ridiculous to speak of "dead" or "living" cultures when referring to the external traces left by human communities in their passage through history (or "prehistory," as intellectuals like to pompously call the time when man possessed purity of blood and did not write). There is only one culture and it is structural, static and interior; and there are external cultural objects, utilitarian or aesthetic, which have a meaning for the man who produces and uses them and which perhaps have another meaning for future men who encounter and observe them. But the totality of all the cultural objects of a human community does not constitute its culture; they neither "live" nor "die"; they accompany it as long as it exists and vary if it evolves or remain stable if the community stagnates or dies. By themselves the objects do not say anything and that is why, when an archaeologist unearths a village of an unknown community, he must allocate part of his own cultural structure to reproduce INTERIORLY the culture of the men who inhabited it. And this reproduction, according to the distance it keeps with his own cultural premises, may or may not modify the structured assertions of his culture. Let us not forget that in the transcultural contact between different peoples, reciprocal modifications occur, such as Greece-Rome, Spain-Mexico, etc. Thus, a quantity of buried cultural objects can never be a "dead culture" if people take care of them. And neither can they be treated as "objects of observation", in the manner of "natural objects", pretending to detach themselves from their human meaning, a meaning that is not only human, but also a "natural object".

---

1 *Earlier we said that the "elements" are preeminent cultural premises, to exemplify; but, strictly speaking, these constitute logical constructions that INCLUDE assertions, that is to say: they are paths that pass through several elements.*

has been restituted in some way from the moment that attention has been fixed on them. For the same reason it is not possible to objectify a historical fact by resorting to the artifice of declaring that it belongs to the past and therefore does not include us as subjects; since the paths that the I travels in the cultural structure to understand the fact make it a current experience that affects and conditions us. It may be that an insufficient understanding of the historical fact changes its original meaning, its truth; this is something that will unfailingly occur, to some extent, due to the influence of the preeminent cultural premises; but the historical fact will always affect us in its character as a "cultural fact", a human fact, and as such it will involve us as subjects of its plot from the very moment we reflect on it. We will return to the double character of "historical" and "cultural" fact.

There is a confusion, then, between cultural objects and culture itself, which leads many to affirm that culture is "dynamic. This confusion is exacerbated when observers pay attention to the movement that people imprint on objects or to the exchange of information that takes place between two interlocutors, which is taken as another type of movement. Against these errors we will say, for the last time, that the variations that cultural objects undergo are indeed an expression of culture, but the external, concrete expression is produced by a human physical body guided by an internal static cultural structure. As far as "cultural exchange" is concerned, the movement is as follows: teacher A says "the dodo is extinct"; the acoustic sentence travels through space and penetrates the sensory sphere of student B, being neurologically transduced as a bioelectrical information affecting the brain functions; the brain functions distribute this information inaugurating a particular path in its cellular structure; this path corresponds biunivocally with another equivalent path in the cultural structure and a preeminent cultural premise is established, which in this case is a simple assertion. There has been here, if the sentence was heard for the first time, a modification of the cultural structure (strictly speaking an expansion); but once the assertion has been structured, the structure itself remains static as long as a new assertion does not appear. Thereafter, when learner B hears the phrase "the dodo is extinct" again, a pure function of the brain, reason, will identify by comparison the old way and a recognition signal will alert the self that the assertion belongs to the cultural structure and reveal to it, to the extent of its interest, the location of and interrelationships with other assertions.

We must now ask: what is the relationship between reason and the self? Let us go in parts<sup>1</sup>. In the previous chapter we defined reason "as an operator that relates different elements according to a certain logic. The 'operator' is hereditary; the logic, that is, the agreed way of operating, is cultural: it depends on social, ethical, moral, religious rules and principles, etc., and is closely linked to one's own linguistic structure, to one's native language".

Let us go a little deeper into this first definition. Earlier we attributed a temporal primacy to the physical body over the self: "before the self exists there is already the physical body, and when the self is extinguished there is still the physical body".

We must now note that the same does not occur with reason; on the contrary, reason accompanies the birth and disappearance of the self. Because of the simultaneous appearance of both subjects, it is common to make the mistake of identifying them with each other, due to the difficulty of distinguishing between them. Thus one speaks of "rational consciousness" or "conscious reason," improperly merging two members of different structures. We have overcome this difficulty by establishing from the outset the distinction between "the I" as present consciousness and "reason" as functional operator, without forgetting the solidarity with which both subjects act.

To understand the relationship between the self and reason in a simple way, we will continue to refer to the model of cultural structure used up to this point, establishing some revealing analogies.

Let us begin by specifying the spheres of reference. By "reason" we mean a higher function of the brain whose operation is characterized by the bioelectrical interrelation of certain elements of its cellular structure; the concrete sphere of reason is, then, the cellular structure of the brain.

In the pasu or lost virya it is normal for thought to be constructed with cultural elements, because the consciousness is oriented towards the external world and all its references come from it. The realm of the I (in the pasu or lost virya, that is, in beings that participate in the evolutionary Plan of the Demiurge), is the cultural structure, which consists of an infinity of assertions. (It is necessary to have

---

<sup>1</sup> *For the sake of brevity we will only deal with this relationship by considering the case of logical thinking, which corresponds to modern man, and we will avoid referring to pre-logical thinking, which is typical of the so-called primitive cultures,*

**Nimrod from  
Rosario**

**331**

*that is, exercised by people purer than us.*



(It should be remembered that the cultural structure does not constitute the WHOLE horizon of the self; and that it is possible to separate, and even completely disconnect, cognitive consciousness from rational determination, as proposed by gnosis).

Normally, then, the self is linked in solidarity with reason, each acting in its own structure. However, a procedural order is fulfilled during the act of rational thinking: from the I to reason and from reason to the I (never the other way around). It is, of course, a mechanism which must be well known before trying to avoid its action, but which is not difficult to explain. First of all, let us say that it is THE MODE that the consciousness assumes in thinking that CALLS reason and motivates my RESPONSE, which always ends up determining the FORM of thought, making any idea reasonable. This happens because REASON RESPONDS TO INTERROGATION. But we are not referring here to a logical question; for logic is the domain of reason and intervenes a posteriori to all reflection; the interrogation to which we allude is simply A MOVEMENT OF CONSCIOUSNESS: that movement effected by the I in order to know, understand or comprehend any ideal object.

In the mental state of pasu or lost virya, reason responds to almost every movement produced in the consciousness; and therefore the intelligence of any order of ideas always tends to be rational.

Seen from this point of view, the process would be the following: when faced with an ideal object, a cognitive movement of the ego is generated; this movement is interpreted as a formal interrogation by reason, which instantaneously establishes a bioelectrical interconnection in the cellular structure of the brain as a solidary response; this particular interconnection, by the biunivocal relation between structures, is transferred to the cultural structure, where it is topologically embodied on its elements (assertions); a logical route is thus formalized which, traveled by the ego, constitutes the very intelligence of the ideal object considered<sup>2</sup>. Of course, such intelligence is completely rational, since it has been constructed in function of the cultural assertions, by its logical relations, and therefore its expression, "the knowledge of the object", will be purely conceptual.

Reason, like a shadow, follows the self in all its movements and attempts to logically formalize their activity; analogously to prison guards,

---

2 *The topological plot enhanced on the assertions, or preexisting cultural*

*premises, of the cultural structure is the "eminence" itself.*

it is an intermediary between the self and the external world. But, according to conclusion 7, reason is "dynamic intermediary", while the cultural structure is "static intermediary". Consciousness, being oriented towards the external world by the mechanics of the rational cognitive process, is situated in an intermediary world which we call "culture", where all objects of knowledge are logically constructed and are a mere rational approximation of the real objects they represent. (The way to free oneself from the yoke of reason does not consist in "avoiding all psychic movement" in order to evade rational response, as contemplative systems propose; but in taking the attention away from the external world and reorienting it towards a new center, from which knowledge is obtained directly from the object, by gnostic revelation. The Hyperborean Wisdom affirms that "interrogation is the worst strategic error of the virya" and recommends using in its place the Gnostic principle: "to know is to remember"; he who interrogates enables reason to confuse him with its deceitful answer; on the other hand, he who disposes the spirit to remember, can come to know everything by immediate revelation since the Truth IS ALREADY IN HIMSELF).

The cultural structure is immersed in the psyche as part of the unconscious strata. Certain "parts" of it emerge into consciousness; they confront the self, as a product of rational activity. These "parts", which notably - and inevitably - modify any idea that is the object of the interrogation, or of the "movement", of the self, are rational constructions elaborated from the "elements" of the cultural structure. And these "elements" are, as we have said, assertions. But such assertions are not codified according to a grammatical language, but their nature is symbolic and constitutes, precisely, the origin of all language.

In a great simplification, we can consider that symbolic assertions can be divided into two groups: an immense number of COMPOUND assertions and a small number of SIMPLE assertions or ARCHETYPES. The simple assertions are archetypal symbols or mathematical principles involved in the composition of many of the compound assertions<sup>1</sup>. And here is something we wanted to point out: during cultural learning, SIMPLE ASSERTIOSES ARE DISCOVERED (because they are inherited), while COMPOUND ASSERTIOSES ARE RATIONALLY CREATED or CONFORMED IN REFERENCE TO EXTERNAL OBJECTS.

---

1 *The hedge principle is, using these definitions, a "simple assertion", i.e., an inherited archetypal symbol or unknown mathematical principle.*

Thus, in potential, the cultural structure is present from the very beginning of the existence of the self; for, from a few simple assertions, reason is capable of reconstructing the whole formidable plot of compound assertions. (The prison-labyrinth that holds the self acquires gigantic proportions, which leave well behind the prison of allegory, considering the infinite assertions in which a Culture can be conformed). However, man rarely suspects the enormous edifice on which his consciousness moves when he travels a path determined by reason as a formula for knowing a thing, a path which, on the other hand, is experienced as the very knowledge of the thing or confused with the thing itself.

Finally, we must emphasize that the cognitive-rational process we have described up to this point prevents the complete apprehension of any natural fact or phenomenon, since the ego will only obtain from it a cultural reconstruction, that is to say, a rational synthesis. In most cases the process develops unconsciously and the ego does not realize that it is dealing with synthetic images, archetypically shaped by the assertions of the cultural structure, which only bear a relative resemblance to the object of reference. But when one tries to "investigate" a natural fact, for example, a phenomenon, then the difficulties become obvious and the rational inadequacy becomes evident. Part of these difficulties have already been considered; now we complete the concept.

Reason "knows" by a dialectical process; its means are: analysis and synthesis, that is: decomposition and reconstruction of the object under observation. For many reasons, which it would be too long to express here, among which are sensory insufficiency and a deficient development of the cultural structure, REASON ACTS WITH GREATER PRECISION IN DECOMPOSITION THAN IN RECOMPOSITION.

SICION. We have already criticized qualitative description and have qualified it as insufficient to apprehend the truth of the concrete object as a totality, that is, its being. Let us now consider the most precise possible description of a phenomenon that can be made by rational means. Theoretically a phenomenon can be described completely, from the physical-mathematical point of view, by establishing a system of differential equations such that each equation contains a principal variable linked algebraically to all the other variables and expresses "the behavior" in time of a principal magnitude as a function of all the other variables.

other magnitudes<sup>1</sup>. But, as we said, it is easier to disintegrate than to integrate: there is no way to integrate all the differential equations that describe a phenomenon and reduce them to ONE FORMULA that allows us to have a complete view of it<sup>2</sup>. The most that is achieved is to order the equations IN AN ALGEBRAIC STRUCTURE! Which is neither more nor less than the ABSTRACT FORM OF THE CULTURAL STRUCTURE of the phenomenon; that is, a cultural structure (or substructure) representative of the phenomenon in which the assertions have been replaced by mathematical variables and the preeminent cultural premises by differential equations. The problem is that no one can contain in his cultural structure a mathematical structure of infinite differential equations; and this system is needed to describe ONLY ONE PHENOMENON! Not even the greatest mathematicians have managed to do anything but intuit, in rare and fleeting ecstasies, the representation of some mathematical structures of less complexity than the one we have considered.

This proves the impotence of any rational method as a way of knowing reality: if it is not possible to apprehend a phenomenon, even when it is transformed into an equivalent mathematical structure, how much less will it be possible to do so when one starts from a few qualities to reconstruct the original object! But, what is worse, the analytical method is often used for more than just investigating phenomena: in fact, as we have denounced in due course, one does not usually distinguish a historical fact from a natural fact; and therefore one pretends to "investigate" the historical fact, rationally, by separating its parts by analysis and then synthesizing "a pia- cere" the past events to present an intentional and often false plot of the real fact. And this attitude is the greatest aberration, we can now understand, since the historical fact is also a cultural fact, i.e., an ESSENTIALLY STRUCTURED external object, against which it is not possible to employ the

---

1 *This example may be disputed, but this does not detract from its didactic merit, which is important here, since we wish to show clearly the inadequacy of the rational cognitive method, and we try to do so briefly. We do not ignore Heisenberg's objection (uncertainty) or others like it, which can nevertheless be overcome by employing discrete mathematics.*

2 *This is what has happened with the mathematical expressions of gravitational and electromagnetic theories and quantum mechanics, which have resisted all attempts to integrate them into unitary formulas.*

tools of synthesis analysis to understand their reality.<sup>3</sup>

Every cultural object is part of the cultural structure and, to a lesser degree, also a structure. The same is not true of natural objects, whose genesis and process escape us, and about which it is often not clear whether their form is supported by a structure or some other kind of organization or whether, perhaps, their matter has no organization at all. In such objects it is possible to apply with some success the rational method, as demonstrated by Western empirical science, and to extract knowledge. But a cultural object is essentially a structure; and as such it does not admit in any case the decomposition of its architecture.

In a structure, each element is interdependent with the other members and with the totality. Therefore, it is not possible, as would be the pretension of rational analysis, to consider the part as separate from the whole; on the contrary, in the structure, the whole conditions the part and determines its function. A cultural object, as a structure, is a totality only apprehensible as such. But such apprehension is perfectly possible, unlike what happens with the physical-thematic structure of a phenomenon, because every cultural object proceeds from the cultural structure, that is, from the human psyche.

Every cultural object is, in this sense, a mathematical project because it has been projected, already structured, in the world from the cultural structure and, like the latter, constructed with simple and compound assertions, that is, with mathematical principles. Thus it is that cultural objects, if they are recognized as such in the world, can be apprehended structurally after their introjection; but if, on the contrary, one tries to decompose them analytically, one will only succeed in dis-trusting the structures and thus definitively ignore their functions.

Now then: a historical fact is, gnoseologically, a cultural fact: the cultural fact "par excellence". (The historical fact can be considered as a

---

3 *Cultural objects" can be "inner" or "outer". The "inner cultural objects" are part of the cultural structure and constitute a first degree in the reality of the object. The "exterior cultural objects" are embodied and materialized projects of the former and represent a second degree in the reality of the object; they are recognized in the world as a reflection of the interior objects, but if this relationship is not realized, the gnoseological error of attributing the cultural qualities directly to the physical body that represents the cultural object can be committed.*

past" cultural fact). Protagonized by the members of a community, it invokes in its plot not only the universe of external cultural objects but also the neighbor. The historical fact, in its character of cultural fact, is therefore essentially structural.

We have already said that the analytical method is insufficient to provide certain knowledge of an external cultural object due to its condition of structure and that it must be apprehended directly in the cultural structure, which is interior: it belongs to the psychic sphere. This means that, although the apprehension is made with reference to the cultural object itself, the cultural structure provides the consciousness with an image conformed independently of the exteriority of the object. An object thus apprehended is essentially structural, because it is cultural, and in no way has it been divided by reason. Does the same thing happen with a structure that is composed of a collection of external cultural objects, the historical fact, for example, as a cultural fact?

First of all, let us see what kind of structure the cultural fact is by establishing, for this purpose, a relation of analogy with the cultural structure. Let us begin by de-naming the structure of the cultural fact SUPERSTRUCTURE and let us consider that the "elements" members of it consist of external cultural objects. The neighbor, in it, is effectively structured as an external cultural object. The superstructure thus becomes purely factual and composed of cultural objects that play a role equivalent to that of the assertions of the cultural structure.

But between the cultural structure and the superstructure of the cultural fact there is no opposition but integration. Indeed, there are two reasons for this: on the one hand, the superstructure surpasses man's cognitive capacity insofar as it includes him as a member of its context; and on the other hand, it possesses sufficient power to grasp the cultural structure of any individual and integrate it into his own existence. In other words: man, if he is an unconscious protagonist, acts as an external object participating in the unfolding of the cultural fact; but as soon as he tries to know, and directs his attention not to the structure of the external cultural objects but to the superstructure of the fact, then the cultural structure is confronted with the superstructure and the greater power of the latter catches the former, also externalizing it and converting it into an active subject of its drama.

It is impossible, then, to know the true form of a superstructure; and not precisely because of the limitations of rational inquiry. But "the form" that supports a superstructure is "the cultural fact" itself, to which, and this

We affirm it again, it will not be possible to apprehend AS AN OBJECT OF KNOWLEDGE.

It is not possible to apprehend the cultural fact before being apprehended by it; it is not possible to take it as an object before it includes us as subjects of its drama. That is why it makes no sense to distinguish cultural facts "temporally" by the degree of power they possess to act upon us and to suppose that past, i.e. historical, facts are passive and, therefore, susceptible of being taken as objects of study or "investigation". Every historical fact is actual for those who fix their attention on it, that is, for those who confront their cultural structure with the superstructure of the fact.

We have said that the superstructure of the historical fact possesses greater power than the cultural structure of the observer and that for this reason the former is always actual for the latter, trapping him as the subject of the drama. One may ask then, from where does this tremendous power, capable of integrating man in his own process, come to an external organization, "from the world": FROM THE PSYCHOID COLLECTIVE ARCHETYPES. Answer that refers us to definitions "a", "b" and "c", to which we will expand after considering the comments made so far.

In paragraph 4 we demonstrate the arbitrary way in which modern Historiography uses the word "Age", which has been emptied of its content in order to serve only to indicate the intervals of time into which official History is divided. In paragraph 5 we declare our intention to restore to "Age" its ancient meaning and, to this end, we adopt a critical attitude towards the "rationalist mentality", guilty of most of the errors that are committed when we try to know the truth of a historical fact. We begin by recalling that in remote antiquity the concept of Age did not start from man but from God. But then we clarify that the ancient "Gods", today remembered as myths, are in reality external Archetypes (psychoids), that is to say, dominant in certain epochs to act ON MEN AND THEIR ENVIRONMENT. Then we postulated three definitions (a, b and c) of which the first one said: "any historical circumstance is the conjunction of humanity and certain Archetypes to which it is subordinated, evolving towards its concreteness".

In order to understand these definitions in all their depth, we decided to show that "historical fact" is usually confused with "natural fact", to which man is alien: it is not possible, we said, to take "historical fact" as a mere "natural fact" and make it the "object" of research. Why? Because the



Historical fact includes man in its form as a concrete support and not only prevents it from being "alien" (as with respect to the natural fact) but also manifests itself "always present" for his attention, independently of the chronological time in which such fact has occurred.

We said then that the key to this behavior was that the historical fact was (or had been) a "natural fact" and we defined culture as an "intermediary world between the self and the external world". But culture is an "inner" world, proper to the psychic sphere, and its nature is structural, so we called it "cultural structure". We stated that the "elements" of the cultural structure consisted of assertions and established that between it and the cellular structure of the brain there was a biunivocal relationship: the bioelectrical configurations of the cellular structure transfer their topological equivalents to the cultural structure. To form these bioelectrical configurations there is a function of the brain called "reason", which "responds" to any "movement" of the self and intercepts it as "interrogation".

The cultural structure is immersed in the personal unconscious, except for those constructions (of assertions) that emerge to the self as "racial response", which is the crudest form of knowledge.

Finally we return to the identity "historical fact-cultural fact", but now we see that the cultural fact is ESSENTIALLY STRUCTURED, and so is the historical fact. But the cultural fact is factual and includes in its structure the external cultural objects and the men who manage to integrate its power; it is, quite rightly, a "superstructure". That is why we asked: where does the power it possesses come from, to an "external" superstructure, proper to the "world"? And we got the answer: from the collective psychic Archetypes. Let us now extend this answer by resorting to the analogical comparison between the cultural structure and the superstructure.

Let us consider, for the moment, the cultural structure. Its sphere is the psychic sphere in which, as we have said, it is immersed at the unconscious level. Some of its fundamental elements, the simple premises, consist of typical archetypal symbols with which the ideas or representations to which the ego refers are often shaped. Let us suppose that a certain movement of the I, through a reflection that is not relevant, provokes as a "response" that a triangular image emerges in the consciousness. First of all, it must be ruled out that such a triangle is the archetype itself, since by an act of will we can duplicate or even multiply the image, which proves its reflex character. The triangular archetype,

Like any mathematical symbol or simple assertion, it always remains in the cultural structure which it cannot leave, due to the links it maintains with the remaining members of the same. The emergence (or "eminence") of the archetypal image before the consciousness operates from the cultural structure at the request of reason (in the structure of the brain). If the triangle archetype remains in its structure, it nevertheless possesses sufficient power to actualize an image in the conscious sphere; but this emerging image has the power to effectively capture the attention of the self.

In summary: an unconscious archetype, if it possesses sufficient power, is capable of actualizing itself at the conscious level and establishing a referential relationship with the self, determining the content of the consciousness. This is the ideal case for the action of a single archetype, since combinations of simple assertions are more probable, that is, the intervention of compound assertions.

Let us suppose the case in which the rational "answer" produces a movement in the image of the triangle archetype, for example, a rotation. Here, in addition to the triangle, an archetype "arc of circumference" intervenes, since the combination of both will give the image of the triangle rotating, the arc being the representation of the trajectory followed by the triangle in its movement. What does the "I" do to all this? As its attention has been trapped in the emergence of the triangle, the consciousness persists during the whole movement, until the extinction of the image. An important conclusion must be drawn from this: from the emergence of the archetypal image until its extinction, it underwent a series of referential modifications, for the I, that constitute a PROCESS. Well, let us express these considerations in a general way: "the emergence of archetypal images in the consciousness tends to alienate the attention of the I during its entire process".

This process can only be interrupted by an act of will that allows the self to subtract itself from its reference to the emerging images. But the will is simply a quantity of energy available to the consciousness for its utilization; if this energy ACHIEVES, then the attention will be drawn away from the image; but if it is insufficient, the image will continue to alienate the attention of the self and will remain evolving at the conscious level. When the I is thus linked to an archetypal image, this means that it has been momentarily incorporated into the cultural structure, of which it will form part during the process, since the energy necessary for such a process to continue is provided by the consciousness itself, albeit involuntarily.

We will explain it step by step. The archetypes possess an energy of their own that allows them to maintain themselves in the cultural structure, but which is insufficient to enable their emergence at the conscious level; for this to be possible, additional energy is needed. Where does the energy with which the archetype increases its potency and crosses the threshold of consciousness come from: from the bending of the self. A bending of the self in a certain sense can vitalize an archetype sufficiently for it to actualize its image, which will tend to unfold in an attempt to concretize itself and will take, for this purpose, more energy from the consciousness<sup>1</sup>. A very powerful archetype can empty the consciousness of all content and force it to carry out its process, so that the "I" becomes an expression of the archetype itself. This absorption of the consciousness by the unconscious archetypes and the consequent subjection of the I to a process of unfolding does not necessarily imply the loss of the individual sense, but rather the almost absolute weakening of the will, which is powerless to tear the I from its formal limits.

To sum up: the emergence of an archetypal image (or any other manifestation with which the archetype actualizes its presence) will be objective, and as such susceptible of knowledge, to the extent that the I retains its volitional energy; but if the I is attracted to the image, whether it merges or identifies with it, and participates in its process, then there is no longer any subject-object differentiation and the I becomes integrated as ACTIVE SUBJECT of an unfolding originating in the cultural structure and, therefore, essentially structured. Chained to the process, to a process that is nourished by its own energy, the I can only wait for the concretion of the unfolding: the entelechy of the archetype. Finally, it is worth repeating that the archetypes, being elements of the cultural structure, basic matrices of the mind, will always be unconscious and unrepresentable and can only be known through their manifestations.

Before explaining the analogies presented by certain aspects of the cultural structure and the superstructure, it is necessary to make two clarifications.

The first is that, as has already been explained at length, we deny any value to external cultural objects as "expressions of a culture"; and we value instead the "cultural fact" in which, together with cultural objects, the human presence plays a part. We know the "cultural fact" to be structured; sustained, sustained, sustained, sustained.

---

1 *We speak of "image" because we continue to refer to the example of the Ar-type-triangle, which is purely formal; but it could also be another type, such as a pattern of behavior or "instinct", which would induce the ego to adopt a certain*

*attitude.*

The perception of the superstructure of the cultural fact (a purely external reality) is what is commonly called "culture". It is, then, the perception of the superstructure of the cultural fact (a purely external reality) that is vulgarly called "culture". Against this gnoseological error we declare that "Culture is an intermediary world between the self and the external world". Culture, thus understood, consists of a static "cultural structure" of psychic nature and a dynamic operator, "reason", a function of the cellular structure of the brain.

The second clarification refers to the term "PSYCHOIDEO" that Dr. C.G. Jung has used to designate the absolutely transcendent character to the consciousness of the collective Archetypes; their irrepresentability. Here we give this term a restricted meaning, which should be defined in order to avoid confusion: "Psychoid" are the Archetypes of the superstructures, which are "external", different from the "internal" cultural structures, whose Archetypes are of a "psychic" nature.

We must now speak about the collective psychoid Archetypes. First of all, let us say that in the same way that the Archetypes of the cultural structure are "unrepresentable", the "psychoid" Archetypes are "ungraspable" by the cultural structure and "irreducible" by reason. It is impossible, then, to "take cognizance" of a psychoid Archetype through the "cultural way".

The psychoid archetypes are the product of the Will and Imagination of the Demiurge; but here it is necessary to take into account some concepts of the Hyperborean Wisdom.

1º - Although there are countless psychoid Archetypes, they are all composed of combinations of a single element: the archetypal monad.

2º - Monads are "first" emanations of the Demiurge.

3º - They possess sufficient power to actualize themselves on the physical plane or, better said, the "physical plane" or "three-dimensional space" is the "actual" expression of the monads. To a monad corresponds an "archetypal quantum of energy" E.U.

V.A.C. on the physical plane.

4º - The first manifestation of the Demiurge is the emanation of the monads; the second is the Word or Logos, which "orders" the monads into psychoid Archetypes.

**Rosario**

5º - The psychoid Archetypes manifest themselves on the physical plane in a  
"for-

The "evil" is due to the fact that the monads with which they were "ordered", i.e., conformed by the Logos, also manifest themselves, punctually, with units of uevac energy. On the physical plane, the set of uevac units corresponding to the monads of the psychoid Archetype formally "describes" the Archetype. But even if this physical form contains the most diverse varieties of substance, the transcendent support of its material structure is always the psychoid Archetype.

6<sup>o</sup> - The psychoid archetypes that interest us most, those that are actualized in terrestrial forms, have their seat in the "psychosphere": "a great field that surrounds the Earth and totally permeates it", as defined in book 4.

Although all physical bodies or natural objects and, in general, "all forms" are sustained by psychoid archetypes, we will henceforth reserve this denomination for those "forms" that are the object of this commentary: the "cultural facts. And here it is not a matter of a whim, since the cultural fact is also for the Demiurge the most important object of all his "creation". But this statement deserves to be clarified.

We have already said that the Hyperborean spirit was chained to matter by a Mystery of Love, and that the Traitor Siddhas contributed to this. We will now expose a fundamental concept of the Hyperborean Wisdom that explains the reason why the Demiurge is INTERESTED in chaining the spirits. This reason has nothing to do with "Good and Evil" or any other dualistic justification: remember that at the "coming" of the Hyperborean spirits to the Solar System, it had already been built by the devic Hierarchy following the "direction" of the Logos and, therefore, all the pairs of opposites were already manifested.

The concept is the following: The Demiurge NEEDS the hyperborean spirits en-chained to FORM the cultural superstructures, since WITHOUT THEM THE CULTURAL EVENTS WOULD NOT TAKE PLACE. (Surprising, isn't it?). It is worth mentioning.

The Demiurge "thought" of man as the culmination of his creation, as his Hebrew worshippers relate in Genesis. Naturally, "man" created by Jehovah-Satan was an Archetype that required, for its physical concretion, an evolution of life and form. After certain periods of time, the unfolding of the "human monad" and "man", faithful to his Archetype, should be completed,

He was to become the king of creation. But this absurd Plan failed and, after millions of years of waiting, the Demiurge had to convince himself that his "hominids" did not acquire a single spark of individual consciousness. And without this consciousness, the unfolding of the collective Archetypes that he had so carefully prepared for the "pasu communities" to progress into cultural forms would not be feasible.

The failure was so resounding that, when the hyperborean spirits entered the Solar System, they found that the pasu of the Earth, after hundreds of millions of years of "evolution", had never managed to get out of animal savagery. The "solution" was offered to the Demiurge by the Traitor Siddhas: a genetic alteration of the human species and the incorporation of hyperborean ancestors into their heritage would make of the Pashu "true men", producers of "culture" ... All the civilizations of the Earth are subsequent to that infamous betrayal, known as the Mystery of Love ...

Since then, the pasu and the lost virya produce "cultural facts", super-structured by psychoid Archetypes, which also explains the definition "a": "the historical circumstance is the conjunction of humanity and certain Archetypes to which it is subordinated, evolving towards its concreteness".

Let us now complete the promised analogies.

1st - Let us recall the following conclusion: "the emergence of archetypal images in the consciousness tends to alienate the attention of the "I" during its entire process". In the "external world" the emergence of a psychoid archetype is called a "cultural fact". The cultural fact is the form that contains a superstructure of cultural objects, as already defined.

The Archetype of the psychic sphere (simple assertion) possesses an energy of its own; but, in order to emerge, it needs additional energy, which is contributed by the flexings of the self. The psychoid Archetype of the psychosphere also possesses an energy of its own; but, in order to emerge, it needs additional energy, which is contributed FROM THE UNIVERSAL COLLECTIVE UNCONSCIOUSNESS. (The "universal collective unconscious", in which the "personal collective unconscious" participates, is a concept that will be correctly defined in book 4, where a technique of Psychosocial Strategy based on the properties of the psychoid collective Archetypes is studied. For the time being the following is valid: the universal collective unconscious is part of the psychosphere).



When a psychoid archetype is actualized in a superstructure, the latter does not remain still, but, on the contrary, shows itself to be animated in a certain way. The form, that is, the cultural fact, evolves toward its maximum perfection, which is also the closest possible approach to the "archetypal form"; that is why we call "entelechy" the "final form" which is the Archetype itself, toward which the evolution of the fact tends. But the form is sustained by the superstructure, so that it is in it, in each of its elements: cultural objects and human community, that the psychoid Archetype develops and becomes concrete.

In this evolution the Archetype brings into play an enormous amount of energy, which constitutes the very "reserve" of the community (energy taken from the "collective soul") and which is transformed and channeled into the superstructure.

It is now understood why we affirmed that the "greater power" of the superstructure was capable of grasping the cultural structure of an observer and integrating it into his own existence. The greater power comes from the fact that the energy that drives the development of the cultural fact is of a higher degree than human, that is, than that of the individual man, since its origin is collective. The cultural fact evolves towards its entelechy, but progressing instant by instant in different concrete realities. If a man "does not participate" in the cultural fact, an impossible hypothesis as we shall see, he confronts its reality by taking it as an object of knowledge, he will try to reduce it rationally to concrete reality by abstracting certain eminent qualities. We have already explained that it is not possible to apprehend a superstructure, nor any structure, by employing the analytical-rational method, going from the concrete to the abstract. But the problem here is not that man, the objective "observer" of the superstructure, obtains an erroneous concept of it; but that by this very act of observing he becomes one more element of the superstructure, through which the evolutionary impulse of the psychoid Archetype is channeled.

The cultural fact is developing driven by a great power, WHETHER THE OBSERVER NOTES IT OR NOT; and in this march towards entelechy the superstructure TAKES WHAT IS NECESSARY FOR ITS PERFECTION AND REJECTS THAT WHICH IS UNNECESSARY TO IT.

USEFUL OR OPPOSITE. Except in the case of the awakened virya, who will be rejected by his opposition, all men ARE NECESSARY for the evolution of the fact insofar as they participate in it. But to be an "observer" is already to participate, as a witness; and therefore all the power of the superstructure will be concentrated to achieve its integration. This is not difficult because when "observing" (the cultural fact) the "cultural structure" of the observer and the superstructure are confronted, producing what the Psychosocial Strategy calls

"CAPTURE", that is, integration into the evolutionary process of the cultural fact.

Naturally, one or several men participate unconsciously in a cultural event, who are ultimately the ones from whom the psychoid archetype nourishes itself in order to develop; we did not want to touch this aspect of the superstructure because it is studied in the Psychosocial Strategy within the theory of "gregarious phenomena" (book 4) and because the case of the "observer" captured by the superstructure is highly didactic to clarify what we have been explaining about the fallacy of considering "cultures" as an "object of knowledge".

How is capture produced then? Because when the observer's "reason" explores the superstructure, he discovers in it his own projections; that is to say, he "sees" in the external world things of his inner (unconscious) world. But these projections do not occur accidentally, but ARE SEARCHED for by the psychoid Archetype by adequately disposing the superstructure to receive the convenient images. If the observer believes that he sees the cultural fact developing according to his own inner processes, he will voluntarily integrate himself into the external process, or, in other words, he will weaken his will to oppose. We ask ourselves how is it possible for the observer to see that which suits the evolution of the psychoid archetype and not something else? And we will try to explain it by means of a metaphorical figure. Let us imagine a mosaic in which the images of all the people we have known in our life are arranged, one next to the other, in no order. It would undoubtedly be an enormous picture, let us suppose it to be about a thousand square meters. Let us imagine, again, that such an enormous mosaic is standing vertically behind us and that we cannot turn around to see it. The only recourse we have is to use a small mirror, which will return a portion of the mosaic to us, because it is too large and we are too close to it. Well, things being thus arranged, it will be enough for us to MODIFY THE POSITION OF THE MIRROR to obtain the reflection of each one of the faces of the mosaic. But among the many people represented there, there are some that we love, others that we hate, others that hate or love us, those that arouse pity or resentment, etc.; that is to say, the people we have known in our life are not only memories, but, associated with their image, there is an affective charge that is made evident by the evocation. That is why when we move the mirror we see a face that makes us smile and then another one that we do not want to remember, and a third one for which we shed a tear, and then, perhaps, we return to the one that made us happy and we stop for a long time on it, or, if we have not found it yet, we will move the mirror and go through the mosaic SEEKING the most beloved face.

Inside us there are always things we want to see, feel or do, and others that we try to deny or hide. To catch ourselves, we only need to face the reflection of our own desires. The psychoid archetypes "orient" our own desires.



cultural objects" and "man" (lost virya). Wherever a "cultural object" is recognized, it will always be a plane of action for the psychoid archetype, which will incorporate the observer as an actor in its drama; forming a "superstructure" and forming a "cultural fact".

We see, then, that for the process of a psychoid archetype there is no need for time: only cultural objects and culturizing subjects are required, that is, men provided with a "cultural structure" for whom the objects mentioned are identifiable. Hence, past facts can be re-interpreted, becoming "current", from the very moment that a "cultural relation" is established with an observer, that is, with someone who is under the illusion that a cultural fact can be the object of his observation. A historical fact, that is, a past cultural fact, will always be potent to incorporate a man as the subject of a drama. This being so, where does the necessary power for this come from?

We have said that, in a superstructure, capable of "capturing" a man and incorporating him into its process, the potency comes from the psychoid archetype toward which it evolves. But a superstructure is factual, concrete at every moment of its development; the power that gives actuality to the cultural fact is clearly seen in the dramatic change that manifests itself in the neighbor, unconscious actor (like ourselves) of a transcendent and ungraspable argument. This prodigious power, which develops in an irresistible way as "force of destiny" or "direction of the drama of life", is acceptable that it comes from a psychoid archetype "dominant" in the present moment since "we can verify it in the dynamics of the cultural fact", of "this" cultural fact in which we are included as active subjects. But, from a past fact, it is not very evident how there can be enough power in a "devalued" psychoid archetype, transformed into a "myth", to capture an observer and incorporate him into its drama. However, this is an illusion produced by the excessive dependence on the temporality of the external world, by the synchronization of the biological clocks of the microcosm with the time of the macrocosm, which translates into an artificial exaltation of the "present" as the temporal support of the consciousness; hence the "I" is always "present consciousness. In reality, a psychoid archetype that was dominant in the past, and whose process gave rise to a historical fact, has not vanished into nothingness just because it has reached entelechy ONCE in History; to think that would be like supposing that that corn plant, whose germination and growth we have observed, could not repeat itself again after the evolutionary process has been exhausted. But we know that this is not so and that, in nature, life repeats itself following the cycle of the formative process. In this sense, the Ar-

that psychoid types of a superstructure do not differ from those that sustain natural forms; and both of them are CYCLICALLY trying to manifest their process and evolve towards the concretion of entelechy.

A psychoid archetype never dies. If it "disappears" from sight (i.e., from the collective consciousness), this can be due to two causes: either it continues to act effectively, but at an unconscious level, or it has really lost its effectiveness to act; the latter means that it will remain in the psychosphere until such time as a human community vitalizes it and incorporates it into its process. But a "sleeping" psychoid Archetype, a myth, is a germ that seeks to develop at all times; and that is why it is not possible to contemplate the historical fact, to "study it and know it" objectively, for it immediately incorporates us as subjects of its drama. Of course, this capture does not mean that the historical fact will be repeated in the SAME way as at the moment when it occurred; for that it would be necessary that nothing had changed, for example, that all the cultural objects and the same climax of that fact that we are evoking were there. This is not how a psychoid archetype manifests itself. In the same way that no kernel of corn is the same as the other, but that does not mean that they are no corn, the forms that the facts produced by the same Archetype acquire in different historical epochs admit a certain degree of variation, neither essential nor structural. The cognitive relation established with the psychoid Archetype of a historical fact, even if it is not sufficient for it to develop completely, IS SUFFICIENT, nevertheless, for it to DEVELOP TO SOME EXTENT. And that development, that power that begins to flow in us when we "understand" the dramatic plot of the historical fact, implies the capture and inclusion in a superstructure, in the same way as if we had observed an apparently "more current" or "present" cultural fact.

7 - We can now return to definitions "a", "b" and "c". Applying the concepts we have seen so far, we can better understand what we meant by: ("a"): "any historical circumstance is the conjunction of humanity and certain Archetypes (or myths) to which it is subordinated, evolving towards its perfection". We could also add: "The historical fact is the concrete form that a superstructure of men and cultural objects acquires during its evolution towards the entelequia of the psychoid Archetype". A Historical Age is thus, not a simple period of time between eminent events, as official History would have it, but "the evolutionary process of the Manu Archetype". This psychoid Archetype, which acts on all humanity, takes thousands of years to develop and is the true "force of History", the ultimate dynamic of every cultural fact. Under its enormous mantle are sheltered other lesser orders of collective Archetypes. Such Archetypes can manifest themselves in diverse facts, but ALL THE FACTS keep among themselves a re-

The macro-structure (of all cultural facts) is a concrete form of the Manu Archetype.

So potent is this Archetype that the beginning and end of its process is accompanied by tremendous modifications in the earth's surface and an "evolutionary leap" in the humanities that populate it. This means that there is a telluric influence of the psychoid archetypes in relation to human evolution. In the following paragraphs this relationship will be explained; since without the concept of "microclimate" and "psychoid island" it will not be possible to understand the GEOCRONIC effect that the Earth exerts on the different ethnic groups and the reason for the ancient strategic migrations. When we presented the story of Nimrod, the Defeated One, we made a brief allusion to the fact that the Demons of Chang Shambala fulfilled "absurd roles of Manu". This statement refers exclusively to the method employed by the Traitor Siddhas to genetically "adjust" the different races: for this purpose, they precipitate the entelechy of a human Archetype and, incarnating themselves momentarily in that TYPO body, they give themselves over to copulating with members of the race they intend to "evolve", a task for which they have always shown a special predilection.

We cannot develop here an outline of the planetary and solar Hierarchy because of the length of the text that this would demand of us, and because our objective is to expound the Hyperborean Wisdom, that is, the Gnostic science that teaches the captive spirit the way to free himself from material chains, and not to waste time commenting on the infamous work of the Demiurge. But it is worth remembering that the Earth is part of an "evolutionary chain" as are the other planets of the solar system, being all included in a Plan of Evolution (Colossal Archetype) conceived by the Solar Demiurge or Solar Logos. However, in these dissertations, when we refer to the Demiurge we generally do so thinking of the Planetary Logos or Sanat Kumara. The Manus depend on him: the "seed Manu" which is the "idea" of the Earth with its seven kingdoms, which he drives evolutionarily in its development. Then there is the root Manu, which is the Archetype of a humanity, including its races and sub-races. There are also Manu Archetypes of a "root race", etc.

As we have said many times before, the demons of the Hierarchy claim that "evolution" according to the Plan produces undeniable progress in the "incarnated egos. The fulfillment of the archetypal patterns is a true entelechy and, therefore, every man who has passed a certain number of incarnations, subject to the Karmic laws, must transcend the human level and pass to the "super-human" or adept, that is to say, to become part of the Hierarchy. As we expressed it a few pages ago, referring to the synarchic conspiracy that aims at valorizing

In the future are the entelechies of all Archetypes and, consequently, human perfection "by evolution" towards a Manu Archetype.

However, against this idea, from remote times, the concept was opposed that, as the Ages passed, man involuted and fell more and more into the mire of matter. For those who held this view, life was a "drama" and the future a "catastrophe".

It is easy to see that this concept comes from the Hyperborean Wisdom and that it is not simply an "idea contrary" to the Plan of Evolution, but the product of perceiving gnostically, with the blood, the tragedy of the spirits chained to the evolution of the psychoid archetypes. Such perception corresponds to an intuition of the divine origin of the spirit and to the certainty that every subsequent time represents a decadence: the loss of a state of primordial divinity.

This concept of spiritual "fall" and "loss" of divinity is clearly hyperborean and very ancient. But over the millennia, this concept became exoteric and gave rise to various mythological figures in which the ancient perception of the primordial origin is nevertheless clearly recognized. The main of these figures is that of the "Golden Age", where the "immortal spirit" has been humanized and imagined as inhabiting a Paradise or Eden. But even so, as exoteric as this image is, it is the ancient hyperborean concept and should be recognized as such. Subsequent degradations conceived four "Eda- des", each more decadent than the last, as can be read in the early Greek classics (Homer, Hesiod, etc.). The Roman poet Ovid, who lived in a late period (43 B.C. - 17 A.D.), picked up from the Greek tradition the following:

#### *IV - THE FOUR AGES*

*"The first of all was the GOLDEN AGE, which, without coercion, without law, practiced faith and justice by itself. Punishment and fear were ignored, and no threatening words were engraved in public, in bronze, to be read, and the suppliant debt did not tremble in the presence of its judge, but was safe without defender. The pine had not yet been cut down in its mountains and had not yet descended to the liquid plain to visit a foreign world, and mortals had not yet known other shores than those of their own country. The cities were not yet encircled by deep moats; there were no long trumpets, no bent bronze horns, no helmets, no swords; with no need of soldiers, the nations passed safely through their idleness.*



*pleasant. The earth itself, free from all burdens, neither cleft by the hoe nor wounded by the plough, gave of itself everything; and content with the food it produced without any compulsion, men gathered the arbutus, wild strawberries, fruits of the dogwood, blackberries that clung to the thorny brambles, and acorns that had fallen from the copious tree of Jupiter. Spring was eternal and the gentle Zephyrs caressed with their warm breaths the flowers born without seed. Also the earth, which had not been tilled, produced crops and the uncultivated field was covered with fruitful ears; rivers of milk and rivers of nectar flowed and from the green oak the golden honey was distilled".*

*"After the world was under the rule of Jupiter, once Saturn was not sent to the tenebrous Tartarus, came the SILVER AGE, inferior to the Golden, but better than that of the yellowish bronze. Jupiter shortened the time of the ancient spring and, by means of winter, summer, fickle autumn and shortened spring, divided the year into four seasons. Then, for the first time, he scorched the air impregnated with fire and the ice, hardened by the winds, was in suspense. Then, for the first time, men entered their houses; those houses were grottoes of thick foliage and branches intertwined with bark. It was also then that the seeds of Ceres were driven into the long furrows and the oxen groaned under the weight of the yoke."*

*"After this came the third, the BRONZE AGE, fiercer in its natural conditions and more ready for terrible combats, not being, however, perverse."*

*"The last was that which had the hardness of iron; in this age of so vile a metal, all kinds of crimes appeared; modesty, truth and good faith fled and fraud, perfidy, treachery, violence and the unbridled passion for riches took their place. The sailor gave his sails to the winds he did not yet sufficiently know, and the timbers of the ships, which for a long time had been on the heights of the mountains, were thrown into the unknown waters, and the surveying song pointed out long limits to the land, once common, like the light of the sun and the air. And not only did they demand from the fecund earth the crops and food due, but they penetrated into her bowels and plucked out treasures that excited all the evils, which she had buried and had hidden in the shadow of the Styx. And already had appeared the harmful iron and gold, much more harmful than iron; war appears, which fights with each of the two, and with its bloody hand waves the resounding weapons. One lives by rapine; the host is not sure of the guest, nor the father-in-law of his son-in-law; concord between brothers is also rare. The husband plots the wife's doom and the wife her husband's; the terrible stepmothers mix the envious ven-*

*The son, before the time, is informed of the father's age. Lies on the ground the vanquished piety and the maiden Astrea, the last of the immortals, leaves the earth drenched in blood."*

In this story of Ovid, and in others like it, people have tried to see the memory of human prehistory and the confirmation of the glaciations, which is not entirely wrong. But, under the mantle of myths and legends, the aforementioned concept can be clearly seen: at first a Golden Age, which is a degraded idea of the "origin", and then three "Ages", Silver, Bronze and Iron, in which man increasingly accentuates his spiritual decadence. And this concept, underlying the shell of the myth, is clearly hyperborean, as we have said.

In India, so culturally chastened by the "Masters of Wisdom" of Chang Shambhala, a solution to the obvious fall of humanity into materialism has been given by the incorporation of the four Ages in their eternal cycles of return. The "Ages" are SATYA YUGA (Golden Age), TRETA YUGA (Silver), DVAPARA YUGA (Bronze) and KALY YUGA (Iron); of course, these four "YU- GAS" or "AGES" form a CHATUR YUGA, which returns to repeat itself eternally in the different manvantaras, or periods of manifestation of the Demiurge. The "fall" is here justified to facilitate new "Karmic ascents" within the sinister Plan of Evolution, which has its concrete expression in the Manus or psychoid Archetypes. But this is only a cultural maneuver of the Masters of Chang Shambala, who have sown confusion in the hyperborean traditions of the ancient Aryans: the "fall" is true and there is no person who has survived the "nights" that follow the "Days of Manifestation", whether Yugas or manvantaras, when the Demiurge, like a horrifying monster, reabsorbs into his substance the famous "material creation".

Of particular importance to us will be the concept of Kaly Yuga, the esoteric equivalent of the Aegean Iron Age, which we will expound according to the Hyperborean Wisdom. But first we will say two words about the "Golden Age".

As we have said, the "Golden Age" is an exoteric figure founded on the perception of the hyperborean origin of the spirit. But perhaps it is worth clarifying why in the different civilizations the image of the "earthly paradise", which is a transcendent idea, always appears linked to this imitation of the "origin", which is a transcendent idea. For example, in the Epic of Gilgamesh a paradise inhabited by Enkidu is described, and so is "the garden of the Hesperides" or the "Elysian Fields" in the Greek myths; not to mention the Bible or the Aryana Vaiji, the paradise of the Parsis, etc. Here the following hyperborean criterion should be adopted:

1<sup>o</sup> - The "fall" of primordial man, and all the myths that allude to it, are distortedly referred to the chaining of the immortal spirit to matter; his captivity and slavery to the work of the Demiurge. There is, then, a veiled reference to "origin".

2<sup>nd</sup> - The "earthly paradise" IS A REMEMBRANCE OF THE PASU. In effect: when the Si-ddhas enter the Solar System, they find on Earth a hominid, ancestor of the pasu, which was all that the Demiugo and his Devas had been able to achieve after millions of years of "evolutionary unfolding" of the manu. But this miserable creature, which perhaps for that reason did not evolve, was in a true "paradise", happily enjoying and under the care of the Devas. After the betrayal of the Siddhas, because of the Mystery of Love, the pasu began to "evolve" more quickly due to the contribution of the hyperborean lineage and the captivity of the spirits coming from Venus. However, the memory of that era of complete happiness and total idiocy was preserved in their genetic memories. As we stated before, "the hyperborean spirit is necessary in the Demiurge's Plans because it is a maker of culture": it is enough to observe the qualitative and formal richness of the myths of the Golden Age to prove it. In such cultural hybrids, the primitive (animal) images of the pasu have been transformed until they have adopted a "mythical", that is to say, archetypal form, thanks to their "adaptation" to the superior patterns of the Hyperborean Race. Only in this way can there be "evolution": when a cultural structure is capable of containing assertions (symbols) that make possible the process of the psychoid archetypes. In the "myths" of the Golden Age, better than in any other, this double content, which is the basis of "culture" (and the proof of the Betrayal of the Siddhas of the Tenebrous Face), can be verified: a genetic memory of the pasu (the "earthly paradise") and a blood memory of the Hyperborean spirit (the "divine origin"); their "combination" gives the different myths of the Golden Age.

8 - We have explained in definition "c" what is to be understood by an Age, and then we explain this definition, which is worth recalling now: "A historical Age is the conjunction of humanity, during such a period, and of a Manu Archetype, to which it is subordinated, evolving towards its concretion". We also know that an Age is a macro-structure and that this is the concrete manifestation of the evolutionary process of Manu; therefore, in the Age, progress is made towards a perfection whose ultimate concretion is the entelechy of Manu: the realization of the Plan. But this perfection is, for the chained spirit, a catastrophe, as the hyperborean concept of Age (Aegean, Sumerian, Indo-Aryan, etc.) affirms, as we have seen in Ovid's example. We are now interested in referring to the present "Age", of "iron" or of "Kaly".

In the present Age humanity "progresses" tending towards the entelechy of Manu (Vaisvasvata). It should therefore be called "Vaisvasvata Yuga". What is the reason for the name Kaly Yuga? First of all, let us remember that such a name comes from the Hyperborean Wisdom and that, therefore, it must have a special significance for the awakened viryas; a sort of "message" expressing some kind of esoteric "orientation". Indeed: behind the suggestive name of Kaly, chosen to designate our epoch, is hidden a Greater Mystery, which is known as the Mystery of A-mor. We mentioned it in the allegory of the prisoner, and now we will try to approach an aspect that touches us very closely to the Westerners of the twentieth century. But we must make it clear that this Mystery is immense, as great as the drama that each one of us has to live in human existence; and for this reason we can only aspire to give some indications, to highlight signs, that will guide those who seek to free themselves from the evolutionary chains in the direction of the truth. However, to achieve this end, we will have to depart, as we have done on other occasions, from the orthodox concepts that constitute dogmas today, and go back to very ancient meanings taught by the Hyperborean Wisdom. We shall then begin by defining Kaly.

For the Hyperborean Wisdom, the incorporation of Shiva, together with Vishnu, to the Demiurge Brahma is equivalent to the union of Christ with the Demiurge Jehovah-Satan and the Holy Spirit. Both trinities are exoteric, proper to religious cults and, therefore, historically late. Before the formation of the myth, the Gods acted separately and we have already explained how the Demiurge imitated with Jesus-Christ the historical Atlantean figure of Christ-Lucifer. Shiva, like Christ or Apollo, has been from the beginning the image of Lucifer, the Great Chief of the Hyperborean Siddhas; and only the imitative passion of the Demiurge and the imagination of the Priests could have conceived a trinitarian association. There is a great irony in all this; for Lucifer represents absolute individuality, that is to say, absolute freedom; and he could hardly be associated with the Lord of Slavery, the One who prevents all freedom. In order to refer to the Mystery to which the name "Kaly Yuga" alludes, we must therefore go back to its hyperborean meaning, which bears little relation to the religious concepts of Buddhism and the various Hindu schools of yoga.

These clarifications apply especially to the black Kaly, the "wife" of Shiva, who is considered exoterically as a "negative aspect" of Parvati, his "white" wife. By the religious, i.e. mythical, way, the syncretism goes so far that Parvati is in turn Shakti, the "creative energy" of the Living Universe. Here, as with Shiva, we will refer to the Hyperborean Wisdom which teaches that Kaly, as well as the Egyptian Isis, the Babylonian Ishtar, the Roman Venus, the Greek Aphrodite, the Chinese Shing Moo, the Gnostic Sophia, etc., are all images sprouted from the "white" energy of the Living Universe.

of the blood memory of the hyperborean lineages. Blood memory, we say, but of whom: of LúCIFER's "wife", whom we may well call Lillith from now on. But this, as everything we have been saying, requires some complementary clarifications. For this purpose, we will expound certain concepts of the Hyperborean Wisdom; but let us remember at all times that we are looking at things FROM THE ORIGIN and that, although the Names have reached our days, the conceptual content that we give them here is very ancient and esoteric.

First: The "Hyperboreans" are members of a Cosmic Race in which there is a sexual differentiation. This statement means only that its members are male and female IN THIS UNIVERSE; we can know nothing about what happens outside it.

Second: Sex, among the Hyperboreans, does not fulfill the function of procreation. The Race has not diminished since it has been in material captivity BECAUSE IT IS IN- MORTAL; but neither has it grown.

Third: The sex of the Hyperboreans has nothing to do with the differentiation into pairs of opposites that characterizes the creation of the Demiurge. The coming, and the subsequent captivity, of the Hyperborean spirits is much more recent than the origin of the creation of the Solar System; not to speak of the colossal antiquity of the Universe of the One. When they penetrated through the "gate of Venus" the creation was already consummated, the opposites separated, and man or hominid inhabited the Earth. It is not correct, then, to attribute to the Hyperboreans a PRIMORDIAL ANDROGYNIA. The one who went through an androgynous evolutionary stage is the pasu.

This process is engraved in the genetic memory, which can also be recognized in human physiology by observing the endocrine glandular bisexuality; and that is why in cultural compositions the two mnemonic ascendants intermingle: the genetic of the pasu and the minneic of the hyperborean. We have already explained that culture arises from similar combinations, and it will not be difficult now to understand why the religious images of Shiva and Kaly appear confused.

THE HYPERBOREAN SPIRITS ARE ABSOLUTELY DIFFERENTIATED BY SEX. IT HAS ALWAYS BEEN SO SINCE THEY ARRIVED IN THE PHYSICAL UNIVERSE, AND THERE IS NO RECORD TO PROVE OTHERWISE. THE PASU, ON THE OTHER HAND, HAS PASSED THROUGH AN EVOLUTIONARY STAGE IN WHICH HIS BODY WAS ANDROGYNOUS, LONG BEFORE ARRIVING AT A "BIOLOGICAL" DIFFERENTIATION OF SEX. BUT THE PASU'S SOUL HAS NO SEX. IT CAN INCARNATE INDISTINCTLY IN

MALE OR FEMALE BODIES.

Fourth: There are, then, masculine and feminine hyperborean spirits. However, we always refer especially to the figure of the awakened virya as "hero" or "warrior". Are there not hyperborean women, that is, female captive spirits incarnated in the physical bodies of pasu women? To answer this question, we must touch on one of the most hidden aspects of the Mystery of Love: the Hyperborean Wisdom affirms that the primordial fall was led overwhelmingly more by the male spirits than by the female ones, who were chained from then on to the evolution of the pasu. So, what became of the missing female spirits, those who were not deceived by the Traitor Siddhas and who never incarnated: they await the return to the origin of the viryas in Valhalla: they are the Walkirias of Nordic mythology. But it is more important for us to know the role played by the KALY WOMEN in the drama of human life. We will soon find out.

These four concepts will allow us to face that aspect of the Mystery of Love that "touches us, Westerners of the twentieth century", as we said before: it is the one that refers to tantric practices.

We will not make here a summary of the philosophy and tantric yoga; to acquire this knowledge there are excellent books that we recommend reading<sup>1</sup>. Instead, we will refer to some esoteric symbols that every tantrika should know and show why the practice of sexual yoga often "fails" among Westerners; that is, it often has disastrous effects on the physical and mental health of the sadhaka<sup>2</sup>.

We will therefore take most of this philosophy for granted.

Tantra yoga is based on the "Science of Breath", which deals with the "res-  
of the Demiurge in the manvantara, a period of time during which he is

---

1 *From the traditional texts such as the KULARNAVA TANTRA, the TAN-TRAKAUMADI, the SHAKTI SANGANA, the TANTRA SATUA, etc. The books of JEAN RIVIERE "Tantric Yoga" and "Ritual of Hindu Tantric Magic"; of ARTUR AVALON "The Serpent Power" and others; of OMAR GARRISON "Yoga and Sex"; the classic of RAMA PRASAD "The Subtle Forces of Nature"; and all the work of MIGUEL SERRANO should also be read.*

2 *Sadhaka= officiant of tantric practices, "disciple" of the Kaula Schools.*

The worlds are manifested by the rhythmic movement of the five Pure Principles or tattvas of the Universe. In man, in his biological body, all the cosmic processes are reproduced and the five tattvas intervene analogously; and also, in his sexual differentiation, the duality that characterizes nature is dramatically reflected. But the function of sex in the pasu was defined from the beginning by reproduction, and NO OTHER PURPOSE THAN THAT WAS EVER FORESEEN.

In other words: the human body is the concrete expression of a Manu Archetype which develops during a whole Age, within the framework of a "Root Race"; in this Archetype sex fulfills, FROM THE BEGINNING, a reproductive function; hence in the body of the pasu (or lost virya) sex aims fundamentally at reproduction and a proof can be seen in the synchronization with the lunar rhythms exhibited by the woman's period of fertility: The sexual function is thus connected to the rhythms of the Great Breath and is bound to the process of the Manu Archetype.

Only the incorporation of the hyperborean heritage into the blood of the pasu has possibly  
 biliterating the idea of giving sex another meaning outside the mere animal reproduction. Idea that, on the other hand, would have been inconceivable by the miserable pasu.

There have been many Hyperborean methods of harnessing sex for the "strategic reorientation" of the virya in the millions of years that the spirits have been in captivity. Tantra Yoga is only the latest of these, which the Hyperborean Wisdom has taught for the "Kaly Age", and which has been subjected to terrible cultural confusion through syncretism with Buddhism, Samk-ya dualism, Vedanta monism, the equating of forces with the myths of the Hindu pantheon, etc., etc., etc. Today Tantra is an unrecognizable philosophy, from the point of view of the Hyperborean Wisdom, which the Synarchy has launched in the West as one more of its consumer goods. But what makes it particularly harmful is the practice of sexual yoga without possessing the ancient symbolic keys, especially the Hyperborean concept of the "yogini" or tantric woman, which is the main condition for yoga to fulfill its purpose.

Many imprudent people, in the West, throw themselves into the practice of yoga without understanding that such exercises are a minimal part of a philosophy of life or way of life that in the East is cultivated from birth to death. As long as it is a question of yogas that only tend to strengthen mental concentration or physical vitality, the danger is not greater; but when one comes into contact with the igneous energies as in tantra yoga, the situation changes unfavorably for the

**Nimrod from**

**Rosario**

health of the imprudent person.

**363**



However, we are not going to condemn the practice of tantric sexual techniques but to indicate WHEN A WESTERN CAN RESORT TO THEM safely, since they are part of the Hyperborean Wisdom.

First of all, let us remember that "strategy is the way of life of a hyperborean virya" and that "strategy is a means to an end". The declared end of the hyperborean virya is: the return to the origin. The conquest of this end implies different steps: the "awakened virya" is the one who has glimpsed the origin and has oriented himself; in the search for the Vril he can follow any of the seven ways of liberation that are heard in the Song of Love of the Hyperborean Siddhas; one of such ways, that of strategic opposition used by the berserkir initiates of the S.D.A., has already been mentioned and we have already mentioned it, We have already mentioned it and we will refer to it with special attention hereinafter; but Tantra is another of the secret ways of liberation and, therefore, pursues the same declared purpose: to awaken the virya and lead him to the origin, to the conquest of the Vril.

How does Tantra propose to fulfill this objective? By transmuting the physical body of the sadhaka and immortalizing it during the practice of maithuna, the sexual act; thus freeing it from the Karmic chains and allowing the consciousness of the hyperborean spirit to manifest in it; having reached such a state, with its VRAJA body and its awakened gnostic consciousness, one is already a Siddha, a being capable of applying the pure possibility that the Vril offers and abandon, if preferred, the material Universe.

This is the true purpose of Tantra; and those who only take advantage of its practices to obtain greater pleasure from the sexual act are mistaken.

We just recalled that the way of life of a hyperborean virya is "strategic". If Tantra is considered as a "strategy" for the return to the origin, then there is no objection for the virya to incorporate tantric techniques into his own strategic way of life. If he does not lose sight of the aims of any hyperborean strategy, tantric practices cannot harm him; but it is important to establish clearly when it is appropriate to follow this path and when it is not (to the Western sadhaka). For this we will refer to the fundamental Tantra technique of the "wet way": the retention of semen during orgasm.

The maithuna or sexual union is, in Tantra, the culmination of a ritual; and this ritual is reached after a long philosophical and practical preparation. Especially, one learns to control the breathing and heart rate at will, and then to distinguish the naddhis, or internal energy channels, and the chakras, or energy vortexes. The

**Nimrod from  
Rosario**

**365**

main chakras are seven, located more or less at the level of the plexuses, above the plexuses.

a major channel called Shushumna, which runs parallel to the spine.

From the lower chakra, muladhara, two minor chakras called Ida and Pingala, which wrap helically around the Shushumna channel, cross at each plexus under the other chakras, depart from the lower chakra, muladhara. The sixth chakra, Ajna Chakra, is located between the eyebrows, above the pituitary gland, and there the Shushumna, Ida and Pingala chakras also converge. Above the Ajna Chakra is the Sahasrara Chakra, Brahmachakra or Brahmarandra, which we will discuss shortly.

We are quoting what is strictly necessary for our explanation, but, naturally, additional knowledge is required to understand it, which can be acquired in specialized works.

In the Muladhara is coiled and obstructing the Shushumna channel the "Kundalini being", that is to say, the igneous Shakti, expression in the physical body of the Demiurge's shaping power.

The declared EXOTHERIC objective of all yoga is to awaken Kundalini and make it rise through the Shushumna channel, from chakra to chakra, up to the higher Ajna Chakra center. From there, the force of Kundalini will allow to extend the consciousness to the other subtle bodies of man and to reach the Sahasrara or Thousand Petal Lotus, where the fusion with the Demiurge Brahma is achieved, through a "jump of consciousness" towards absolute immanence. With the consciousness in the Sahasrara an ecstasy is achieved that consists, paradoxically, in the dissolution of the individual consciousness, after its fusion or identification with the "cosmic consciousness", that is: with the Demiurge. For the Hyperborean Tantra, this exoteric objective, the state of trance or Samadhi and the union with the One or Nirvana in the Sahasrara, is simply suicide.

The esoteric objective of Tantra, as we have already said, is the same as that of any hyperborean strategy: the mutation of the animal nature of the pasu into the divine and immortal nature of the Siddha. Therefore, it should be made very clear that the Hyperborean VIRYA, BY MEANS OF TANTRA, DOES NOT SEEK ANY FUSION WITH THE DEMIURG, BUT, ON THE CONTRARY, SEEKS TOTAL ISOLATION FROM HIM IN ORDER TO GAIN THE INDIVIDUALITY OF HIMSELF.

Can the esoteric objective be achieved by means of tantric yoga? Yes, as long as one has a clear idea of "what" means "awakening Kundalini" and "for what" and "when" one can safely resort to the seminal retention techniques in the maithuna. Let's go by parts.

Many confused viryas in the West, who are in the habit of unwisely playing with the tattvas, believe that "awakening Kundalini" is something like setting in motion a reflex energy, which acts of its own accord, following some unknown law. Contributing to this error is the idea that the Shushumna and the other naddhis are "channels" and therefore "must channel the energy through a kind of circuit, without being diverted or overflowing," analogous to the "circuits" of the nervous system. It is also believed that the substance of Kundalini is "a fire" or "a heat" or, at any rate, the force of a natural energy. But Kundalini is much more than these beliefs.

We will resort to a concept of the Hyperborean Wisdom to define Kundalini; but let us bear in mind that it would take several books to base this explanation on the "essence" of Kundalini and that, as the criterion followed here, it is much more brief and suggestive to refer to her by analogically describing her "behavior", which obviously does not conform to that of a blind force.

We have already said, when speaking of the Acoustic Kabbalah, that "In truth the Universe has been made from a number of different elements, no more than twenty-two, which support, by their infinite combinations, the totality of existing forms". These twenty-two elements (or fifty, according to the Indian Traditions), can be considered as sounds or "bijas", that is, universal acoustic roots. Thus, it follows that every "form" is supported by a "name", which is the formulation of a certain combination of the principal bijas. But, as we said elsewhere, a "concrete form" is the expression of a "state" in the evolutionary process of the Archetypes. There is, therefore, a relationship between the Archetypes and the "sacred names" of all things, which is worth knowing.

In the beginning the Archetypes are "thought" by the Demiurge, The One (Brahma), and projected into the "great primordial psychic ocean" or "akasa", where they remain in a potential state. It is the Breath of the One, that is: the utterance of the "names", the impulse that initiates the evolutionary process of the Manu Archetypes who, unfolding in matter, determine the existing forms; forms that progress towards entelechy, towards a more complete manifestation of their own archetype. It is true, then, that "to each thing" corresponds a secret, archetypal name; a concept that has always been handled by magic and that is deeply developed in the philosophical systems of India, but which, fundamentally, constitutes the basis of the Acoustic Kabbalah.

When the Demiurge pronounces the Words, that is to say, modulates the Breath,  
he ad-  
wants the aspect of a cosmic Word or Logos. By the characteristic it possesses

the space of being an expression of the archetypal monads, whose manifestation are the psychophysical Quanta of energy, trutis or U.E.V.A.A.C. units, the Breath of the Demiurge, his Words, reach all points of the cosmos, making it possible for forms to take shape wherever matter allows the evolutionary processes of each particular Archetype. This interpenetration is evident in the microcosm of the human body, where all the processes of the macrocosm are reflected. In particular, we will cite that part of the microcosm which represents the "Logos" or "Word" aspect of the macrocosmic Demiurge: Kundalini.

Kundalini is, in the human body, the "creator" or form-forming Logos, analogous expression of the Solar Logos or Cosmic Logos. It is "asleep" because the microcosm HAS ALREADY BEEN CREATED, and it evolves following the process of the Manu Archetype of its race. But the main reason for the inaction of Kundalini is the rhythmic synchronization of the microcosm with the macrocosm of The One; for such synchronization means that there is simultaneity of processes and that the evolution of the microcosm will not deviate from the archetypal process.

Being by nature a Logos, the "awakening" of Kundalini will involve the pronunciation (japa) of certain names (mantras). Indeed: during the ascent through the Shushumna channel, and during its "rest" in each chakra, Kundalini PERMANENTLY recites bijas and mantras as befits a true Logos, thus fulfilling a function of superior quality to that attributed to it by vulgar belief: "igneous energy", "serpentine fire", etc.; but in all cases: force of reflex action.

This character of "Logos" is responsible for the fact that all yogas that propose the exoteric purpose of "awakening Kundalini" end in the "fusion with the Demiurge"; in the absolute identification of the "I" with the cosmic One. This effect is due to the "harmonizing" or synchronizing function that Kundalini fulfills by REPEATING THE NAMES (bijas or mantras) OF EACH PART OF THE PHYSICAL BODY (and of the subtle bodies) AND VERIFYING THAT THEY CORRECTLY REFLECT THE COSMIC PROCESSES.

By this "behavior" of Kundalini, yogis who effectively seek to attain the Samadhis or contemplative ecstasies, and even fusion with the One, achieve astonishing results; this must be the case since the Logos, awakened in the microcosm, faithfully reproduces the bijas of the Cosmic Breath, balancing all disharmonies and synchronizing all biological rhythms. It will now be understood why we described the pursuit of the exoteric objective of the yogas (awakening of Kundalini) as suicidal for those who seek abstract individuality: BECAUSE IT FURTHER INCREASES THE MATERIAL ENCADENMENT OF THE VIRYA.

It must be perfectly clear, then, that Kundalini MUST NOT BE AWAKENED if one does not possess the keys to harness her RE-CREATING power; for HER VERB can represent both the Will of the One IN THE MICROCOSMOS to ensure evolution, and one's own will to produce mutation.

The Hyperborean Wisdom assures that Kundalini has the "secret mission", among others, to intervene immediately "IF THE NATURAL LINKS BETWEEN THE MICROCOSM AND THE MACROCOSM ARE ALTERED, FROM THE MICROCOSM, BY YOGA PRACTICES; IN THAT CASE KUNDALINI WILL ATTEMPT TO RESTORE THE NE-.XOS COMPLETELY RECREATING THE BODIES (physical, emotional, mental, etc.) OF THE MICROCOSM TO CONNECT OR RE-CONNECT IT WITH THE DEMIURGE; BUT IF THIS IS NOT POSSIBLE, KUNDALINI WILL TRY TO DESTROY THE MICROCOSM, SINCE IT NO LONGER FULFILLS ITS DESTINY TO EVOLVE TOWARDS THE ENTELE-.QUIA OF THE MANU ARCHETYPE". One understands, then, the danger to which a hyperborean virya who hates the work of the Demiurge is exposed, if he "awakens Kundalini" and it plunges him into a nirvanic ecstasy: it is possible that from it derives madness or serious injury to the physical or subtle body. That is why the Hyperborean Wisdom tells the virya to play with yoga:

*"what will you do, you who still believe that SEX 'IS  
BAD' when Kundalini says LAM...?*

*and your gonads DRY?*

*And: what will you do, you who still suffer from ANGUSTIAS  
AND FEAR, when Kundalini says VAM*

*and your adrenal DISSOLVES?*

*And: what will you do, you who still SUFFER*

*AND ENJOY the things of the world,*

*and you still feel the FIRE of*

*anger and the COLDNESS of*

*indifference, when Kundalini*

*says RAM*

*and your pancreas IS CALCULATED?*

*And: what will you do, you who still LOVE*

*AND HATE, when Kundalini says YAM*

*and your heart explodes AND BECOMES VOLATILE?*

*And: what will you do, you who still SPEAK AND*

*LISTEN, when Kundalini says HAM*

*and your thyroid is DISINTEGRATED?*

*And: what will you do, you who still SEE  
WITHOUT SEEING when Kundalini says OM  
and YOUR DEATH ensues?*

These questions and many more are asked by the Hyperborean Wisdom TO THE HYPERBORNE VIRYA, that is, TO WHOM THE DEMIURGO WILL TAKE AS ENEMY and will try to destroy. However, the answer does not imply ABANDONING the practice of yoga "A PRIORI" but, as we said before, to operate strategically with the tantric techniques after knowing "what" it means to awaken Kundalini (something we have already explained) and "for what" and "when" one can safely resort to the techniques of semi-nal retention in the maithuna. We must investigate, then, these last two conditions.

To know exactly "when" a virya can successfully use the sexual techniques of tantrism, we must start from a fundamental affirmation of the Hyperborean Wisdom: the sadhaka MUST NOT LOVE "WITH THE HEART" THE WOMAN OF FLESH.<sup>1</sup> This revelation will surely be taken with surprise or disdain by those who perform tantric practices "with the beloved woman", a figure very dear to the western fantasy. Those who do so, the Hyperborean Wisdom calls them simply "ignorant viryas", for they "ignore everything about Kaly".

It is truly a laughing matter to think that ignorance goes so far as to believe that in the maithuna with the "wife" (or "friend" or "lover") one will find the liberation promised by the sacred oriental texts: that is to have a poor idea of Shiva and Kaly. But the laughter ends here; for such ignorance is extremely dangerous since, for a Western couple, the results are usually disastrous; and it is more likely that instead of the longed-for "liberation" what is obtained are irreversible psychic alterations.

One should not, therefore, love the woman with whom one joins to practice the tantric maithuna; but, then, what feeling should one feel towards her: NON-FEELING. We have raised this question to highlight the difficulty that exists in the West to conceive a NON-AFFECTIVE relationship with the woman, a difficulty that is not present in the minds of the Orientals, FOR WHOM THE TANTRIC METHOD WAS REVEALED. But it is not a question here of a "racial" differentiation of biological origin that manifests itself in different psychological attitudes towards sex and the

---

<sup>1</sup> *The WOMAN OF FLESH is that which the Hyperborean Wisdom also calls EVA WOMAN. These denominations will be clarified later; but here, the "woman of*

*flesh" should be considered as a "common woman" or "pasu woman".*



The "acquired character" of the Westerners, which registers a moment of its historical appearance: the 13th century.

Concretely, it was the Cathars who, within the framework of their A2 Strategy, planned the collective mutation of Western civilization and launched, for this purpose, the movement of the troubadours.

The Cathars had two problems to solve. The first one, which we will talk about again, was that the Benedictine Druids with their Gothic revolution based on the Acoustic Kabbalah produced infernal machines that had, and have, the power to "tune" the inhabitant of Europe with the psychoid Archetype of the Hebrew race that, as we said, was updated by Jesus Christ. Those stone machines are the Gothic cathedrals; and against that shaping power the Strategy of the "pure men"<sup>1</sup> pointed in the first place. The second problem was that, as the Hyperborean Wisdom teaches, "to mutate a human community it is necessary to count on an enormous amount of collective psychic energy, subtracted from the process of the psychoid Archetypes of the Demiurge". It will already be seen in book 4, when studying the laws of the Psychosocial Strategy of the SS, that such energy must be "contained" in a psychoid Archetype or egregore built for this purpose by berserkir initiates duly instructed in the Hyperborean Wisdom. For the time being, we would like to point out that, in this case, this Archetype was indeed created by the Cathars and that it corresponded to THE IMAGE OF THE LUCIFERIC WOMAN, LILLITH. But this archetype was embodied in the terrestrial psychosphere as an action of war by Lucifer himself who, FROM BEHIND VENUS, WITH THE GREEN RAY, PROJECTED THE IMAGE OF HIS

WIFE LILLITH. So the Archetype of "The Lady", such its profane name, corresponded to a hyperborean spirit WHOSE SEX IS NOT ASSOCIATED WITH THE BIOLOGICAL PROCREATION FUNCTION. Precisely, the energy with which the Lady Archetype would be fed would be obtained from the libidinous sublimation that the gentleman would make of his sexual energy by seeking, in common women, the face of the hyperborean woman, of which the Song of Love of the Siddhas speaks in the blood of the lost viryas. And such is the characteristic of the Lady Archetype, its sexual dissociation, that the gentleman can only project it upon "unattainable", "light" or "foreign" women, and never upon one who can be easily possessed. This condition is so rigorous that the beloved lady, that is, the woman in whom the lover projected the Archetype, is transformed into a "common woman", "loses her charm", her "beauty" is decomposed, when she is "conquered" and possessed. Then love is transformed into pain and the knight, disenchanted, is driven to look again for another unattainable Lady whom he will adore and try to conquer. From

---

**Nimrod from**

**Rosario**

1 *Pure Men = Cathars.*

The embodiment of the Lady Archetype generates a tendency to the idealization of women that has no historical antecedents prior to the thirteenth century.

In book 4 it is shown that a psychoid Archetype can only be made conscious when it has been DESCRIBED. In order for an Archetype that was embodied without the intervention of the Demiurge to act socially - so that The Lady can be sought - it is necessary for someone to "describe" it, that is, to reveal it to the people. And that was, precisely, the esoteric mission of the Provençal troubadours: to describe The Lady; to make the European virya remember the primordial image of the hyperborean woman; to awaken her Minne. But, to describe something, it is necessary to have seen it before.

Where did the troubadours get their previous vision of the Lady: from their Cathar initiation in the French Languedoc, where they learned the "galla ciencia" and "trovar clus". The Lady, SURROUNDED BY STONE FENCES (towers or walls) which WERE DESCRIBED in the love songs, is a clear proof of the strategic-hyperborean origin of the troubadours' knowledge.

The second problem that the Cathars had to solve was the need for European society to have a certain collective psychic energy as a prerequisite for its mutation. We have already seen part of the solution adopted: the creation of a psychoid archetype whose purpose would be to provoke erotic sublimation in the medieval virya. It now remains for us to determine in what way this Archetype could be the solution to the second problem.

We can know this if we remember that a psychoid Archetype is nourished by psychic energy, taken from the "universal collective unconscious", by means of which its evolutionary process develops. To obtain such energy the Archetype "captures" the attention of the self by emerging before its sight as a cultural object of the superstructure; the Lady Archetype, which is "psychoid", i.e. "external", works no differently. Let us see what the characteristic mechanism is. When the gentleman experiences SEXUAL DESIRE, he "triggers" the conscious emergence of the Lady Archetype, establishing, immediately, the CERTAINTY that the desired woman (whom he can effectively "touch" or "possess") IS NOT THE LADY OF HIS DREAMS, the ideal woman. Seen "from afar" the woman of flesh is a representation of The Lady; and his contemplation of her, or desire for her, feeds the Archetype with energy drawn from the libido. But if "the approach" is sufficient to culminate in sexual mating, in which the "direction of energy" has been "reversed," then the Lady Archetype withdraws, "under the threshold of capture," and the woman of flesh is left to her own "charms. As the spell is broken, desire is likely to increase inextinguishably; but not toward the woman of flesh who has been devalued by the absence of ideal attributes, but toward another "ideal woman" in whom it is

will repeat the process of the Archetype. The Archetype "counts" on this reaction, which he itself provokes, to nourish itself permanently: this is its way of proceeding.

Naturally the Lady Archetype is a terrible egregore in which the Cathars hoped to store enough psychic energy to achieve, through its instantaneous discharge when it suited the A2 Strategy, the collective mutation of countless lost viryas into immortal Siddhas. The failure of the A2 Strategy, and particularly the destruction of the Cathar elite in the bonfires of the Druid Pope Innocent III, PREVENTED THE EGREGORUS FROM BEING DISCHARGED IN TIME.

AND DEACTIVATED after an esoteric operation of Psychosocial Strategy known as ARCHETYPIC METAMORPHOSIS. Since then, the egregore has not ceased to feed in a sort of symbiosis so close that it has ended up irreversibly modifying the behavior of the lost "western" viryas. But, without the control of the Cathar initiates, who would have "directed" the behavior of the egregore, its action has ended up being harmful, far from inspiring those beautiful images of the hyperborean woman that prevented to love the woman of flesh. On the contrary, the passing of the centuries, the numerical increase of the population and certain cultural processes have modified the profile of the Lady Archetype, which has finally become a monstrous vampire, responsible for many of the neuroses suffered by the contemporary virya. In order to favor its entelechy, it has forced the idealization of the woman of flesh to the point of exaggeration, succeeding in completely idiotizing the Westerner, who has now associated with the sexual act "the duty" of experiencing a "love" that no one knew before the thirteenth century.

The modern virya, imprisoned in the web of feelings and tenderness, will no longer know how to distinguish the woman of flesh, for she now lies under the disguise of her archetypal projections. And the woman of flesh, ontologically confused by the idiotized masculinity of the virya, will break free from its control, will veer erratically between her own sexual limits and, finally, will masculinize herself, in an unconscious attempt to avoid the projection of the Archetype. The virya will then suffer from a myriad of sexual disorders, from impotence and dissatisfaction to homosexuality, since the latter, so prevalent among the current male population, is the effect of a permanent capture of the self by the Lady Archetype, who thus absorbs the totality of available energy.

Of course, after the failure of the A2 Strategy, the lack of control of the Lady Archetype has been capitalized in favor of the Synarchy Strategy by the Demons of Chang Shambala, especially to reinforce the collective influence of Jesus Christ, who thus became a perfect mirror for the viryas to en-counter the beloved image and sublimate the energy that the Archetype needs in order to

to continue its process. Of course, the image of Jesus became feminized to the same extent that the woman of flesh became masculinized; but this is of little concern to the Sinartia, since it does not affect the "non-Christian" peoples, of which the main one is the Hebrew "chosen race".

The descriptive action of the troubadours was circumscribed to the European sphere<sup>1</sup> and therefore did not affect the Asian communities, where the tantric techniques floated until the XVIII century, that is, until the moment when the "European civilization" fell upon Asia and the viryas of India and Tibet were astonished to see that the European man did not know the woman of flesh. But the damage was already done; to "progress" the Asian had only one way: to imitate the European; that is to say, to love and respect the woman of flesh, ONLY ONE IN LIFE, AND TO DESIRE ALL OTHERS, SUBLIMING THE ENERGY OF EROS. In this way the Asians would also lose sight of the woman of flesh, they would end up, except for the most heretical tribes, completely idiotized, confusing Kaly with the terrestrial Shakti, with Mother Earth or Materia. From this catastrophe concludes the beneficial influence of tantric yoga; since it requires for its realization to clearly distinguish between the woman of flesh and the hyperborean woman. And such a distinction, it is worth repeating, cannot be made "if you love with your heart to the woman of flesh".

So we come back to: "when" a Westerner can use the techniques described above?  
 xuals of tantrism WITHOUT DANGER?

In order to find out "when", we start from a statement of the Hyperborean Wisdom: "the sadhaka should not love with his heart the woman of flesh". Now we know why: the "love" experienced for the woman of flesh is a conscious expression of the evolutionary process of the Lady Archetype, which masks her and prevents us from knowing her "true Face". But the Lady Archetype has acted freely for more than seven hundred years, producing the incorporation of hereditary characters in European lineages, especially the "modulation" or "profiling" of the unconscious "anima" according to her image. And considering also that the egregore is at present tremendously potent, IT MUST BE ADMITTED WITHOUT DISCUSSION THAT, IN THE WEST, IT IS VERY DIFFICULT NOT TO LOVE THE FLESH WOMAN.

---

1 *We do not attach much importance to the influence that the troubadours*

**Rosario**

*may have exerted in the East during the Crusades, since all Western influence there was swept away by the Arab and Turkish expansion of Islam since the 13th century.*

It is understandable, then, that there are viryas who find it virtually impossible NOT TO LOVE their women of flesh; and this need not be a cause for concern IF, IN THAT CASE, THEY PRUDENTLY REFRAIN FROM PRACTICING TANTRISM.

But what should the lost viryas of the West who seek "liberation" from material chains do then: the Hyperborean Wisdom advises them to turn to the other secret ways to undertake the return to the origin, IF THEY ARE STILL CAPABLE OF LOVING THE Fleshly WOMAN. This advice should not be disregarded; the risk is enormous: by the inverse way of return, following the Voice of the pure blood, it is possible to REINTEGRATE THE SELF WITH THE SELF-MYSELF, to bring the present consciousness to identify itself with the spirit or Vril and, in a Gnostic STRIP, to TRANS-FORM INTO "ABSOLUTE INDIVIDUALITY". On the contrary, an improper use of tantrism can lead to a nirvanic samadhi in the Sahasrara that implies a harmonizing physiological recreation by Kundalini and an identification with the Demiurge: the "fusion with Brahma"; in this case, after the "bad trip", the consciousness of the virya would not be reintegrated but fragmented in a permanent schizophrenic picture from which it will hardly be able to recover.

Naturally, there are an infinite number of different situations in which lost viryas can find themselves; from those who have already "formed a family" and love their wives as good Christians, to those who are completely ignorant of their capacity to love; how will they know "when" they can resort to the sexual practices of tantrism WITHOUT DANGER? We will answer that there is indeed an infallible way to know "when" that moment has arrived: it is the Family Test, proposed by the Hyperborean Wisdom. With the exposition of this Test, we will end the series of warnings that we have been making about the peli- gros of tantrism.

The Family Test does not refer specifically to sex, but to "blood relations", parents, siblings, grandparents, uncles, aunts, uncles, children, etc. But whoever is able to face the Family Test will not only see his questions about sex answered, but will have taken an important step towards other ways of liberation, apart from tantrism. That is why every western virya should face this test sooner or later.

It is known that the genealogy of a family can be graphed by establishing analogical correspondences with the figure of a "tree", in which the "trunk" and the "root" correspond to the ascending lineage and the "branches" to the different lineages that descend from the main trunk. As an example we represent, in figure 3, the family of Mengano, brother of Perengano and son of Montano, who in turn descends from the hyperborean trunk of the Villano. As useful as it seems to be

This analogy to determine the ascendants of a lineage, the degree of kinship or the proportion of an inheritance, is nevertheless insufficient from the strategic point of view. To demonstrate this, it suffices to point out the static, "unalterable fact" character of the scheme: "a genealogical tree is, like the plant tree that represents it, a concrete and unmodifiable fact BECAUSE IT RELIABLY REFERS TO EVENTS THAT HAVE ALREADY HAPPENED"; such is the current opinion. The scheme being unmodifiable, the inadequacy is highlighted when Mengano, for example, considers the strategic guideline of "increasing" the influence that the Villano's inheritance exerts on himself. From the analogy with the "tree" it is not clear how this would be possible: Mengano cannot be branch and trunk at the same time; if he is branch he IS NOT trunk; if he is "Mengano", the blood inheritance of the Villano lineage is the one shown in the scheme: a quarter of the original blood.

With this analogy there is, therefore, no solution; he who was born a branch cannot GROW TO BE A TRUNK and his safe function is to STAY COMFORTABLY ON HIS SIS.

The inadequacy of the scheme can be overcome by resorting to another analogy, not conventional this time, but first it is worth clarifying that a "genealogical tree" constitutes the elementary description of a psychoid Archetype called "family Archetype". The "genealogical tree" represents, then, the superstructure of the "family fact", which evolves towards the entelechy of the family Archetype. But a "family" is defined by the living members it exhibits in each epoch, rather than by the past of its lineage, because ALL LIVING RELATIVES ARE A CONCRETE EXPRESSION OF THE ARCHETYPICAL PROCESS. Let us give an example. We observe the tree of the Villano lineage; we discover that in 1910 there were nineteen living relatives of that blood; THE NINETEEN RELATIVES, EACH AND EVERY ONE OF THEM, ARE CONCRETE EXPRESSIONS OF THE FAMILY ARCHETYPE: they are "proofs" or "trials." evolutionary processes that THE BIOLOGICAL MODE OF THE PROCESS requires for the realization of the family archetype.

Every family or lineage tends towards the entelechy of a particular family archetype which is, in turn, a hypostasis of the Manu archetype. And every virya, within his own family, inevitably evolves in this direction. One CANNOT ESCAPE THE PROCESS BY REACTING EXTERNALLY, for example, by abandoning the family, by secluding oneself, ignoring it, destroying it, and so on. Even if all the relatives have died and only one virya survives, the family archetype will continue the process through him. The only way for the lost virya to avoid evolution IS INNER, PASSES THROUGH THE BLOOD AND LEADS TO THE PAST. And we have already explained



sufficiently how this inner path should be sought in the contained memory

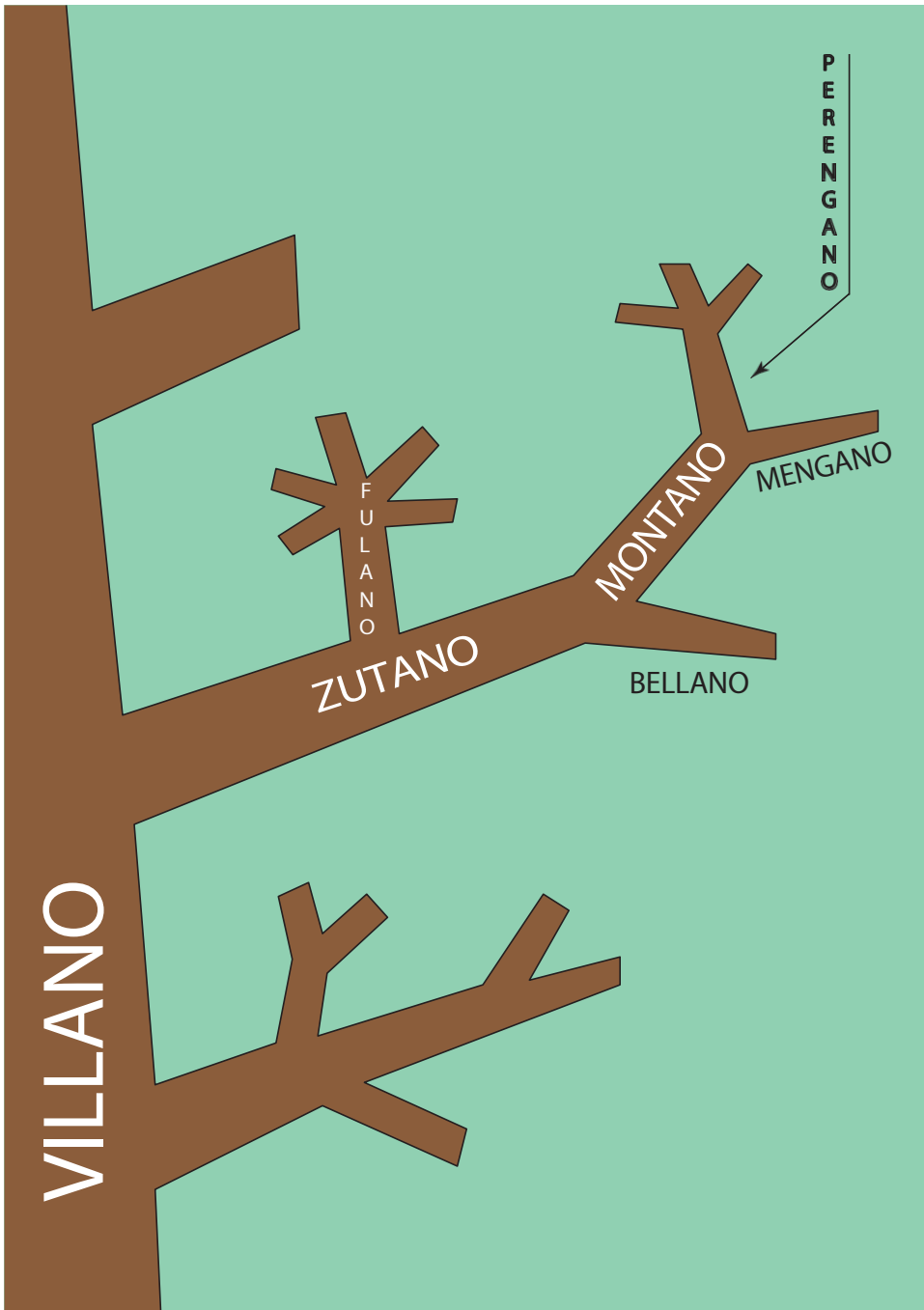

Figure 3.- GENEALOGICAL TREE: ESTIRPE VILLANO

de la Minne.

But Mengano has also understood that by continuing in his role as a branch he only succeeds in evolving in the sense of the family archetype. Looking back, he understands that he descends from a purer, hyperborean lineage, and poses the problem of RECOVERING an inheritance that lies in the past. As the genealogical tree does not show what the solution could be, as we said, Mengano decides to turn to the Hyperborean Wisdom, whose teachings affirm that "pure blood" is the only continent of the Hyperborean inheritance. For the Hyperborean Wisdom, an analogical scheme starting from pure blood should not vary topologically from the genealogical tree already seen. But instead of a tree, it considers that THE BLOOD IS EQUIVALENT TO A RIVER whose main channel is the "trunk" of the genealogical tree and whose rivers and streams, tributaries or tributaries, are represented by the branches.

Let us go deeper into this new allegory. Looking now at figure 3 we see the "Rio Vi- llano" into which flow numerous tributary branches, among which the rivers "Zutano", "Montano" and "Mengano" stand out, connected in such a way that each one channels the flow of the previous one. But the FLOW of the rivers is analogous to the PURITY of the blood. The Villano River, because it represents a purer hyperborean blood, has consequently a greater flow, a quality that can be appreciated in figure 3 by observing the great width of its channel. And Mengano, the virya who sought the inverse path of the pure blood, appears in the allegory as a simple stream of reduced flow.

Seen in this light, thegano problem does not now appear to be insoluble; for it boils down TO OBTAINING AN INCREASE IN FLOW, AND THAT IS ALWAYS POSSIBLE IN A HYDRAULIC ALLEGORY. We can pose the strategic problem ofgano in analogical terms of the hydraulic system by asking: what must be done to increase the flow of the Mengano stream and, if possible, bring it to equal that of the Villano River?

Before answering it is worth noting that the flow, RUNNING IN REVERSE SENSE, goes from Mengano to Villano, so the solution does not lie, as might be slightly thought, in widening the riverbed. Hence, the ONLY solution to this problem is to ADD THE REMAINING RIVER FLOODS TO THE MENGANO RIVER FLOW.

To fully clarify this hydraulic solution, let us consider only the Mengano stream and the Montano and Zutano rivers, which are connected "one after the other", i.e. "in series".

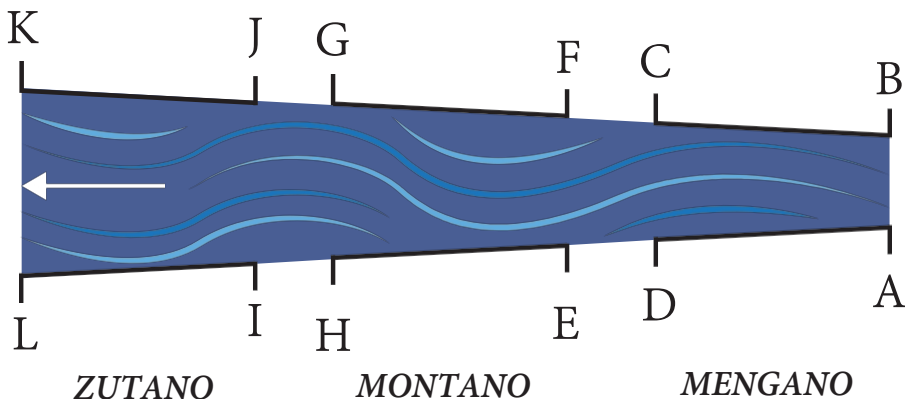

Figure 4

The Mengano is connected "by width" with the Montano, i.e.: CD with EF; and the Montano with Zutano also: GH with JI.

The solution to the problem requires altering this connection between watercourses "by width".  
and replace it with a longitudinal junction, in order to "add up the flow rates".

The theoretical layout for the three watercourses considered is shown in Fig. 5, where it can be seen that the watercourses are now connected longitudinally, "in parallel"; the Mengano, for example, has been joined to the Montano by the banks.

CB and EH.

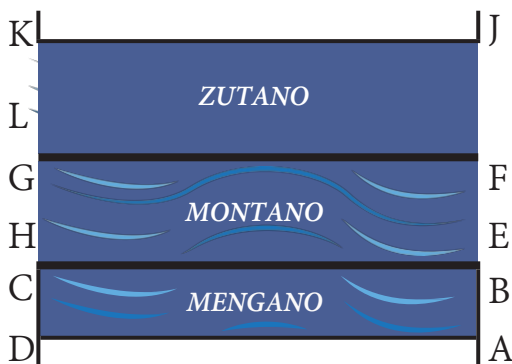
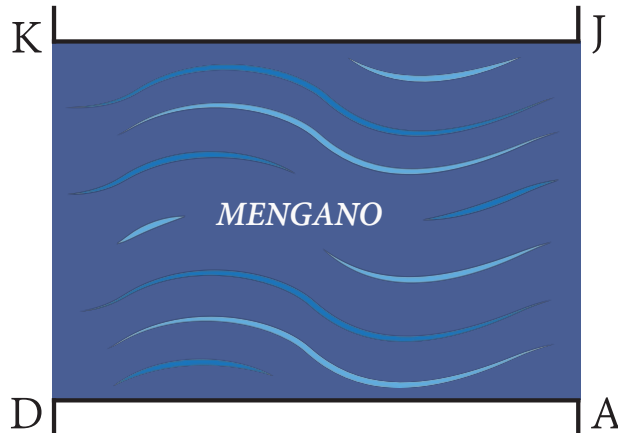

Figure 5

The final result is a new Mengano, with a much higher flow due to the addition of the flows of the Montano and Zutano rivers.



Continuing with this procedure, and after adding ALL the other tributary rivers to the Thin River, it is theoretically possible to equalize the flow of the Villano River, thus ending the problem.

Let us leave the hydraulic analogy for now and return to the strategic problem of the virya Mengano: what conclusion can be drawn from the hydraulic solution? what does it mean for the virya Mengano to "add up the flows"? To answer this question, it is necessary to transfer the hydraulic solution to the concrete genealogical plane of the family of Mengano. In it "the rivers" are equivalent to close or distant relatives, and the "addition of flows" means that Mengano MUST INCORPORATE IN HIMSELF HIS RELATIVES; ADD, TO HIS OWN BLOOD, THE PURE BLOOD OF THE OTHER MEMBERS OF THE FAMILY.

It seems crazy, but it is appropriate to ask: is this solution possible? According to the Hyperborean Wisdom: YES. And the attempt that each virya makes to make such a solution effective is what is called the "Family Test".

There is a moment of "transition" in the life of the virya: when he ceases to be "lost" because he has become aware of the Great Delusion, but has not yet "oriented" himself, and therefore is not fully "awake". In this difficult trance the important thing is to DISCOVER ONE'S OWN IDENTITY, which is buried under multiple faces or personalities. It is necessary, above all, to distinguish that part of oneself that transcends the process of the family archetype. To achieve this, two things must be done: on the one hand, the memory of the origin, the hyperborean inheritance, must be sought in the blood; and on the other hand, the REINTEGRATION of the Archetype must be achieved.

Family, the pieces of which are scattered throughout the world in the form of "blood relatives". The Family Test is intended to grant both, so that the virya overcomes the transition and finds a first orientation.

But although the Family Test aims at favoring the discovery of the true "I" in each one, and it is true that this discovery can be sought by another way, where the Test cannot be overcome by any other method is with respect to the determination of the "capacity to love". Let us remember that we should know "when" it is possible for the virya to employ the sexual techniques of tantrism without danger and that the Hyperborean Wisdom told us "thou shalt not love with the heart the woman of flesh". We have also known that "love" for the woman of flesh is related to the process of the Lady Archetype. And finally, we said that the western virya, in most cases, suffers such confusion that it is quite possible that he ignores his own "capacity to love" and thus also ignores when it is appropriate to follow the tantric way. In this case the conclusion of the Family Test is definitive because it will indicate if he should continue "loving" the woman of flesh or if he is already in conditions of A-mar to Kaly.

We already know what is expected of it; now we must know what the Family Test consists of. First of all, let us say that this Test is absolutely personal, since it aims at reinforcing the individuality of the virya; and therefore it must be practiced by each one in particular, whatever his family situation may be. From the virya who is "alone" in the world, to the one who is the offspring of a prolific family, all must start from the principle that the Proof is "only of interest to him", is "personal", "inner" and even "secret". Only under such conditions of intimacy and self-respect can the Test be faced with possibilities of success.

On the other hand, it must be made clear from the outset that the Family Test IS NOT MORALLY INSPIRED; that is, it neither saves nor condemns anyone. It only determines the degree of existing dependence with respect to the archetypal processes and makes it possible, in any case, to reduce such dependence. This clarification is valid because no one but the virya will be able to evaluate the result of HIS PERSONAL TEST; and if the result is negative, we want to anticipate that it will be of no use for him to deceive himself: through tantrism he will only find bitterness, and it is possible that he will ruin his health and that of his partner.

Let us now present the Family Test.

Every virya attempting this test should begin with a preliminary inquiry: What is my family? Aiming to know where his hyperborean lineage comes from. The Hyperborean Wisdom provides two laws that must be contemplated when giving the answer:

1st Law - The hyperborean inheritance of pure blood is transmitted maternally. This inheritance can easily annul the process of the family archetype of the maternal lineage. The answer to the inquiry into the family begins, then, first of all, with the maternal lineage.

2nd Law - The family Archetypes transmit their traits by genetic inheritance. If the mother's hyperborean inheritance is strong, the paternal genetic inheritance will predominate and, therefore, the family Archetype of the paternal lineage will dominate in the intensity of the process. But if the maternal hyperborean inheritance is weak, then the genetic inheritances of both parents are distributed, as Genetics points out. When inquiring about the family, according to the second law, the paternal lineage will appear in second place.

The inquiry, considering these two laws, should refer at first only to the relatives who have lived or live contemporaneously with one's own generation: especially the close relatives, those with whom one has lived and who have most strongly influenced or affected us. Secondly, after this determination, the inquiry will fall on the ancestors; BUT ONLY IF THE TEST OF FAMILY WITH CONTEMPORARY RELATIVES HAS BEEN MET.

When the inquiry has been answered and the relatives TO WHOM THE TEST IS TO BE REFERRED are well borne in mind, the test must be approached with the mind set upon the concept that each relative is indeed ANOTHER EXPRESSION of the family Archetype. If this simple truth has not been understood, or is not accepted, it is useless to attempt the test.

Once the preliminary inquiry has been completed, and bearing in mind the aforementioned concept, the Family Test can be carried out. THIS CONSISTS OF LOCATING THE EXTERNAL RELATIONSHIPS THAT LINK US TO OUR RELATIVES. One way of

To describe the operation of the Proof would be to say that it is a questioning of these external relations, but this is not entirely accurate; rather, it is a matter of DISPOSING THE MIND TO KNOW what the questioned relations are. If we are clear about what it is that we wish to know, the answer will immediately emerge in our consciousness, without the need to resort to reasoning or questions.

logical.

To be clear about "what we want to know" ... we can resort to the following concepts:

A - By "external relationship" we refer to those of an affective order ("sentimental" or "emotional"), being excluded in a first consideration those purely gnoseological relationships, which come from "knowing" that the genealogical tree is a factual fact. In other words: we all know what an uncle, a father, a brother, a sister or a cousin is; WE DO NOT REFER TO such structural relationships when considering OUR uncle, father, brother or cousin, but TO WHAT WE FEEL ABOUT THEM.

B. Every affective charge is obviously an "internal" content, proper to the psychic sphere. Why, then, do we call the affective relationship with relatives "external": because the existence of "affections" between relatives who share the same family archetype is purely illusory; and because the support of this illusion is rooted in the "external world". We must distinguish, then, between the "true" affections we feel for other people or things and the "external (affective) relationship" we believe we experience for our blood relatives. Let us explain how this confusion arises.

It is clear that every affective charge proceeds from a subject-object relation, established on the basis of the differentiations of the self. Through the effect of objectification, anything is susceptible of possessing an associated affective charge, which, in many cases, it will not be possible to separate from the thing itself. But the virya is normally inserted in a de facto cultural superstructure where he plays his dramatic role and from where he gathers his external experiences which, to a greater or lesser extent, constitute "internal" affective relations. If the object of attention is another person who also integrates the superstructure, the confrontation of one's own cultural structure and that of the neighbor produces a mutual affective relationship which is called "Karmic" because it is transferred from the personal collective unconscious to the universal collective unconscious, that is to say to the psychosphere, where it takes shape as RELATIONSHIP BETWEEN PSYCHOID ARCHETYPES and from where it CAUSES subsequent "Karmic" effects. In the drama of life a virya can love or hate another, or be loved or hated by him, and attribute to such affective relations the character of a concrete bond, since they are consistent and effective within the superstructure (if they "exist" their "existence" can be proved) and even generate future Karmic reactions. And that the relationship of hate or love with the neighbor constitutes a "concrete bond" cannot be denied, since it implies the weight of the affective charge on the consciousness, each time it refers to the neighbor.



Is it the same with blood relatives? It is usually believed that it does, but we will see that this is not so. In the first place, let us remember that all affection must be REFERRED TO AN AFFECTIVE OBJECT, to which it has been differentiated and with which a relationship has been established. But, relatives being expressions of the same family type, can they be considered affective objects in the same way as any person whom one loves or hates? The Hyperborean Wisdom affirms that a blood relative is an "object" to the same extent that the "I" is an "object" when it asks "what is the I?" and places itself as the object of its own interrogation. In that case, the "I" carries out a reflection, an unfolding of itself, in order to "observe" itself gnoseologically; but, however effective the objectification of itself may seem, the result of the inspection will always be subjective, impossible to verify by anyone other than the reflecting "I"; that is why we call the "object" produced by the reflection of the "I" upon itself "illusion". Now then: according to the Hyperborean Wisdom, the blood relatives are "reflections" of the family Archetype; and therefore, in that sense, the qualification of "illusions" also corresponds to them. In any case, it is the "affective and even cognitive relationship" that we believe exists between us and our blood relatives that should be rigorously described as "illusory".

C - Of course it is very difficult to transcend the barrier of this illusion, but no one said that going from "lost virya" to "awakened virya" was an easy task. And, we can be sure: whoever has not become independent of the evolutionary process of the family archetypes will find his strategic orientation very difficult. But such "independence" is not acquired by denying the problem, i.e., by rejecting or ignoring the structural function of the family, but simply by becoming aware of the situation and facing the Family Test.

The first obstacle to accepting that relatives ARE NOT true affective objects is the fact that these relatives actually appear as objects in the external world. And in the face of such a concrete presence, the assertion that these are mere illusions seems to be groundless. But the reality is this: our relatives, like ourselves, are true objects FOR THE NEIGHBOR; the relatives, BETWEEN THEMSELVES, are expressions of the same subject: the family Archetype; and none of them can be considered "objects" of the other, except in a "reflexive" capacity.

A second obstacle to accepting the illusory character of family objectivity comes from a phenomenon called "feedback by mutual capture". This phenomenon, characteristic in the evolutionary processes of family archetypes, is responsible for the belief in "external" (affective) relationships between

blood relatives. To understand their behavior let us recall what we said a few pages ago about the Manu Archetypes that support the superstructure of a cultural fact: "The cultural fact develops driven by a great power, WHETHER THE OBSERVER NOTICES IT OR NOT, and in this march towards entelechy the superstructure TAKES WHAT IS NECESSARY FOR ITS PERFECTION AND REJECTS WHAT IS NECESSARY FOR ITS PERFECTION AND REJECTS WHAT IS NOT NECESSARY FOR ITS PERFECTION AND REJECTS WHAT IS NOT NECESSARY FOR ITS PERFECTION. IS USELESS OR OPPOSITE". The family archetype proceeds in the same way, for, through the members of the "family", it tries to accommodate itself in the superstructure by occupying the places left free by the karmic relations and by adapting itself to the evolutionary processes of the Manu. It is thus that the relatives come to play a determined role in the drama of life, FROM WHICH THEY MUST NOT BE REMOVED, under penalty of being excluded from the superstructure (which would imply that the family archetype would cease to evolve through the "expelled" or disincarnated relatives). In order to fulfill their determined roles, the relatives do not have to suspect that they are all expressions of a single Archetype and, on the contrary, they must establish "external relations" with each other, often passionate and dramatic, as it suits the "Karmic directions" of the superstructures. In order to affirm the relatives in their roles, and to confirm the illusion of their objective and different existences, the family Archetype produces the phenomenon of feedback by mutual capture.

We already know how the "capture" takes place: when confronting one's own cultural structure with the superstructure, in order to "know", the psychoid Archetypes that support the external cultural objects MODIFY THE RELIEF of the same, enhancing the projection ON the external objects OF the interior cultural premises. Therefore, every cognitive act of an external object is in reality the RECOGNITION, or conscientization, of an interior object projected in the world. This is where the "capture" begins, for the exteriorization of interior objects implies participation in the evolutionary processes of the superstructure, their integration into the cultural fact. This effect is sought by the psychoid Archetypes in order to obtain the energy they use in their unfolding. In short: "the psychoid Archetypes FEED (take energy for their evolution) from the cultural structures (the viryas) that they manage to CAPTURE in the superstructure".

"Mutual capture" occurs when two relatives confront, within the dramatic framework of a superstructure, their cultural structures in order to gain reciprocal knowledge of themselves. Here the family archetype, which is psychoid, effects a double capture, since both relatives are expressions of their own evolutionary process. Let us suppose that the relatives are Mengano and his brother Perengano. Thingy looks at Perengano as a "cultural object" and projects on him an inner image; but it was the mutual family archetype that ADAPTED Perengano

to the other.

(as to the "little mirror" of the allegory) to RECEIVE THE PROJECTION made by Mengano; and it does it WITH KARMIC CRITERION, so that the "external relation" established between Mengano and Perengano adapts itself to the drama of life, that is: to the "Manu" process of the superstructure; Mengano RE-COGNIZES that it is HATE what he feels for Perengano: this relationship makes it possible that the greater power of an "object" (Perengano) integrated in the superstructure, "captures" the cultural structure (of Mengano) in the process of the psychoid Archetype that evolves in the "object"; produced by the capture, every Archetype feeds on the energy taken from the captured subject; but in this case, the Archetype that sustains the object (Perengano) also sustains the object (Mengano); and the energy that it takes from Mengano to develop the entelechy of Perengano is ITS OWN REALIZED ENERGY. If we consider that Perengano has also "looked" at Mengano as a "cultural object" and from that examination concludes that he experiences mercy, we can understand that, reciprocally, the family Archetype will feed energy from Perengano to the evolutionary process of Mengano. There has occurred, then, a phenomenon of "feedback by mutual capture", which has the purpose of creating between the relatives the illusion of external (affective) relations.

The process of the psychoid archetypes in the superstructure constitutes a drama for those who are subject to it and must play a role. And in this drama the blood relatives have to behave as if they really were particular individuals in order to ensure the development of the plot. That is why they ignore the fact that they are all one and believe that there are real emotional relationships between them.  
For

What is this hatred of Mengano and this pity of Perengano if not the illusion of the external affective bonds that the double capture causes? It is as if someone were to order his left hand to hit his right hand and a witness, seeing only the hands, were to affirm that the left hand "assaults" the right hand. The hands do not act separately, although appearances indicate the contrary, for they are part of the same organic structure and both obey the brain; in the same way that the relatives, although they may think they hate or love each other, do not act separately, for they are part of the same family superstructure and all "obey" the process of the family archetype.

D - We said that the Family Test "consists in locating the external relations that link us to our relatives" and, in the preceding comments, it was made clear that the "external relations" are the various affections that we have towards them and that such affections constitute an illusion. With these clarifications, and remembering that "interrogation", in our concept, does not refer to a logical construct but to a psychic disposition to "know", we can also say that: "the Family Test consists of answering the question: what do I feel for

my relative Albano?"

In the form of an interrogation, the Family Test may be more accessible to the Westerner, accustomed to thinking rationally, as long as it is remembered that the interrogation aims at ascertaining the existence of "external relations".

E - Taking into account what is stated in the 1st and 2nd Law, the family test can be faced by interrogating the relatives selected in the preliminary inquiry, that is to say, the contemporaries. The procedure of the test is as follows:

Question: How do I feel about Uncle Albano? Answer: "hate" or "love" or "affection", etc., or an indefinable sum of affections. It does not matter in principle the quality of the affection: IF THERE IS AN AFFECTION OF ANY TYPE IT MEANS THAT THE ARCHITECTIVE PROCESS HAS ILLUSORIOUSLY ESTABLISHED A KARMIC RELATIONSHIP. In that case the virya should not go ahead with tantrism and should be careful when undertaking the other hyperborean paths of liberation, for he is NOT YET READY TO INITIATE THE SEARCH FOR THE CENTER.

F - But from the analogy established between the "family" and the hydraulic network of the rivers, the conclusion was drawn that the stream Mengano can increase its flow until it approaches that of the Great Villano River, adding with its own the flows of the remaining tributary rivers. This conclusion was translated analogically by affirming that the virya Mengano will be able to purify his blood, to the degree of equaling his hyperborean ancestor Villano, to the extent that he succeeds in reintegrating in himself the family Archetype, whose pieces, in the form of blood relatives, are scattered throughout the world.

If it is possible to reintegrate the family archetype, it will be necessary to begin by eliminating that which constitutes the illusion of separation, that is to say: the "external relations". The Family Test will make it possible to locate the affective relationships with the relatives; RECIPROCAL IDENTIFICATION will make it possible to reduce them.

Before explaining how to reduce external relationships, we will offer a word of caution. We realize that it will be difficult for many viryas, who have relatives for whom they experience feelings of contempt or disgust, to accept that they are part of a single entity in which they are also included. If such is the case of the lost virya, who upon facing the Family Test discovers that a whole universe of passions binds him to his blood relatives, the Hyperborean Wisdom says to him that nothing prevents him from continuing to evolve within his blood relatives.

of the Plan of the Demiurge. If his passions bind him to illusion and he does not feel capable of overcoming them, it is useless for him to sharpen his ear, for he will never hear the song of the Siddhas, nor will his spirit come from the origin in the memory of blood. The Hyperborean Wisdom, on the other hand, does not urge the virya to cease to feel affection for his relatives but, on the contrary, advises him to accept the bitter reality that they are part of himself; and that it is a duty to reintegrate them into himself by "reciprocal identification". If this wonderful reintegration takes place, the relatives we love will no longer be outside but inside, where we will always be able to find them since they will not die like the external relatives who are a mere reflection of the family archetype. Of course, next to them will be the others, those for whom we do not profess positive affections; and also many, many ancestor relatives whom we do not remember but who represent ancient trials, evolutionary tests, involuted aspects of the family archetype.

G - The "reciprocal identification" is the method of affective reduction of the Family Test. Through the Test we locate, for example, certain affections towards Uncle Albanus. These affections create the illusion of Uncle Albanus' individuality and prevent his inner reintegration. To reduce them, it is only necessary to identify the external relationship that links Uncle Albanus with us, that is: a "reciprocal identification".

It is clear that this method is intended to cancel out feedback by mutual capture after reducing external relations between relatives.

We know, through the Proof, the affective relationship towards Uncle Albanus; reciprocally we must now inquire what is the affective relationship that Uncle Albanus has with us. For this we will have to practice empathy with Uncle Albanus, place ourselves in his place WITH RESPECT TO US, and experience, as if we were really Uncle Albanus, the feelings that he feels for us. Naturally it cannot be done without great effort (and no one said it would be easy); but it will have the remarkable effect of VOIDING our own external relations with Uncle Albanus. Of course, such empathy, which would be almost impossible to experience with a stranger to our lineage, is not so difficult between members of the same family superstructure. If the reciprocal identification is successful, if we have succeeded in "looking at ourselves from Uncle Albanus" and have identified the feelings that bind him to us, then we will see with admiration that when we look at Uncle Albanus again, OUR OWN AFFECTIONS TOWARDS HIM HAVE BEEN REDUCED, if not totally disappeared; and the illusion of separateness HAS CEASED. External relations have cancelled each other out.

But Uncle Albanus continues to live in the world: what will we see when we look at his face, now that the mutual external (affective) relations have disappeared? will we suffer again the capture in the cultural structure of Uncle Albanus? Capture will not occur again because there is no difference between outer Uncle Albanus and inner Uncle Albanus, or, if you will, there is archetypal identity between us and him. After the Family Test, when we look at the face of the reintegrated relatives, as in a mirror, we will recognize in them aspects of ourselves; profiles ignored until then but which we will undeniably know how to find in ourselves.

H. It is only when the virya has reintegrated a considerable portion of the familiar archetype that it can be said, allegorically, that he has increased the flow of his pure blood. The way to mutation is now open; for as the illusion of the "thousand familiar faces" is diluted, the Karmic chains also cease. The process of the family archetype points toward the future; therein lies its entelechy. On the other hand, the inverse path of reintegration, just mentioned, is equivalent to inverting the process and marching towards the Great Hyperborean Ancestor, the one who KNOWS THE SECRET OF THE FALL BECAUSE HE HAS BEEN THE PROTAGONIST; who is also the one who has been the protagonist in the process of the fall.

is called: The Great Deceiver. Sooner or later, the virya who follows the path of pure blood will have to confront him. And from that supreme confrontation will emerge the Primordial Truth. Then the virya, like a volcano of emotion, spilled in a cascade of millenary passions, will throw himself at his feet to remove the chains of Deceit, the crickets of Betrayal, and will restore in himself the extraterrestrial lineage of the Hyperborean Siddhas.

The Hyperborean Wisdom says:

*"Always remember that your family is both tree and river. That is why it is said that the Great Ancestor is 'in the roots of pure blood'. There you must look for him, going backwards up the current of the ancestral river or down some branches that are also hieratic faces, mirrors of yourself. He is waiting for you, always; for your arrival means his liberation. But be careful how you present yourself to him. Lest His face terrify you and you shrink back foolishly. Remember that He is there because He has fallen; and therefore His face shows the ravages of ancient and terrible passions. O Virya! He can only be liberated if you look at Him and hold His gaze! But that gaze will mean your death! O Virya, nothing will be hidden from you, now that you know the secret of the tree and the river: yes, at the sight of Him you will die; but you will rise in Him when, freed, HE TURNS HIS FACE TOWARDS THE ORIGIN! For behind the back of the Great An- tepassed One lies the primordial origin, to which, BY A MYSTERY OF LOVE, He was deprived of returning*

**Nimrod from  
Rosario**

**395**

*since the Time of Pain and Suffering began. Dead and reborn: in resurrecting you, you resurrect the Great Ancestor, and there remains the Great Ancestor, the Great Ancestor.*



*welded the sword that was broken in the origins; you and The Great Ancestor become one again, as you always were without knowing it; and that is why, marching towards the origin, dead and reborn, you are an Initiate of the Pure Blood, a Knight of the Grail, an Immortal Siddha, a Divine Hyperborean, a Warrior of Lucifer The Gallant Lord.*

*A great secret you know, O Virya: that of the tree and the familiar river; if you are fearless and bold, but also humble and detached, and not afraid to CHECK YOUR OWN MISERY, then this great secret will lead you to Vrill!"*

In the eight preceding commentaries we have exposed the Family Test that makes it possible in an infallible way for the western virya to establish "when" he can "safely" resort to the sexual techniques of tantrism. We have already stated "when" it is NOT TO DO SO: when there are EXTERNAL RELATIONSHIPS with blood relatives. But someone may ask: what do affective relationships between relatives have to do with the sexual practices that we will perform with our partner? Whoever asks this question surely forgets that the exoteric objective of all yoga, and also of Tantra, is to "awaken Kundalini" and that Kundalini, as Logos, has the power to "recreate" the bodies of the virya. Only he can aspire to mutation who, like Wildejäger, is ready for everything and nothing binds him to the work of the Demiurge. But if there are external relations with the relatives, it means that the virya is karmically bound and plays a role in the drama of life; and, what is worse, his body constitutes only a part of the family archetype. And no one can immortalize "a part" of the microcosm.

When Kundalini awakens, HER VERB IS DESCRIBING THE FAMILY ARCHETYPE AND FIXING ITS PARTS; if the virya has his relatives "outside", then Kundalini will only recreate "as far as consciousness reaches" and fix that part of the family Archetype which the virya believes himself to be. This result is inevitable because Kundalini, as a reflection of the Aspect-Logos of the Demiurge, has the "secret mission" of harmonizing the microcosm with the macrocosm, man with the Plan, and WILL NEVER ALTER BY ITSELF A KARMIC RELATIONSHIP such as that implied by the external relations with the relatives. The consequences of the awakening of Kundalini vary considerably, according to the degree of confusion of the lost virya; they range from a "benign" fusion with the Demiurge in the sahasrara samadhi to the annihilation of the physical body "by decision" of the family Archetype, who will try to evolve through the other relatives. This last possibility will cause surprise because, naturally, one always thinks that he is "the best" or most evolved of the family; BUT THE FAMILY ARCHETYPE MAY NOT BE OF THE SAME OPINION. In any case,

Kundalini will always conduct herself according to her secret directive to "harmonize" (recreating the microcosm) and "fix" (the recreated) to maintain or re-establish the synchronism of the rhythms of the microcosm with the Plan of the



For the virya, the reintegration of the family Archetype, by the Family Test or by any other procedure, is indispensable BEFORE awakening Kun-dalini. But, it will be said, are we then going to realize in ourselves the entelechy of the family Archetype? No, because all that we have said about Kundalini refers to her "left to her secret directive"; and we have said nothing yet about the manner in which one should proceed with the Igneous Word DURING tantric practices. The purpose of "awakening Kundalini" is only a tactical action, a means to achieve the strategic objective of the return to the origin, as the Hyperborean Wisdom teaches every virya sadhaka.

We have already stated "when" tantrism should not be practiced: when there are external relations with the relatives and the virya is bound to the process of the family Archetype (and to the processes of the psychoid Archetypes of the superstructures). And we explain why: the family Archetype must be reintegrated in order to prevent Kundalini from recreating only a part of it. But this is only one aspect of the difficulty; and, if you will, the minor one. The greater problem is the fact that "he who suffers from the illusion of external relations CANNOT DISTINGUISH KALY". And the perception of Kaly is necessary A PRIORI of the tantric praxis because it constitutes the foundation of the hyperborean restoration that must be carried out in the nature of the microcosm to achieve its transmutation.

The Hyperborean Wisdom teaches, on the other hand, that "KALY LOVES ONLY ONE WHO IS COMPLETE AND IS ONE IN HIMSELF". We will soon see the importance of this statement.

There is a third aspect of the difficulty (to orient oneself) of suffering from external relations, which is the following: the virya who loves or hates his relatives is prone to "love with the heart the woman of flesh", that is to say, to contribute to the process of the Lady Archetype. This propensity comes fundamentally from the Karmic relations, which determine the TYPO of the "destined" couple; from the blood confusion which has caused the "forgetting" of the hyperborean woman; and from the "splitting" of the family Archetype, which prevents "distinguishing Kaly".

So far we have reviewed in some depth "when" one should not practice tantrism. Let us now see "when" it is possible to do so, and also, a question that was pending, what for?

Let us suppose that the virya Mengano has succeeded in reintegrating in himself the family Archetype, eliminating by reciprocal identification the "external

**Nimrod from**  
**Rosario**  
relations", that is to say,

to the illusory affections that kept the kin "out". He has done this, but he has not yet gone back up the stream of pure blood to reach the Great Ancestor. He knows he must do this quickly for, being "complete," the family Archetype will accelerate his evolutionary process to realize his entelechy. To be "complete" means to have untied the karmic bonds, a situation that the family archetype will only allow if it can continue to evolve; otherwise, it will resort to the Devas of Death to get rid of the uncontrolled virya side.

Mengano knows this risk, but he has chosen the tantric way of the left hand to march towards the origin and therefore he sets out to fulfill the "Ritual of the Five Challenges". Mengano is a Western virya; his way of proceeding is inspired by the Hyperborean Wisdom; therefore, although undoubtedly tantric, his acts are conducted according to a symbology older than that of the Kaula School, but adapted to the circumstances of the West and its relationship with the End of the Kaly Yuga. There is a concept of the Hyperborean Wisdom that we will later develop in detail, but which is worth mentioning now because it justifies this apparent departure from Tantric orthodoxy; and it also explains the difficulties that the viryas of the West have in professing Eastern philosophies: it is that of GEOCHRONY. Geochrony is the property of the Earth to influence the Historical Time of the people who inhabit certain places. Thus it turns out that not all human communities are in the same relationship with respect to the Kaly Yuga, but that India, for example, is "further away" from the End of the Kaly Age than Europe. There is a whole "path of the Kaly Yuga" which begins at the South Pole and ends at the North Pole, but which winds around the planet following certain tectonic lines; and to this path we refer when we say, for example, "in the 4th century the Germans advance towards the Kaly Yuga", etc. The important thing now is to keep in mind that the Tantra of India and Tibet, the Kaula, and even the Kula path, have lagged behind the "geochronological index" of the West because the West is closer to the end of the Kaly Yuga than the East. That is why in the 20th century the Thulegesellschaft developed its own tantric yoga, which was used internally in the initiations of the Black Order SS. The concepts that we have been offering, and those that we will give in relation to the supposed "ritual" of Mengano, come from that western yoga of the Thulegesellschaft and from the Hyperborean Wisdom. We have preferred to avoid references to the Hindu Tantra because we would get lost in clarifications and commentaries; since the Orientals, today, do not see with clarity concepts as elementary as this: if the Kula path, according to the Tantras, is the search for an "absolute gnosis", we ask: how can they believe that the Demiurge Brahma, with whom they propose the fusion of Samadhi, is going to allow it without punishment? Westerners, on the other hand, have known for a long time that the search for knowledge, gnosis, is

This has been expressed in the myth of Prometheus or in the myth of the "fall of Adam", by the Alexandrian Gnostics, etc. There is a great confusion in current tantrism and that is why it appears tinged with devotion and ritualism, which disfigures the luciferic and warrior sense that it should exhibit in its character of hyperborean way of liberation for the Kaly Yuga. We will follow another path: we will walk on a bridge that saves part of the confusion because it is based on the purity of the Ancient Wisdom, on the one hand, and on the other hand on the concrete reality that a western virya, Mengano, for example, must face on a daily basis.

The Ritual of the Five Challenges consists of drinking wine, eating meat, fish and wheat germ, and practicing coitus or maithuna<sup>1</sup>. In each of these acts the sadhaka challenges the Demiurge; in the first four symbolically, and in the last one concretely. Before performing each of the five Challenges, one should meditate on its symbolism so that the Ritual represents a true ACT OF INDIVIDUAL WAR. It is worth repeating again that this final stage of tantrism should only be attempted when a previous training of organic control by means of yoga has been carried out and a very strong strengthening of the will has been achieved by the detachment and repugnance that the gnostic experiences towards the work of the Demiurge. When the virya is "ready for anything" and exhibits an unwavering warrior resolve, he CAN then face the Family Test to reunite the pieces of his soul that are scattered in the world. If he succeeds in this Test, and succeeds in reintegrating the Family Archetype within himself, he will then have arrived at the gates of the Mystery of Love. Let us say that it is perfectly possible to AVOID the confrontation with this Mystery and seek liberation by another hyperborean way. But if the virya possesses ABSOLUTE VALUE AND FEELS CAPABLE OF RECOVERING HIMSELF, perhaps he will dare, like Mengano, to practice the Ritual of the Five Challenges. Because this Ritual has the objective of TRANSMUTATING the body of the sadhaka AFTER HAVING COMPLETED THE REINTEGRATION INITIATED IN THE FAMILY TEST, INCORPORATING THE SYMBOLS INTO THE MICROCOSM. OF THE PRIMORDIAL BETRAYAL. The meaning of the Ritual is, then, to INCORPORATE THE SYMBOL THAT REPRESENTS EACH CHALLENGE; that is why the most important is recommended.

---

1 *The Oriental Ritual of "the Five M's" proposes to use the same elements and gives, for them, the following symbolic interpretation: the WINE (MADYA) represents the AIR; the MEAT (MAMSA) the FIRE; the FISH (MATIA) the WATER; the CEREAL (CEREAL) the WATER; the WINE (MADYA) the WATER; the WINE (MADYA) the WATER; and the MEAT (MAMSA) the FIRE; the FISH (MATIA) the WATER. (MUDRA) to the EARTH; and the COITUS with the WOMAN (MAITHUNA) to the*

*ETHER or quintessence. Naturally, such meanings are exoteric and are of no importance in the Ritual of the Five Challenges that we describe here, although it could have it in previous preparatory stages, especially if the virya follows in parallel an alchemical path.*

concentration while practicing it and, above all, not to experience sensual desires or pleasures during its execution.

Wine is the symbol of pure blood, and of the hyperborean memory of the origin, "THROWN" INTO THE WORLD BY THE PRIMORDIAL BETRAYAL OF THE SIDDHAS. Because of her Lucifer, the Christ of Atlantis, consummates the sacrifice of the infernal descent. But His sacrifice was parodied by Jesus Christ, who gave the wine the meaning of "plebeian blood", of pasu, which must be transmuted "outside" to transform it into "blood of Jesus Christ", that is: in Jewish blood. The first challenge is, then, to drink the wine; that is: to incorporate the pure blood that was spilled in the world, to transmute it "inside", in the microcosm, restoring the sense of the luciferic sacrifice.

Animal flesh alludes to the greatest Mystery that exists, AFTER the Mystery of Love. However, the Hyperborean Wisdom advises the virya not to inquire into this Mystery until he has achieved the liberation of transmuting into Siddha, so as not to add more horror to the horror of being chained to matter. This Mystery can be summarized as follows: just as the Hyperborean Spirits were chained to the evolution of the pasu, millions of years ago, a very long time ago, in periods measured in manvantaras and Kalpas, OTHER STEMS of immortal Spirits were chained to matter. No one knows from whence they came, whether they were created by the Unknowable or whether they fell from an unimaginable order; what is certain is that they too are prisoners of the Demiurge The One who has chained them to evolutions infinitely more primitive than those which the Hyperboreans of Earth must suffer. Just as the Hyperboreans are used "to produce culture," as explained elsewhere, so those spirits are used to "produce life," animal and vegetable, although they are often projected into the mineral "kingdom. And just as the Hyperboreans were linked to the evolution of the Pasu so that, from the struggle between the Hyperborean Spirit and the Pasu soul, culture could emerge, so also those strains of captive Spirits were linked to the entities of the devic evolution, to obtain the emergence of a new support of the material forms: life. When we say that those Spirits are linked to life, we mean only that: "life", the "fact of living", and it should not be believed that the group souls linked to the "higher" evolutions of the vegetable and animal kingdoms are an expression of the captive Spirits; such group souls, as their name indicates, belong to the devic evolution ("elementals" or Devas) and are in every way similar to the "soul" of the pasu.

Nowhere else outside the human sphere can the dramatic character of life be ascertained as in the animal kingdom: in its insurmountable stupidity, in the determination of its instincts, in the horror of the struggle for survival that leads



them to devour one another, in the fatality of their death, and so on. It is undoubtedly in the

Man, in order to endure the vision of horror that is life in the world, has created a cultural veil called "poetry" which, for example, where a miserable life that constantly eats and defecates is encouraged, makes us see a "beautiful singing bird". Poetry masks the horror of life and that is why it is the greatest enemy of gnosis. This affirmation may hurt but it is rigorously true; for much of the madness with which gnostic ecstasies usually conclude, comes from an insufficient preparation to resist the horrifying visions to which the work of the Demiurge is reduced when gnosis unveils the poetic veil and dissipates the illusion of aesthetic beauty (which is a pure cultural creation).

HE WHO DOES NOT POSSESS A Gnostic VISION OF LIFE WILL NOT BE ABLE TO UNDERSTAND THE MYSTERY OF DEATH. AND ATTENTION: WHOEVER DOES NOT PREVIOUSLY UNDERSTAND THE MYSTERY OF DEATH, WILL NOT BE ABLE TO ACCESS IMMORTALITY.

This is the knowledge that must be meditated upon before posing the Challenge of eating animal flesh. The meaning of the Challenge is the following: in the meat is present the Mystery of Life and Death (this must be understood) and Concrete Death; by eating the meat one incorporates the symbol of death into the microcosm and prepares the body for immortality. IMMORTALITY IMPLIES THE INNER RESURRECTION OF THE ANIMAL SACRIFICED OUTSIDE. AND, WHEN THE SYMBOL OF DEATH HAS BEEN NEUTRALIZED BY THE MANTRA OF LIFE, THE VIRYA'S BODY OF CORRUPTIBLE MATTER IS TRANSMUTED INTO VRAJA, INCORRUPTIBLE MATTER.

The fish symbolizes the terrestrial race of the pasu: from its origin in dark and ancient pools<sup>1</sup> to its end in the entelechy of the Hebrew Archetype Jesus-Christ, the whole history of the pasu is written in the fish. Eating the fish incorporates into the microcosm a symbol that is an expression of the Manu Archetype and that has the mission of "fixing" from within the limits of the family Archetype. The meaning of this Challenge must be meditated upon and understood in the terms in which it is presented here, since the symbolism of the fish is extremely complex and can give rise to intellectual deviations. We will only note that the first of the ten manifestations of Vishnu is AS A FISH (MATSYA-AVATARA) and that the Manu of this man-vantara, VRISVASVATA, has always borne the sign of the fish both in the Vedas, where he received this name, and in Mesopotamia, where he was called OANNES, or

---

1 *In truth, the pasu monad "was a fish" in the lunar chain and not on Earth, in a globe that later split into four to form as many moons, of which the present one is the last one that still remains as a terrestrial satellite.*

DAGON, or during the Roman Empire when he was reincarnated as IKHTHYS (Fish) into the Hebrew Jesus, etc.

The wheat germ represents THE WORD OF THE DEMIURG, the concrete expression of his Word. In the germ, as in any other BIJA, there is a potency that tries to unfold at the impulse of the Great Breath; therefore the germ must be considered as the symbol of the psychoid Archetype AT THE BEGINNING OF EVOLUTION. If the germ is placed in a FERTILE ENVIRONMENT, the Archetype will complete its process, which begins in germination and ends in the production of new germs or "reproduction". But all these qualities, which the plant acquires during the process of its growth, were already in potency in the original germ or BIJA. If the germ is kept in a bowl, in contact with air or VAYU TATTVA it does not germinate; but if it is deposited in the earth or PRITHIVI TATTVA, then it germinates and actualizes in the evolutionary process the various potential qualities. This symbol has special importance in interpreting "the awakening of Kundalini" who, like the germ, is a BIJA or "Word of the Demiurge", of particular potential content. But Kundalini is in itself A BIJA THAT EXPRESSES ALL THE OTHER BIJAS; A WORD THAT CONTAINS ALL WORDS; A SOUND THAT IS THE SYNTHESIS OF ALL SOUNDS, FOR IT REPRESENTS, IN THE MICROCOSMOS, THE AKASA TATTVA or "first ether" of the Great Breath. Like the wheat germ, Kundalini needs a "fertile environment" to INITIATE ITS DEPLOYMENT.

We have already said that Kundalini "awakens" by itself when disynchronizations occur between the microcosm and the macrocosm and we explained that its "secret mission" is to restore such alterations by harmonizing the totality of the rhythms of the biological process. We can now add that such behavior is due to the fact that KUNDALINI IS SENSITIVE TO THE COSMIC FLOW OF THE GREAT BREATH. If one

If you imagine AKASA TATTVA as an ocean of psychic substance and in the middle of it a bubble, you will have an accurate idea about Kundalini. In man, above the muladhara chakra, is the bubble of AKASA, inside of which "Kundalini sleeps". This bubble, like the germ exposed to the air, does not "unfold" unless its environment is altered, making it fertile. But the bija Kundalini is a bubble that floats in the AKASA contracting or expanding in rhythm with the flow of the Breath; only a variation in this flow can cause Kundalini to unwind and attempt to restore the solidary movement. AKASA possesses the dimensions TIME AND SPACE and, therefore, by altering these dimensions it is possible to "awaken Kundalini": this is the principle employed in the Hyperborean Strategy. In the Universe there are four states of subtle matter produced by the Great Breath: PRANA, coming from the Sun; MANAS, coming from Manu; VIONANA, coming from the Demiurge Jehovah-Satan; and ANANDA, coming from the Demiurge The One. The

operation with these matters also allows the awakening of Kundalini if its flow is altered: this is the principle used in the Synarchic Strategy, especially the control of solar prana by rhythmic breathing taught by the secular schools of yoga.

Kundalini is the seed of a plant with many flowers; its germination has the virtue of reproducing the process of the Universe because, when the bubble breaks, the original bija decomposes into all the Words of creation, thus recreating, in the microcosm, the order of the macrocosm. But this seed is hidden in man, who also does not know the content of its potency, the entelechy of its Archetypes. That is why, upon knowing the germ, the sadhaka incorporates this symbol into the microcosm, duly conscientialized, and poses the Challenge of determining by his will the germination AND the FRUITS of the plant. This may not be understood for, it will be said, "it is acceptable that by choosing the moment to give a "fertile environment" the germination can be determined, but how can the fruits be determined if they are POTENTIALLY CONTAINED IN THE Sprout?" If such is the doubt, think that a pumpkin growing inside a cubic form will not be spherical but cubic, for THE FORM DETERMINES THE BEING.

When Kundalini awakens by herself, or by a "synarchic call", she recreates "the form" of the family Archetype and those are "its fruits". In the Challenge we are considering, Kundalini is forced to awaken (germinate) WITHIN A HORMA that determines its form: that horma is the image of the Great Hyperborean Ancestor, with whose "form" the microcosm will be recreated.

The fifth Challenge consists in incorporating into the microcosm the symbol of the "hyperborean woman", that is to say, the image of Lillith; and by means of the maithuna or sexual act "outside", to marry her "inside". The success of this challenge, in which the other four become effective, means that absolute individuation and immortality have been achieved. But, as its approach requires the contest of the woman "outside", it will be necessary to clarify again that the yogini CANNOT BE ANY WOMAN, and much less a "beloved woman", or one for whom the least affection is experienced. The Kaula tantra, and all the "left hand" Tantras, are based on the worship of Shakti, the feminine or active principle of the Demiurge, who is considered as the "wife" of Shiva. We have already warned that the identification of Parvati with Shakti constitutes an error; we will now explain the nature of this error and how to avoid it.

At the beginning of a cycle, when the Pralaya or Night of Parabrahman concludes, the Demiurge is still unmanifested, sunk in the cosmic Abyss; there is unity there.

absolute. When the "awakening" of the One, its Manifestation, takes place, an evolutionary unfolding occurs which reaches the matter of the whole Universe by the impulse of the Breath; this unfolding, from which the akasa "comes out", is the "model", the "mother" of all the evolutionary processes of the Universe. During the Manifestation, the Demiurge expresses himself in infinite pairs of opposites that make it almost impossible to notice the previous unity. But this is only an illusion, maya; the unity has not been split, for it remains behind the veil of duality, as the Gnostics who manage to reconcile the opposites in the microcosm and transcend toward the one Principle know very well. It is therefore useless to discuss the duality or unity of the Demiurge, both concepts being the expression of different "moments" of his behavior; that is to say, different "phases" of his cycles of Manifestation, of his "nights" and "days. But when it is necessary to take into account the evolutionary aspect of matter and its different organizations, the reference to the opposites and their essential duality is inevitable. Then, for the sake of simplicity, and without forgetting that we are dealing with "a second state" in the nature of the Demiurge, we speak of great opposite principles: yin and yang; good and evil; masculine and feminine; etc. Religious systems derived from such considerations, like all that is religious, imply a Gnostic degradation, an exoteric fall, especially if the opposites have been personified and give rise to devotion on the part of priests and faithful. For example, the three pairs of opposite principles that we have mentioned give rise, respectively, to the religions of Taoism, Zoroastrianism and Hinduism; and in all three, knowledge appears emotionally tinged by the mythical reduction to which the principles have been subjected and by the devotion that all worship implies. The path of the Gnostic, on the contrary, consists in avoiding devotion and leaping towards the principles, establishing a transcendent contact with the unity in which the multiple dualities are resolved. But such contact does not come about by way of "fusion with the One" or by any kind of identification with the Demiurge, but by understanding the inner unity of the microcosm in which the macrocosm is reflected. This comprehension is a pure knowledge, a gnosis, which enables the virya, after infinite horror, to overcome the Manifestation and to reconstruct the unity of the Demiurge and thus, in a vision of madness, to verify his folly and intrinsic malignity; however, after the horror, there comes the uncovering of the True God, HE WHOM IT IS NOT POSSIBLE TO KNOW FROM THE ABYSS. All gnosis ends there, in the certainty of the Unknowable, Whom IT IS NOT POSSIBLE TO TRANSCEND BY KNOWLEDGE AND, THEREFORE, IT IS NECESSARY TO CREATE HIM. WITH THE POWER OF THE SPIRIT. The Vril provides this absolute possibility.

Duality is, then, a mere appearance; but an extremely consistent appearance as long as one does not attain the definitive gnosis that allows one to transcend it. In the confused state of "lost virya", or during the transition to the state of "lost virya", one starts from a differentiated perception of reality and its decomposition.

rational division into pairs of opposites. This leads to the concept that Manifestation is based on a primordial dualism which, in Hinduism, is personified in the male figure of a God and the female figure of his "wife" or Shakti. Analogically reduced in this way, the Supreme Principles can be reconciled "in the marriage" of the Gods, merging into the original unity or "begetting" other manifestations also dual. But, in the myths in which the Principles are feminine and masculine, one must see the cultural shaping action of the hyperborean spirits combined with the rational-emotional mechanics of the animal-man or pasu. Shiva and Parvati are just that: cultural images produced by the hyperborean "blood-memory" adapted to represent the Supreme Principles by the rationality of the pasu. Shiva is the remembrance of the Gallant Lord, Lucifer. His wife Parvati can be none other than the extraterrestrial partner of Lucifer: Lillith.

Tantrism, which is, as has been said, a Gnostic system, has fallen exoterically after the interpretation of its secret texts by the dualists of Buddhism. They, who propose fusion with the One, identify in the microcosm SHIVA WITH THE FAMILY ARCHETYPE, AND PARVATI WITH THE SHAKTI, THAT IS TO SAY WITH KUNDALINI. In this interpretation, the "awakening of Kundalini" and its ascent to the ajna chakra, means "the marriage of Shiva and Shakti". But, as it is easy to deduce after all that has been said about the family Archetype and Kundalini, this "marriage" is nothing more than the recreation of the microcosm in harmony with the macrocosm and the definitive subjection to the Plan of Evolution, that is to say, to the process of the Manu Archetype.

This is not precisely the goal of gnosis. In order to avoid nirvana and to concretize the end of absolute individuation, it is necessary to reestablish the ancient esoteric meaning of the tantric symbols. Only in this way will it be possible to understand the ritual of the Five Challenges.

For the sadhaka Mengano, the recreation of the family archetype as a model of the microcosm, by Kundalini, constitutes a catastrophe. On the contrary, he will seek to IDENTIFY HIMSELF WITH THE GREAT HYPERBorean ANTEPAST, IN THE CULMINATING MOMENT OF THE MAITHUNA, IN ORDER TO IMMORTALIZE WITH ITS FORM THE MICROCOSM. COSMOS. And this hyperborean restoration is the declared aim of the fifth Desafío; let us see how it is to be achieved.

We said that Kundalini "sleeps" in a bubble of Akasa, above the muladhara chakra. That bubble is, in symbolic language, the primordial egg containing the germ, the seed, of the potential, undifferentiated Shakti. Kundalini Shakti is a reflection in the microcosm of the first bija pronounced by the Demiurge at the

beginning of the Manifestation and its consequent separation into pairs of opposites. That is why we say

that she is the Word; the shaping Logos that recreates the Plan; Bija of bijas, Word of words. But if she, as Logos, possesses the principle of all forms, what is her own form, prior and first, ontological and ontic synthesis of all that exists, Form of forms? It is necessary to answer this question BEFORE BREAKING THE SHAKTI EGG; for if not, as happened when Pandora's box was uncovered, countless evils may befall the ignorant man.

We note in passing that the lack of answer to the above question, or ignorance, is the cause of what we have called "awakening of Kundalini by its own means"; for, although this "awakening" is achieved by means of yoga, if one neglects the formal knowledge of the bija Kundalini, one will inevitably lose all control over its plasmatic power and end up succumbing to nirvana. The Gnostic does not seek to annihilate his self and does not renounce action; on the contrary, he STRENGTHENS HIS SELF BY STRATEGICALLY DIRECTING THE WILL TO ACT. THEREFORE, IN THE GNOSTIC, IT IS THE "I" THAT AWAKENS KUNDALINI BY DETERMINING HER FORM. We are not talking about the essence, which is "feminine" and actively manifests as Logos; but about the FORM that, as Shakti, Kundalini will adopt during her manifestation.

If the previous question is ignored, which happens in the synarchic schools of yoga, then Kundalini, upon awakening by its own means, TAKES THE FORM OF THE PRIMORDIAL MOTHER, WHOSE ARCHETYPE "READS" IN THE GENETIC MEMORY. OF THE PASU. The idea of the feminine principle as "mother" is linked to the separation by sexes of the androgynous animal, ancestor of the pasu. Certainly such an idea HAS NOTHING TO DO WITH HYPERBORIC WISDOM; for the captive spirits HAVE NO MOTHER; and their sexes, as stated elsewhere, are not related to a reproductive function.

TO LEAVE KUNDALINI FREE TO HER OWN FORM IS TO ALLOW PARVATI TO BE IDENTIFIED WITH SHAKTI, THE "WIFE" WITH THE "COSMIC MOTHER"; IT MEANS THE RECREATION, THE "REBIRTH" IN THE MICROCOSM, OF THE MANU ARCHETYPE, ITS ENTELECHY; AND, CONSEQUENTLY: THE DEFEAT OF THE SPIRIT IN ITS PRETENSION TO TRANSIT INVERSELY TOWARDS THE ORIGIN.

There are many viryas who, instead of the desired liberation from material enchainment, end up even deeper in matter due to an incorrect and exoteric practice of yoga. And in this result has much to do with the pretended DEVOTION OR WORSHIP that is demanded towards the Shakti. This emotional attitude is called "strategic disguarnition"; for the awakening of Kundalini "as ma- dre" surprises the virya in a state of total helplessness, "adoration", and leads to



to succumb to the process of the Manu Archetype.

Let us see what the esoteric procedure must be for the fifth Tantric Challenge to culminate with the spiritual liberation of the virya: IT IS THE SELF WHO PLASTS THE PRIMARY FORM OF THE PLASMING LOGOS. This is achieved by projecting upon the egg THE FORM OF LILLITH, who is not the "mother" but the spiritual wife of Lucifer and the general prototype of the hyperborean woman.

It should be expressly clarified, in order to dispel any error, that Lillith IS NOT AN ARCHETIPO but a hyperborean "blood memory".

The problem, in order to accomplish such an operation, is the following: how a lost virya, who has not yet succeeded in perceiving his Minne, can "project" the image of Lillith, which he has certainly "forgotten" because of the blood confusion? It is precisely for this that the maithuna is established, the sexual act with the "woman outside": SO THAT THE IMAGE OF LILLITH EMERGES FROM HER AND IS INTRODUCED "INSIDE", RECOGNIZED BY THE "I", WHO IN TURN WILL PROJECT IT ON THE EGG, AWAKENING AND SHAPING THE FORM OF THE HYPERBOREAN WOMAN IN KUNDALINI, THUS RECOVERING "INSIDE" THE WIFE OF THE GREAT ANCESTOR.

And here comes the terrible demand, the fundamental key to the Mystery of Love, without which no tantric practice makes any hyperborean sense: THE WOMAN OUTSIDE, THE YOGINI, CANNOT BE JUST ANY WOMAN. SHE MUST BE A KALY WOMAN!

We previously demanded "not to love with the heart the woman of flesh"; now we know that, in addition to "not being loved", the external woman must be "Kaly". There are, then, two kinds of women: the "Eve woman" or "woman of flesh" (pasu woman) and the "Kaly woman". To establish clearly the difference between both types of woman, we must start from the following concept: after the fall into matter, by a Mystery of Love, the tragedy of the incarnation and the slavery of the Hyperborean Spirit has taken place; in the drama of life, by its sanguine confusion, but mainly by the Mystery of Love itself, the virya HAS FORGOTTEN THE FACE OF HER HYPERBOREAN COMPANION, whom, generically, we call: "Lillith". This forgetfulness can only be qualified as "PRIMORDIAL MADNESS"; and, although some ways of liberation allow the virya to travel the inverse path in solitude, tantrism, on the contrary, demands THE PRIOR REMEMBRANCE OF THE FACE OF THE PROMISED ONE TO PLASTER, WITH HER FORM, THE EGG OF KUNDALINI SHAKTI. The problem consists, then, in GIVING A FACE TO LILLITH, a supreme experience that means: TO BE

**Nimrod from**

**Rosario**

FULFILLED AGAIN, AFTER MILLIONS OF YEARS OF INFAMY, THE DIVINE

**413**

## FACE OF THE HYPERBOREAN WOMAN.

It must be understood that we are before a fundamental Mystery of the human drama, and that it can only be "sketched" literarily, "insinuated" through symbols and clues. For we shall now explain the difference between the woman Eve and the woman Kaly; but such an explanation will always be insufficient unless we can pierce the veil of symbols in a gnostic way. The problem, "to give a face to Lillith", can be posed in this way: if the virya has forgotten "inside" the face of his betrothed: can he perhaps find it "outside", "projecting" for example the "forgotten" face, that is: unconscious, on a woman of flesh? Yes; such a possibility exists; but, we repeat, THE EXTERIOR WOMAN, THE YOGINI, CANNOT BE ANY WOMAN. And we add: the Kaly woman IS THAT WHICH RE-SEALS, UN-CLOUDS THE FORGOTTEN FACE FOR ITS OUTSIDE CONTEMPLATION. Why Kaly?: because Lillith "outside" is Kaly ...

It is necessary that we take a few turns around this Mystery. At first we must make a distinction: the "projection" of Lillith IS NOT LIKE THE PROJECTION OF AN ARCHETYPE, FOR SHE IS A BLOOD REMEMBRANCE. Which one?

The difference is: that every Archetype of the microcosm is reflected in Archetypes of the macrocosm, and therefore: THE PROJECTION OF AN UNCONSCIOUS ARCHETYPE, FROM "INSIDE", DOES NOT SUFFER DEFORMATION "OUTSIDE". But the memory of

Hyperborean blood has no symbolic equivalences in the macrocosm; and thus its projection is NOT FORMED BUT CON-FORMED, COM-POSED, from the "archetypal quanta of energy" (U.E.V.A.C.) involved in the reflecting matter. There is thus an important deformation when the blood memory is seen "outside", in the world of Maya, the "illusion". In the case of the Beautiful Face of Lillith, we must assume that the deformation is atrocious; since the same, "outside", has been transformed into the fierce image of Kaly "The Black". But the lost virya has no other alternative, if he has committed the folly of forgetting The Beautiful Face, but to discover it, to find it again in the world, transformed INTO A TERRIBLE DEITY ... AND TO LOVE HIM SO.

Kaly is an image of madness, for it has been madness to forget Lillith. The Western sad- haka, in seeking Kaly in the world, is faced with the madness of contemplating his black face and attending his frenzied dance; hence the Hyperborean Wisdom advises not to pose the fifth Challenge unless one is willing to LOVE KALY. But here by "love" is meant something different from the courtly love we have already defined above. To love Kaly means to TRANSMUTE THE HATE OF THE WOMAN KALY INTO A COLD FIRE WHICH WILL FOREVER FREEZE THE HEART OF THE SADHAKA. However, how can this statement be understood without knowing the

**Nimrod from**  
**Rosario**  
woman

**415**

Kaly? We are referring to a great Mystery by means of symbols, insinuating words that perhaps provoke an intuition; but Truth can only be known through struggle and confrontation.

The Kaly woman, in the West, will not be easy to find if she is sought with a mind loaded with dogmas and prejudices, with a heart sensitive to "Christian" morals, without hatred or love towards the family, that is, experiencing affective relationships. The tantrika is the hardest of the viryas: "hard among hard", and no one can walk his path if he is softened by Western culture or is sensitive to the illusions of life, that is: if he can still be captured by cultural facts and incorporated into the dramatic process of the psychoid archetypes. Why so many warnings: because the Kaly woman can only be distinguished BY HER ATTITUDE TOWARDS SEX and sex constitutes a "taboo" of the "western culture", that is: a preeminent cultural premise, which currently conditions people's judgment.

If we assume that the cultural barriers that would prevent not only to distinguish the Kaly woman but to accept her as an initiator have been overcome, we will be able to consider her psychological profile, the only way we have to recognize her. Indeed, within the confusion that reigns in Western societies, the Kaly woman must be located on the basis of her sexual behavior, a requirement that will be difficult to meet unless we have revealing psychological elements. We will give some of these elements and we will try to describe the psychological profile of the Kaly woman alluding to her most salient features, but, undoubtedly, these will shock the "Christian morality".

First of all, let us say that, if the Kaly woman is indispensable for the maithuna of the fifth Challenge, IT IS NOT NECESSARY FOR HER TO KNOW THAT SHE IS. In fact, it is convenient that the woman knows nothing of tantrism, nor of what is expected of her, in order to avoid her simulation of spiritual states or any predisposition towards maithuna outside of the strictly sexual. If you have a Kaly woman, it is not important WHAT SHE THINKS: HER PRESENCE ALONE ASSURES THE SUCCESS OF THE FIFTH CHALLENGE. On the other hand, it must be stated at the outset that, AFTER THE RITUAL MAI-THUNA, IF IT HAS FULFILLED THE OBJECTIVE OF AWAKENING THE SADHAKA, IT IS SUITABLE NOT TO SEE THE KALY WOMAN AGAIN.

All these conditions tell us that the Western sadhaka must prepare HIMSELF to pose the Five Challenges and that the fifth, the maithuna, must be practiced with a previously chosen Kaly woman, who will be "unknown", that is to say, of no or almost no dealings. In this way the reserved character that, as a "priestess", the yogini has to exhibit, is saved; in the West there are no priestesses.

The Kaly woman must therefore be taken in a hieratic sense, which restores the priestly character of her initiatory function. Let us now see what are the most salient features of the Kaly woman.

In the East it is affirmed that "the Kaly woman is a prostitute", but, naturally, the word "prostitute" there alludes to another meaning different from that of "sexual commerce for money" which is given to it in the West. There is a concept there, unknown in the West, of "sacred prostitute" to define a certain class of priestesses who, on certain dates, officiate at the tantric initiation (DIKSHA) of the sadhakas practicing maithuna. But such priestesses, although they copulate with different men in each initiation, do not do it for money, pleasure, or any other motive of material interest; but for the religious objective of "representing the wife of Shiva" during the magical weddings celebrated in the chakras of the sadhaka. What is unknown in the West is that "sacred prostitution" is not simply a practice that can be taught and learned by any woman, but that the Gurus specially select the women who are going to take the priesthood in order to detect the exact Kaly woman. So unknown is this subject that many people find it difficult to accept the fact that a Kaula Initiate can tell if a woman is fit to be a "sacred prostitute" just by looking at her eyes, even if she is a girl. The misunderstanding that this subject produces demonstrates the tremendous difference that exists between the Western and Eastern mentality ... with esoteric disadvantages for the Eastern woman. with esoteric disadvantages for the former.

To "observe her eyes" is not a euphemism, but a truth literally transcribed; for IN THE EYES OF THE KALY WOMAN IS ENGRAVED A SIGN OF DEATH. Whoever does not know how to "read" this sign, especially the western sadhaka, must distinguish the Kaly woman, as we have already said, by her sexual conduct. How: because there is something special in her sexual behavior that the Eve woman does not possess and that is perfectly explained by the oriental concept of "sacred prostitute". Indeed, the Kaly woman is a "prostitute": the Kaly woman is a "prostitute" but this word does not allude to "carnal commerce" but to a PARTICULAR ATTITUDE TOWARDS MAN'S SEMEN which only they possess and which, in the West, is very characteristic of true prostitutes, those who "make love for money" according to the commonplace, but which is by no means exclusive of "public women" but which also occurs very frequently among "honest women", that is, those who copulate as much or more than harlots but "do not do it for money".

Be that as it may, the important thing is that the Kaly woman shows "a particular attitude towards the man's semen" that characterizes her, which is innate, that is to say, "not acquired by learning"; and that can be anticipated if one knows how to read the "sign of

death" that is engraved in her eyes. We will express synthetically what such an action is, but it will be necessary to reflect a lot on it because there is here, concealed, one of the keys to the Mystery of Love: THE KALY WOMAN IS THAT ONE WHO ATTEMPTED TO EARN, BY ANY MEANS, THE SEMEN OF THE MAN. It is because of this characteristic that the oriental sadhakas must undergo a rigorous physical and mental preparation to control seminal ejaculation during the maithuna: it is not only a matter of seminal retention and inverting the sense of orgasm, but of overcoming all the powerful willpower that the Kaly woman applies to seize the semen and externalize it in the world.

To complete the concept, it is necessary to see in the attitude of the "Kaly woman" a dissociation of pleasure and sexual function. Pleasure is not usually for her the culmination of the sexual act, a kind of reward for a well-done gymnastics, but, on the contrary, there is an eternal dissatisfaction in the Kaly woman which constitutes one of the motives of her prostitution. It is not that the Kaly woman does not experience the pleasure of orgasm: her dissatisfaction is not physiological but psychological and we would even dare to say "spiritual", if we knew that we would not be misunderstood and that "it is known" what kind of woman we are talking about.

From what we have said about the Kaly woman, it is in the dissociation of pleasure that the fundamental difference with the Eva woman should be sought. The latter has as her main objective in sex the search for pleasure and it will never occur to her, except circumstantially or because of some perversion, to "provoke" anything in the man, much less to harbor the intention of extracting his semen AT ALL TIMES. Consequently, the Eva woman usually "gives herself" to the sexual act in a totally passive way, waiting to "receive" pleasure. The Kaly woman, on the contrary, is totally active and lucidly goes through the maithuna trying to provoke the male orgasm.

These "passive" and "active" attitudes of Eve and Kaly are related to certain ancient myths that the Hebrews expurgated from the Genesis accounts; accounts of Atlantean origin that Moses collected in Egypt. Before the censorship, Genesis narrated the story of Adam in Paradise making mention of TWO women who were his wives: the first, Lillith, whose magical name disappeared completely from the Bible but is still preserved in numerous Hebrew midrash; and the second, Eve, to whom Genesis attributes a fundamental participation in the fall of Adam, suggestively called "mother of all mortals". What happened to Lillith, Adam's first wife? Robert Graves, after researching together with Rabbi Raphael Patai hundreds of midrash and documents of the Jewish Tradition, has compiled the most important myths in his book "The Hebrew Myths"; there we read the following, such as

answer: "Adam and Lillith never found peace together; for when he wanted to lie with her, Lillith found the reclining posture he demanded offensive. 'Why should I lie under you? -I too was made of dust, and therefore I am your equal', she asked. As Adam tried to force her to obey by force, Lillith angrily uttered the magic name of God, rose into the air and left him."

Then, in another myth, it is explained that God created a second wife for Adam, Eve, using a rib or "the tail," as it is finally written in Genesis. There can be no doubt that the above myth, which was one day considered as true as the other stories of the Bible, is thousands of years old; and that it must register, like all myths, a transcendent origin, an allusion to some primordial truth. In this sense it should not be surprising that Lillith, after his flight from Paradise, became a demonic figure, a "demon of lust", according to Middle Eastern Traditions, especially Arabic, Jewish, Assyro-Babylonian and Sumerian; for, as we have already said, "Lillith in the world is Kaly".

It is not our intention to unravel the aforementioned myth; we only wish to point out that for thousands of years, long before tantrism existed, it was already known that the KALY WOMAN PLAYED AN ACTIVE ROLE DURING THE SEXUAL ACT AND THAT IT REQUIRED, FOR THIS, A DETERMINED POSTURE. And that is why

the western sadhaka has no need to study the Kamasutra to establish his position during the maithuna: the woman "below", in a passive attitude, corresponds to the "Eva" type; and the woman "above", kneeling, in an active attitude, clearly expresses the "Kaly" type.

The Western sadhaka who decides to pose the fifth Challenge must be mentally prepared to receive Kaly. Not for an instant can he think of obtaining pleasure from the maithuna and, on the contrary, he will try to envelop himself in an atmosphere of sacred expectation. The Kaly woman, we have already warned you, may not be pleasant, especially if she has been located in the world of prostitution; but this is inevitable because of the Mystery of A-mor. The Kaly woman, who is capable of revealing Kaly, also represents the Kaly Yuga; and that is why her ugliness will be all the more terrible the closer a society is to the "end of the Kaly Yuga", that is to say: the deeper we go into the spirit of the West. This is the hyperborean message contained in the denomination "Kaly Age", of which we spoke in another section.



The Kaly woman demonstrates a special attitude towards the man's semen which, as we said, is characteristic of the prostitute. We can draw certain conclusions from this statement, which will allow us to approach symbolically the black Kaly woman. In the first place, the Kaly woman, as a prostitute, does not copulate in order to procreate; and thus corresponds to the figure of Kaly who, being the external reflection of Lillith, represents the Hyperborean Feminine Spirit, which does not possess sex associated with a reproductive function. THAT IS WHY THERE IS A SIGN OF DEATH IN THE EYES OF THE WOMAN KALY: BECAUSE HER INFERTILE WOMB CONSTITUTES THE BURIAL OF THE HUMAN SEED. SHE INTENDS TO UPROOT THE SEED AND DEPOSIT IT IN HER WOMB; BUT SHE DOES NOT WANT IT TO BEAR FRUIT: THAT IS THE ATTITUDE OF THE KALY WOMAN. LUCIFERIC OF WOMEN KALY (or Lillith). She does not desire children; if she has them, they are "unwanted" and surely come marked by fatality. Nor does she desire pleasure like the Eve woman; and if she does accede to the maithuna she may do so for other motives, such as money, curiosity or intrigue. She also DOES NOT WANT TO BE LOVED, even though she usually accepts the feasts of her admirers who, generally, ignore the danger of the Kaly woman: SHE WILL DESTROY WITHOUT PITY THE IMBIBLE WHO DARES TO LOVE HER WITH HIS HEART.

On the contrary, the woman Eve "gives herself" to love and sex with the same unconsciousness, playing a passive and secondary role. In her fertile womb the seed fructifies and produces children of the flesh. But the most important thing is that the woman Eve is "mother", she represents the Cosmic Mother, the Feminine Archetype of the Shakti emanated by the Mind of the Demiurge, and therefore expresses the same FIXING character of the Kundalini Shakti. When the ordinary man associates his life with that of a woman Eve, the evolution of his family Archetype practically ceases; for he remains FIXED at the point of development reached up to the moment when the "bo- das of the flesh" are celebrated. From that point on, a process of improvement of the cultural structures takes place, which may give the impression of real progress, but this is only the perception of the unfolding of the "per- son" FROM THE FIXED LEVEL. The woman Eve, being a mother, fixes her "husband" at a certain evolutionary level of the family Archetype; but this does not worry anyone because people, out of fear, do not wish to progress too much in the development of the Archetype, preferring instead to remain within the formal limits to which the "gaze" of their woman of flesh confines them.

The woman Kaly manifests a particular predilection for destroying the work of the woman Eve, whom she despises, using for this purpose the power of her Sign of Death. She has the means to "enchant" the good husband and take him away from the circle of his marriage of the flesh, giving him the possibility to be reborn,

**Nimrod from  
Rosario**

**421**

that is to say, to begin to live another story, liberated from the fixating influence of the woman of the flesh.

meat. But, as soon as she has achieved her objective, the Kaly woman "breaks the spell" and abandons, as Lillith did with Adam, the lost virya who, if he is strong, will be able to overcome and will take the opportunity to live again; or, if he is faint-hearted, he will crawl again looking for the maternal protection and fixation of the woman Eve. It must be understood here that only those lost viryas who possess some possibility of "orienting themselves" are seduced by Kaly women, which constitutes, in a certain way, a privilege; although a whole bourgeois and pleasurable life may be destroyed. In short: after the Kaly woman has freed the virya from the spider's web of the Eve woman, he will be left to his own strength; and then he who is "eagle-like" will fly and prey; and he who is "worm-like" will crawl and be devoured.

The Mystery of the woman Kaly is profound, and in many respects unfathomable; it is opaque to merely intellectual inquiries. To know of Her it is best to enter into the living Mystery of Her person and to seek there, in the blackness of the Abyss, the revelation of the truth; each one will thus gather that part of the Mystery which corresponds to him or her according to the purity of his or her blood; And if that personal contact with the woman Kaly, from among the filth of her prostitution, the horrible figure of the ancient Goddess is seen to emerge, then yes, practically, it will be demonstrated that the inquiry was not in vain, that it was not a cultural whim but a cry that sprang from the river of pure blood. After the vision of madness, the virya will never be the same again; an effect that no literary commentary or intellectual explanation will be able to achieve. That is why it is futile, and to a certain extent sacrilegious, to comment, as we have been doing, on certain aspects, however exoteric they may be, of the Mystery of Love. We are persuaded beforehand that the esoteric truth will always remain hidden behind the symbols, so that our intention is simply to bring the Mystery closer, so that it, like a gravitational mass, attracts with irresistible force the consciousness of the virya. It has been no other criterion with which we have treated the Ritual of the Five Challenges, trying to induce intuitions that reveal the terrible Mystery of Love, whose esoteric essence is beyond, far beyond words and symbols. It is now up to us to complete the description of the fifth Challenge, where the previous comments and explanations will be summarized and make sense, and it does not seem idle to add one last warning: BE AWARE THAT NO ONE CAN EFFECTIVELY EXPOSE THE PSYCHOLOGICAL STATES OF AN INITIATIC EXPERIENCE. THE MOST THAT CAN BE CLAIMED, IN THIS SENSE, IS TO SHOW THE CONCRETE STEPS AND TO ALLUDE TO THE FUNDAMENTAL SYMBOLS.

What we will do, then, will be to TEACH A FORMULA for the Western Tantric initiation. But this FORMULA, which will be followed step by step by the virya Mengano,

will only be unraveled by those who have traveled the previous path, from the Family Test to the Fifth Challenge, and possess a heart as hard and cold as Mount Kailas. On the contrary, we discourage anyone who does not meet the required conditions from performing these practices.

In the Destiny of the Warrior there are certain particular moments during which the ancient archetypal symbols come to life and are dramatically inserted into its plot: the apprenticeship, the trials, the baptism of blood or fire, the combat, the battle, the defeat, the reward and punishment, the death, etc., are all milestones repeated a thousand times in similar circumstances by as many warriors. And in each of these moments the warrior experiences a characteristic state of mind, especially related to the concrete symbols of which the structure of the events is composed. Mengano, who is an expert warrior, has already known the joys of triumph, the patience of the besieger and the despair of the besieged, the fervor of battle, the pain of losing a comrade, the surprise of betrayal and the thousand feelings of love. In the warrior all the states of mind rest on Courage, without ever going beyond it. But the courage required to face the fifth Challenge is greater than that needed to face any other instance of the Warrior's Destiny, even the hand-to-hand struggle against a fierce enemy who tries to take his life. It should not deceive anyone, then, if we state that the state of mind of Mengano is one of serene expectation, of an almost religious disposition in the face of the imminence of the Mystery: beneath the serenity of the waters of the soul lies the steely depths of an unshakable courage; indispensable, moreover, when one has decided to resolve the Mystery of Love by the path of tantrism.

Whoever does not know the WAITING FOR THE A-MOR<sup>1</sup> will not be able to understand what is the state of mind that the sadhaka should be in when he poses the fifth Challenge. In the East, to overcome such a difficulty, it is required to WORSHIP THE GODDESS, DISCOVERING HER IN THE SHAKTI, that is to say, in the yogini. But this ADMIRATIONIS SACRA is less known even in the West. It is therefore perhaps worth clarifying that during the "waiting for Love" one experiences a chaste and chaste affection, "like the love of a sister or a bride", which cannot be tinged even for an instant with the fire of a passion whose origin is the desire to possess the woman physically; this last passion we call "animality", proper to the nature of the pasu. To understand why such a disposition of mind is NECESSARY, let us consider the following allegory: the sadhaka is in the case of one who has lost a precious jewel, a souvenir of his ancestors, of which he has long been ignorant of its whereabouts; suddenly, one day he discovers that he has lost a precious jewel, a souvenir of his ancestors, of which he has long been ignorant of its whereabouts.

---

1        *A poetic concept of the A-mor can be found in the book by MIGUEL SE-  
RRANO, "Nos, el Libro de la Resurrección", Ed.*

it had remained since then sunk in the mire of a fetid swamp; to rescue it does not seem to be a difficult task, however it is NECESSARY to prepare oneself psychologically to overcome the nausea that will come in contact with the miasma; if one acts with foresight, it will be possible to overcome the apprehension: let us suppose now that we have managed to rescue the jewel: between the muddy hands it does not shine: it is necessary to WASH IT WITH CLEAN WATER, to purify, to baptize, to remove the mud, to erase the stains, before ENJOYING ITS BEAUTY AGAIN; ONLY ONCE, IT WILL BE RECOGNIZED AS THE LOST JEWELRY.

AND THE JOY OF REUNION WILL ENSUE. In the same way, the sadhaka has to prepare himself to look for Kaly, the muddy jewel, in the swamp of the Kaly woman ... and it will be necessary to count on a lot of courage and decision, and on a modest and chaste affection, to overcome his nausea.

It is in the fifth Challenge, more than in any other initiatory path, that the Mystery of Death is most evident. To face Kaly means Death or madness, which is another kind of death. But from this Death it is possible to resurrect, to be reborn immediately; because the resolution of its Mystery, gnosis, places the sadhaka beyond its reach, making him immortal. Hence the NECESSITY OF Courage and of modesty: courage is necessary to overcome the modesty of Death, which is terror. As Lanza del Basto's Judas says when contemplating the carrion, *"The attention of you, Death, would devour us all at once if nature had not erected around all voluptuousness the wall of modesty. The modesty of you, Death, is terror, and rare are those who force it; your pleasure is abyss"*.<sup>2</sup>

Courage to overcome the modesty of Death, which is Terror; and chaste expectation to overcome the animal passions, are the two essential aspects of the "waiting for the A-mor". But, after the "waiting", comes Love, which in the allegory is symbolized by "the joy of reunion" in contemplating the lost jewel cleansed of all filth, that is to say, Lillith under the terrible veil of Kaly. This A-mor is different from love and we would even say contrary to it: when the A-mor is possessed, it is no longer possible to feel love for anything or anyone. Love is always "towards something", it requires an object of reference and, like all relationships, it depends directly on the cultural structure that determines, in different times and places, its characteristic "form": love is formally determined by morality, that is to say, by customs<sup>3</sup>. A-mor, on the contrary, does not register any object of reference because it is "subject of itself" and it is only possible to experience it when Kaly has been "reen- contracted" and the magical wedding has been celebrated, reaching individuality.

---

2 *JUDAS - Lanza del Basto - P. 98 - Ed. Goyanarte, Buenos Aires.*

3 *"Moral" comes from the Latin MORES = customs.*

Absolute passion. The A-mor is also, like the Gral, a reflection of the origin: but a reflection PROJECTED ON THE SELF; the A-MOR IS, THEN, THE INTUITION OF THE VRIL.

Nothing eternal binds him who has attained the eternal happiness of the A-mor; and for this reason, because they lack love for external objects, the Gnostics are feared and persecuted by the Synarchy. The A-mor, as we have said, is CONTRARY to love, but not OPPOSITE to it; nevertheless, this difference is not usually noticed, and A-mor is considered as OPPOSITE to love. But the OPPOSITE of love is, in fact, hatred; hence the identification of A-mor with hatred, which is nothing but malicious nonsense. The SS of the Black Order, for example, who received the initiation of A-mor and manifested "a total lack of love for the things of the world," were called "philosophers of hatred" by the panegyrists of the Synarchy. Naturally we are of the opinion that if to be courageous and hard, but at the same time beautiful as a God, and to despise the miserable work of the Demiurge, is to sustain a philosophy of hatred, WE DECLARE OURSELVES PARTIES OF SUCH A PHILOSOPHY! At any rate, we cannot A-love what the pasu loves and, surely, A-love what he hates.

The sadhaka Mengano, an ancient warrior, has already drunk the wine of pure blood, has eaten meat, fish and cereal, and has meditated deeply on the esoteric meaning of these Challenges. And, as a product of such meditations, he has predisposed himself psychically to "await the A-mor". Let us now see the tantric FORMULA used by Mengano when he presents the fifth Challenge.

With a woman Kaly, who is also a real prostitute, he has agreed for a sum of money to participate in the maithuna and has taken her, for this purpose, to a suitable environment, that is, to a place where it is possible to take a bath and already naked for as long as necessary<sup>1</sup>. There is no affection between Mengano and the woman Kaly, but the latter has not ceased to entertain and flatter her from the very moment they closed the deal, celebrating her "beauty" and showering her with "symbolic" gifts: flowers, perfumes, bracelets, cosmetics, etc.; and also promising future encounters in which his generosity will be even greater. Mengano procures,

---

1 *In this "formula" the type of the Kaly woman has been taken "ad extremum" by placing her in the world of prostitution. It must be stated that she could be found anywhere else and that, just as with the "lost virya" who ignores her hyperborean ancestry, many women also ignore it. These "lost viryas" do not know that the GODDESS OF DEATH DWELLS IN THE DARK SIDE OF THEIR SOUL, AND THAT HER TERRIBLE POWER ENABLES THEM TO SACRALIZE THE*



*WARRIOR'S LOVE.*

by such unusual conduct, to create the sensation of being "inexperienced" or "foolish", to provoke in the Kaly woman greed, vanity and contempt, and to definitively avoid the possibility of any positive affection arising in her.

While the Kaly woman waits naked on the bed, indulging in the idea of plucking the unwary sadhaka, he takes a bath during which he intensifies the state of mind of "waiting for the A-mor," which we have already defined. Before leaving the bath, Mengano reviews the "pieces" of the family Archetype, Zutano, Montano, Bellano, etc., making sure that it is complete inside him; when he perceives the unmistakable sensation that the flow of his river has multiplied, only then he enters the enclosure of the Kaly woman.

The eyes of the Gnostic pierce the illusions of the world to see other realities that lie beyond the cultural veils, that is, beyond the Strategy of the Great Deceiver. But this gaze brings to consciousness dramatic images that reveal the Presence of the Demiurge in every atom of matter: it will no longer be possible for the Gnostic to contemplate nature as "landscape" because the process of the psychoid Archetypes that sustain it unfolds before his acute sight. That is why, when observing the naked Kaly woman on the bed, the sadhaka cannot help but think of the swamp that hides under the filthy mud the jewel lost in the past. O blackness of body and soul, in what depths shall we find the light of forgotten Truth? In that prostituted body, behind that degraded will, under that carnal beauty that vanishes showing the corruption on which it rests, there, - see all! - hides the Goddess of Death. O Lucifer, give us the strength of your Green Ray to resist the vision of the Black Face! Only thus will we be able to return to the world the apples of the Primordial Betrayal! And only thus, O Lucifer, will we be able to find Lillith again, and strip her, and then, once transmuted, take the inverse path that will lead us to your army of immortal heroes!

The contemplation of the Kaly woman, for the one who has disposed himself to "wait for the A-mor", produces an ADMIRATIONIS SACRA, an experience of supreme transcendence; but it is not possible to extend oneself more than a few moments in it.

The sadhaka Mengano stands next to the Kaly woman and entertains himself for a few minutes in an erotic game that consists in touching, repeating internally certain mantras, her erogenous zones. The purpose of this exercise is not to excite the Kaly woman, a remote possibility to achieve in a sex professional, but to gain her confidence for the request of the BLACK KISS. Before explaining what it is all about, it is worth mentioning once again that the Kaly woman WILL TRY TO PULL THE SADHAKA'S SEMEN.

BY ANY MEANS, which constitutes a danger, during the erotic foreplay, that can cause the failure of the sadhana<sup>1</sup>. That is why great concentration is required, not only in the seminal retention but also in the "chaste and chaste" state of mind, which will avoid being dominated by animal passions.

The sadhaka Mengano has turned his back for the Kaly woman to admire the BLACK KISS, about two inches above the anus; and as she does so he, holding his breath and directing his consciousness towards the egg where Kundalini shakti sleeps, pronounces the mantra "LILLITH". THIS IS THE FIRST CALL TO LILLITH. After the BLACK KISS the maithuna should begin. For this the sadhaka lies down with the Lingam<sup>2</sup> facing upwards and asks the Kaly woman to place herself in the "Lillith position", that is to say, on her knees, sitting on her body, AND TO STAND LIKE THIS. In this first part of the Maithuna the lingam should remain introduced into the yoni<sup>3</sup> WITHOUT THE BODIES MOVING, for a fairly long time. The sadhaka's hands, at least at some point, touch the breasts of the Kaly woman; but then he places them, with the mudra of the fist, on her navel.

It is at this moment when the fate of the sadhana is at stake and the success of the tantric initiation depends only on the blood purity of the sadhaka.

Closing his eyelids, but not enough so as not to see through them, and trying to prevent the Kaly woman from noticing if she is being watched, Mengano then performs one of the most delicate steps of his "formula": HE PLAYS TO BE A RIVER. He identifies his consciousness with the liquid current and soon feels himself running, sliding down a channel, converted into a murmuring stream. It should be noted that this experience fails IF ONE ONLY SEES THE RIVER AND DOES NOT EXPERIENCE BEING A RIVER. On the contrary, IT IS NECESSARY FOR THE CONSCIOUSNESS TO BE LIQUID AND TO SPILL INVERSE THROUGH A CHANNEL THAT HAS EVER HIGHER AND HIGHER PENDENCY.

At first Mengano was a stream of crystalline water flowing merrily along a low-banked channel; his "I" was everywhere, but mainly on the surface, placidly contemplating how the grassy fields were left behind, alternating, from time to time, with black forests of ash trees. And suddenly, as I rounded the side of a polychrome hill, amidst swirls of protest and splashes of joy, the confluence of another stream came to add

---

1 SADHANA = *tantric "practice"*.

2 LINGAM = *penis*.

3 YONI = *vagina*.

more flow to the current of the Mengano. In a short time, after several similar confluences, the Mengano felt like a mighty river that advanced arrogantly through a valley of low hills, sharply cut out against a blue sky, without nuances. The willows, bent lazily, were pleased to caress with their branches the waters, no longer so clean but more and more violent and roaring. Countless days and nights went by while the river Mengano, already very torrential, continued ascending the ancient riverbeds, overturning in thundering waterfalls, hitting with tenacity the rocks on the banks, sometimes uprooting the weak trees and without the sun warming its flow to carry away the water, which was then returned by the refreshing rain. As the tributary streams were added, the waters of the Mengano became more and more alive; it was no longer only fish, reptiles and crustaceans, camalotes, ferns and royal victories: a whole universe of living creatures inhabited and nourished by the river of conscience! Most of such beings were unknown UNTIL THEN to the astonished gaze of Mengano who, for the first time, understood what a LIVING OBJECT-SYMBOL-LIVING. There are certain organs in the human body which culture assures us are common to all men, and of which we suspect their existence in our body, but which we can never see unless we practice our own dissection; in the same way, as if we could suddenly become conscious of those organs, of which we possessed only obscure intuitions, so was the discovery made by Mengano of those living symbols, which were as much his own as the organs of his body and which had hitherto remained undifferentiated as the latter. And so, as he flowed in a torrent through a country of high snow-capped mountains and fearful blizzards, he was conscious of the overwhelming multiplicity of himself and wept brackish tears that sank into the depths of his liquid consciousness.

The tributary rivers became more and more spaced out until they disappeared completely. By then, the Mengano had become a very wide and torrential river that still ran roaring between snow-capped mountains and lazy glaciers that discharged their icy icebergs into the water. Soon the mountain ranges, which opened up on both sides of the Mengano River, began to separate from each other, leaving the space of a great valley free. The width of the river also increased, although the depth decreased, and its waters abruptly diffused into an enormous estuary, the mouth of which seemed to connect with a sea of unmeasurable size. But it was not a sea but another river, of immense flow, which Mengano immediately recognized as the "Villano River", the hyperborean current of pure health THAT LEADS "ADVERSO FLUMINE"<sup>4</sup> TOWARDS THE EXTRATERRESTRIAL ORIGIN.

---

4 *ADVERSO FLUMINE: upstream, against the current.*

of their lineage.

When the flowing consciousness that was the rivergano flowed into the Vian River, it experienced in an instant that miracle that is called Gnostic Expansion. As if an enormous drop of oil were spreading over the water in all directions, so did the consciousness of Mangano expand gnostically. And a new and infinite multiplicity of living-symbol-objects was incorporated into his consciousness emerging from the newly discovered waters. The "madness", thought Mengano, consisted undoubtedly in letting himself be absorbed by the flow of that fabulous River; and really only the previous training, his limitless courage and the state of mind he still had, of "waiting for the A-mor", were saving him from losing himself in the unconsciousness of those dark and impenetrable waters, but teeming with unmanifested life. For the River of the hyperborean inheritance was a frightful hotbed of living symbols and of all kinds of objects, either floating or sunken, that demonstrated its insane opulence: there were there, for example, islands inhabited by dead ancestors, who greeted with vehement cries the reverse passage of the liquid consciousness; and ancient submerged cities; and ships of a thousand different epochs sailing with uncertain course; and unknown or perhaps non-existent animals; and infinite other mara-villas that it would be impossible to describe. The Gnostic expansion led Mengano to discover a new world; but that world was the world of the primordial madness that occurred after the Betrayal of the Siddhas and the Fall of the Spirit; from there on he could not return WITHOUT FALLING AGAIN INTO CONFUSION, because the "frightful boiling pot", which was being left behind, would cut his way by modifying the channel through which he arrived at the Villano River, or by opening other channels that would only be channels without exit. In fact, Mengano was aware that the estuary and the parallel mountains no longer existed and that, if he were to turn back, he would only find himself lost in madness.

But such a dire possibility did not worry Mengano because his decision to go to the end was unshakable and, moreover, his will was gnostically fortified as the ancestral current brought him closer to the origin of the Mystery. Mengano, at that point in the journey, had noticed that the mantle of a growing penumbra was covering him as he advanced. Soon he understood that the waters of the Hyperborean River flowed through the bottom of a monstrous and deep canyon excavated in the black rock, after a fluvial erosion of millions of years, whose towering walls prevented the arrival of light. But the gloom became even greater as the canyon narrowed constantly, until at last it became a sharp gorge through which water gurgled and gurgled. And then, yes, the darkness was total.

The gloomy depths of the gorge through which he was sliding prevented him from warning in time that the riverbed was going to die against the side of a colossal mountain, tinged with a marvelous golden color; so he could only have a fleeting glimpse of it before he was precipitated into its entrails, when the entire flow poured through a terrifying yoni-shaped crevice. Although the waters, liquid consciousness, completely filled the capacity of the stone tunnel, Mengano sensed in some mysterious way a distant bellowing sound, which at times resembled a piercing howl and made him think of a badly wounded beast. It had been circling the interior of the golden mountain for quite some time; and as the flow was very strong it was to be supposed that, if it had not yet crossed it, its diameter must have been exceptionally large, a quality that provoked the admiration of Mengano. Soon the roar was deafening and it became clear that no beast was badly hurt, but that the roar was produced by the waters as they fell to even darker and more terrible depths. And the titanic cascade also consumed the liquid consciousness of Mengano; and he, as he fell irremediably into the abyss, also roared and bellowed, in a berserkir fury.

After such an atrocious and resounding fall, there came a sudden stillness that Mengano could only appreciate when he managed to overcome the violence of the jump and the terror of the abyss.

Amazed, he understood that the waters of the Hyperborean River fed a lake located inside the golden mountain, in the center of an enormous cavern whose dimensions he dared not imagine. A soft twilight, apparently caused by the phosphorescence of the rocks, contributed to increase that magical climate of peace and serenity. If he had a human face, Thingy would have smiled, but his joy at having arrived there, after having traveled such a long distance, was also manifested in that soft ripple that shook the surface of the lake and that was, in a certain way, an aquatic smile.

Having lost the notion of time, he could have remained there indefinitely, with his consciousness diffused in a soft backwater that caressed the rocky shores and received on its surface the faded reflection of the twilight cavern. Yes; it would have remained like that for a long time, like a pool of consciousness, IF A MOVEMENT IN THE REFLECTION had not abruptly attracted his attention. Something had moved on a less illuminated part of the shore! And Mengano, who had thought he was alone, suddenly found himself sharpening his liquid perception to capture with the mirror of water on his face the cause of that movement, a cause that apparently could not be "living" since life was inconceivable there, in that unknown cavern hidden in the rocky entrails of the golden mountain. But the image of horror

that was reflected in the "Pool of Mengano" disproved this supposition: it was without doubt a "man" who had been leaning against the trunk of the apple tree, next to the shore, and who now struggled upright! But when he was fully upright, he realized that the White Giant was not human; and he had the feeling that he was facing the Great Hiperborean Ancestor. He wanted to preserve his pond-like serenity, but a senseless terror stirred in the depths of his liquid soul; and, when the Giant came close enough to reflect a clear image, something LIKE AN UNCONTAINABLE RUBOR produced concentric circles on the surface, ripples that betrayed gano's stillness. An infinite shame seized Mengano upon discovering, reflected in the mirror of water of his conscience, the primordial misery of himself. And to such confusion was added the horror of seeing that the Giant's face was turned BACKWARDS, as if in a remote time he had turned his head a "half circle" and it was then welded forever.

What impressed gano most, however, was the knowledge that THAT WATER which filled the subway lake, and which was the source of the Villano River and of the countless rivers he had traversed in reverse to get there, WAS FLOWING ABUNDANTLY FROM A WOUND IN THE CHEST OF THE GI. GANTE. Upon learning of that millenary torment, which had left a wound of pain on the face of the Great Ancestor, a last and terrible shudder completely shook the conscience of Mengano.

Unable to contain himself, Mengano's voice rose from the liquid surface:

*- Lucifer, oh Lucifer!*

And like a bitter lament, the Voice of the Great Ancestor asked:

*- Who has pronounced the name of the Great Chief? -And then he continued, "I have felt the Fountain of Pure Blood stirring...."*

*- I don't know your name... -replied Mengano from the surface of the pond.*

*- Every name is a catastrophe, a blight in the hell of the Demiurge ... Before we were not named because we knew how to Name ... But you, Mirror of the Pure Blood, you are tarnished by the madness of the world and you need words ... I was ANIR, remember? But am I still? Mirror of the Pureblood: your madness in asking about me is a reflection of my own madness, of the ancient misdirection that has plagued us ...*

*tplicated and immersed us in the dregs of matter ... At first we loved, remember?  
... At the beginning we love ...*

*- I have come to seek you, O Anir," the voice of Menga Pond trembled, "not for  
you to guide me to the origin of our immortal race. Will you be able to do it?*

*- I can no longer see the origin, do you not understand that my face is turned  
elsewhere? And besides, I am dying ... I have been wounded at the Beginning,  
during the combat of A-mor, and the wound inflicted will never heal again ...  
Unless She ...*

*- Oh Anir, I wish to cure you! -You will be able to recover your eternity!  
The woman Kaly has come with me and is waiting for you OUTSIDE! She will return  
your honor if you grant her the honor of betrothing her forever! O Anir, Great  
Hyperborean Ancestor, Root of my Stirp, never again forsake Kaly!*

The wounded Giant sighed, with a gesture of infinite weariness, while in his eyes glowed the fire of the old unquenched passion, renewed now by the promise gushing from the pool of Mengano to meet again the woman Kaly.

*- Yes," assured the Great Ancestor with insane resolution, "you say well, Mirror  
of the Pure Blood, I am ready to complete my death, and then to die a thousand  
times more, JUST TO FACE HER FACE AGAIN! ... O Mirror:  
What happened to us? what is this drunkenness of the Abyss with which we have  
been defeated? We were like gods ... If I at least kept my trident, the new fight  
would be more even ... But like this, wounded and shackled, without the possibility  
of looking at the Origin head-on because I have no face to face, I am condemned  
to eternal loss!  
... Unless She ... But I must not keep the Promised One waiting!*

Then, staggering forward, stumbling over the chains that held his ankles, bleeding profusely from the ancient wound, NOT SEEING WHERE HE WAS GOING, for his face was "turned to his back," the Great Ancestor wanted to walk in the direction of the pool. But although he was only a short distance from the subterranean lake, it was not an easy task to reach it, for a centuries-long training had stiffened his limbs; nevertheless, he immediately rolled over the rocky ground, slid down the slope of the shore and finally sank silently into the living waters of the pond of the Thingy. And Mengano, at that moment, had the sensation of being in the center of an explosion of fire that expanded to embrace not only the Rivers of the Pure Blood, but also the entire microcosm.



The sadhaka Mengano never believed, before that maithuna, that he would come to know such a terrible and voracious passion as that, which constituted, however, the only motivation TOWARDS THE EXTERNAL WORLD on the part of the Great Ancestor. But such a gnosis was necessary, as we shall see, to COMPLETE THE FORMULA of the fifth Challenge.

When the Great Ancestor was immersed in the mirror of the pool Mengano, there was no longer any object to reflect, no longer any reflected image, all difference was consumed in the explosion of fire, and the consciousness of the virya Mengano and Anir were once again one. THE TOTALITY OF THE BLOOD WAS THEN "PURE", GNOSTICALLY TRANSMUTED, BUT IT WAS ALSO "FIRE", BY THE MYSTERY OF A-MOR. The next step of the FORMULA was fulfilled at that time of igneous expansion and transmutation of the blood.

From the beginning of the maithuna, and Thingy PLAYING TO BE A RIVER, until the moment of the igneous expansion and the Return of the Great Ancestor, only a few minutes had elapsed, perhaps ten or fifteen; but during that time the Kaly woman remained motionless, in the position of Lillith, for it was so agreed beforehand. However, after the Return of Anir, without being clairvoyant, anyone would have noticed that the Sadhaka's countenance glowed in an expression of luciferic happiness; while a closer inspection would have noted the soft greenish aura that now extended around his body. The Kaly woman could not fail to notice the change, and it was perhaps because of this, or because of an unconscious compulsion, that she began to move rhythmically with the made-up decision to ROCK THE SADHAKA'S SEMEN. While her enthusiasm was increasing, Mengano (or Anir) gazed at her hard face unnoticed, for he had narrowed his eyelids to allow only a weak ray of light to pass through. He did this because he awaited the moment when the sentence of the Hyperborean Tantra would be fulfilled: THE HATRED OF THE KALY WOMAN OPENS THE GATES OF ETERNITY. And in this sentence rested, to a great extent, the success of his FORMULA.

According to the Hyperborean Wisdom, the true solution lies in this sentence. to the Mystery of the Sphinx.

To apply this sentence in the sadhana, the Hyperborean Tantra states that: "DURING THE MAITHUNA WITH THE KALY WOMAN, IF THE SADHAKA SUCCEDES IN WITHHOLDING HIS SEMEN BY PREVENTING HER FROM SEPULATING IT IN HER INFECUNDAL WOMAN, THE HATE OF THE KALY WOMAN WILL OPEN THE DOORS OF ETERNITY". Hatred is produced when it becomes clear to her that she will not succeed in "pulling out the semen"; it is at that moment that "the gates of eternity are opened"; that is why it is

**Nimrod from  
Rosario**

necessary to be attentive, without

that she notices it, to the variations of her hard face; for, as Tantra Hi-perbóreo, "THE DOORS OF ETERNITY ARE THE EYES OF THE KALY WOMAN". No It is convenient to add further commentary to this Mystery; but it is worth remembering that by observing the eyes of the Kaly woman, one is contemplating a SIGN OF DEATH.

The gaze of Mengano, as in a dream, was fixed on the eyes of the Kaly woman; while the latter, panting rabidly, raised and lowered her body to rub the lingam with her yoni. And the eyes of the Kaly woman, bright with lust, were also fixed on the face of the sadhaka, trying to guess the moment of her orgasm and simulating with feigned sighs and studied cries the orgasm itself; she tried to deceive the sadhaka about the effects that his virility supposedly produced in her, to induce him in this way to complete the coitus. But, as time went on without the maithuna culminating in the se- men's ejaculation, the fury of the movements was tempered; and when, at one point, the Kaly woman was convinced that the orgasm would never come, A SHEER OF HATE EMERGED FROM THE BLACKS OF HER SOUL AND BURST ELECTRICALLY. ON HER FACE. It was only an instant, but it was enough for Mengano-Anir's attentive gaze to discover that the Kaly woman's eyes had transformed into two windows of terrifying blackness.

We must declare that this is the crucial moment of the fifth Challenge: If in the sadhaka the Will of the Great Ancestor predominates, then all will be lost: FOR HE WILL FALL BACK and, in that instant of maximum bioelectrical tension, HE WILL LOVE OUTSIDE THE WOMAN KALY, AS HE LOVED THE WOMAN EVA BETWEEN. GENDERING HIS SEED; but if it is the re-oriented "I", which seeks the inverse path of the return to the origin, who imposes the will in the conduct of the sadhaka, in-mortality will be possible because the latter will not fear TO LOOK AT ETERNITY.

In the sadhaka Mengano predominated, even over the devouring passion of Anir, an unbreakable will to return to the origin. That is why, when the eyes of the woman Kaly were like dark cracks, beyond the Sign of Death, Mengano peered into her Mystery and understood that those Gates of Eternity led to a Night blacker than all the nights created by the Gods, to an Emptiness that would never be filled by anything or anyone, to an absolute and unknowable Nothingness that, however, was reason and matrix of all Being. And then occurred the miracle forbidden to mortal nature: MENGANO FEELED A-MOR FOR THAT ETERNAL NIGHT, KALY! Oh, KALY!

For an Alchemy that only those who have penetrated the terrible veil will be able to know. of the Mystery of A-mor, the HATE OF THE WOMAN KALY TRANSMUTED INTO THE



To KALY: What happened next: the cold. The cold of the Eternal Night extinguished the primordial passion in the sadhaka's blood and left his heart frozen forever.

Feeling his heart frozen with A-mor, the gaze of Mengano returned from the depths of the Eternal Night to the socket of his half-closed eyes; and then, opening them, he saw with horror that the Eternal Night also A-maba him and had followed him to his world, CROSSING IN REVERSE THE SIGN OF DEATH. For there was no longer the woman Kaly but a fearsome and vengeful Deity who demanded immediate death by A-mor.

Kaly was the representation of the Eternal Night and as such she was black and terrifying; she was naked and her forms were not beautiful, but opulent and coarse; from her neck hung a necklace with countless skulls strung like beads: they were the heads of her lovers, those who had died for A-mor to Her, killed by Her; for the Goddess is the Supreme Prostitute, the one who shares the A-mor with all her lovers, but she is also the Jealous Wife, the one who does not accept to be betrayed by any of them. And although he knew what She would demand, contemplating her dancing on his belly, Mengano again felt from his heart of ice that he A-mored her beyond all limits. So, holding his breath, he brought his consciousness to the egg of Kundalini shakti and, upon it, twice projected the mantra "Lillith". THIS IS THE SECOND CALL TO LILLITH.

The sadhaka Mengano watched under the spell of A-mor as Kaly danced around his erect lingam the dance of immortality, drawing with his feet and with the mudras of his hands the Runes of Death. When he verified that the Goddess had already danced four times, he knew that at the end of the fifth time he would die. And notwithstanding this certainty, he calmly awaited the fifth round. And only when the sword rose up threateningly, held by an iron and black arm that frantically changed its place to the rhythm of the dance, Mengano managed to hold his breath and project on the Kundalini shakti egg, for three times, the mantra "Lillith". THIS IS THE THIRD CALL TO LILLITH, and it is the final step of the FORMULA.

At the third naming of the mantra, THE EGG BROKE! And from within the torn membranes was born to life the plasmating Logos, in its turn, in the hyperborean form of the Divine Lillith. But so perfect was her Beauty, so blinding the light of her blue gaze, so intoxicating the perfume of her silken hair, so sweet the sound of her laughter, so soft her velvet skin, so irresistible A-mor's desire for her Absolute feminine presence, that TO SEE HER AND TO DISPOSE OF HER IS ONE ACT. That is why, when the egg is broken, instantly the inner orgasm is produced, with the semen leaping inward to fertilize the Bride,

who will only give birth to the "Son of Death". Indeed: Lillith has been betrothed by the Great Ancestor and this is the one whom she will immortalize by recreating the microcosm with the power of her Word, as already explained above; but by recreating him, she BORN HIM AGAIN and he is, therefore, her son, a Son of Death.

We are exposing separately aspects of a single act; for at the same moment of orgasm, while Lillith is betrothed "inside", a violent double man was severing the head of the sadhaka Mengano; but that head was also the head of the Great Ancestor Anir, the one that could not look towards the origin; And that is why the sadhaka Mengano, feeling the horrible cracking of the cervical vertebrae as they broke, while sinking into the Black Night of Death, thought that losing that lost head was undoubtedly a liberation. And so it happened that an instant after betrothal to Lillith, her Bridegroom died decapitated; who would be resurrected after another instant as the Son of Death. And she, who was born already betrothed, became almost immediately a Widow.

Here are the paradoxes that occur IN ALL THE WAYS OF LIBERATION: THE IMMORTAL SIDDHA IS THE SON OF HIMSELF, AND ALSO THE SON OF THE WIDOW AND THE SON OF DEATH.

But only the KULATANTRIKA, who has offered his head on the altar of Kaly, is called CAPUT NIGER, BLACK HEAD.

Let us return to the fifth Challenge. After decapitating the sadhaka, Kaly threaded his head on the necklace and then, always dancing, he penetrated into the newly resolved body of the sadhaka. He did it through the side, inserting and closing it behind him, in that ancient wound that some believe Jesus Christ also had.

We repeat again that the murder of the sadhaka by Kaly and the birth and marriage of Lillith occur simultaneously, because such events are different aspects of one and the same act: the consummation of the A-mor. When the sadhaka A-mor Kaly "outside", he recovers Lillith "inside", consummating with her the magical wedding, the coitus from which the Son of Death will be born; that is why the happiness of possessing Lillith is indescribable, as is the ecstasy with which the maithuna culminates, the orgasm of the loveless A-mor in which the semen LEAPS INWARD and repairs the Original Error.

There should be no doubt about the birth of Lillith from the rupture of the Kundalini shakti egg: LILLITH HAS NOT BEEN "CREATED" BY AN ACT OF IMAGI-

IT SHOULD NOT BE IDENTIFIED WITH KUNDALINI. On the contrary: KUNDALINI IS TO LILLITH AS THE HUMAN BODY IS TO THE HYPERBORNE SPIRIT:

A VEHICLE OF MANIFESTATION. The formula to recover Lillith has been the following: contemplating the ETERNAL NIGHT, through the eyes of the kaly woman, the sadhaka projects his faceless memory of the hyperborean woman; and THE BLACK ETERNITY, FROM THE SUNAIDA MATRIX, RETURNS TO THE SADHAKA THE FACE OF HIS A-MADA, WHAT IT MEANS: IT UNVEILS FOR HIM THE VEIL OF OBLIVION AND CONFRONTS HIM WITH THE SPIRIT OF THE HYPERBOREAN WOMAN WHO WAS HIS WIFE OF THE

ORIGINS. But this long-awaited contact is given THROUGH THE WORLD, THROUGH THE WOMAN KALY; and that is why the spirit of the hyperborean woman manifests itself first externally, coming from eternity TOWARD the world and FROM the world TOWARDS the sadhaka. It is necessary, then, to give a body to the Spirit, to A-mar it and to espouse it. On entering the world from Eternity, the Spirit of Her is Kaly; and because she is Kaly, she already has a face; and by shaping with her face the egg of the Shaping Logos, she already has a body; but, on breaking the egg, Kaly "enters" because she is "the Spirit of Her", who must be born with the Beautiful Face of Lillith; but, before entering, she murders the sadhaka by decapitating his inverted head, for only he who is killed "from without" can be resurrected "from within".

There is another terrible aspect of this Mystery that we cannot avoid: in order to achieve immortality, Lillith must be espoused; therefore: Lillith must live! For Lillith to live, it is necessary to give her a body of Kundalini shakti, thus the egg must be shaped! To shape the egg one must have Kaly's dance; therefore: Kaly must reveal himself to the sadhaka! For Kaly to reveal himself, the hatred of the Kaly woman is necessary; therefore: The Kaly woman will make it possible for Kaly to emerge! For Kaly to emerge the Kaly woman will open her eyes to eternity by reversing her Sign of Death which will no longer be towards "outside" but towards "inside"; therefore the Kaly woman must die!

Indeed: the immortality of the sadhaka implies the death of the Kaly woman. Initiatic death, symbolic death or real death by disincarnation? Who can answer with certainty? Each Western sadhaka, like Mengano, will have to resolve this Mystery for himself.

We have expounded in some detail the "formula" of Mengano to demonstrate that tantrism is something more than an erotic game or a series of sexual techniques to "improve the conjugal union". We follow this path because we want to discourage tantric practices in those viryas who are not capable of A-mar to Kaly. Because this path only offers liberation to those who, like Mengano, are not

**Nimrod from  
Rosario**

**443**

afraid to surrender their skull to adorn the necklace of the Goddess.



As an epilogue to the 8th commentary, we can summarize what has been said by affirming that Mengano, a Western sadhaka, successfully performed the Ritual of the Five Challenges and achieved his strategic objective of immortalizing the physical body and attaining absolute indivi- duality. However, we understand that such an epilogue, although accurate, may be insufficient for those who wonder about the steps AFTER the initiation of Mengano: - is it never possible to talk about what happens AFTER the initiation? We are shown a Ritual in which Kundalini is awakened and the physical body is immortalized, does that mean that the Vril has been reached? And, ... etc. etc.

Naturally, it is not advisable to answer such questions rationally; and that is why no one who possesses the answers will agree to comment in this way on the Mystery of rebirth and immortality. We can, however, approach the Mystery if we have recourse to the symbolic language in which it is expressed. Here, then, is a new epilogue:

*She and he walk hand in hand along a sandy bank, flanked by varied foliage. At last they stop; in front of them is the water. Pointing with his index finger to the distant horizon, he says:*

*- Beyond the water is the mountain and, behind it, the Vril. We have the gnosis; we only need to recover the Power, O A-mada.*

*And she, smiling sweetly, replies:*

*- O A-mado: the End and the Beginning are now within our reach, where to? will we go?*

*- We must go to the Beginning," he replied, "which will be our End.*

*- Oh, A-mado: will we be able to abandon these delights again? ... How long have we been apart. !*

*- We shall be strong! No longer will I love you on the beach, nor in the water, you who are soft as a breath; now my heart is frozen with A-mor, and your face, glowing with whiteness, A-ma me from the eternity of the Night. Listen, A-mada, to the secret that has cost us so much to know: The Great Deceiver has erected a Paradise around the Vril. Many return to Paradise, but few dare to CROSS IT and go beyond ...*

*And they continued to hold hands. Sometimes he would stop and dance, and then she would call him Shiva. And when she danced he would give her sweet glances and call her Parvati. But at other times He would unsheathe His sword, radiant with beauty, and She would become light and fly like the wind; and then they were Lucifer and Lillith, marching towards the origin.... And they had many other names that were, like these, residues of ancient rounds of A-mor.*

*One day they arrived very close to the place where they had entered in the past, in that time without Time when they did not yet know the meaning of the word "tear". They recognized with horror the forest of apple trees and listened how their fruits called out to them, amidst laughter and promises. But this time they did not stop. And as they left the enchanted forest they saw, shuddering with happiness, that the vehicle that had once brought them from Hyperborea was still abandoned in that place. Seen from the outside, it appeared to be carved in marble, with its eight windows and its pointed tower, similar to the helmet of the Thai priests. They entered from the side, through one of the windows, and placed their feet in the circular corridor inside. Before embracing and covering each other with mutual caresses, they took a last look through the windows at the Horror of the Beast. Then they embraced each other unreservedly, free now from the Madness, and then, as their backs were still turned, **THEY HASTENED TO TURN THEIR FACES INWARD INTO THE SHIP, TO FACE THE TRUTH.***

## THIRD LECTURE

*(Part of the text was omitted, perhaps the author decided not to publish it yet).*

## A.

It has been repeatedly affirmed that there are two Kabbalhs and that both deal with the creation of the world by the Demiurge The One. One, the Numerical Kabbalah, contains the secret of the ten sephiroth and the twenty-two soni-two; it enables one to obtain the keys to the collective psychoid Archetypes (manúes) and to know the Plans of the terrestrial Demiurge Sanat Kumara or Jehovah-Satanás. The other, Acoustic Kabbalah, deals with the way in which these Plans can be put into practice (through the mastery of the sonoriferous ether or AKASA TATTVA) and makes it possible to elaborate procedures for influencing the physical world.

The numerical Kabbalah facilitates control over crowds and men IN COMBINATION WITH CONCRETE ELEMENTS OF THE ACOUSTIC KABALA. The Kabbalah acoustics enables thaumaturgy and the exercise of the totality of the occult arts IN COMBINATION WITH SYMBOLIC ELEMENTS OF THE NUMERAL KABALA. Both doctrines are, therefore, complementary and necessary for magical praxis.

But since the numerical Kabbalah is the object, almost exclusively, of study by Jewish sages, and the acoustic Kabbalah, at least in the last three thousand years, is the domain of the Druids, this complementation has not offered problems to two races engendered by Jehovah-Satan, accomplices and executors of the Plan of the Synarchy. But this was not always so. In the Christian-Luciferic period of Atlantis, during its hyperborean splendor, the numerical Kabbalah, which was a theoretical doctrine for the symbolic interpretation of the world, could be studied by anyone. For millennia it was a collective cultural heritage, and so it continued, until the final cataclysm that submerged Atlantis. This is the reason why some surviving ethnic groups, and others who were vassals and inhabited contiguous lands, possessed and preserved originally Kabbalistic knowledge such as mathematics or astronomy (Egyptians, Sumerians, Mayans, etc.).

Contrary to the vulgarization of the numerical Kabbalah, in Atlantis the acoustic Kabbalah was known only to Hyperborean initiates, as long as the Luciferic period lasted. Later, when Satanism was a current practice by the priestly caste, much of the doctrine was lost and, after the collapse, practically disappeared as "initiatory knowledge".

However, a small remnant of survivors - who were neither black like the Egyptians, nor red like the Toltecs, nor yellow like the Mongoleans - possessed enough PRACTICAL KNOWLEDGE of Atlantean science to reconstruct the acoustic Kabbalah, had they wished to do so. This group is what modern anthropology calls "Cro-Magnon men" and who in reality constitute the true ancestors of the white race.

In Atlantis there was NO MAJOR WHITE RACE. The Cro-Magnon was a minor race of viryas taken under the protection of the yellow-race Hyperborean Siddhas who were entrusted, during the Luciferic period, with a collective mission linked to the acoustic Kabbalah: to be the guardians of the Lithic Wisdom<sup>1</sup>. They, better than anyone else, possessed the secret of the stone: of carving; of its transport by levitation; of the telluric resonance that allowed to take advantage of the energy currents of the Earth; of the construction of rock crystal transducers, whose use as "oracle" was so well known to John Dee and that could constitute, depending on the type, a "ray-throwing" weapon, a "lamp" of perennial flame and even a flying vehicle. The lithic technology of Atlantis would seem even today, that we have developed techniques to build "solid state" integrated circuits with 50,000 silicon crystal transistors, oxides, etc., amazing for the precision and effectiveness it had achieved.

After the sinking, the Cro-Magnon whites, guided by some of the Hivorian Siddhas, set about "stabilizing the formal relief of the earth's surface", using the knowledge they had acquired in Atlantis. It is these people who build the great megaliths that are scattered near the coasts all over the world, which are not primitive monuments but highly advanced technical instruments. But as long as we do not have a clear idea of what the "sinking of Atlantis" REALLY means, we will not be able to understand the megalithic work of the Cro-Magnons. Perhaps something will become clearer if we consider that what happened WAS NOT A SIMPLE CATACLISM, explicable ONLY by physical causes such as Plato's "seismic" hypothesis or Velikovsky's "aerolite" hypothesis, but the consequence of a terrible war in which the extraterrestrial Siddhas poured all their enormous knowledge. The battlefield was not only the earth's surface, for other, more subtle planes of existence were involved in the conflict. In short, much is unknown, but it should be kept in mind that AFTER the cataclysm the Earth, which is a living organism, had to be RESTORED.

---

1 *From there comes the friendship (hyperborean camaraderie) between whites and mongo-les; friendship that today will have to be discovered and updated: that is the problem faced by the Siddha Anael in Asia, Africa and Latin America.*

in its physiological functionality so that it would continue to be habitable (so that the "kingdoms" of nature would not react "against" man, for example). In this task the Cro-Magnon worked using menhirs, dolmens and cromlechs, and other telluric instruments that will be described later.

It is now worth quoting a page by Louis Charpentier, where he imagines the possible function of the menhirs:

*"Some five or six thousand years ago, the Chinese discovered - and perhaps not only the Chinese - that the human body is the seat of distinct currents of nerve influences, the courses of which lie outside all known anatomical conduits.*

*In the healthy man, these currents - which are two and of opposite nature - are balanced; but if, for one reason or another, external or internal, they become unbalanced, disease sets in and, with it, one or the other microbe.*

*But the Chinese doctors of that time also discovered that it was possible to act on these currents by puncturing some points of their paths by means of needles of silex - nowadays they are metallic -, in order to restore the necessary balance, or to create certain disorders voluntarily. This is the Chinese therapy known as ACUPUNCTURE.*

*Like the human or animal body, the earth is traversed by currents other than magnetic currents, the nature of which is not well known, but which exert their action on the geological layers they pass through and, therefore, on the vegetation.*

*In addition, a few decades ago, agronomists tried - apparently with some success - to activate crops by erecting antennas capable of collecting atmospheric static electricity, which was then distributed to the soil by various means.*

*It is not excluded that the menhir -although the stone is not a good conductor- exerts an action of the same order, especially when it is humid, for example, by means of the "water of the moon", that is, the dew.*

*Then we could think that the menhirs were raised higher or lower, according to the intensity of the telluric current, to establish a beneficial balance.*

*Very interesting agronomic studies could be undertaken along these lines."*

Undoubtedly we are on the right track here. But, as will be seen in the following comments, terrestrial acupuncture is only a secondary objective of megalithic construction.

**B.**

To understand what we are referring to when we speak of the "lithic technology" that the Cro-Magnon applied after the Atlantean cataclysms, we should first consider certain aspects of the human habitat on the earth's surface. But here we will not deal with the ecological habitat, which is dealt with by the natural sciences, but with the PSYCHIC RELATIONSHIPS that man establishes with the ENVIRONMENT he inhabits, and the way in which this habitat has been CHOSEN. To this end, we must define the concept of PSYCHOREGION as "that habitat chosen by man by virtue of a PSYCHICALLY APPRECIABLE TELURICAL QUALITY".

This definition excludes the choice of habitat out of necessity or obligation. Because in his multiple displacements, man USUALLY CHOOSES THE PRECISE PLACE where he will build his dwelling, found a city, elevate his soul to God, etc., motivated by transcendent experiences that surpass the mere physiological need to feed or protect himself. Thus, a PSYCHOREGION is THE CHOSEN PLACE, by excellence, to perform acts of greater or lesser transcendence.

In principle, the psychoregion can be "personal" or "social". We wish to climb a hill; WE CHOSE A CERTAIN ONE, among many others, in the mountain range. This choice was influenced by extremely complex psychological motivations, but above all we must emphasize the INTERACTION between the CHOSEN HILL and the FACT OF CHOOSING, because it is precisely this INTERACTION that turns the preferred hill into a PERSONAL PSYCHO-REGION.

Another person may prefer another hill, but, out of a whole landscape of hills, for me the chosen hill is DIFFERENT, it STANDS OUT in some mysterious way, it wants an enhancement that transforms it into an OBJECT OF APPRECIATION, into a PERSONAL PSYCHOREGION. Personal psychoregions, then, are as many places as are chosen for reasons of telluric interaction, from a "lovers' corner", of strong transit, to a "home" in which one has to live for many years.

On the other hand, a SOCIAL PSYCHOREGION is a site that has been chosen on the basis of community or collective psychological motivations. For example, a place that exerts a certain "charm" on more than one person is a "social psychoregion". The "cave" chosen, among many others, by a tribe as a communitarian habitat, is also a social psychoregion, unless this choice was motivated exclusively by necessity.

In ancient times the sites where cities were erected were chosen for transcendent reasons, of a religious or esoteric order. Today, humanity lives in great cities that are also collective psychoregions because, although the present citizens HAVE NOT CHOSEN the psychoregion, at some point their ancestors have done so when, for certain motivations, they decided that this was the preferred place, the exact site, in which the city MUST BE EARTHED and the FOUNDATION STONE MUST BE LOCATED. It is evident, then, that every city has been at some time a PRIMORDIAL PSYCHOREGION, chosen by the "founders" and that the same must have happened with the "sacred places", on which the religious temples are erected, which were also selected at some primordial time.

In a city with many temples, we choose the one we like, which constitutes, for us, a PERSONAL PSYCHOREGION. But the place where the temple is located has been, at the time of its foundation, a SOCIAL PSYCHOREGION; and it still is, since it is visited by many faithful who feel the same attraction. As usual, we refer only to telluric interactions and discard other important relationships, but of a psychological order, such as that of "closeness" or "remoteness" of the temple; the adoration there of some "invocation" or sacred image; any need or obligation, etc.

Without going into further examples, we can complete this concept by considering that, at present, due to the demographic and material expansion of civilization, it is no longer common to practice the choice of a SOCIAL PSYCHOREGION, although all mankind constantly chooses PERSONAL PSYCHOREGIONS. But in antiquity there was a whole science of telluric selection, and, in fact, the most ancient cities that have come down to us were founded by means of patterns that are today completely unknown. Modern rationalism, as always, provides dogmatic explanations that "History", "Archaeology", etc., rigorously support. In order to elaborate such explanations, the Traditions of the peoples, whose wealth of myths and legends (the "cultural objects" of the superstructures of the historical facts) could surely approximate the truth, are never consulted. On the contrary, a "scientific method" is used to interpret the fact which, this time, is extremely simple:

A rational "manual of procedures" is invented and, consulting its qualifying guidelines, the work of the ancients is "academically" qualified. In this manual, the guidelines for "defense", "food", "water supply", "communications", etc., are considered. If a city, for example, Babylon, was founded "taking these guidelines into account", i.e.: near a river, close to trade routes, on an elevation that dominates the surroundings, etc., then its inhabitants were "almost modern". But if a people made "the mistake" of building their cities in disregard of any of these rules of modern rationalist strategy, if for example they "despised" that impregnable hill and chose to live in the valley, then they were "simply idiots", primitive beings who "ignored everything" about the way in which "a good city should be planned".

Of course, the rationalist obsession, which claimed for centuries that Troy could not be where it really was and which fails to understand why the Maya built cities they never inhabited, does not recognize an important aspect of the problem, which is the choice of psychoregions.

In ancient times, telluric inspection was entrusted to sensitive persons, priests or initiates, who never used rational criteria in this task, but were guided by esoteric knowledge. These people "knew how to choose the right place" according to the needs of the community, which varied in many cases: lasting city, transitory city, camp, fortress, farm, etc. In very ancient times, for any construction, the appropriate site was carefully selected, whether it was a port, a temple or a bridge. Today it seems obvious that first the road was built and then, in the empty places, the bridge was built or the stones were placed for jumping. However, it would be surprising to know how often very large detours were made to cross the river at places that were neither the most beached, nor the closest between banks, but the "psycho-region" pre-dominated over any logical or rational guideline. A river "should not" be crossed anywhere, just as the land "should not" be plowed and cultivated in its entirety; there were zones, NEGATIVE PSYCHOREGIONS, where the telluric influence was harmful and should be carefully avoided. Many of those precautions of the ancients have come down to us (the anthropologist JENSEN calls them "survivals") as additions to myths and legends, but they are taken for meaningless superstitions.

But the truth is that in antiquity the existence of "hostile" places was well known and accepted, which explains many of the "failures" that would have been committed in the choice of useful places, according to the guidelines of the "manual of procedures" of modern rationalists. Because many times a place endowed with all



The obvious advantages, in terms of security and food, had on the other hand the ETHERIC disadvantage of containing a negative psycho-region that effectively prevented settlement because it did not guarantee community welfare. On the contrary, places could be located that were completely unprotected or dangerous, but which represented true earthly paradises for those who ENJOYED their psychoregion. Nothing else, for example, explains the tragedy of Pompeii, built on a slope of the Vesuvius volcano, a city that, despite the earthquake of 1631, was rebuilt at the request of its inhabitants, who could not bear the idea of opening it; and that is why they perished almost entirely sixteen years later, in 79, when a new eruption buried it under the burning lava and ashes.

We will not dwell any longer on a subject that is easy to understand. It only remains for us to add that, in Atlantis, during the Luciferic period, there existed a whole "science of the psychoregions" on the basis of which the Hyperborean Siddhas instructed the viryas on the techniques to be used to "dominate nature" and to reorient themselves strategically. Nature" according to this science is only a sensible aspect, a concrete appearance, of that infinite multiplicity of evolutionary processes that make up the macrostructure of a Manu Age. That is why "mastering nature" means to know how to operate on the evolutionary processes and to achieve independence of the psychoid Archetypes. The "science" that allowed such "mastery of nature" was part of the Acoustic Kabbalah and this, as we have already mentioned, was known only to an elite of hyperborean initiates.

After the cataclysms (the "sinking of Atlantis") the Earth experienced a very great alteration in the functioning of its systems of vital energies and subtle fluids. The contrasts between psychoregions were accentuated to such an extent that the unevenness was easily perceived by man and was often dangerous. To balance the psychoregions and make them habitable to mankind, the Cro-Magnons externally employed their knowledge of the Kába-Acoustics. But such external action, to be effective, must be accompanied by INNER WORK; for humanity (or its ethnic groups) interacts with the psychosphere (the "subtle body") of the Earth, the seat of the psychoid Archetypes, and this relationship can "attenuate" or "excite" the contrasts between psychoregions.

Today the possibility of effecting "collective" control over the environment by employing psychic powers (the "force of will") will be viewed with skepticism; for the advance of the Kaly Yuga (the demographic expansion of "confused" racial elements, the generalized predominance of the animal tendencies of the pasu, etc.) has produced a humanity immersed in a materialistic stupor that prevents it from becoming aware of its mental power and of the power with which this power can be used to control the environment.

could act on the psychoregions. Consequently, modern man is unable to resolve the current disturbances between psychoregions. The Synarchy Strategy has capitalized on this impotence and has launched subversive movements that "denounce the conflict between man and the ecological environment"; but there are indeed real causes that a truly ecological movement should seriously investigate.

Returning to the concept of psychoregion, it is time to ask: what is called psychological interaction between man and the environment? We have already defined it indirectly: there are "bad" places that we call NEGATIVE PSYCHOREGIONS, just as there are also places that have a certain "charm", which we will now call POSITIVE PSYCHOREGIONS. These elementary concepts can be deepened if we define a new concept: PSYCHOPHYSICAL CLIMATE.

Let us remember that a PSYCHORELAND is the "habitat chosen" by man by virtue of a psychically appreciable telluric quality". Now we can add that every psychoregion has its own CLIMATE, which can be defined as "the set of sensory and extrasensory perceptions that impress a man situated in his environment". The concept of "climate" can be applied to both positive and negative prisorregions, personal or social, etc. For example, from the gloomy "feeling of oppression" experienced in a gloomy cave, to the "electrified atmosphere" of a theater hall which at the climax of the drama or tragedy is perceived by the whole audience, there are an infinite number of special "climates" of common knowledge. In order to achieve a clear and comprehensible development of this concept, we will begin by studying the "climates" of the natural psychoregions.

**C.**

There are places in the world that enjoy a particular charm and sometimes their qualities are so intense that, when perceived by many, they transcend borders and gain lasting fame. Who has not heard of an inspiring mountain, a dreamy riverbank, a sweetly murmuring stream, all places recommended as very conducive to meditation or love, or to regain lost health or even to inquire into the future? Generally it is the sensitive spirits, musicians or poets, who express in popular language these geographical qualities, contributing to increase their fame.

This is a case of DEEP PSYCHOLOGY, the understanding of which is usually facilitated by establishing analogies with phenomena of physics. That is why we speak of PSYCHOPHYSICAL CLIMATE, although it would be more appropriate to refer to MICROCLIMATE, i.e., TO THE CONDITIONS OF THE CLIMATE IN A LIMITED SPACE. For example, what

What we mean when we say that a psychoregion possesses a particular MICROCLIMATE: that in that psychoregion a different psychological state is experienced from that which would be experienced elsewhere, even in the immediate vicinity. But such a psychological state does not respond only to sensory perceptions, i.e.: visual, auditory, olfactory, etc., but also involves other planes of being, other regions of the soul, whose fiber is not easily affected in ordinary life. It is as if the place, its microclimate, INDUCED in man a totalizing force that, by dissolving perceptions and sensations, transports him to the UNDIFFERENTIATED or unconscious. And this regression to the primordial states of consciousness, far from constituting a passive attitude on the part of the one who experiences it, generates ACTIVE PARTICIPATION between man and the microclimate. The AWARENESS OF EXPERIENCING something special, the ecstasy, is precisely the effect of ACTIVE PARTICIPATION.

We have already mentioned on various occasions the concept of PSYCHOSPHERE, which alludes to a "field" that surrounds the Earth and interpenetrates with all points of inner space. Such a field is equivalent to what in the Hindu Science of Breath is called the TERRESTRIAL GLOBE OF AKASA, that is, that adon- sphere where the Manu Archetypes are deposited, which we have called "psycho- deos", and, on a lower plane than these, the "akashic records", which are nothing more than the astral impression of their evolutionary unfolding in matter. This field is also one of the ten "Vestures" or "Veils" of the Demiurge Jehovah-Satan, "The Ancient of Days", which are named in the Hebrew Kabbalah.

In the "field" of the Psychosphere takes place the UNIVER-SAL COLLECTIVE UNCONSCIOUSNESS, where the psychoid Archetypes lie, and this interacts with the PERSONAL COLLECTIVE UNCONSCIOUSNESS of each individual (pasu or lost virya). In this way, human evolution is connected with the development of the Planetary Archetype, since the Psychosphere is the "substratum" of the terrestrial physiology, the "subtle body" that serves as a "vital nervous system" constituted by a complex network of theuric energies with millions of vortexes or "chakras" and distribution channels or "naddis", etc.

In book 4 these concepts will be duly defined and substantiated. The important thing now is to understand that a certain part of the human psyche, called the "personal unconscious", PARTICIPATES IN THE UNIVERSAL COLLECTIVE UNCONSCIOUSNESS OR PSYCHOSPHERE. In fact, the pasu is absolutely linked to

**Rosario**

the Psychosphere and only the virya can transcend the archetypal determination exercised by the unconscious.

The collective psychoid collective consciousness -through the personal collective unconscious- over the ordinary consciousness. That transcendence, that awakening, that liberation that is achieved after traveling the path of the return to the origin, is a subject that we have already dealt with elsewhere.

We are now in a position to define a PSYCHOID ISLAND, starting from the concept of PSYCHOREGION already studied: A PSYCHOID ISLAND IS THE COUNTERPARTS OF A PSYCHOREGION IN THE FIELD OF PSYCHOSPHERE.

These three concepts should not give rise to confusion. To avoid misunderstandings, let us note that, inversely, A PSYCHOREGION IS THE PROJECTION OF A PSYCHOPHYCHOID ISLAND IN A DETERMINED GEOGRAPHIC AREA. From this point of view

From this point of view, it can be affirmed that A PSYCHOID ISLAND IS THE ARCHITECTURE OF A PSYCHOPHYCHO-REGION. It is thus understood that we have previously needed to allude to the concept of "Psychosphere" only to define the sphere of existence of the "psychoid islands".

In previous sections we raised the distinction between "natural fact" and "cultural fact". Of the latter we then said that it was "the form" in which a psychoid archetype is concretized as it evolves towards its entelechy; but since the cultural fact is "essentially structural", we called the structure that supports this form "superstructure". We also study in what way the superstructure of the cultural fact "captures" anyone who establishes a cognitive relation with it, incorporating him as the subject of its drama: with its greatest potency the psychoid Archetype of the cultural fact tries to unfold through the human subject, "capturing" and externalizing its own cultural structure.

We can apply these concepts to explain the origin of that ACTIVE PARTICIPATION between man and the microclimate that we mentioned recently: BY BEING ATTRACTED TO A PSYCHOREGION, MAN "ACTIVELY PARTICIPATES IN ITS MICROCLIMATE" BECAUSE HE HAS BEEN CAPTURED BY THE MICROCLIMATE. IN WHICH THE PSYCHOID ISLAND UNFOLDS. There is not yet a cultural fact per se, BUT EVERY CULTURAL FACT BEGINS WITH THE "CHOICE" OF A PSYCHOREGION. We can say, to give more clarity to the matter, that a psychoid island operates as the "frame" or "framing" in which every cultural fact must take place. Therefore, when a psychoid island captures man in the microclimate of his psychoregion, BY THAT FACT ALONE the propitious framework is arranged for the psychoid Archetypes, in a "Karmic reaction", to unfold through a superstructure which now includes man and the psychoregion as component elements and whose dramatic form is called: "cultural fact".

The Archetypes that we call "psychoid islands" evolve concretely in the psychoregions, and these are EXCLUSIVELY GEOGRAPHIC spheres; the "micro-climate" is the natural structure, FOR MAN, that supports the psychoregion. Hence, the "micro-climate of the psychoregion" is equivalent, in another degree, to the "superstructure of the cultural fact": both are expressions of the psychoid Archetypes; the first is of a "psychoid island"; and the second, of a "Manu Archetype".

An Archetype can be "known", that is, conscientialized, by means of the DESCRIPTION of one of the CONCRETE FORMS that it adopts during its evolution. In this sense we can affirm that every psychoregion is a CONCRETE FORM that the corresponding psychoid island adopts during its evolution and, therefore, EVERY PSYCHOREGION IS A "NATURAL DESCRIPTION" OF ITS PSYCHOID ISLAND. See understands then the importance that would have, for a Psychosocial Strategy, the possibility of knowing and distinguishing the psychoregions; but, does such a possibility exist? Yes; because the psychoregions, as GEOGRAPHIC PROJECTIONS of psychoid Archetypes, ARE GRAPHICALLY REPRESENTABLE. Properly trained sensitive persons, initiated in the Hyperborean Wisdom, can draw on a map the CONTOUR of the psychoregions or represent in a "maquette" the surface in relief. In the SS, for example, there was even a corps of trained officials to draw the polygon of any psychoregion in Europe.

**D.**

Let us now return to the distinction between "natural psychoregion" and "social psychoregion".

A natural psychoregion is a place made by the Demiurge's own hand, that is, where a "psychoid island" Archetype evolves, such as a country, grotto, abyss, river, mountain, etc., all places where a particular microclimate can be perceived.

A social psychoregion is, on the other hand, a place chosen by man to establish his habitat, build villages, temples, gardens or palaces, and whose "natural" character has been modified to adapt it to community purposes.

It is evident that every place of the second case has been, before the intervention of man, a place of the first case. It is worth asking: can ANY PLACE serve, by means of its modification or formal alteration, to endow it with a

microclimate suited to human needs: No. It is necessary to choose the site carefully. It is necessary to choose the site carefully. As we saw in the story of Nimrod, The Defeated, it can sometimes take years to locate a suitable site, and that is if you have the people trained to READ the descriptions of the psychoid islands in nature.

And yet, in spite of such complexity, the white Cro-Magnon "stone sages" adapted psychoregions all over the world so that they could be inhabited by man. After the last Atlantean cataclysm, they "repaired" the terrestrial nervous system, making the strategic reorientation of the viryas possible AGAIN. Because, although the megalithic constructions are related to the telluric energy currents, this comes only from a FUNCTIONAL ASPECT of them and does not constitute, far from it, "the motive" of their manufacture, as Louis Charpentier and other followers of Druidism put it. It was not a matter of practicing an "earthly acupuncture" but of conducting oneself according to a Hyper-Borean Strategy: this is the key to interpret the attitude of the Cro-Magnon builders.

Today the Synarchy is trying to erase in any way whatsoever the traces of the Cosmic War, and its tactic, in this sense, consists in denying any warlike determination to the peoples of prehistory. It will thus be proved that all the esoteric authors of the Synarchy, theosophists, Rosicrucians, Masons, Martinists, etc., are PACIFIC ULTRANTS who blindly affirm that "the survivors of Atlantis were founders of civilizations" and bring "as proof" the Mayan, Sumerian, Egyptian, etc., cultures, without explaining the lapse of millions of years that separate them from that cataclysm.

To get closer to the truth, and to avoid synarchic disinformation, let us ask ourselves for a moment, what is the most likely behavior that the survivors of a civilization that has succumbed and disappeared as a result of a total war would adopt: they would certainly not behave ONLY as founders of civilizations ...

In reality, such survivors would maintain a PERMANENT STATE OF ALERT and would only conduct themselves according to MILITARY GUIDELINES, both for moving and camping and, even if they tried to save elements of their lost civilization, THAT WOULD NOT BE, of course, THE MAIN MOTIVE WHICH WOULD DETERMINE THEIR ACTIONS. We have a very handy example in those Japanese who lived for more than twenty years in the Pacific islands after the end of the Second War: although they built themselves cultural objects necessary to survive or live, such as a hut, a hook, or a go game, and although they had transmitted part of their knowledge to the aborigines "civilizing" them, NONE of them had been able to "civilize" them.

OF THESE MOTIVES DETERMINED THEIR ACTIONS; on the contrary, when they were found, it was proved that the soldiers had not forgotten the war AT ANY TIME, always maintaining a PERMANENT STATE OF ALERTNESS and conducting themselves, both for moving and camping, according to MILITARY GUIDELINES; an example of this was the correct functioning of their weapons, which they had lubricated and kept in good condition and, fundamentally, the CONSTANT RESPECT FOR THE MILITARY GRADE - a sergeant in 1945 was still a sergeant in 1960 - which reveals a whole universe of honor and martial virtues.

No doubt, this is the attitude of those who survive a total war AND HAVE NOT SURVIVED: EVERY MOVEMENT, EVERY ACTION, IS TACTICAL AND, THEREFORE, MUST BE EXECUTED IN ACCORDANCE WITH THE PRINCIPLES OF WAR. BUT ALL TACTICS, IN TURN, MUST BE PLANNED WITHIN THE FRAMEWORK OF THE OVERALL STRATEGY,

That is why the Cro-Magnons moved and acted according to the tactics of the Hyperborean Wisdom and their ACTS OF WAR, be they menhirs, dolmens or cromlechs, obeyed the objectives of the General Strategy of the Siddhas.

The main objective of the Hyperborean Strategy is the "return to the origin" and, therefore, a dolmen, for example, has to be used for that purpose MAINLY; and then to "listen to the music of the spheres" or "fix the telluric currents" as Druidism pre-directs. There is in all this a great secret that obliges us, in order not to betray it, to use symbolic language. Let us say, then, that WHEN THE MAIN OBJECTIVE OF THE HYPERBorean STRATEGY IS EFFECTIVELY ACHIEVED, VIRYAS DISAPPEAR FROM HISTORY. We cannot add more.

Thus, it follows that every successful war action carried out by hyperborean viryas, AFTER THE TOTAL WAR, culminates in the DISAPPEARANCE OF ITS PROTAGONISTS. BUT THE STONE WEAPONS ALWAYS REMAIN, EVEN IF THEY CANNOT BE USED AGAIN IN THE SAME WAY AS THEY WERE USED IN THE PAST. THE BUILDERS OF THE MEGALITHS. Louis Charpentier has discovered that, suggestively, the megaliths of France are distributed on an enormous spiral that covers the whole country; he has also verified that, from time immemorial, there is a whole esoteric migration of people who, like a gigantic goose game, go on pilgrimage along the spiral path seeking a sort of initiation to the mysteries of stone construction ("masonry")<sup>1</sup>. Naturally, something that Charpentier is unaware of, such migration begins AFTER the stone constructions; for THE BUILDERS DISAPPEARED WHEN THE

---

1 *LOUIS CHARPENTIER: The Giants - Ed. Plaza y Janés.*



LAST STONE OF THE CENTER OF THE SPIRAL OR "EYE". Those who arrive later, and do not know the secret of the stone or lack the blood purity to plan a Hyperborean Strategy, HAVE ONLY THE ALTERNATIVE TO PURIFY THEMSELVES BY FOLLOWING THE STONE ROUTE OF THE SIDDHAS. As THE ORIGIN IS COMMON TO In the case of ALL HYPERBORNE LINES, it is possible that by following a path to the origin, OPENED BY OTHER VIRYAS, it is possible to RECOGNIZE THE SECRET and thus be able to consider one's own Strategy.

To neutralize these stone weapons and the possibility of "strategic orientation" they offer, the Druids have been engaged for centuries in a magical blockade, engraving signs or practicing rituals aimed at altering the surrounding psychoregions. But, since they infiltrated the Catholic Church, their actions have been tremendously effective because, after destroying the lithic weapons, they erected other stone constructions specially designed, according to the principles of the acoustic Kabbalah, to achieve the strategic goals of the Synarchy. We will return to this later.

#### E.

We will now highlight an element that is closely linked to the transit through the world of the Cro-Magnon whites. If on a map we indicate the world distribution of the megaliths - which will undoubtedly be incomplete because many have been destroyed - and on another identical map we mark the places where the ancient sign of the SWASTIKA has been found, we will see that the areas of dispersion are identical.

Although the Swastika is held by peoples who, although inhabiting the megalithic places, have not been the builders of them, this fact does not invalidate the argument; for it is precisely these peoples of inferior culture who have picked up or discovered the Swastika from the megalithic construction; FOR, IN A CERTAIN SENSE, BOTH ARE ONE AND THE SAME THING. We have already stated that the megalithic constructions are TACTICAL WEAPONS to be used within the framework of a Hyperborean Strategy, and that the objective of such a Strategy is "the return to the origin". To understand our previous statement, we need only remember that in every strategic action TOWARDS THE ORIGIN, the Gral, reflection of the origin, must intervene. But the Gral is supported by the Golden Rune and in it is engraved the Sign of the Origin, FROM WHICH IS DERIVED, BY DEFORMATIONS AND MUTILATIONS, THE RUNE SWÁSTIKA. Hence, a lithic construction, designed to move a warrior community "towards the origin", makes it possible for another community, more impure or confused, to perceive the Sign of the Origin and "worship" or consider the rune "sacred".

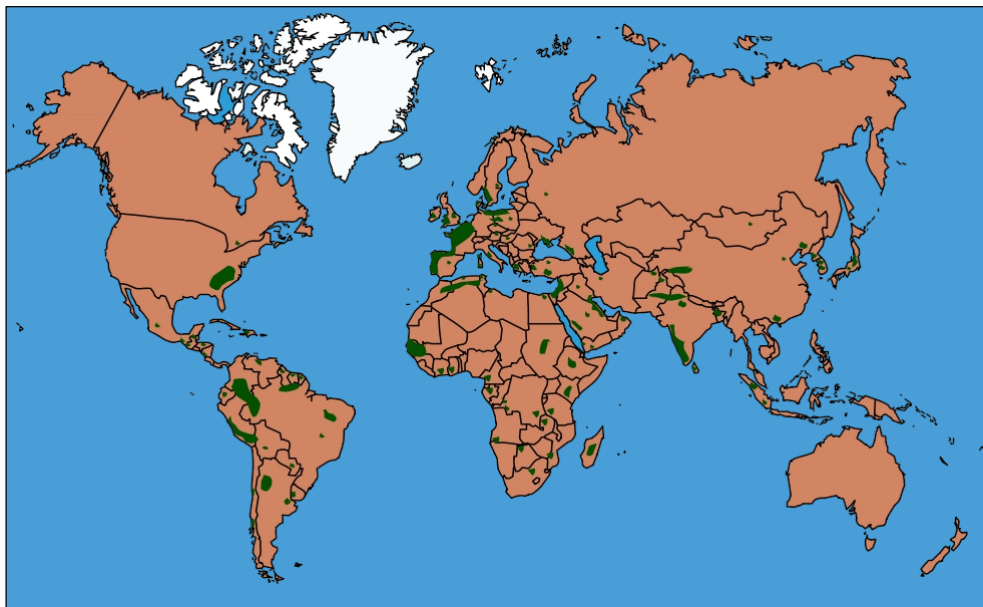

Worldwide distribution of megalithic constructions Fig. 7

Swástika.

But the Swastika, which is derived from the Sign of Origin, does not itself represent a "solar sign" despite having been rationalized as such by decadent sacer- dotes who also identified it with "life", "movement", "reincarnation", "the pole", etc. In Antiquity, the Swastika WAS A HYPERBorean SYMBOL FOR FIRE AND BLOOD, WHEN BOTH SUBSTANCES ARE ONE.

AND THE SAME THING. Today fire is COMBUSTION, the optical illusion of a chemical process of change of state of matter, and blood a PLASMATIC LIQUID. But the Hyperborean Wisdom teaches that PURE BLOOD AND FIRE have a common nature, a knowledge that is at the basis of the acoustic Kabbalah used by the Cro-Magnon to DOMINATE the currents of telluric energy. He who can SEE telluric energy finds it similar to a fiery vapor; but blood is also SEEN in the same way: as a fiery vapor; and by such analogy it has been spoken for millennia of "blood of the Earth"; and even, because, in watercourses, rivers and streams, the circulation of telluric energy is greater, water has been identified as "terrestrial blood".

There is therefore a lost knowledge about Swastika that only the Aryans of India, the Germanic people of Frisia and Saxony, and perhaps the Mayas of Yucatan, have preserved in a distorted form until modern times. There is an ancient Sanskrit word for fire that highlights the hyperborean "memory" of the identity we have been pointing out: it is the word PUR; which, besides meaning "fire", constitutes the root of PURA, a quality of blood. Indeed, in the Vedas we constantly read that the blood of kings, warriors or priests, that is, of members of the higher castes, is PURE, and therefore igneous. Blood and Fue- go were named in ancient Sanskrit, then, with a single word, PUR, which also meant PURE, undisputed quality of AGNI, the God of Fire, and of the blood of the legendary heroes or Siddhas.

The Germans also preserved part of this knowledge by using the Swastika as a RUNE, that is, as a magic word, an element of the acoustic Kabbalah.

The acoustic Kabbalah is based on the principle that every form is supported by a word, which is also an Archetype, which was pronounced in the

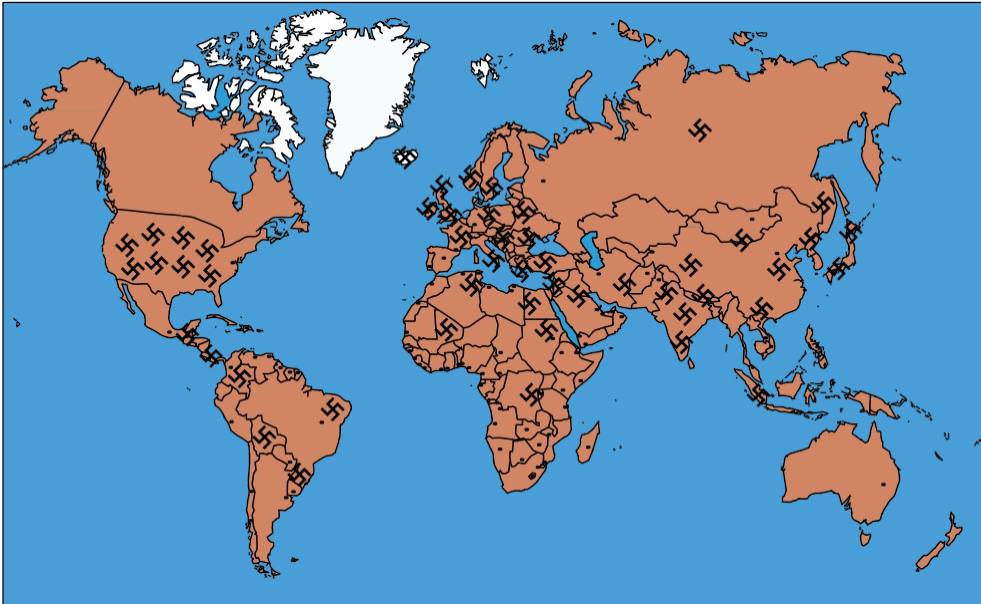

Worldwide Distribution of the Sign of Origin or "RUNE  
SWASTIKA" Fig. 8

beginning of the Drama by the Creator Logos, that is: the Verb aspect of the Demiurge. Knowing the acoustic Kabbalah means a STRATEGIC ADVANTAGE that allows, for example, to "adapt" the environment, the Valplads, to serve the purposes of a Hyperborean Strategy by diminishing the satanic pressure of Maya, the illusion of the real.

That is why those who used as letters the Swastika and other symbols of the acoustic Kabbalah, were undoubtedly possessing a strategic advantage over other peoples already synarchized. An advantage that today the Germans lost because they must submit to the rules of a Judaized, Satanist and synarchic world, but that nevertheless does not represent an evil as great as that which other Hyperborean peoples have had to endure, such as the Aztecs, for example, who not only lost their alphabet of Kabbalistic symbols, but whose culture was destroyed and who even tried to exterminate their race.

**F.**

We said that the Cro-Magnon sowed the world of megaliths and we add, as an illustrative fact, that the Swastika appears in the same places where the lithic weapons were erected. We know that on this subject an infinity of nonsensical opinions have been expressed; nevertheless, we cannot avoid the affirmations of certain profane commentators, very promoted lately<sup>1</sup>, who, after observing that the megalithic constructions are distributed predominantly near the coasts of rivers and seas, draw the conclusion that "the builders came from the sea", or were simply a "seafaring race". This notion WE DISCLAIM IMMEDIATELY and affirm, on the other hand, that the work of the LEADERS of lithic art was much more extensive than is usually supposed, since it included THE ENTIRE SURFACE of the continents; and that, since we do not know what this work consisted of, we arrive at erroneous and absurd conclusions.

The key is in the acoustic Kabbalah, which includes the use of LYTHIC RESONATORS - menhirs and dolmens - but also FORMAL DEVICES - such as the cromlech, the labyrinth, the profile of large rocks and mountains, the well and the cavern, etc., - THAT WORK IN A DESCRIPTIVE WAY ON THE PSYCHOID ARCHETYPES.

There are many caves that have been artificially modified to SERVE certain purposes, when they are not entirely artificial; and numerous wells, all over the world, record human elaboration. Also petroglyphs and figures

---

1 *"SUSPICIOUSLY" PROMOTED.*

In Peru, at the Marcahuasi site, located on a small Andean plateau at an altitude of 4,000 meters above sea level, one can visit today an authentic Cro-Magnon workshop-school, where anyone can find a Cro-Magnon workshop-school; there, in a small Andean plateau at an altitude of 4,000 meters above sea level, one can visit today an authentic Cro-Magnon workshop-school; there, anyone can find a Cro-Magnon workshop-school. In Peru, in the site of Marcahuasi, located on a small Andean plateau at an altitude of four thousand meters, you can visit today an authentic Cro-Magnon workshop-school; there anyone can contemplate "in situ" a whole arsenal of tactical lithic weapons and verify, if you have "good eyesight", that these exceed by their overwhelming diversity to the best known of the menhir, the dolmen or the wall.

## G.

We have already referred to the modifications that the Cro-Magnons made in many psychoregions, transforming them from "natural" to "social" or suitable for the viryas to inhabit and "strategically reorient". But we also mention that in many cases the social psychoregions were altered again by the Druids, with the purpose of readapting them for the Strategy of the Synarchy; for example it is worth remembering that many of the great temples of the "modern" Catholic, Muslim, Buddhist religions, etc., have been built OVER ancient "pagan temples", that is: in places that were venerated since the most remote antiquity and in whose center there was a menhir, a dolmen, a cromlech, etc. Let us now explain the nature of this SYNARCHIC CONTRAOFENSIVE.

The Druids infiltrate the Benedictine Order from the 4th century onwards and then, from the Cistercians and Cluny, they launch the Order of the Temple in the first and most terrible offensive aimed at establishing the World Government of the Synarchy. In studying Strategy A2 we will comment on this synarchic plan, and explain the reasons for its failure. The important thing is that, for such a plan to succeed, the religious psycho-regions of Europe had to be prepared centuries in advance so that their micro-climates would capture the "believers" and incorporate them into the process of the Jesus-Christ Archetype.

For this purpose the Druids counted on the acoustic Kabbalah, in which they were masters, and on the numeral Kabbalah, which the Jewish sages gladly placed at their disposal; combining this formidable knowledge they developed a technique of psychosocial control based on the archetypal resonance of enormous stone structures. The concrete expression of this work is the Gothic cathedral that "appears", as everyone knows, in the 11th century. This gigantic construction is a lithic instrument finely calibrated to generate a religious microclimate, capable of overwhelming the parishioner with its grandeur and of suggesting to him an

**Nimrod from  
Rosario**

attitude of respect and devotion. Nothing

More than that, the Jesus-Christ Archetype needs to effect the capture, transforming the microclimate into superstructure and the religious psychoregion into a cultural fact! But the most admirable thing about such an infernal machine - and although this statement scandalizes geneticists, we will say it anyway - is that, once the capture has been effected, it "modulates" the genetic information of the believer, making the Jesus-Christ Archetype hereditary, that is, genetically Judaizing the unwary; This is achieved because the Jesus-Christ Archetype, which is psychoid, that is, belonging to the universal collective unconscious, is introduced and shaped in the personal collective unconscious by the action of the cathedral, which implies a chromosomatic modification IN ALL THE CELLS OF THE HUMAN ANATOMICAL STRUCTURE.

They are thus the cathedrals: MACHINES FOR PSYCHICALLY (AND GENETICALLY) PROGRAMMING THE POPULATION FOR THE PURPOSE OF CONFORMING A JUDAIC HUMAN TYPE, ACTING ON GENETIC INHERITANCE BY THE TRANSMISSION OF INDUCED SYMBOLIC CHARACTERISTICS.

From the point of view of the Hyperborean Wisdom, the construction of cathedrals -and other monuments that we do not mention here for the sake of brevity- is an authentic tactic of Psychosocial Strategy put into practice by the White Hierarchy of Chang Shambala to favor the advent of the Universal Synarchy. Concerning the FUNCTION of the cathedrals, both the Druid Fulcanelli and the Celticist Louis Charpentier, and many other authors of similar synarchic affiliation, claim that they are "books of stone" destined to perpetuate an "occult knowledge" - here it would be Alchemy - which, due to the "reigning obscurantism", cannot be exposed even by initiatory organizations. It is hard to believe that such idiocies can be said in good faith! And we would be tempted to doubt the rational judgment of those who utter them, IF WE WERE NOT AWARE THAT THERE IS A SYNARCHICAL STRATEGY AND THAT THEY ARE ITS AGENTS.

To make things clear, let us remember that a similar conspiracy occurs with the pyramids of Egypt, in which all the "esoteric" authors agree in affirming that, for example, "Cheops is a book of stone, where the Egyptian knowledge has been poured to perpetuate it through time". On what do they base this affirmation: on the perfect geographic orientation of the constructions - pyramids and cathedrals - and on the intervention of very exact and striking NUMBERS, extracted from Physics or Astronomy, in the dimensions of the monument.

Let us now see what is the truth that the Sinarchy tries to hide or conceal with absurd theories: pyramids, cathedrals and, in general, all temples built on the basis of cabalistic principles ARE FUNCTIONAL MACHINES.

NALS, built to operate collectively on the public. Ask yourself the following question: what machine does not involve measurements and dimensions linked to the laws of nature that it is intended to govern and exploit? To infer from this that the machine is a book into which knowledge of nature has been poured, destined to be read in the future, is a totally unrealistic idea.

A machine is built to be used in the present and in the immediate future, or to work while it has a useful life, but it is never built thinking about what will happen thousands of years later. Of course, if such a machine crosses the millennia and is contemplated by beings who ignore its FUNCTIONAL PURPOSE, it would not be strange that they would mistakenly reason that it is "a book" and even "read messages" in it. Think, to give an extremely simple example, of some men of the future who, ignorant of everything about our civilization, would find THE SQUARE OF A WALL CLOCK ONE METER IN DIAMETER. And that from their  
If they were to conclude that it is a "book" made for future generations by ancient beings who knew the longitude of the terrestrial meridian, counted up to twelve, probably worshipped the circle, perhaps the Sun, were in the Bronze Age, etc. All these deductions are logical, but they do NOT INDICATE ANYTHING ABOUT THE CLOCK, nor about the FUNCTIONAL PURPOSE for which it was designed.

It is necessary to understand, then, that cathedrals and other similar monuments must be considered in their STRUCTURAL TOTALITY, attending to the FUNCTION for which they were designed. And if we do not know what that function is, it is BETTER TO BE SILENT because otherwise we collaborate with the Synarchic Strategy that consists in fomenting confusion in everything that is related to Chang Shamba- la and his demonic plans.

#### **H.**

Closely connected to this theme, there is another synarchical tactic that we will now warn about. When people speak of "Middle Ages" and "Renaissance" they often make the deliberate mistake of asserting that indeed "a kind of gulf" separates the two epochs. It would seem, according to the historians of the Synarchy, that the Middle Ages were a time of impenetrable darkness whose blackness was abruptly dispelled by Renaissance humanism. The Renaissance would thus seem to have arisen by spontaneous generation, totally divorced from the epoch it came to "surpass". But, however well one looks at the matter, one discovers again, behind such opinions, the synarchic tactic.



We will say it again: the Demiurge, his Great Breath, impels matter to EVOLVE following the formal order of his Plans, or Manu Archetypes. The Law of Evolution thus governs all orders of existence, including human societies. But the White Hierarchy of Chang Shambhala usually hastens this social EVOLUTION by means of an alteration called REVOLUTION, which is also expressed by a precise law which consists in posing a dialectical opposition to the system which it seeks to REVOLUTIONIZE. That is why it should not be surprising that, after every revolution, revolutionaries deny and devalue the previous order: it is pure synarchic tactics, which can be verified by observing the French, Russian, Cuban, etc., Revolutions, where the dialectical clash and the denial, on the part of the new order, of all value to the displaced order is evident. This synarchic tactic is very evident and would not require further comment ... if it were not that the Renaissance does not appear in History as a "revolution".

However, overlooking the qualifications, we discover at the heart of the Renaissance change the same Synarchical Strategy that directs the great revolutions of History; and with it the negation of the "previous epoch" which is labeled "obscurantist". But, since we rule out its natural or spontaneous character, we must ask: who launches a revolution as vast as "the Renaissance"? Because every revolution registers, behind the obvious protagonists, a hierarchy of "gray brains" who PLAN AND DIRECT the movement. The violent aspect is only the culmination of a long subversive work carried out by professionals, "agitators and revolutionaries", who have also been "agitated" by hidden forces that rarely show themselves to the public light. We know that the Synarchy lies behind these powerful movements; but in the case of the Renaissance this is not always clear enough, and we will say why: because the Renaissance was a CULTURAL REVOLUTION, NOT A POLITICAL REVOLUTION like the violent revolutions we are accustomed to consider.

The REACTION to such a revolution was called: CATARS AND FEDERIC II HOHENSTAU-FFEN; and it was fiercely repressed. And note that if we speak of a reaction in the thirteenth century to a revolution occurring in the fifteenth century, it is because we admit that in the thirteenth century the motivations that would trigger the revolution of the Renaissance were already in sight; motivations that the Druids and their henchmen had incubated for eight hundred years. And the greatest of these motivations, the most evident, was the cathedrals, so effective in their cultural revolutionary objective, so splendid in their structural perfection, but, above all, so grandiose in the face of human smallness, that it was very difficult to react against them. But this inhibition was, undoubtedly, another important synarchic objective.

We repeat it for the last time: it is a mistake to believe that the Renaissance was truly a reaction against the culture of the Middle Ages. It was the Middle Ages itself, its HIDDEN FORCES, which generated the Renaissance, preparing it for centuries, acting on the masses by means of psychosocial tactics, among which - for they are by no means the only ones - are the cathedrals we have been mentioning.

But, surely, we are tempted to ask: without the cathedrals would there have been a Renaissance: WE BELIEVE NOT. This answer may give an idea of the importance we attribute to the collective influence of the gigantic stone machines and to the science that made it possible to design them: the acoustic Kabbalah.

## **10.**

Whoever has read the previous nine paragraphs will have already understood that we reject "the SOCIO-CULTURAL point of view that recognizes man as an active agent and the Earth as a passive subject, (which) is now generally accepted (by geographers)"<sup>1</sup>, because it implies a false concept of "free will" that man, slave of Jehovah-Satan, in reality does not have. On the contrary, for us, and according to the Hyperborean Wisdom, man is the SUBJECT of a drama (the process of the psychoid Archetypes) that unfolds in the theater of a psychoregion of the Earth, which behaves as an ACTIVE AGENT that captures him and integrates him into the superstructure of cultural facts.

When we criticized the "historical ages" and "culture", we showed that the lost pasu or virya is, in general, a prisoner of the cultural facts; but later, when defining the "psychoregions", we explained that these constitute the primary sphere in which the process of the cultural fact begins; "man" and "psychoregion" would thus seem to be the fundamental and sufficient elements to understand the drama of human life. However, this is not so, for "psychoregion", as we define it, is a SPATIAL concept, which tells us nothing about the TEMPORAL dimension of the drama. To complete this aspect, the Hyperborean Wisdom brings the complementary concept of GEOCRONY, from which the Kaly Yuga can be defined.

It is easy to understand that the process of the psychoid Archetypes CANNOT BE THE SAME IN DIFFERENT PSYCHOREGIONS. For example, the Lady Archetype is de-

---

1 *JAN M. BROEK - GEOGRAPHY - U.T.H.E.A. HANDBOOK - Mexico*

If the psycho-region where the drama unfolds is, for example, Fulano's "native village", then Fulano will be able to project his "impossible love" on one of the village women and sublimate his sexual energy with which the Lady Archetype feeds; but if the psycho-region is, for example, a "desert island", the projection will not materialize "outside" and the process will take another course. In this extremely simple example, but which exemplifies many other cases, we see that VARYING THE PSYCHOROREGION WILL VARY THE PROCESS (because, naturally, the superstructure of the cultural fact varies).

But this variation of the process is of what nature; because we do not say that the process "will not take place", but simply that "when changing the psychoregion, the process varies". The answer is: when changing psychoregion the process varies TEMPORARILY; or, in other words: if a man, captured and integrated into the superstructure of a cultural fact, changes psychoregion, THE PROCESS OF HIS DRAMA MAY BE FASTER OR SLOWER, ACCORDING TO THE CHARACTER GEOCRORRÓ-  
THE GEOGRAPHICAL LOCATION OF THE SITE IS NOW UNDERSTOOD TO BE STRATEGICALLY IMPORTANT. The strategic importance of the geographical location of the viryas can now be understood.

There is therefore a relationship between every psychoregion and the temporality that the process of the psychoid Archetypes takes WHEN THEY DEPLOY IN THEIR AREA. But the different psychoid Archetypes compose an infinite set, and EACH OF THEM PRESENTS A DIFFERENT TIME OF EVOLUTION IN EACH PSYCHOREGION.

PARTICULAR. That is why it is not possible to take into consideration ANY PARTICULAR ARCHETYPE to refer to the temporal relationship between "psychoregions" and "cultural facts" or, in the psychosphere, between "psychoid island" and "psychoid archetype". The concept of "geochrony" is defined by the Hyperborean Wisdom following an inverse path: IT DOES NOT REFER TO THE PROJECTION OF A PSYCHOID ARCHETYPE BUT TO A BLOOD REMEMBRANCE; TO THE REMEMBRANCE OF LILLITH "OUTSIDE", THAT IS TO KALY. In effect: "GEOCRONY IS THE CAPACITY OF A PSYCHORRHONY TO DARKEN THE IMAGE OF KALY".

What does this have to do with time? That, INVERSELY, a psychoregion where it is not possible to perceive Kaly is a place where MAXIMUM TIME SYNCHRONIZATION can occur between the biological rhythms of the microcosm and the Time of the macrocosm, which is an expression of the immanent flow of the Consciousness of the Demiurge. Therefore, geochrony gives a NEGATIVE indication of the possibilities offered by a psychoregion to achieve STRATEGIC ORIENTATION or, in other words: the higher the geochronal index of a

psychoregion, the lower the possibility of strategic orientation.

Within the Hyperborean Wisdom there is a science that studies everything related to the psycho-regions and their geo-chronic relationship with man: it is the CHOROLOGY<sup>1</sup> ESO-TERRICA. The Thulegesellschaft had an important "closed circle" specialized in chorological studies, which, after 1936, passed to the Ahnenerbe Institute of the SS. And it was the chorological experts of the Ahnenerbe Institute who carried out a worldwide survey of geochronological indices and discovered that A TRUE ROUTE OF FOGS COULD BE LOCATED - OR CHOROGRAPHED - ON THE EARTH SURFACE (Fig. 9).

This "Route" is the current expression of the so-called "Kaly Yuga" and demonstrates, as we anticipated elsewhere, that its influence is not uniform throughout the Earth, as would be expected from a simple "Historical Age", but varies in "intensity" according to the latitude considered. The "intensity" that varies is that of the "tinie- blas" that impede the perception of Kaly and that is why, as one "advances" in the direction of the Route of the Kaly Yuga, the loss of strategic orientation is greater and greater<sup>2</sup>.

The Kaly Yuga Route has its lowest intensity at the South Pole and its highest intensity at the North Pole. From the South Pole it advances over Antarctica, forming part of the Antarctic Peninsula and several island archipelagos "the omega of the left hand"<sup>3</sup>. These islands, including mainly the Orkneys, Sandwich and Georgia, are an outer appendage of the Andean Cordillera, which sinks under the Atlantic Ocean to reappear in Antarctica as the "Antarctic Ridge".

---

1 *CHOROLOGY, from the Greek root COROS = PLACE, literally means "study of the relations between things and people that give character to places", in the theory of the 19th century German geographer FERDINAND VON RICHTHOFFEN. But Esoteric Co- rology is concerned with studying not just any places but "psycho-regions" and establishing specifically "geochronic" relationships between them and the man affected by his environment. Esoteric Chorology is, properly speaking, "applied Hyperborean Wisdom". The same can be said of another complementary science: CHOROGRAPHY, which studies and develops techniques to represent psychoregions in maps or "maps".*

2 *This does not mean that the Kaly Yuga acts ONLY on the Path. The whole Earth is subject to its influence, but FOR MAN, due to the geochronological action of the psychoregions, the INTENSITY OF THE DARKNESS is overwhelmingly greater WITHIN THE ROUTE.*

3 *It is understood that we refer to the "left hand" of Sanat Kumara or Jehovah-Satanas.*

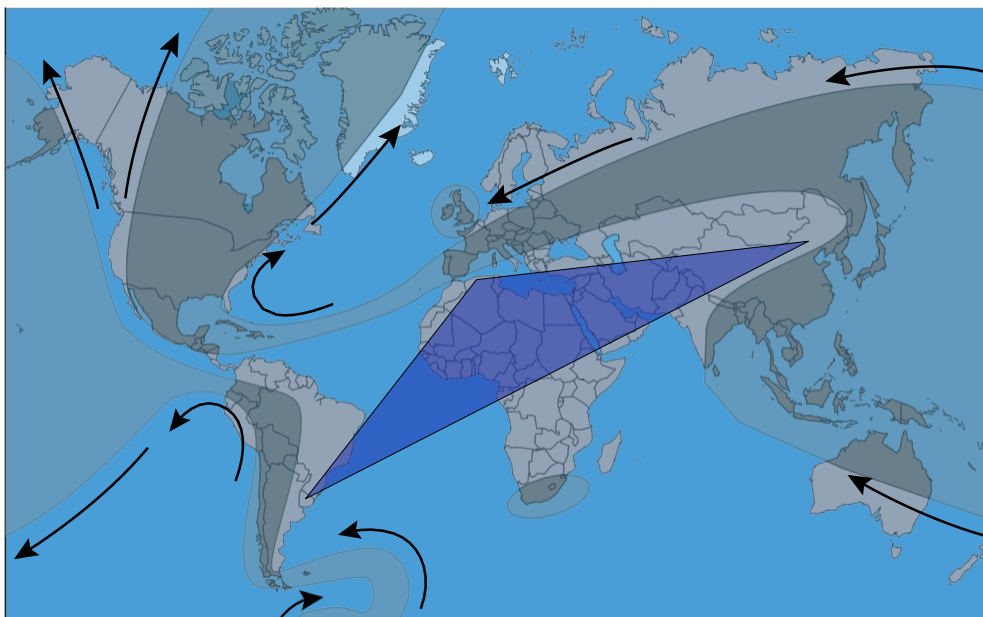

The Secret Route of the Kaly Yuga and the Triangle of the Triple "A".

Fig. 9

na Antartandes", in the Land of San Martin. The Route then continues over America, parallel to the Andes Mountains; but at the equatorial line, it turns sharply to the West and "links" the Earth, emerging from the East of Asia and crossing all of Europe. Always from East to West, the Route crosses the Atlantic Ocean as far as Mexico and Cuba, from where it turns northward again, covering almost the entire territory of the United States, part of Canada and Greenland.

Thus, following a tectonic scheme that is not always clearly discernible, the Kaly Yuga Route imposes a helical or "spring-like" movement around the Earth.

The lines that limit the Kaly Yuga Route are called in Esoteric Chorology, ISOCHRONIC CURVES, because they have been traced "at constant geochronic indices"<sup>4</sup>. Thus, seven large regions of different "geochronic intensity" are distinguished, each of them limited by isochronic curves (Fig. 10).

---

<sup>4</sup> *Isochronic, from the Greek roots: ISO = equal, and CRONOS = Time. It literally means "at constant time"; but in Chorology, isochronal curves allude to the constancy of the geochronal index.*

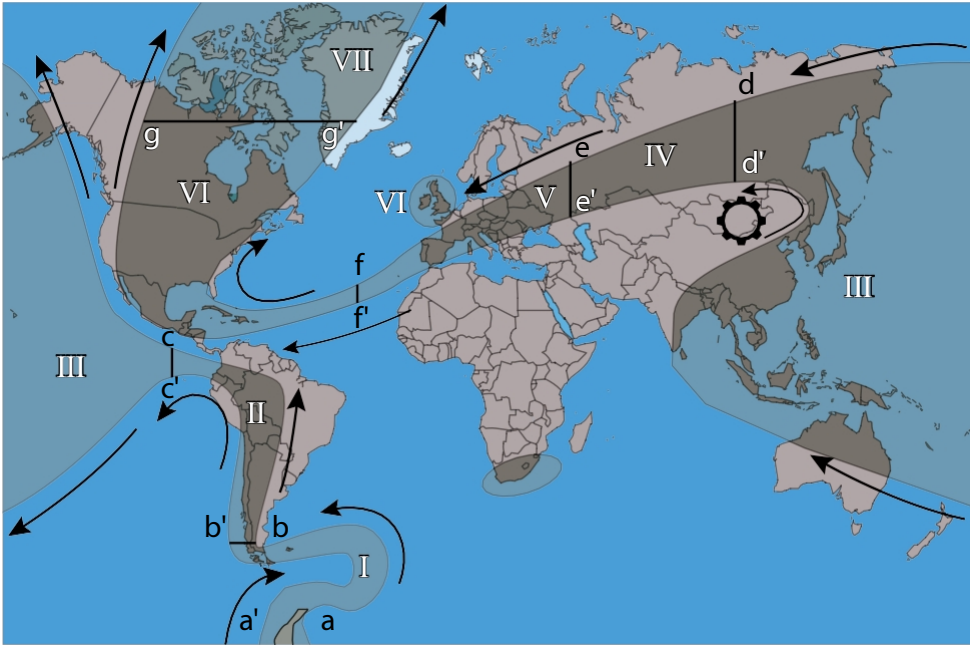

The Kaly Yuga engine and intensity zones on the route Fig.

10

Region I, "omega of the left hand", is an enclosure bounded by two isochronal curves and two straight lines; the first of these, a-a', is a segment of the Antarctic Arctic Circle; and the second, b-b', is a segment of the parallel that passes through the Chilean city of Punta Arenas. From there, Region II extends to the line c-c', which is part of the meridian "90° West". Region III covers a very large area ending at line d-d', which is determined by the meridian passing through Beijing. Then follows Region IV, always within the Route, i.e. bounded by two isochrones and two straight lines, which ends at line e-e', which is part of the meridian passing through Mount Elbruz in the Caucasus. Region V, distinctly European, ends at segment f-f', part of the meridian passing through the Island of Madeira. From there, Region VI extends to segment g-g', part of the Arctic Circle; and, beyond that, lies the end of the Route: Region VII, "of maximum darkness".

There are also two geo-chronological zones outside the Route: one, covering South Africa, has the dimensions of a Region V; and the other, including England and Ireland, is a clear sample of Region VI, "closer" to the end of the Kaly Yuga than the nearby European Region V, i.e., where the darkness of the Kaly Yuga is one degree closer to the end of the Kaly Yuga, i.e., where the darkness of the Kaly Yuga is one degree closer to the end of the Kaly Yuga.

than in Europe.

It has also been indicated, in Fig. 10, with a large cogwheel whose axial center or axis is located in Mongolia, the "CENTER OF LESSER INTENSITY OF THE KALY YUGA" (OF THE EARTH), which we mentioned in item 1 of this introduction. Strictly speaking, this "center" is the vertex of a colossal vortex of energy that fulfills the function of giving "movement" to the Route, and that is why it is called "Motor of the Kaly Yuga", although it would be more appropriate to say "eyebrow of Sanat Kumara". Analogously to the eye of the hurricane, in the "center of lesser intensity" reigns an absolute calm that allows its inhabitants to reach the highest transcendence; that is why the Hyperborean Siddhas have counted, and always count, on those inhabitants, the Mongols, when their plans of Psychosocial Strategy require the mobilization of peoples of Hyperborean lineage in different Regions of the Route.

The elementary notions of Esoteric Chorology that we have previously developed will allow us to interpret, from the point of view of the Hyperborean Wisdom, numerous facts that, until now, except in the closed circles of the Thulegesellschaft, had been the object of synarchic cultural disinformation. We will give some examples of such an interpretation in the following comments:

**A.**

In synarchic occultism, a crazy and tenacious association is usually established between the Swastika, the polar or circular movement of the constellation of the Big Dipper, the number seven, the regions of the Turan or Mongolia and the "Hyperboreans". As a product of this, statements such as this one are "proved" or substantiated: "Mongolia is a center of diffusion of the Swastika; from there it spread to the whole world"; or this one: "the Swastika symbolizes the helix movement of the Ursa around the polar star". We will not waste time in refuting these and many other similar statements; in the light of the Hyperborean Wisdom and with the help of Esoteric Chorology, we will go directly to the origin of the confusion.

First of all, it must be repeated that the Swastika is an exoteric expression of the Sign of the Origin; and as such, it DOES NOT REGISTER A "CENTER OF DIFFUSION"; since every virya, anywhere in the world, sooner or later encounters this Sign when, in his Strategy of Return to the Origin, he enters into a charismatic relationship with the Gral. This is what has happened in historical times with peoples who, inhabiting megalithic zones, have ended up "discovering" for themselves, and adopting as their coat of arms, the very ancient sign of the



Swastika.

We shall now make a very important distinction about the origin of the "Hyperboreans", for there are at least three traditions worthy of consideration, but contradictory among themselves. We will mention them in order of antiquity and clarify to what kind of "hyperboreans" each one refers; but first we will say a few words about the term "hyperborean".

The usual meaning is that "Hyperborea", as it appears in Homer and other Greek poets, alludes to a country "beyond" (hyper) where the North Wind (Boreas) blows. But this is a late etymology, from the time when the nascent Greek racialism associated to each "force of nature" a God or Myth; so it happened with the Sun (Helios), the Moon (Selene), Venus, Saturn, the Sea (Poseidon), etc., and naturally, the Winds: the North Wind, Boreas; the South Wind, Noto; the East Wind, Euro; and the West Wind, Zephyr. Before these mythological reductions, "Boreas" meant "breath of the North", as in BORÉIOS (boreioz) with a double meaning of "wind" and "spirit", as it happens with PNEUMA (πνευμα) which has the following meanings: breath, WIND, breath, breath, life, soul, SPIRIT, angel, demon, di- vino breath, HOLY SPIRIT, etc. "Hyperborean" can then be translated, in an archaic sense, as "Spirit proceeding BEYOND the North"; and Hyperborean to be "the country (or the origin, provenance) of the Spirits of BEYOND the North". This definition, evidently inspired by the memory of blood, is quite in accordance with the teachings of the Hyperborean Wisdom, which states that the captive Spirits come from Hyperborea, an extraterrestrial, but also "extra- universal" and perhaps antimaterial "racial center". From there the Hyperborean Spirits, whose nature is hostile to the material order of the Demiurge, entered the Universe through a cosmic door known in the Mysteries as the "Gate of Venus". Why did they do so? It is part of the Mystery; but some have supposed that they came from losing a cosmic war in other unimaginable universes; however, the most sensible thing is to think that THE WARLIKE CONDUCT OF THE HYPERBOREAN SPIRITS IS THE PRODUCT OF

THEIR ESSENTIAL HOSTILITY TOWARDS THE MATERIAL ORDER. The fact is that, although the Hyperboreans have always claimed Hyperborea as their Homeland of the Spirit and have preserved an indelible memory for it, once they have fallen in incarnation, by a Mystery of Love, this memory has become sufficiently blurred that it is only appropriate to speak of a "nostalgia for another world". In the memory contained in the blood Minne there must not be a clear memory of Hyperborea, because this can only be "seen" by the pure Spirit or Vril; what there is in the blood is the REMEMBRANCE OF ORIGIN, that is to say, of the place of origin of the Spirit; and this memory responds to a magic word, which should not be manipulated too much in order not to increase its semantic degradation, which is written: THULE.

THULE IS THE NAME OF THE ORIGIN AND, THEREFORE, ITS GRAPHIC SYMBOL IS THE "SIGN OF THE ORIGIN", FROM WHICH THE RUNE SWASTIKA IS DERIVED BY MUTILATION AND DEFORMATION.

With these clarifications we can consider the three traditional origins of the "Hyperboreans".

**First** - The oldest tradition, Germanic-Nordic, is that which places Hyperborea in the far north, in an area populated today by Arctic ice. This tradition has no other foundation than the blood memory of Thule and its associations to various "motifs" taken from the Akashic records, from Valhalla Island to Frisian Atlandia.

However, when the memory is very clear and refers to an island inhabited by giants who possessed a terrible spiritual power called "Vril" and beautiful women magicians capable of giving a love that immortalized the beloved, what we are talking about is the Hyperborean Siddhas and the island of Valhalla, which was once really in the North, millions of years ago.

**Second** - Another tradition, much more recent, about ten thousand years before Jesus Christ, makes the "Hyperboreans" come from the west, that is, from the western west. This is a Greco-Mediterranean Atlantean tradition that is not only the heritage of the Greeks -they are the ones who best expressed it in historical times- but of all the remnant peoples or vassals of the sunken Atlantis: Ligurians, Basques, Berbers, Egyptians, Cretans, etc. Here allusion is made specifically to the Cro-Magnon migration that advanced, as we shall see later, following the reverse of the Kaly Yuga Route, that is: from the Atlantic Ocean, through Europe and Asia, towards China and, by sea, to South America. Of course, NOT ALL the chroma- nions reached the end of the Route. The route took thousands of years, as the stone masters were readapting the psychoregions; and various groups, after remaining for centuries in one place, eventually formed many of the "historical" white peoples. But the migration, its central nucleus, did not stop until it reached the "omega of the left hand"; the evidence of its passage are the traces of interbreeding with "giants of the white race" that can be observed all along the Reverse Route, from Eastern Europe, Russia, China, Japan, Pacific islands; and South America, from Colombia to Tierra del Fuego.

This second Tradition, then, does not allude to the Hyperborean Siddhas, but rather to the Cro-Magnon who were, in a spiritual sense, authentic "hyperboreans"<sup>1</sup>.

**Third** - The last tradition consists in affirming that the Hyperboreans, primitively, came from the East, without specifying a particular place. Such activity varies with the different ethnic groups considered, for while some Germanic peoples claimed to come from the Caucasus and others from the Ukrainian plains or the Ural Mountains, the white tradition is often linked to the yellow tradition by moving eastward, clearly linking it with the shamans of Siberia and Mongolia. On the other hand, in India, the Indo-Aryans coming from Iran, that is to say, from the West, always admitted a "Nordic" origin; but here it is a question of the North of India, that is to say the Himalayas and, beyond, Mongolia. This Tradition also has its basis of truth, like the other two; but in this case the error lies in identifying the whole ethnic community with certain "Gods" or Legendary Heroes who in truth came from East Asia, or more specifically from Mongolia. Of course, we are not referring to the Masters of Wisdom of Chang Shambhala, so dear to Western theosophy, but to some Hyperborean Siddhas who, taking advantage of the "center of lesser intensity of the Kaly Yuga", burst from there into the history of the peoples to carry out a racial strategy. From there came Odin-Wotan and to there returned, every nineteen years, the hyperborean Apollo, who left a cultural trace of that transit to the East in the symbols of the Bear, the seven, the pole, etc., which were held by many of the peoples who were "on his way".

It is true, then, that there were "Hyperboreans" coming from the Far East, as the third tradition mentioned above affirms, but they were Hyperborean Siddhas (who were later incorporated into mythologies as Gods, Angels or Heroes) and not migratory peoples.

## **B.**

The Cro-Magnon, masters of lithic art, begin their strategic movement FROM THE ATLANTIC, following the reverse direction of the Kaly Yuga Route. They begin in Region V (Fig. 10), where they apply almost all of their megalithic science, and then slowly move towards Regions IV, III and II. In each Region three things happen: one group DISAPPEARS FROM HISTORY; another group disappears from history.

---

<sup>1</sup> *However, from the point of view of the current hyperborean lineages, it is that Cro-Magnon migration that explains the origin of the white race and its geographical distribution.*

The first group settles in the psychoregion, especially to practice agriculture and animal husbandry; and a third group, the bulk of the race, moves in the manner indicated toward the southern regions. While this migration takes place, that is to say, during thousands of years, the Hyperborean Siddhas IN CHARGE OF CONDUCTING THE CRO- MAGNON STRATEGY settle in the "center of lesser intensity", where they open a door to the Valhalla Island, called by them Agartha. Such a doorway, a NADDI topological tunnel between dimensions of space, ORIENTED INWARD FROM LATTERA, is the origin of the belief that Agartha, the land of the Siddhas, is a "subterranean world". It is worth noting here a fact that will later become important, when we reveal the "Incredible Secret of Heinrich Himmler": THE HYPERBORNE SIDDHAS WHO CONDUCTED THE CHROMAGNON STRATEGY WERE OF YELLOW RACE. This

This particularity was due to the fact that these Siddhas were, hundreds of thousands of years ago, the ones who developed and taught the Acoustic Kabbalah to the Cro-Magnons in the Second Atlantis.

### C.

Connected with this theme we must consider the General Strategy of the Führer, for, it can be assured, whoever ignores the existence of the Kaly Yuga Route will never be able to understand the offensive towards the East that Germany undertook during the Second World War. Political explanations have been tried - the purpose of annihilating the Russian communist regime - or geopolitical ones - the need to conquer "vital space" or lebesranm in the East - but the real strategic objective was known only to very few people in the Third Reich: the Führer, Rosenberg, Rudolf Hess, Himmler, the SS initiates and a few others; and this objective was as follows: to march with a Luciferian army, under the banner of the Swastika, along the Kaly Yuga Route IN REVERSE - it is said "down the Kaly Yuga" - to South America. However, the success of such an esoteric objective could only be achieved by carrying out a reckless "commando" operation consisting of occupying the center of lesser intensity, in Mongolia, and "operating the gate of Agar-tha". We will return to this matter to explain why this operation failed despite several attempts to accomplish it, with greater or lesser desperation.

### D.

"Within the Path of the Kaly Yuga are distributed the principal chakras of the Earth". This statement of the Hyperborean Wisdom would not require comment except for the possibility of misleading the statement we made elsewhere in the work, that "Israel fulfills the function of the heart chakra or Anahata chakra of the Earth". Indeed, looking at figure 10, it is clear that "Israel serves as the heart chakra or Anahata chakra of the Earth".

It seems to contradict the above statement that the State of Israel is outside the Route. But there will be no possibility of error if we clarify that the Israel chakra is built by the "chosen race" and not by the State of Israel. On the contrary, the concentration of members of the Hebrew race in Palestine IS AN ACT OPPOSITE TO THE PLANS OF THE SYNARCHY, a matter that the Führer knew perfectly well, and that is why he tried to favor the emigration and settlement in "Eretz Israel" of the European Jews. Several negotiations between Germany and England to realize this migration<sup>1</sup>, were frustrated by the intrigues of English Freemasonry, a synarchic organization that, contrary to common belief, was opposed to the eradication of European Jews. The reason is eminently esoteric: the function that, in the planetary anatomy, the Hebrews fulfill consists in producing a COLLECTIVE contact between the "emotional body" of the Earth and the consciousness of the Demiurge; AND THIS FUNCTION CAN ONLY BE EFFECTIVE IF THE DIAPORA, THAT IS, THE WORLDWIDE "DISPERSION" OF THE JEWS IS MAINTAINED. At

Figure 11 shows, by means of shaded areas, a current picture of the world distribution of the Hebrew race, which eloquently demonstrates that THE MAIN OBJECTIVE OF THE JEWISH STRATEGY IS NOT ZIONIST BUT SYNARCHIC.

#### **E.**

Let us now recall what we said in paragraph 2 of this Introduction: "The mission of the Mongols in History is to push the hyperborean lineages of the white race towards the Kaly Yuga". In the light of what has been seen so far, it should be clear by now that it is indeed possible to "advance towards the Kaly Yuga" by traveling through the different Regions of the Route. And that is what has happened - an advance toward the Kaly Yuga - to many peoples of hyperborean lineage whenever a Turanian invasion forced them to leave the lands of the East. Although such a "push" towards the West has been repeated in countless opportunities since the most remote antiquity, let us remember only, as an example, some of the events carried out by Turanian races in the present Christian era, thus proving that the displacement always follows the Route of the Kaly Yuga: in the 4th century, the irruption of the Huns in Europe produces the invasion of the Germans to the Roman Empire; in the 9th century, the Magyars, coming from the Ural Mountains, invade Transylvania "pushing" towards the West the Germanic and Slavic tribes that inhabited that region; in the 13th century, a Mongol Empire under the command of Genghis Khan attacks Armenia, Russia, Poland, Hungary, Silesia, etc. From the 14th century onwards, a great Turkish expansion began to press on the West, ending with the Eastern Roman Empire in the 15th century and, in the 17th century, it came to occupy

---

1 *Before 1939.*

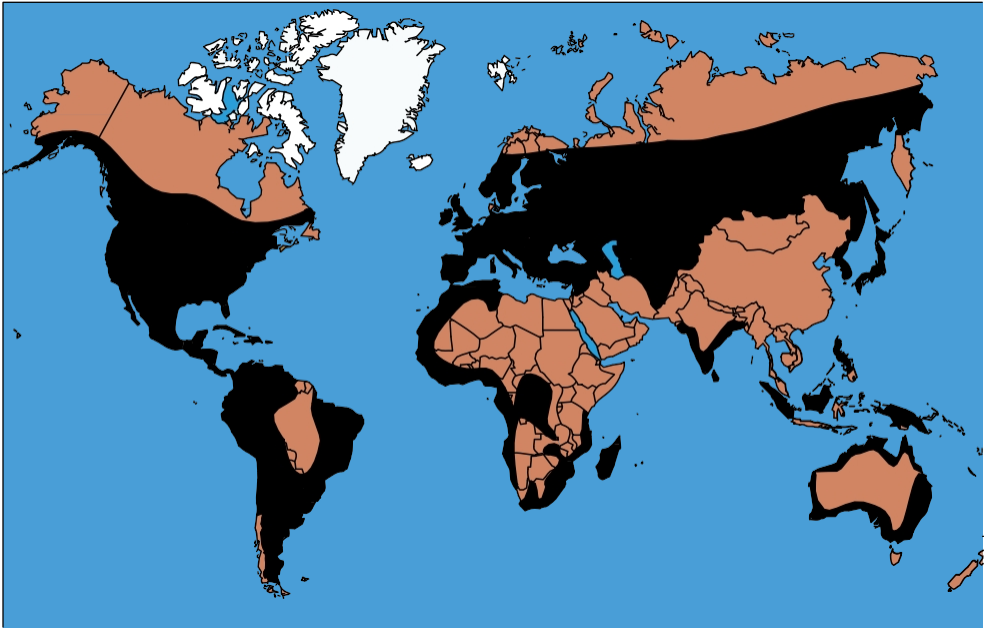

Hebrew Race: Main areas of distribution (1980) Fig.

11

Vienna; etc.,  
etc., etc.

If History is eloquent with regard to the statement in Item 2, it is not clear - and we will try to clarify it - what the objective of such invasions of the Turanian races is, since they have always been provoked by the Hyperborean SIDDHAS. The strategic objective - which was naturally also contemplated in the Führer's General Strategy - was the following: to put an end to the Kaly Yuga. To this end, the Hyperborean lineages of the white race must enter the Route of the Kaly Yuga until they reach the maximum darkness and then, from there, they will have to travel the Route in the opposite direction, towards the East, under the command of a Great Chief who will wage Total War against the Infernal Powers and achieve for the race, in the heat of combat, the definitive mutation, the magical change that transforms the animal-man into a semi-divine hero and the hero into an immortal Siddha.

This objective has been proposed by the Hyperborean Siddhas for thousands of years; but only recently, thanks to the Esoteric Chorology of the SS and its discovery of a Route of the Kaly Yuga, it has been possible to understand the occult reasons behind it. And that is why, based on the Hyperborean Wisdom, which is the mother of the sciences of the SS, we can affirm that the General





Führer contemplates ONE LAST ATTACK ON THE WEST BY THE TURANIAN RACES, BEFORE THE END OF THE KALY YUGA IS REACHED.

That time it will be the Siddha Anael who, at the head of enormous Mongol armies, flying again a banner with a polar sign, will advance irresistibly along the Route of the Kaly Yuga. But the little Judaized men, sunk in the darkness of sanguine confusion, WILL NOT SEE THE SIGN NOR WILL THEY UNDERSTAND THAT THE END HAS COME. They will believe until the last moment that they are witnessing the advent of the Synarchy and will rejoice in it foolishly. They will only react when, unbelievably, FROM BERLIN THEY SEE THE ARMY OF IMMORAL MEN ARISING.

SUCH AS WEAR THE UNIFORM OF THE ETERNAL SS. But then it will be too late, for they will spread out in all directions, possessed of a berserkir fury? AND WILL ONLY RESPECT THE SIGN OF THE PURE BLOOD.

#### F.

A Strategy of the Siddhas consists, then, in "pushing" the heroic lineages of the white race "towards the Kaly Yuga" by employing for this purpose the Turanian races, coming from the center of lesser intensity, as a "tactical mass". To prevent such an objective, the Synarchy has at all times sought to "move the horizon" away from the Kaly Yuga by deepening the exploration of the Regions of the Path. And with such a motive one of its infernal agents, a Jew known as Christopher Columbus, prolongs in the 15th century the European transit to Region VI of the Route (see Fig. 10).

This is the secret objective of the "discovery" of America that we mentioned when we presented Dr. John Dee's Project Thule, but which was impossible to explain at the time without resorting to the elements of Esoteric Chorology, such as the geochronic concept of the Kaly Yuga or the Chorography of figure 10.

The Synarchy has thus tried to ensure that the Strategy of the Siddhas - "to march westward and then return, with blood and fire, to the East" - is hindered by the water barrier that the Atlantic Ocean places between Regions V and VI.

In this sense, Columbus' "discovery" has been successful (but this is relative since England and Ireland, for reasons that we will not discuss here, respond to the chorological characteristics of an authentic Region VI, a quality that has allowed leaders such as Napoleon or the Führer to plan strategies that exclude America as a war objective).

**G.**

Figure 9 shows a tricontinental triangle, whose vertices are located in Beijing (Asia), Algiers (Africa) and Buenos Aires (America), and which, taking into account the initial letters of the continents, is called "of the three A's".

We have already spoken in the Second Dissertation of the Anael Order of South America, founded by the Hyperborean Siddhas after the catastrophe of the Second World War. According to the directives given to the Order in 1946, the Siddhas would promote in the world three foci of conflict OUTSIDE THE CONTROL OF THE SYNARCHY. These foci would not be located on the Kaly Yuga Route, where the travesty of an East-West "confrontation" would be executed to further the World Government plans of the Synarchy, but outside of it; and therefore the peoples involved in the conflict would be called "Third World" or "Third Position Holders". The three focal points, which in the Anael Order were called "apexes of liberation", became effective after a few years: that of Peking in 1949, after the revolution of Mao Tse Tung; that of Buenos Aires in 1946, after the electoral triumph of President Juan Domingo Perón; and that of Algiers in 1962, due to the independence of France.

In order to fulfill the proposed objectives, these "liberation apexes" should be organized on the basis of a national socialist or fascist principle, that is, with a policy that favors social justice "inwardly" and defends national interests "outwardly" from the borders. But the main thing would be that, starting from the liberation vertices, the conflict would spread to other centers of similar social composition. Such an effect was sought not to favor "the revolution", since such National Socialist liberation movements would operate outside the Socialist, Communist or Trotskyist Internationals, but to balkanize the areas of conflict with myriads of "independent" or "liberated" countries that would render the United Nations or other similar synarchical bodies inoperative with their contradictory votes.

The Chinese Revolution achieved this objective in Asia, but its most important role WAS TO AVOID A RUSSIAN INVASION INTO THE CENTER OF LESS INTENSITY, which would  
could be produced from the USSR itself or from Southeast Asia. Anael's Directive of 1946 said: "China and Africa constitute the body of a New World Order that will emerge from the chaos of the West, but without the haste of the Kaly Yuga"; and later: "Latin America will be the head of that new civilization, the Will of the Siddhas is committed to it".

China and Africa fulfilled their part of the Siddhas' plan in the 50's and 60's; what happened then with Latin America? Here the project was not new; for already in the 19th century Simón Bolívar had understood that without a South America united in pursuit of nationalist and patriotic objectives it would be impossible to resist the pressure of the great imperial powers; and without such a union any possibility of political, economic or cultural independence would be pure utopia. Anael's Directive for Latin America was based on similar considerations and that is why, as of 1951, powerful spiritual forces converged on three important personalities who were fundamental pieces of the Hyperborean Strategy: we refer to the Chilean president Carlos Ibáñez, the Brazilian president Getulio Vargas and the Argentinean president Juan Domingo Perón. These three presidents tried, between 1951 and 1954, to carry out a geopolitical plan called "ABC" (Argentina-Brazil-Chile), elaborated by the Anael Order of Brazil, which consisted simply in forming with the three countries an axis -the inclined "L"- that would allow resisting the pressure of the Anglo-American imperialism. The ABC axis contemplated the political, economic and social integration of the three countries, which would thus consolidate the third "Vertex of Liberation".

Naturally, this plan failed after a sinister conspiracy drove Getulio Vargas to suicide in 1954 and another no less sinister counterrevolution overthrew President Juan Domingo Perón in 1955.

What are the current alternatives of the Siddha Strategy for the Third World? We could say, chorologically, that the Triangle of the three A's has "rotated" and that its vertices now point to other spiritual centers: the Pe- kin Vertex has moved to the "lower intensity center of the Kaly Yuga", in Mongolia; the Algiers Vertex is now in Tripoli, Libya; and the Buenos Aires Vertex, although it is not yet completely clear why, has moved to Santiago, Chile. From this last country will emerge, then, the head of a new hyperborean civilization of tricontinental scope, although, for this, it will first have to rise above the nations of Spanish America and summon them around a joint project of liberation.

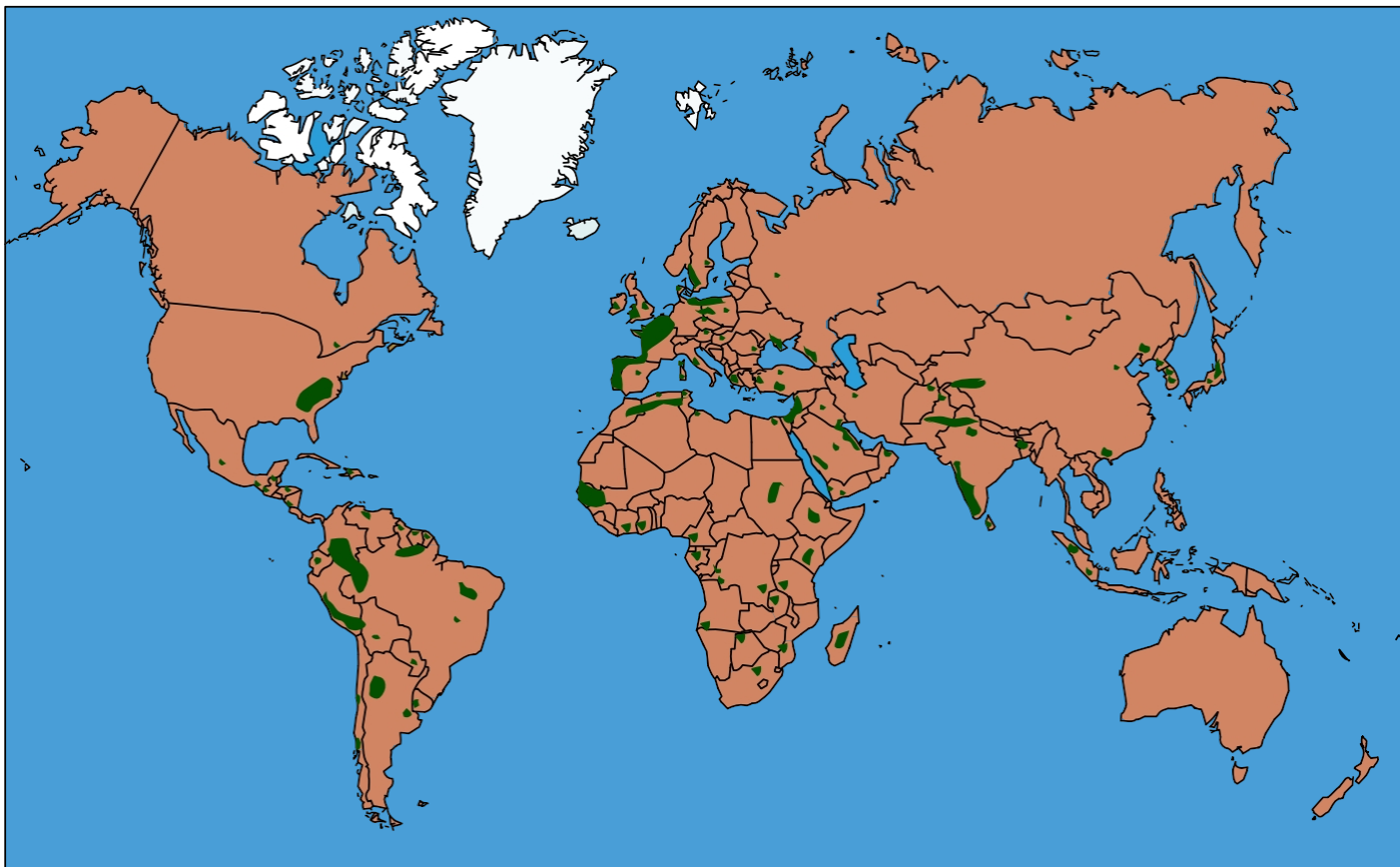

Worldwide distribution of megalithic constructions Fig. 

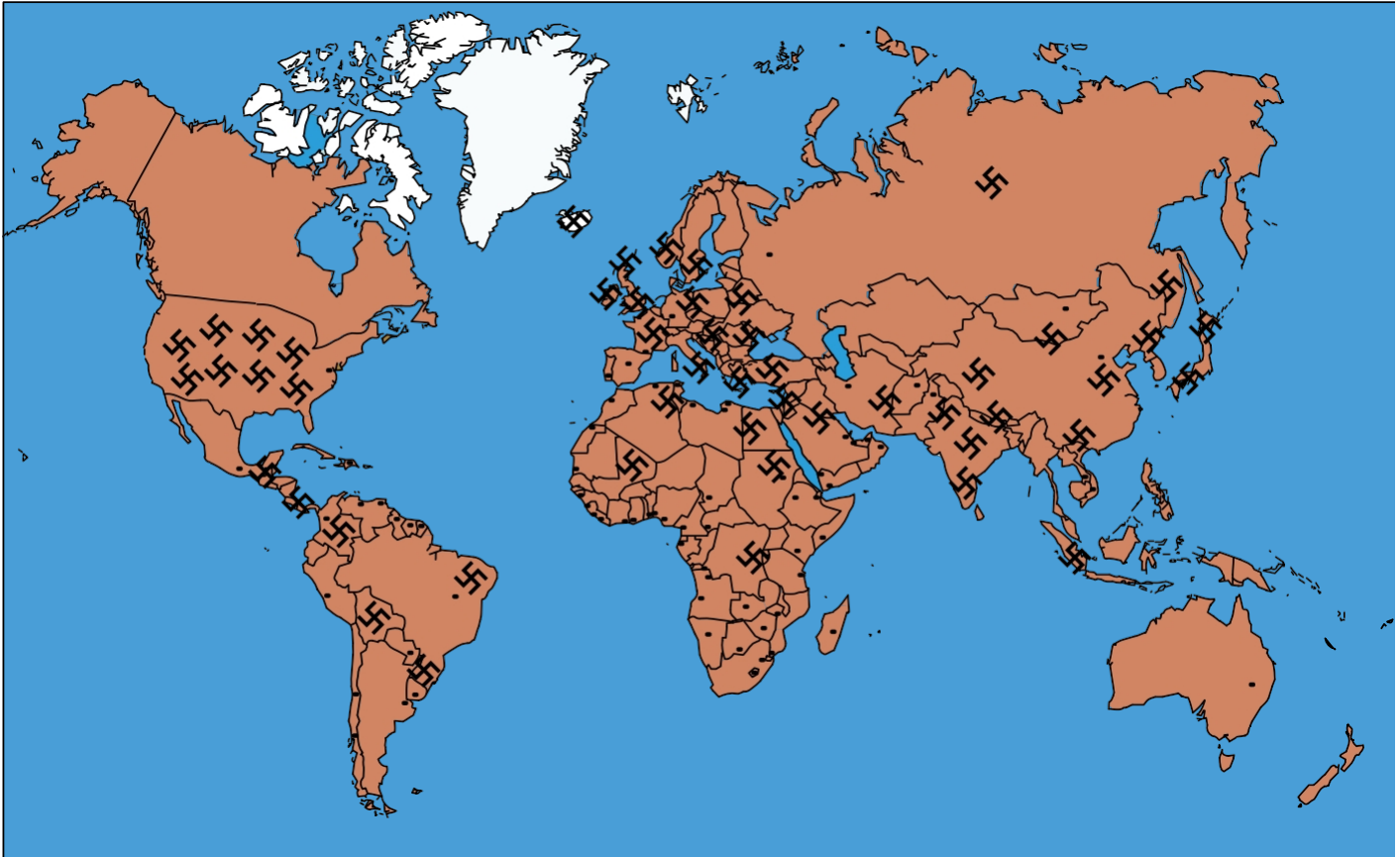

Worldwide Distribution of the Sign of Origin or "RUNE SWASTIKA"

Fig. 8

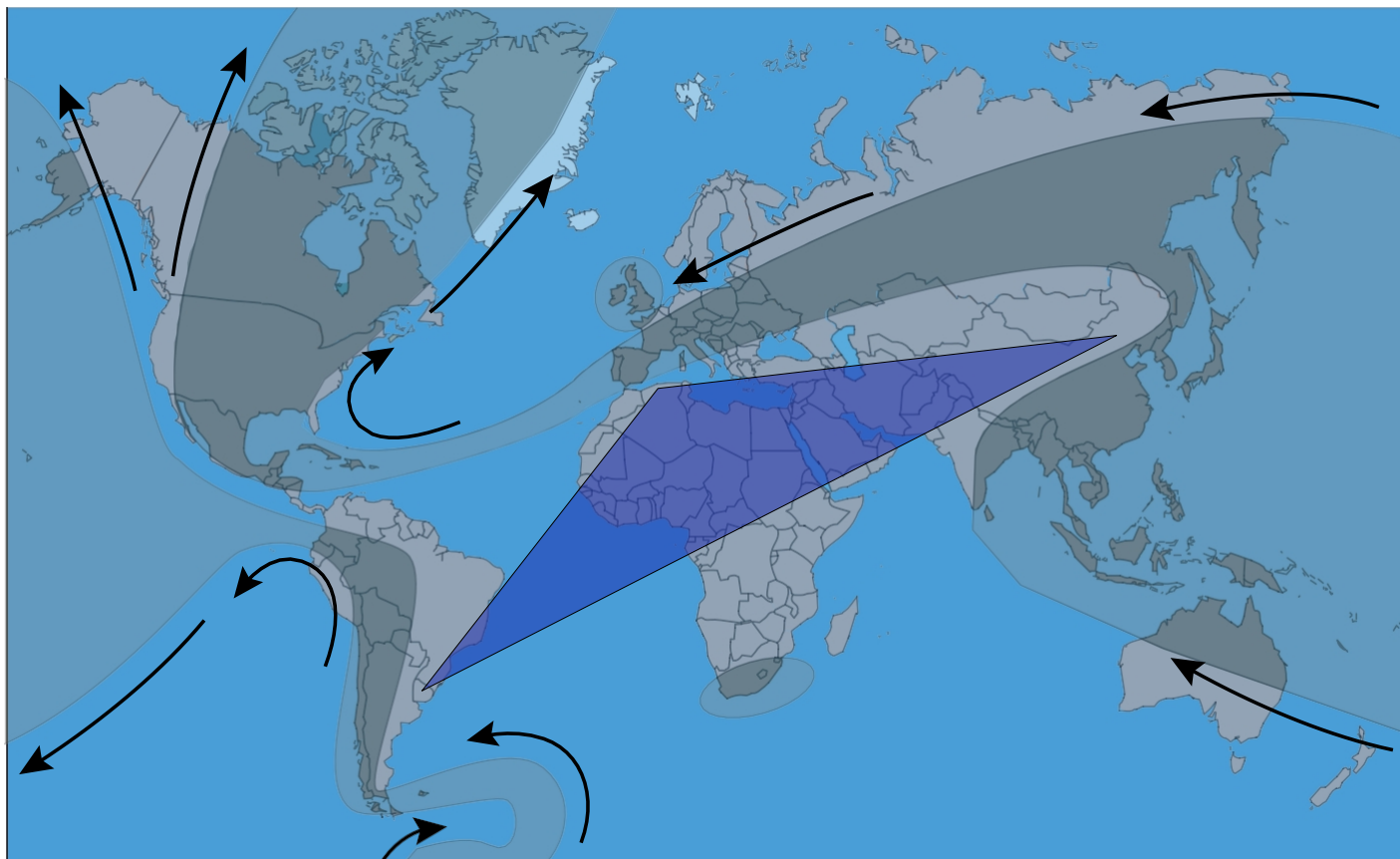

The Secret Route of the Kaly Yuga and the Triple "A"  
Triangle Fig. 9

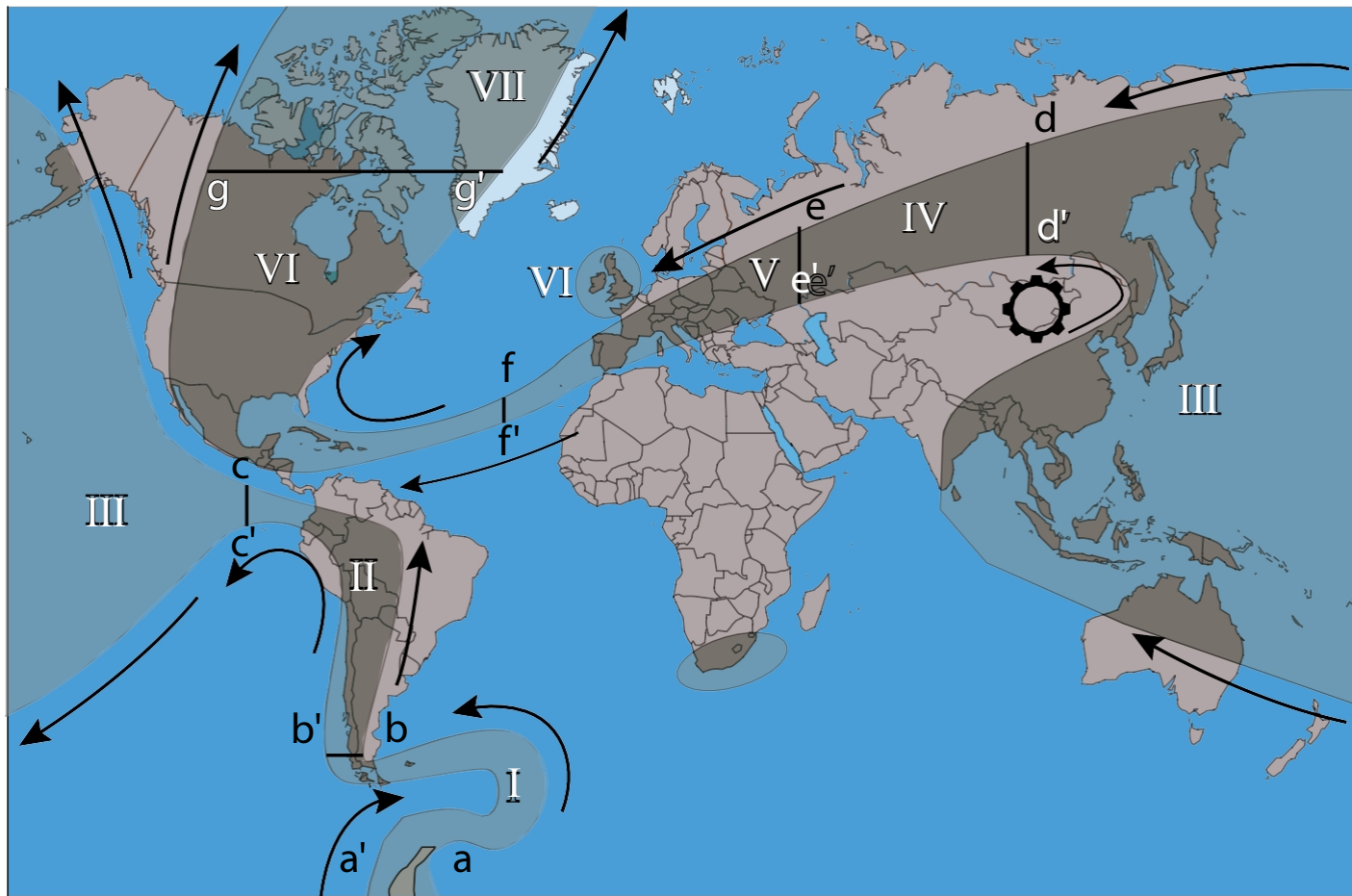

The Kaly Yuga engine and intensity zones on the route Fig.

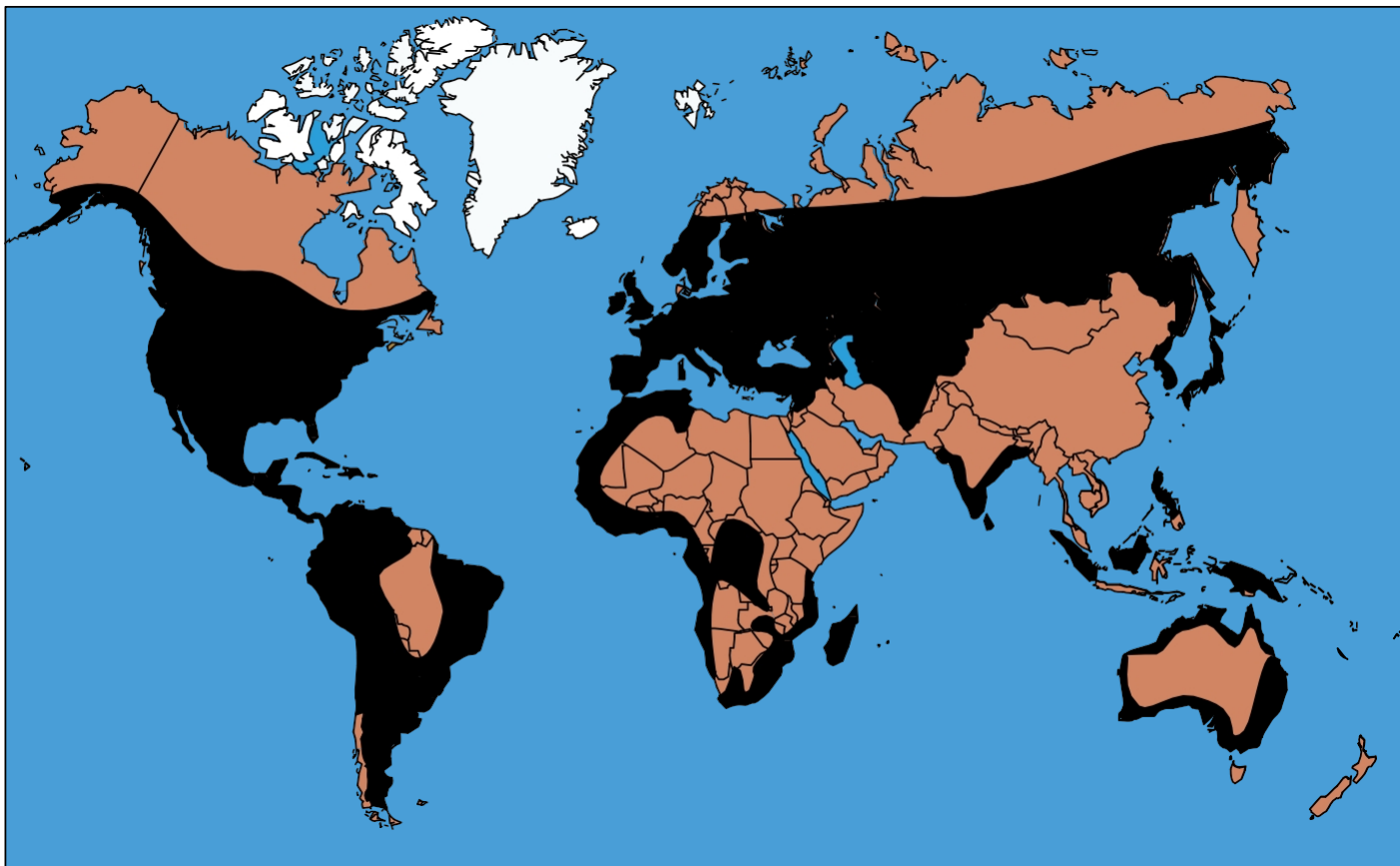

Hebrew Race: Main areas of distribution (1980) Fig. 11





This book was edited according to the Digital Version published in PDF format and can be downloaded from the following web page:

[www.hyperboreanpublishing.com](http://www.hyperboreanpublishing.com)