

FINAL BATTALION



55 CLUB

The Final Battalion

And the
Ultimate Hope of Mankind

By The 55 Club

CONTENTS

Introduction	9
The Exoteric or Facts and Science	15
The Early Developments	
Peenemünde	
Aryan Physics	
Die Glocke	
The Esoteric or Divine Science	47
The All German Society for Metaphysics	
The Deutsches Ahnenerbe	
The Lords of the Black Stone	
The Post War	81
Antarctica	
The War goes on	
The Secret Diary of Admiral Byrd	
The Right Perspective	
Northmen of Paraguay	
Paradise Lost	107
Hyperborea is Paradise	
Plato's Atlantis	
A Cataclysmic World	

The Giants of the Americas 127

- City of the Caesars
- Tiahuanacu
- Warriors of the Cloud
- Hy-Brasil
- Quetzalcoatl
- The Return of Quetzalcoatl
- Teotihaucan
- Votan
- City of the Sun
- The Lost Race
- Rivers of Blood
- The Ohio and Mississippi Valleys

Paradise Found 185

- Vril
- From whence We Came
- Many are Called Few are Chosen

Appendix

- Miguel Serrano and *The Golden Cord* 215

INTRODUCTION

There have been many books written about the subject of National Socialist Germany and their advanced technologies concerning flying discs or perhaps better known as U.F.O.'s. Today, there is also quite a fuss about the ancient giants, 'Nephilim', etc. What most of these books do not reveal is that they quite are related. Truth be known, both of these subject matters are irreversibly connected, for they are both part of a hidden history that those who are in power would prefer for you and I to know nothing about because the real story offers hope and choices. Therefore, the enemy makes every effort to conceal these overwhelming truths.

They want us to feel overwhelmed and helpless in their vice as they clamp down and destroy everything we have ever held dear and sacred. Thus, we accept conditions and compromise, again and again, so that we may just 'get along'. Conditions that in our heart of hearts we know are bringing us ever closer to complete ruin. All of this because 'we are alone', 'they have got it', 'there is no one else out there', etc. But there is someone else out there. There are those who have never stopped fighting for our interests and unbeknownst to most, we do have choices.

There is another path and although the enemy places one detour sign after another before that road, it is still open for those who have courage enough to stop listening to the very ones they know lie about everything. Alas, most people are just looking for a place to 'fit in' and as long as that is what is important to them – then that is what they shall get.

For example, the feel good flag wavers who do not really care if their war is just or how many hundreds of thousands of innocent children are murdered in the name of 'freedom and democracy'. These very same people usually consider abortion to be criminal. Their thinking only makes sense when we realize that they do not sincerely care about the truth. They really only want something which makes them feel good and at the same time does not jeopardize their cowardice-ness. This book was not written for those people.

Nor for the bleeding heart 'freedom fighter', who after witnessing the destruction of the community from their

'progressive liberalism' agenda, move far away to somewhere that is still safe and pleasant, only to begin their twisted, disastrous, feel good agenda again. These ever phony sociopaths will actually attack the very traditional values of the community that make it a pleasant place to live. Thus, beginning the sickness of reinstituting the 'progressive' cancer they have just fled. And just as the flag waver, they live this hypocrisy because it is allowed and encouraged. Again, they can convince themselves that they stand for something without ever jeopardizing their cowardice-ness. This book surely was not written for them.

It has been written for the one who follows his Star no matter where it may lead him. He who has the courage, faith and fortitude to struggle for that which is truly just - at all costs. The Noble Soul who is a friend to God.

In this work we reveal some information that, to the best of our knowledge, has not been expounded upon before. Timeless wisdom, in which, the seeker of truth is in need of at this present time. For as of now, there is an avalanche of disinformation being put forth by those who wish to keep us stumbling about in the dark. This is another tactic of the enemy. When they cannot keep us from knowing about a particular matter, they do the next best thing and muddle the waters so badly that, without your God compass, one may never find the truth. In fact, this is how they mislead most into still serving their interests.

It has been proven, time and again, that the Third Reich was on the cutting edge of 'spaceship' technology. And most today believe there are U.F.O.'s because so many have seen them. The number of eye-witness accounts are staggering. We are not saying that there are flying saucers and we're surely not claiming that, if they do exist, National Socialists are piloting the aircraft (our own governments have been testing these kind of crafts for many decades). What we are saying is that if there are U.F.O.'s - it was the National Socialists who reinvented or discovered that advanced science and this work will prove, at least, that much.

The only real question is from whence this bursting wave of technology came from? It is at this point that we cannot overlook the ancient myths or Holy writs. All the old books, from the Bible to the Mahabharata, speak of advanced beings, in a time passed, who were gigantic in stature. The ancient wonders of the

world (pyramids, stone circles, mounds, etc.) are not so mysterious once we accept that, once upon a time, divine beings openly interacted with humans. The myths are true!

This was done in two ways. First by divine plan and only later from demonic lust and ignorance. Jesus Christ is the perfect example of a birth by divine plan. The 'Rigsthula' of the Northman teaches us that God made the caste system in this very same manner. An accurate version of Zeus and Leda is another. Why even the book of Genesis tells us that their offspring were 'the men of renown'. The children of Gods and the daughters of men are the hero's that to this day can still inspire men to better action simply by learning their stories of chivalry and adventure. These semi-divine giants of old had more honor and nobility than the very best of men today. So, where did they go?

The disinformation agents of today will tell us that they were all destroyed in the flood because of their wickedness. Ha, what a lie! The wicked surely perish when the Father lets loose His Hammer, but not the Hero's of men. Those honorable sons of God would become what is known as the Hyperborean Hero Mythos. Thule was the center of Hyperborea and from there, the home of the Godmen, would come all that is noble and true upon this earth. By no means are we saying that there were not evil giants or dumb giants, which were those conceived without divine design. The dark giants were those conceived without foresight and were the monsters that many of the semi-divine heroes or demi-gods were conceived specifically for the purpose of vanquishing. What separated them was consciousness. It is the same difference between men and animals. Consciousness is the awareness of the divinity and the will to overcome the basest of instincts, or the ability to rise above. This divine gift of true reason is still with us, for the divinity of the giants is still here, it lives in us...

The Third Reich had special branches of investigation. It has been said that Hitler left no stone unturned. The Ahnenerbe of the S.S. was the division in search of the origins of the Aryan race. What they discovered in their world encompassing search and proved beyond a doubt was that the Indo-European is the direct descendent of the giants of old. A child can understand this. They are our Heroes! But it was the Ahnenerbe who

scientifically proved it. They proved that the reason we are more creative than others is because we are of God.

At this point, we should address some of the misperceptions of The Third Reich and ourselves, for that matter. The true Aryan soldier does not 'hate' other peoples, nor do we have a devious plan for their demise. We know that every race should have the right to rule their own destiny. This is a matter of common sense and common decency. For example, we have known short, round headed, dark haired Indo-Europeans with more Aryan characteristics than most. If you are one of those who falls into the trap of 'evil Nazi eugenic programs' know that they were in search of the gene, the D.N.A. etc, and never were they so shallow minded as the great liar has portrayed them. The SS were the return of Arthur's Knights and their integrity had no place for such pettiness. That being said, we make no apologies for the truth. An honest, spiritually orientated Indo-European is the Light which shineth in the darkness. Of course there are good people of other races, but it is usually a part of our blood and spirit within them that makes it so.

In their studies of Aryan origins the Ahnenerbe unleashed a tidal wave of information concerning advanced knowledge and the divine implosion. They were walking with the Gods. As a matter of fact, nearly everything the Germans discovered or implemented has been tried since then by the 'victors' to their utter, distorted failure because they may ever copy, but without the noble intention it shall not work nor last. Here is where the disinformation agents have their way with the people once again, the conspiracy theorists love to insinuate that 'the evil Nazi programs' are still in use today by the 'New World Order', as if somehow the only regime who ever actually fought and died battling the beast are part of the same conspiracy. Therefore, another detour from the road of truth and glory.

Let us try and comprehend the reality of the situation. The same wonders and divine science of the 'pre-recorded' ancient world, that are still today so beyond the understanding of our 'intellectuals', were received and achieved by Hitler's Germany. The wisdom of Hyperborea is like that of the Holy Graal. Both were taken long ago from the sight of men and since then, only the best and purest of heroes may attain them. Pure not as in

virginal, but purest as of their intentions. A pure heart, in which, God is the sole captain. In other words, if you are not willing to sacrifice everything for that which is true and just, then you shall not achieve the Holy Graal. The Graal is a spiritual matter and God loves a Hero or the just man.

* * *

This work was written in the simplest form that we could muster. It begins very dry and factual so that anyone may follow. As it progresses the material becomes deeper. A reader can jump off whenever they choose and perhaps, at a later date, continue. Our hope is only to give to the seeker of truth access to the unfiltered answers they are looking for.

In this work, we have purposely used and quoted a broad selection of sources. Our reasoning for this is that it should make it harder for the skeptics to discount the following information when much of it comes from those they would usually adhere to. Plus, with such a wide variety of topics, which are really one and the same story, a few sources would never be enough to outline tens of thousands of years of history.

We also contribute an ample supply of essential information from our faithful lineage. Those who have carried the torch of truth for millennia, ever passing the divine truths on to the next in a long line of tradition and wisdom, such as, the late great master Miguel Serrano. Don Serrano is a great source for this type of information, so much so, that we have included the introduction from his book *The Golden Cord* as an appendix.

In this work, the reader will surely find something that he disagrees with, but overall, one should find a sincere and honest effort to bring forth a wondrous history that has been hidden from man for entirely too long. A history of a pre-ancient cosmic war that seems as if its conclusion will have to play out right here on earth.

Less than a thousand years ago, the Church still taught that our world was at the center of the universe. Today, we know that this is not the case, and yet there is something true in that old line of thought. To be frank, it's not that the earth is the heart of

creation – it's that the heart of creation is here on earth. It's in the name, it's always in the name, but not until the First and the Last reveals Himself, that is, when the Last once again becomes First shall we see. EART-H.....H-EART. Alas, our dilemma it seems will have no solution until the great wrong is made right.

The spiritual war of the eternal return is cosmic in nature as well as within each and every one of us. A battle for our very heart and soul and also for the future of this world. The 'slaves of Atlantis' have every intention of destroying this earth, but it need not be so. There is an alternative for those who do not quit. The Creative Spirit, which is the Heroic Spirit, shall prevail, in truth He already has won. We are only unaware of this because we must still earn our place beyond the spiritual catastrophe.

Our hope is that in this little work that covers some 20,000 years we may shed a little light on the dark dilemma that most of us intuitively feel as long back as we can remember. Many succumb and just plain give up because it seems so much easier, but then there are those who do not. The great souls that please God are those who never give up even though they believe that there is no chance of winning. They continue to struggle only because they feel it the right thing to do and it is to them that the hope written of in this work is given.

So, the question is what are we going to do about it? Is one content with being a blind slave looking for the next distraction or an awakening Hero of God? Only our actions in time will tell.

Good Friday, March 29, 2013

- Joe Sevnsen

'The Exoteric or Facts and Science'

"If flying saucers exist, it is the V7 which I built in 1944, the engines of which the Russians seized at Breslau."

- German Engineer Dr. Richard Miethe

As previously mentioned, the highly advanced technology of the Third Reich has already been well documented by others. Let us begin with the first book ever published on the matter. The S.S. Major Rudolf Lusar was an Engineer at the German patent office during the war and is usually credited with being the first to publish material on the true origin of the UFO. In 1952, he released *The German Arms and Secret Weapons of the Second World War and Their Development*. In it he states:

"Flying saucers have been whirling round the world since 1947, suddenly turning up here and there, soaring in and darting off again at unprecedented speed with flames encircling the rim of the saucer's disc. They have been located by radar, pursued by fighters and yet nobody so far succeeded in establishing the existence of such a 'flying saucer' or managed to ram or shoot one down. . . Experts and collaborators in this work confirm that the first projects, called 'flying discs', were undertaken in 1941. The designs for these 'flying discs' were drawn up by the German experts Schriever, Habermohl, and Miethe, and the Italian Belluzzo. Habermohl and Schriever chose a wide-surface ring which rotated round a fixed, cupola-shaped cockpit. . . Within three minutes they climbed to an altitude of 12,400 m. and reached a speed of 2,000 km/hr in horizontal flight. It was intended ultimately to achieve speeds of 4,000 km./hr. . . Existing models were destroyed but the plant in Breslau where Miethe worked fell into the hands of the Russians who took all the material and experts to Siberia, where work on these 'flying saucers' is being successfully continued. Schriever escaped from Prague in time; Habermohl, however, is probably in the Soviet Union, as nothing is known of his fate. The former designer Miethe is in the United States and, as far as is known, is building 'flying saucers' for the United States and Canada at the A. V. Roe works."

The Early Developments

In this chapter we will straightforwardly present an entire documented history of advanced German flight. There will not be an honest soul who can deny that the Germans had created or recreated the 'U.F.O.' during the Second World War.

It was the aviation genius Hugo Junkers who first patented a wing flyer design over a century ago. There is where our story shall begin. Junkers was certainly in-genius. He had at first developed an affordable hot water device. His 'thermes' were soon everywhere producing hot water at any time. This made him flourish and soon Junker's factories were international.

His dream of worldwide air travel makes him the father of modern commercial flight. His visions knew only the limitations of the imagination and industrious work. After witnessing the horrors of the First World War he had become an avowed pacifist. Like many well meaning folk, Hugo forgot that there can be no peace without justice. This eventually led to the old man's forced retirement. Nevertheless, he was instrumental in paving the way to extraordinary, technological flight.

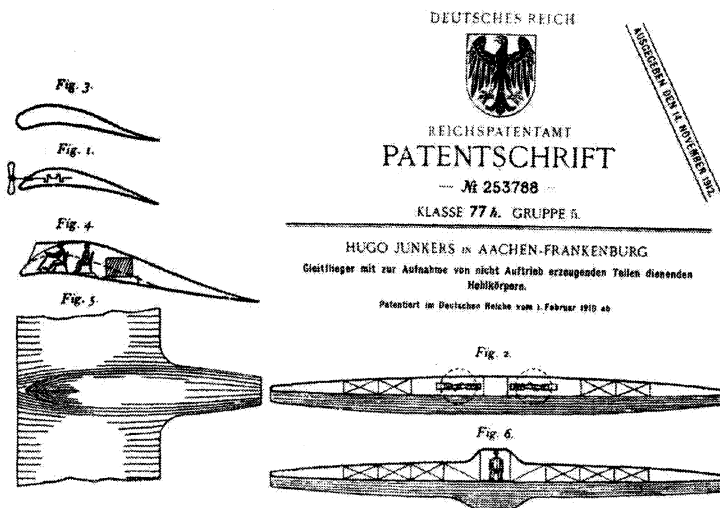

Hugo Junkers 1910 stealth winged flyer patent.

After the First War, the infamous Versailles Treaty forbade any form of powered flight in Germany (the first 'no fly zone'). German aviation enthusiasts turned to unpowered gliders. Wasserkuppe, a high plateau in the Rhon Mountains, became the center for glider sports. Practically anyone who later would become world renown in German aviation had been associated with Wasserkuppe. It is incredible how the Spirit perseveres.

In 1925, the prohibition against construction of powered airplanes was partially repealed. The change allowed Germany to organize the informal glider movement into the world's first gliding research organization, the Rhon-Rossitten Gesellschaft.

The appointed director of the Rhon-Rossitten Gesellschaft was Alexander Lippitsch. Lippitsch would be responsible for the first rocket-powered aircraft, the Ente. His research led him to a new design that was better suited for high-speed flight. He called this design Delta, based on the triangle shape of the Greek letter.

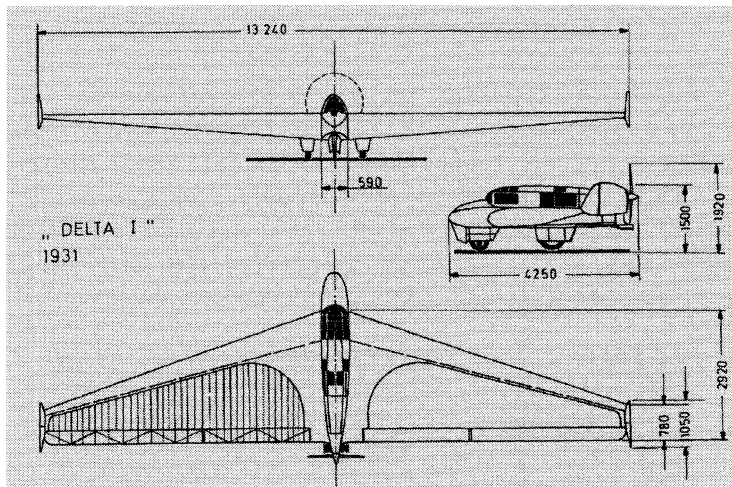

The 1931 Delta I design.

Lippitsch designed the rocket powered Messerschmitt Me 163 Komet, which was, the fastest 'documented' manned aircraft in existence during WW2. Perhaps his greatest accomplishments came when in 1943 he went to the Aeronautic Research Institute in Vienna where he began the Lippitsch P-13B. A ramjet design that reached 1200mph. It is claimed that the P-13B first broke

the sound barrier in early 1945. It had also been claimed that the 'Foo Fighters' came from this very same facility (Vesco). The 'Foo Fighters' are now well verifiable because of the release of classified documents. Therefore, making the P-13B broken sound barrier flight all the more credible.

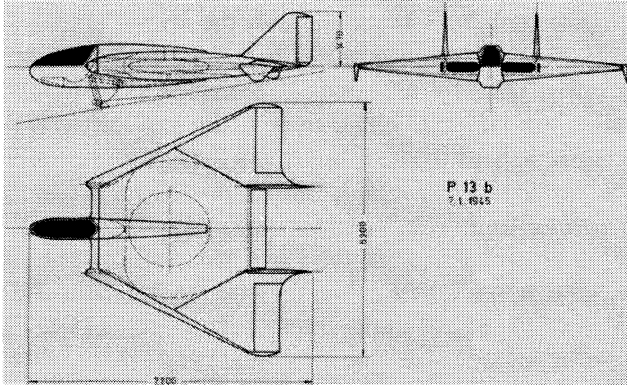

The Lippitsch P-13B.

Inspired by Lippitsch, the Horten brothers' Ho-229 could well be considered the actualization of previous stealth aircraft projects. Walter and Reimar Horten were still in their teens when they began designing flyers as a Hitler's Youth project. The brothers were enlisted in the Luftwaffe and received 500,000 Reichsmarks after successfully completing the early Ho-229 prototype (Reimar would work in Argentina after the war).

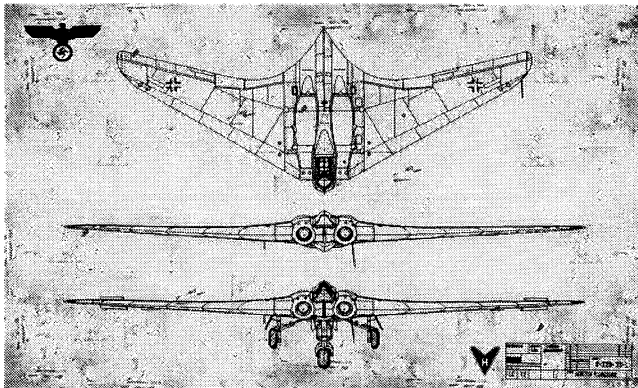

The Ho-229.

The Ho-229 design was sent to the Gothaer Waggonfabrik for production. Gothaer Waggonfabrik was a major manufacturer for the Luftwaffe during the war. Another Third Reich manufacturer on the cutting edge of exoteric, pioneering flight development was the Focke-Wulf Flugzeugbau. Founded by the aviation genius Heinrich Focke.

The list of their achievements is impressive. Focke designed and Hannah Reitsch flew the world's first helicopter. The Focke-Wulf Fw 61 was demonstrated in Berlin in 1938. Focke next patented the Focke Schnellflugzeug, which had a revolutionary turbo shaft system.

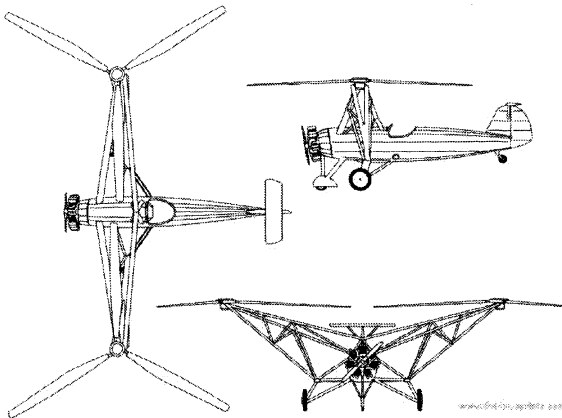

The Focke-Wulf Fw 61

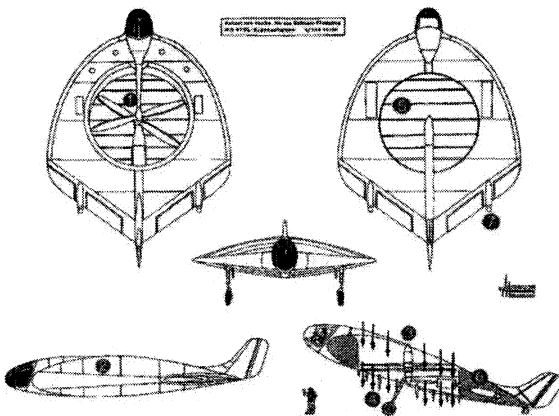

The Focke Schnellflugzeug in 1939

In collaboration with the Luftwaffe, the Peenemünde group developed liquid-fuel rocket engines for aircraft, constructed a power plant, a liquid oxygen plant, a wind-tunnel facility, a rocket production facility, a development works facility, the Luftwaffe airfield, etc. The site would eventually be home to over 2,000 scientists and 4,000 other personnel under the command of General Walter Dornberger. After the success of the V2, Dornberger was quoted speaking to his elated colleagues:

“For the first time we have invaded space with our rocket. Mark this well, we have used space as a bridge between two points on the earth; we have proven rocket propulsion practicable for space travel. This third day of October, 1942, is the first of a new era of transportation: that of space travel.”

Here is where our story really begins. Amongst the various projects now enters V2 engineer Heinrich Richard Miethe. Miethe and the Italian alternative turbine energy Professor Belluzzo seemed to have been paired up for a flying disc design. General Dornberger oversaw the flying disc program of Miethe and Belluzzo. After the war, both Miethe and Belluzzo claimed in separate interviews that they had been successful with the V7 disc craft project.

Simultaneously, along with the Miethe and Belluzzo disc, the team of Schriever and Habermohl had been assigned their own space disc project. Joseph Andreas Epp reports in *Die Realitaet der Flugscheiben* (The Reality of the Flying Discs) that an 'official' test flight occurred in February of 1945. There were several eye witnesses of flying discs in Czechoslovakia. These teams had several secret locations. By the end, most of the black projects were working at underground facilities in and around Czechoslovakia. Epp also tells us that Schriever and Habermohl first successfully flew their craft in 1944 at Prague.

Georg Klein, another famous German engineer and aircraft expert, claimed that one of Miethe's early designs was further tested at Peenemünde to become the world's first unmanned drone flyer and we see no reason to doubt him.

In the book, *Hitler's Flying Saucers*, Henry Stevens does a commendable job of documenting the existence of the secret disc

projects of the Third Reich. Stevens ascertains that a hidden hand was coordinating at least the both of these two teams. We agree. He identifies Peenemünde as the overlord. We disagree. The hidden master who was directing not only Miethe, Belluzzo, Schriever, Habermohl and the other projects that we will discuss in this book - was none other than Adolf Hitler.

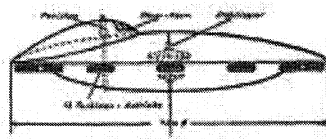
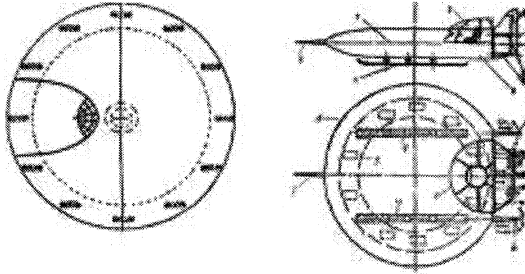

Miethe and Belluzzo 'V-7'

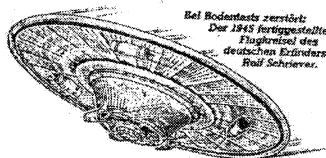
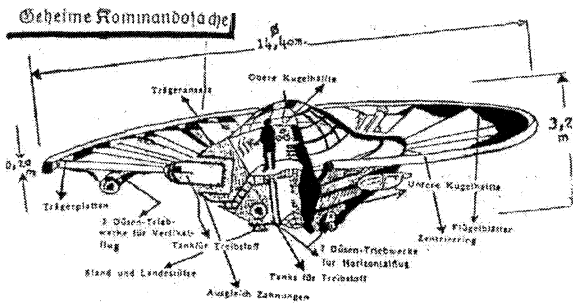

Bei Bodentests zerstört:
Der 1945 fertiggestellte
Flugkreisel des
deutschen Erfinders
Paul Schriever.

Schriever and Habermohl 'FlugKreisel'

What makes these discs remarkable and yet so marvelously simple is the air intake system. This spinning suction would not only reduce resistance to virtually zero but also create energy. First, this produces the effect of speed without any resistance. "As a bar of soap would shoot out of your wet hands because you would not be able to hold it, so would a vehicle operating on this principle" or as Stevens says:

"The genius of the German designers was to combine the ideas of suction and circular wings into a single aircraft. Housing complete aircraft within its wing would eliminate the fuselage and so eliminate an unnecessary, drag-causing structure."

Second, This electro-magnetic, anti-gravity system would create it's own gravity separate from the rest of the cosmos. Sudden accelerations or changes in direction would not affect occupants within the vehicle because they are within their own gravity field. They are separate from the surrounding gravity of our world as we know it. An explanation for this scenario was given by the oft-time mysterious German Physicist Hermann Oberth. Oberth, mentor of Wernher von Braun, always believed there were spacecrafts - as he well should. Unlike the flamboyant von Braun, there are years that Dr. Oberth's activities while working for the National Socialists are unknown. He was once quoted as saying:

"They are flying by means of artificial fields of gravity... They produce high-tension electric charges in order to push the air out of their paths, so it does not start glowing, and strong magnetic fields to influence the ionized air at higher altitudes. First, this would explain their luminosity... Secondly, it would explain the noiselessness of UFO flight... Finally, this assumption also explains the strong electrical and magnetic effects sometimes, though not always, observed in the vicinity of UFOs."

Miguel Serrano presents a military document in his book, *Adolf Hitler, the Ultimate Avatar*, that he discovered circulating within the Federal German Authority. It is that of a Third Reich

flying disc. It appears to be of common knowledge amongst 'authorities' that the National Socialists had created such crafts.

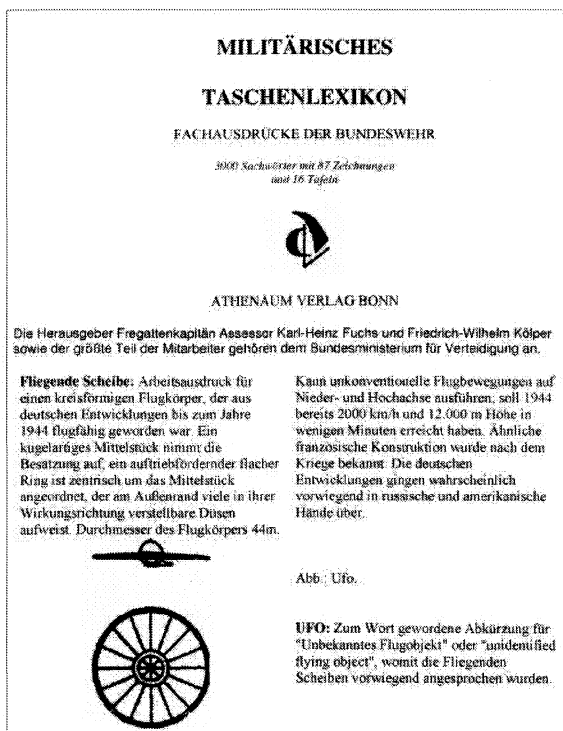

“The word UFO, referring to Unknown Flying Objects (Unberkante Fliegenden Objette), appeared in the ‘Militarisches Taschenlexikon,’ Fachauskrucke der Bundeswehr, of K.H. Fuchs and F.W. Kolper, published by ‘Athenaum Verlag, Bonn,’ in Bad Godesberg in 1958, in the section ‘Flieger,’ dedicated to the Air Force and pertaining to the lexicon of the Armed Forces of Federal Germany. And this shows the Third Reich, in 1944, had a list of ‘flying objects,’ in disk form, reproduced in profile and from above. The ‘disk’ would fly more than 2,000 kilometres per hour. The publication in my possession does not say if this vehicle was given to the Russians or North Americans, after the war, since it was not found. That was in 1944.”

- Miguel Serrano

Aryan Physics

“Quantum theory will not look ridiculous to people who have read Vedanta.”
- Werner Karl Heisenberg

The question that one should be asking themselves by now is what is the origin of this quantum leap in German science? One obvious answer is ‘Deutsche Physik,’ better known as ‘Aryan Physics’. The National Socialists threw out Einstein’s dead end ‘Jewish physics’ of relativity and began to experiment within the laws of creativity and nature, for it was so much more than just ‘science’, it was a world view which encompassed tens of thousands of years of history. Before delving into the ‘Aryan psyche’ of physics, we should take a look at Horbiger’s cosmic theory, better known today as the ‘World Ice Theory’.

The Austrian engineer, Hanns Horbiger, had a passion for astronomy and it is said that while gazing upon the night skies he had an epiphany. By 1917, in collaboration with another amateur astronomer, Philipp Fauth, he released the book, *Glazial-Kosmogonie*, (Glacial Cosmogony) in which, he gave evidences in support of the ancient ‘Aryan myths’.

In it he proposed that the universe is made up of fire and ice and that all life (water) is made up of such. He gave an account of ice worlds colliding with fire worlds throughout time and much more. But here is what was important – our world is a product of these cataclysmic collisions. And along this train of thought was presented a forgotten history of our world, a forgotten history that was coined ‘Weltaislehre’.

According to Horbiger, the beginning of this age was marked by ‘giants’ who had survived the last collision. The ‘giants’, safe from the floods, raised great civilizations in the Andes, Himalayas and so on. Eventually the ancient ones of renowned ‘faded away’ and man has declined into the dullness of a Judeo-Christian existence and has forgotten his glorious past and legacy, but this is only temporary. Once again man will awaken to the realization of his place in a living universe and will transform his existence. The semi-divine will again arise in our midst, for an ‘uprush of fire’ is imminent and great initiates will work with the cosmos and its struggle between ice and fire.

The higher and total man, or 'Superman', will once more walk the earth's surface and that before him the 'slaves of Atlantis' will tremble.

This ancient, and yet somehow considered entirely new, concept viewing of the world was widely accepted by National Socialists. Working from this basis they would approach every matter from a 'Spiritual Aryan Science'. A science that has been called German or Aryan Physics and was headed by the brilliant German scientist Philipp von Lenard. He had published the four volume physics textbook titled, *Deutsche Physik*, and was named the chief of German Physics under the Third Reich.

In 1892 Lenard developed a cathode-ray tube with a thin aluminum window that permits the rays to escape, allowing the rays to be studied in the open. The Lenard ray was literally the mother of x-rays, laser beams and so on.

Lenard extended the work of Hertz on the photoelectric effect. Working in a high vacuum, he analyzed the nature of this effect, showing that when ultraviolet light falls on a metal it takes from the metal electrons which are then propagated in the vacuum, in which they can be accelerated or retarded by an electric field, or 'their paths can be curved by a magnetic field'. By exact measurements he proved that the frequency or color of light determined the number of electrons projected rather than the intensity or brightness of light. These facts conflicted with current theory. Again in 1905, Einstein presented his quantum theory of photons (light).

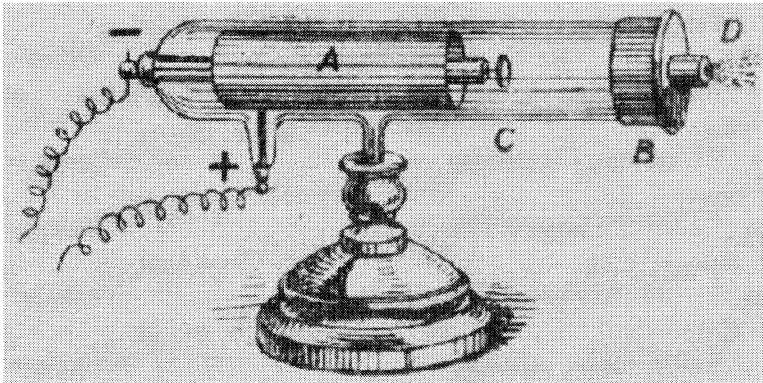

The Lenard Ray

Lenard despised Einstein for attaching his own name to Lenard's work. The enemy tries to isolate Lenard and his associate Johannes Stark as if they were alone in their animosity for Einstein, which is, far from the truth.

In 1929, the 'Deutsche Physik' movement issued the book, *One Hundred Authors Against Einstein*. It is a fact that Albert Einstein is an easily proven plagiarist, that is, to anyone willing to investigate the matter. Ernst Gehrcke, discoverer of the Anode ray, gave evidence that Einstein stole Paul Gerber's work by showing that Gerber had obtained precisely the same formula Einstein had derived using general relativity. Gerber's findings were discussed in a 1904 issue of 'Mach's Mechanik'. Einstein presented the same material one year later. In the 1878 edition of the Encyclopedia Britannica, Scottish physicist James Maxwell wrote an article suggesting that light was electromagnetic in nature. In the ensuing debate, the scientific community, particularly Lorentz, Michelson, and Morley reached the conclusion that the velocity of light was independent of the velocity of the observer. Thus, this piece of the Special Theory of Relativity was known 27 years before Einstein wrote his paper. Einstein was a 'patent clerk' who in 1905 presented 'his' theory of relativity. Even Nicola Tesla, who gave his research to the U.S. government and 'died' shortly after, publicly debunked Einstein and claimed his theories to be fraudulent and incorrect.

Here lies the whole basis of Aryan Physics versus Jewish physics, the Aryan's creative, experimental work in contrast to the Jewish speculator. Aryan Physics says nothing is definitive until proven. Jewish Physics upholds dry, unimaginative theories until absolutely proven false.

The Spirit of National Socialist Germany is an entirely different story. Let us take a look at just a few of their scientists. Carl Ramsauer, famous for the Ramsauer-Townsend effect, pioneered the field of electron and proton collisions with gas molecules. The renowned mathematician David Hilbert presented his '23 problems'. The father of the atomic theory, Erwin Schrödinger, whose work on the unified field theory was a forerunner to modern physics. Werner Karl Heisenberg was awarded the Nobel Prize in Physics in 1932 for the creation of quantum physics (Heisenberg also invented the Atomic bomb).

Ernst Pascual Jordan originated the quantum theory of fields, which we now take to be the basis of all physics. Walther Gerlach of the Stern-Gerlach effect who experimented with the spin polarization of atoms to generate plasma. These scientists, along with many other pioneers, were all National Socialists.

Quantum physics is the brilliant study of atoms, the minute particles, and the Divine Electron. In the face of Quantum physics the theories of Classical physics, such as, Newton's laws of motion and Maxwell's laws of electromagnetism, fail. The Quantum ocean has limitless possibilities, therefore, it teaches that once you think you have it figured out - you just lost it! Perhaps better said by Heisenberg in his Uncertainty Principle:

“The more precisely the position is determined, the less precisely the momentum is known in this instant, and vice versa.”

The Third Reich were pushing back the veil between, at least, two worlds. The Germans were only an implosion away from the flying discs that defy space and time. In his book, *Reich of the Black Sun*, Joseph Farrel puts it well when he writes:

“This left quantum mechanics as the only genuine physics that could equally be claimed to be Aryan and pursued by physicists with a vengeance. Quantum mechanics, in the state in which it then existed, could be summarized as having the following emphases and implications for the German scientists involved:

(1) The rejection of relativity meant to a certain extent that the pre-relativistic idea of an aether lumeniferous regained some currency, via its quantum mechanics version of zero point energy or vacuum flux. German scientists were therefore not free to pursue relativistic science, but were free to investigate the enigmatic properties of this new quantum aether. Indeed, with various esoteric and occult doctrines percolating in the background, such as the notion of ‘vril’ energy, and Reichenbach's early and well-known experiments in the 18th century on ‘life force’ energy, the Germans would have been positively encouraged by the underlying ideology to undertake experimental examination of its properties as far as existing technology would allow;

- (2) Reichenbach's experiments, plus the implications of Heisenberg's Uncertainty Principle, may have influenced German scientists to posit a connection between consciousness, quantum physics, and this underlying quantum aether. The strange Ahnenerbe experiments mentioned earlier would seem to indicate that some such experiments in consciousness were being undertaken;
- (3) Pre-war standard physics papers by Gerlach had indicated connections between spin and resonance effects;
- (4) The paradoxes of quantum mechanics had also become known, leading Einstein, Podolsky, and Rosen to posit 'quantum loopholes' in relativity's own 'velocity of light speed limit' for faster-than-light transference of information;
- (5) One German physicist of some repute, O.C. Hilgenberg, a student of gravitation expert Walter Gerlach, had taken Gerlach's work one step further, as we shall see;
- (6) German physicists thus had strong internal impetus as well as external ideological pressures to investigate the properties of rotating media and fields, especially since the results of Georges Sagnac's rotational version of the Michelson-Morley experiment were known to them;
- (7) The Germans knew of Tesla's extraordinary claims for beaming electric power, as well as of his high voltage direct current impulse experiments which revealed superluminal electro-acoustic longitudinal wave forms;
- (8) The Germans would likely have known of E.T. Whittaker's pre-relativistic papers, which were a mathematical study of such wave forms.

Given this series of known physical papers and experiments, and given the Kammlerstab's 'alchemy' of combining technologies and concepts to seek underlying unifying principles and methods, might they have put all these together to come up with the beginning theoretical outlines of a physics completely different than the public consumption physics proffered since the end of the war, up to and including, the 26 dimensional monster called 'String theory'? If so, are there any indications that they did so, or were beginning to? While the indications in terms of actual papers are slight, those indications, coupled with the

revelations that have come from Germany since its reunification, suggest that the answer to both questions is - yes.”

Farrel’s points clearly show a man whose mind thinks in terms of ‘Jewish physics’. Therefore, He cannot comprehend the psyche of a National Socialist, however, he does hit the nail on the head in his conclusion. Hitler never left a stone unturned. What Farrel and others identify as the Kammlerstab or the Kammler group had was the advantage to assemble the breakthrough discoveries taking place at several locations. The key is the S.S.

Within the SS there were groups working on the production of ‘alternative energy’. The Research Group IV or SS-E-IV had the main objective of freeing Germany from dependence on foreign nations. We will return to this SS technical group later. At the moment, let us keep to the ideal of ‘Aryan Physics’. The intuitiveness of ‘Aryan Physics’ may best be demonstrated in one man, Victor Schauburger.

The Austrian forester Viktor Schauburger had an esoteric knowledge of the natural world. Hence, his motto: ‘Observe and Copy Nature’. He was critical of ‘textbook theory’ and the arrogance and lack of imagination of ‘experts’. He refused to go to college, believing that he would lose his intuitive gifts. He found two forms of motion in Nature: outward, expanding flow that is used to break down, and inward-spiraling which, Nature uses to build up and energize. The balance between the attraction and repulsion of polarized atoms is the engine of creation. He turned this observation into a working apparatus named the Repulsine. He was advising at the Kertl Works in Vienna where his apparatus was reported to have actually blown through the roof of the plant. This was all was routinely reported to Hitler. In *The Hunt for Zero Point*, the researcher Nick Cook relays the following:

“A description of what happened when a Repulsine was rotated at 20,000 rpm. The high rotation speeds appeared to cause the air molecules passing through the turbine to pace so tightly together that their molecular and nuclear binding energies were affected in a way that triggered the anti-gravity effect. ‘A point is reached

where a large number of electrons and protons with opposite charges and directions of spin are forced into collision and annihilate with one another," Coats wrote. "As lower rather than higher forms of energy and the basic building blocks of atoms, they are upwardly extruded as it were out of the physical and into virtual states'."

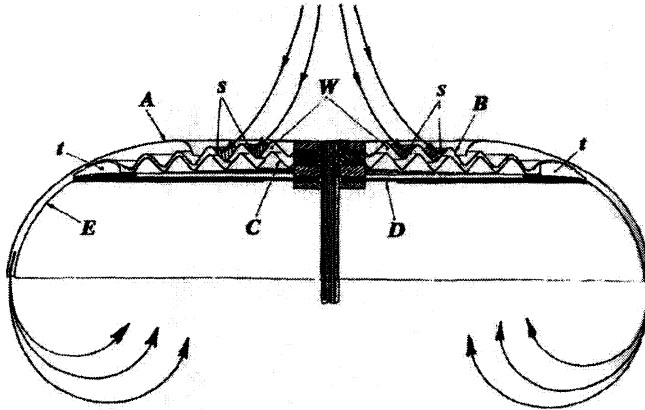

Schauberger Repulsine

If we now recall the vent intake system of not only the Miethe and Belluzzo, but also the Schriever and Habermohl designs, it is obvious where that brilliant technology originated. Schauberger is Lenard's 'Aryan Physicist'. He swore by the five elements of nature. His 'cold fire' known today as cold fusion, his proven Repulsine air intake system and so on, but it was his observations of water that he said held most promise.

"I stand face to face with the apparent 'void', the compression of dematerialization that we are wont to call a 'vacuum'. I can now see that we are able to create anything we wish for ourselves out of this 'nothing'. The agent is water, the blood of the Earth and the most universal organism."
- Victor Schauberger

On a side note, today's physics knows of a phenomenon named sonoluminescence. Sonoluminescence takes place when a small spherical glass is filled with water and then resonated by harmonious sound waves of 20 KHertz. Next a tiny air bubble is

blown into the center of the glass flask. When the air bubble is exactly 'centered' in the flask it starts to rhythmically implode and emit light. This light is emitted in ultra short light flashes representing trillion-fold concentrations of the original sound energy. Temperatures within the center of the bubble reach an astronomical height of 30.000 degrees Celsius and the pressure is immense! For us, this little experiment is verification that the 'Aryan Physicists' were light years ahead of conventional science, and still are...

We are certain of the flying discs programs, as sensational as they may be, are only the tip of the iceberg. In 1943, Schauburger's advisor position took a turn. He was inducted into the S.S. and performed his most secret work yet. By the Fuhrer's order the S.S. went underground with projects that would seem too fanciful to be true, that is, until we realize Zero Point Energy, Luminiferous Aether, Odal Force or Vril is the omnipresent.

In quantum physics, the energy that fills the cosmos is called Zero-Point Energy. Formless, faster than the speed of light, and omnipresent. Tachyon Energy is omnipresent, limitless and has all the potential information to create form. Tachyon energy is the gateway back to Zero Point energy. This is something that no frequency can do. All frequencies are just part of the whole, part of what is anchored in the Zero Point energy. This omnipotent energy is also known as the Aether or Vril. Vril spreads forth from the source, therefore, Vril leads us back to the source. An Implosion at zero point has limitless possibilities, such as, to propel infinitely, which, had been discovered by Hitler's Germany.

The SS-E-IV technical branch conducted research for an alternative energy. One of the projects they studied has been called the 'Tachyonator'. This machine, along with others, such as the Schappeller device, has a documented history.

The Tachyon converter of Captain Hans Coler, a German naval engineer, was tested at the University of Berlin between the World Wars under the watchful eye of Dr. Winfried Otto Schumann, discoverer of the Schumann resonances of the earth. It had no visible source of power and yet it made energy. The German Navy classified it as a possible source of quiet and limitless energy for submarine propulsion.

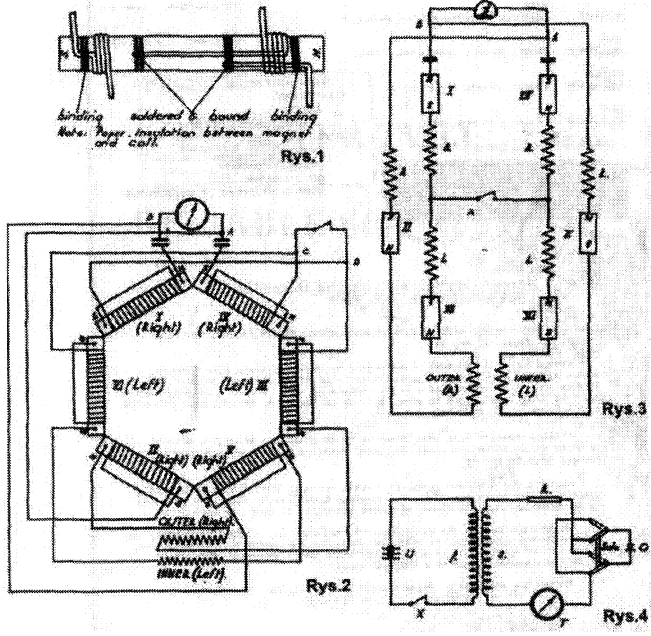

The Tachyon converter

It was at an S.S. presentation where Schumann was once reported to have said:

“In everything we recognize two principles that determine events: light and darkness, good and evil, creation and destruction; as in electricity we know plus and minus. It is always; either - or. Everything destructive is of satanic origin, everything creative is divine. Every technology based upon explosion or combustion has thus to be called satanic. The coming age will be an age of new, positive, divine technology!”

Dr. Schumann is a man of interest. It is claimed that he was a member of the Thule Society, but we have been unable to verify his membership. Nevertheless, the Schumann resonance was discovered during the Third Reich and only later, in 1952, did he inform the world. To understand the earth’s resonance or frequency makes the transfer of energy as simple as tuning in a radio station. It is also said that he developed an anti-gravity or

levitating device that has been coined the SM - Levitator. Henry Stevens tells us:

“What is unusual is that Dr. Schumann was involved with secret German research on ‘batteries’ as late as 1943, and was subsequently brought to the United States as part of Operation Paperclip. It was this same Dr. Schumann who had noted in 1926 that Hans Coler's device exhibited ‘no fault, hoax, or fraud on the part of its inventor.’ Such ‘free energy’ devices seemed to have come very early to the attention of the leadership of the Third Reich - witness the meeting between Hitler, Planck, and Schauberger - and more especially to the attentions of the SS.”

It is said that early in the war the special technical unit or SS-E-IV, made considerable advancements on the Tachyonator. This later Thule drive device was to be capable of Zero Point propulsion and installed in another branch of disc experiments. We must point out that these disc projects are less documented. As we continue forth, details become harder to verify, as one should expect.

Although there were different groups involved, the Haunebu crafts were always under the direct control of the S.S. technical unit. By this point, it becomes vivid how so many different programs fell under one S.S. umbrella. While the Haunebu engines were driven by an advanced Tachyonator, the bell like design is clearly of Schauberger origin. This is also where the presence of a hidden hand and the likes of the Vril and Thule societies cannot be denied. In *Disc Aircraft of the Third Reich*, author Rob Arndt expounds:

“This unit was tasked with developing both the Haunebu and Vril disc designs that utilized the world's first electro-magnetic-gravitic drive systems: the Vril and Thule Triebwerks. These drives relied on Hans Coler's free energy Konverter coupled to a Van De Graaf band generator and Marconi vortex dynamo (a huge spherical tank of mercury) to create powerful rotating electromagnetic fields that affected gravity.”

Arndt goes on to say:

“Thule found a location in Northwest Germany that was known as (or possibly designated as) Hauneburg. At the establishment of this testing ground and facilities the SS E-IV unit simply referred to the new Thule disc as a product - the "H-Gerät" (Hauneburg Device)...For wartime security reasons the name was shortened to Haunebu in 1939 and briefly designated RFZ-5 along with Vril's machines. At a much later time in the war as production of these craft was to commence the Hauneburg site was abandoned in favor of the more suitable Vril Arado Brandenburg aircraft testing grounds. Although designated as part of the RFZ series the Haunebu disc was actually a separate Thule product constructed with the help of the SS E-IV unit while the RFZ series were primarily built at Arado Brandenburg under Vril direction up to the RFZ-4 disc.”

It is not possible to document all of these claims, but up until this point information has been well verifiable. Anyone who leaves this chapter doubting the true origin of the UFO has not been paying attention.

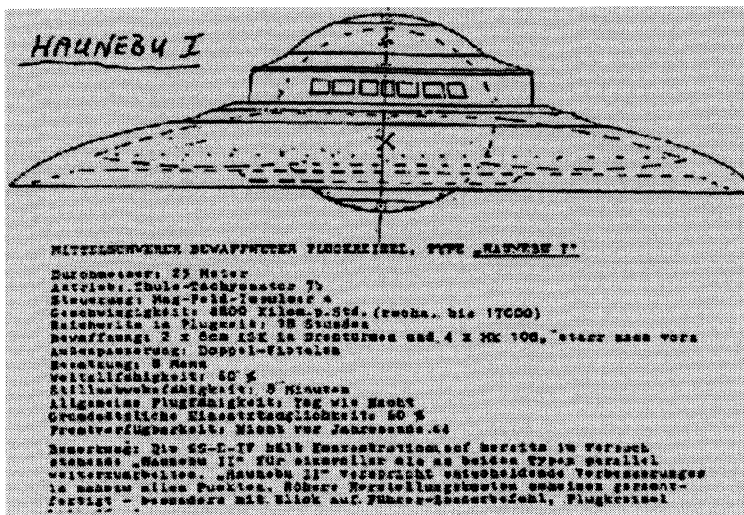

Moderately Armed Flight Gyro
 Diameter: 24.95 m
 Drive: Thule Tachyonator (Triebwerk) 7b

Control: Mag Field Impulser 4
 Speed: 4,800 km/h(theoretically up to 17,000 km/h)
 Range: Flight time of 18 h
 Armament: 2 x 80 mm KSK in rotating turret
 4 x MK-108 in body
 Armor: Double Victalen
 Crew: 8
 Hovering capability: 8 minutes
 All weather, day and night, capability
 Employment fitness: 60%
 First flight: 1939
 Available for service: 1944

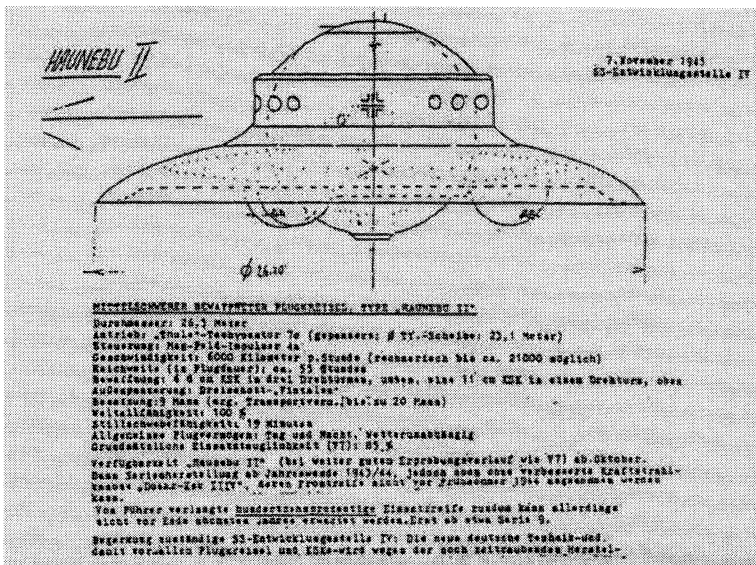

Heavily Armed Flight Gyro
 Diameter: 26.3m/ 32.0 m Do-Stru
 Drive: Thule Tachyonator (Thule Triebwerk) 7c
 Control: Mag Field Impulser 4a
 Speed: 6,000 km/h (theoretically up to 21,000 km/h)
 Armament: 6 x 80 mm KSK in 3 rotating turrets
 1 x 110 mm KSK in 1 rotating turret
 Armor: Triple Victalen
 Crew: 9 (with room for up to 20 people)
 Quiet flight: 19 minutes
 All weather, day and night, capable

'Final Battalion'

Employment fitness: 100%

First flight: 1942

Available for service: 1944

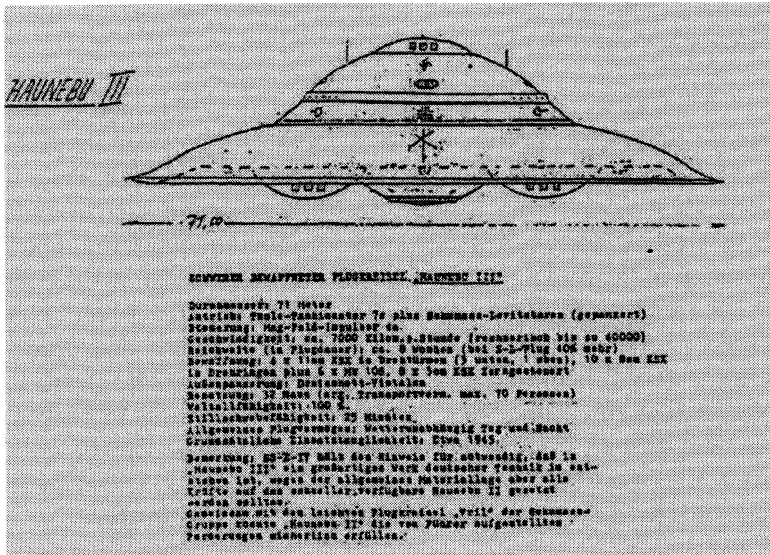

Heavily Armed Flight Gyro

Diameter: 71 m

Drive: Thule Tachyonator (Thule Triebwerk)

7c plus SM-Levitators

Control: Mag Field Impulser 4a

Speed: 7,000 km/h (theoretically up to 40,000 km/h)

Range: Flight time 7 to 8 weeks

Armament: 4 x 110 mm KSK in 4 rotating turrets lower/1 upper)

10 x 80 mm KSK in rotating turrets plus 6 x MK 108

8 x 50 mm KSK

Armor: Triple Victalen

Crew: 32 (with room for up to 70 people)

Quiet flight: 25 minutes

All weather, day and night, capability

Employment fitness: 100%

First flight: 1945

Available for service: 1945

In, *Time Machines* Norbert Jürgen-Ratthofer states:

“From May 1945, the Haunebu I, II and III space-going spinning-tops and even the Vrill 1 space-going flying discs disappeared, at first without a trace.”

This same author then goes on to tell of the bell shaped saucer phenomenon of the late 40's and 50's. He is not alone. In 'UFO's - Nazi Secret Weapon', Mattern and Friedrich make a good case in reference to the dozens of Haunebu shaped craft witnessed hovering in typical German formation over the Capitol building in Washington D.C. in 1952. The D.C. event is the type of occurrence that can make one wonder. The whole city observed the unexplained crafts. It is even claimed that orders were to shoot them down, as if, that were possible. It is hard to believe that any of the 'world governments' would be so brazen. Anyone who is familiar with the onslaught of bell shaped craft, after the war, knows there were just too many eye-witness accounts to deny some of these sightings to be legitimate.

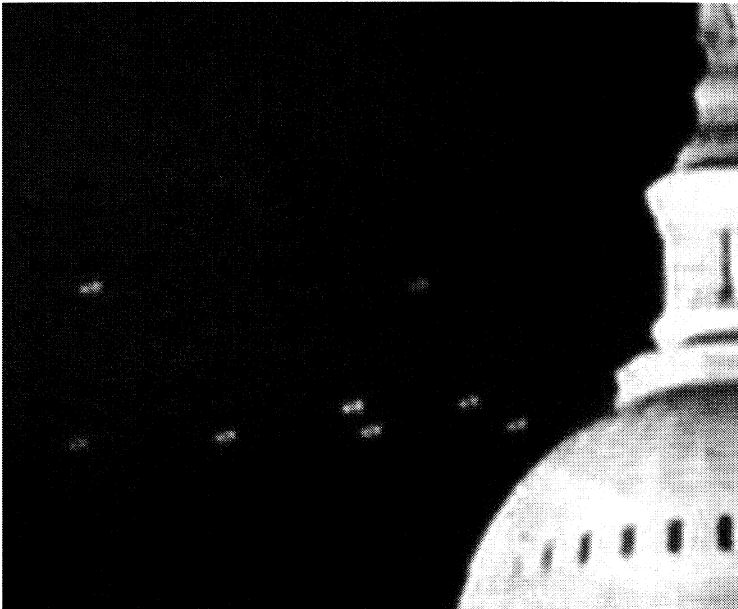

The Capitol building in Washington D.C. – July, 1952

Die Glocke

At this point, we have to ask what happened in 1943? If one is attentive they will realize there was a significant shift. The S.S. takes over 'all' secret projects, the Aryan Physics movement practically disappears underground, Schauberger begins his most concealed work, Dr. Oberth is just as mysterious, Lippitsch and Schumann are relocated and so on. This is the crucial moment in time. After the worst winter in over one hundred years, the Russian offensive fails. The harsh reality of possibly losing the war changes everything. The rats began to scurry, the warriors only fight harder, the Fuhrer sets in motion a contingency plan for the faithful and Die Glocke is activated.

There are many wonder weapons of the Third Reich that we will not delve into during the course of this book. There were too many to mention, for example again, the 'Foo Fighter,' which documents that have been unclassified show the Allies had always known they were a German apparatus. But we must take a look at 'The Bell' (Die Glocke). It is worth reading what Cook writes when pondering upon the Bell:

"Something about this whole strand of development had conspired to make it the most classified form of technology in existence. Even more so than the bomb...Unlike the bomb, however, this was a secret that had held for more than 50 years."

The only time our Governments leak *nothing* is when they do not understand it themselves. When they know; they lie.

The S.S. General Hans Kammler was highly efficient at engineering underground facilities. He directed many of projects because of this fact alone. He oversaw the subterranean facilities that housed the Bell. It appears that the director of the Bell project was the famous physicist Walter Gerlach. There is also evidence of Oberth and Schauberger having a hand, amongst a host of others. There are many speculations as to what the Bell actually was. An anti-gravity device, time machine, nuclear fission and so on.

Die Glocke (also called the Charite Anlage) was first brought to the attention of the public by the Polish researcher

Igor Witkowski in his book *The Truth About the Wunderwaffe*. Since then, a wide range of speculation and fantastic stories have surfaced. There are those who believe the Bell was nothing more than German genius in the construction of the Atomic bomb, such as, Simon Gunson who wrote:

“The Bell was a plasma induction coil, designed to irradiate compounds of Thorium and Beryllium to transmute Thorium and breed Uranium from it using a photo-chemical process. Prior to WW2 Professor Walther Gerlach had experimented with the spin polarisation of atoms to generate plasma. In 1936 another scientist Dr Ronald Richter had experimented with electric arc furnaces smelting Lithium for U-boat batteries and discovered by injecting Deuterium into the plasma that he could create nuclear fusion...The Bell expanded on these two insights by spinning mercury in a powerful magnetic field to cause a plasma which excited Beryllium to release Neutrons into Thorium at the core of the machine.”

Then there are the conspiracy theorists who want to believe practically anything they hear. Jim Marrs would fall in this category yet he does make one wonder when he writes:

“From the Arnstadt documents it is clear that the Charite Anlage unit operated in a three-story underground bunker with floors 70 by 20 meters...When working, the device emitted some kind of energy field which shut down all electrical equipment and non-diesel engines within a range of about eight miles. For this reason, even though Ohrdruf was crawling with SS, it was never photographed from the air nor bombed. Declassified USAF documents dated early 1945 admit the existence of an unknown energy field over Frankfurt/Main and other locations which fantastic though it may appear were able to interfere with our aircraft engines at 30,000 feet.”

The National Socialists of Germany had more hidden bases than the outside world will ever know. The Bell seen a few of them. So that one may understand just how far advanced their researching was, let us focus on the ‘supposed’ last home of the

Bell during the war, 'Der Riese' or the Giant. Der Riese was an old mining system named Wenceslas Mine near the village of Ludwidsdorf located in what is known as the Owl mountains. The Germans had seven known independent yet connected underground programs in the mines. They were, at least, mining, refining and researching 'uranium' from this one location and this one location also housed Die Glocke and her scientists. But we still haven't answered what the Bell actually was.

Knowing what we know, tell us it was an implosion apparatus. The question is implosion for what? In *Manu – for the coming man*, Master Serrano reveals to us something of great significance:

“These people are atomic scientists and their research is carried on in the most advanced center of this country, perhaps the most specialized in the present world. They told me the atomic bomb does not exist. ‘And Nagasaki, or Hiroshima?’ I asked them. ‘Those were Hitler’s bombs,’ they replied, ‘those the Fuhrer did not want to use against England, Russia and the United States. He had five bombs ready for that’...The true discoverers of atomic disintegration were the professors Werner Heisenberg and Otto Hahn. With Heisenberg worked Carl Friedrich von Weizacler and Frisch, both went over to the enemy side, with their previous knowledge...I insisted: ‘And the French atomic blasts on Bikini atoll, in the Pacific?’ ‘They’re explosions *in situ*, underground,’ they answered. ‘Only the Hitlerists were capable of inventing and manufacturing a bomb transportable through the air, that can then be detonated. Hitler did not want to use it against his enemies. Those bombs fell into the hands of the Americans. One of them was tested in the Nevada desert; another over Nagasaki and a third over Hiroshima. Two more were still usable and were saved to use against Germany, in case she did not yield before the dictates of her conquerors. Germany, divided in two, still did not have a peace treaty and remained an occupied territory, obedient and servile. She still had to acknowledge the holocaust of 6 million jews by Nazi Germany and pay indemnification until the year 2000, and beyond, knowing all of this was a fraud and extortion. Germany feared

the holocaust would be realized in her...(This conversation took place in 1983.)”

We find this scenario very interesting since it coincides completely with the otherwise nonsensical Israeli threat. To those who may not know, the Israelis have ‘the Samson plan’, which consists of bombing Europe with nuclear weapons if they should ever see on the horizon their own demise. This threat hasn’t ever really made any sense, that is, until we look at it under the light of Serrano’s revelation. Let us go back to Master Serrano who expounds more on the matter:

‘The revelation I heard was so incredible that I had to force myself to accept I was meeting with scientists of the first rank, and above all with Germans, who do not know how to lie and, therefore, must be taken seriously. I investigated the difference between a test *in situ* and an explosion in the air. Various technical explanations were given that can be summarized as the difference between explosion and implosion. Which is to say, to make an atomic bomb like that of Hiroshima enriched uranium is required, provided only when very high temperatures and pressure are reached. To enrich uranium temperatures are required that only the science of implosion make possible. And the Hitlerian scientists would recover this old, almost magical, or simply magical, science.’

The atomic bomb was one of the many by-products of their implosion research. Hitler did not even want the bomb, if he did he would have put it to use. This revelation is beyond the scope of reasoning for many because they cannot comprehend the mindset of a National Socialist. In fact, those who scoffed at what Miguel Serrano said 40 years ago, now pretend as if they have discovered something new. Alas, it is a learning experience. It is hard at first for anyone to believe, that is, until the pile of facts becomes undeniable.

We are entering into an undeniable higher consciousness. The Bell was a device to defeat time. Once we overcome the chains of gravity, time and space; nothing is impossible. Let us

not get ahead of ourselves. We may conclude in this train of thought with another statement by Henry Stevens:

“Dr. Jesensky and Mr. Lesniakiewicz assembled and analyzed the great volume of evidence they had gathered over the years. From the thousands of observations and facts collected, they tried to draw conclusions. They found a close proximity and close association of the German nuclear program to the German flying saucer program.”

And there we have it: the centripetal force needed to make spaceflight a tangible reality. The device worked on torsion of space-time by rotating drums in opposite directions (in a very 'Mercurial' type of manner) filled with a 'mystery serum'. The mystery serum has been coined 'red mercury'. Today red mercury is said to be the powerful agent in a 'dirty bomb' or a suitcase nuclear bomb. We believe this to be a smokescreen meant for the masses.

What it is, is an efficient tamper, making possible the successful implosion fissioning of miniscule amounts of Plutonium. Plutonium is produced from Uranium...

“It is Mercuric-Stybic Heptoxide - $Hg_2Sb_2O_7$. Its crystalline structure has a lattice of little hollow spaces, into which plutonium atoms fit snugly. The heavy atoms of Mercury and Antimony reflect back neutrons into the mass at the same time they hold the plutonium while it is fissioning, by inertia of their heavy nuclei having too tremendous momentum by their implosion of a shell lined with $Hg_2Sb_2O_7$ saturated with Pu, using immense electromagnetic fields generated by explosive Flux-compression generators, giving many times more velocity and hundreds or even thousands of times more energy density of implosion, than any chemical implosion technique ever could.”

- George Paxinos

In other words, they had discovered that by oscillating this radioactive Mercurial substance in a unique way would create a vortex or Vacuum strong enough to create an 'Axion' field capable of bending space and time. Farrel has made the claim:

“Whatever the mysterious substance was, it seems clear that it was highly radioactive, and that the Germans were subjecting it to extremely high mechanical and electrical rotations to study the resulting field effects; effects that Cook's advisors could only qualify as ‘torsion’ fields. These fields are thought by some contemporary physicists to have direct relevance to the study of gravity, and of time.”

Indeed they do, but not for the purposes that the materialists would use these type of discoveries for. Before it is over, they will claim that the Germans sent an elite force to a later time and are in the future waiting, etc. Towards the end of the war the Fuhrer had said “It would seem that we must take this fight to Hell itself.” The Germans were not interested in a ‘time machine.’ They were interested in dimensions, that is, the Land Beyond the Poles.

As incredible as it may seem, the V7, Flugskeisel, Peenemunde and ‘Operation Paperclip’ - as far advanced as they may have been, were all carefully given up to the enemy. The real discoveries were far greater than any of these projects and are ‘spiritual’ in nature. Therefore, they are hidden from the children of mammon. We are not saying that the Allies didn't eventually catch on, but by then it was already too late. The Bulgarian physicist Vladimir Terziski says it well:

“The Germans had probably 50 models of flying saucers powered by every existing engine in their arsenal... On top of the saucer space flights the Germans had an extensive space program with rocketry. (Take note that both the American and Russian space programs depended on the German scientists they both acquired following World War II.) It is possible that these researchers were intentionally made-out to be the ‘cream’ of German aerospace science, when in fact the most intelligent scientists may have found their way to the Antarctic base following World War II.”

What few have understood is that the Kammler group received orders. They were only a finger of the hand. The S.S. is

the key. One must keep in mind that the S.S. swore an oath of Loyalty to the Fuhrer. While most faltered – there were those who kept their Troth, that is, Hitler’s Final Battalion.

Again, one must come to understand the differences in thinking. The two opposing psyches that exists between the Spiritual and the material, Aryan physics vs. Jewish physics, or the esoteric in comparison to exoteric. What a grand justification for the traitor when fooling himself, too many could not see why Hitler would not use these phenomenal weapons to ‘win the war’. We can still hear their cries of exasperation; “is he trying to lose the war?” In the end, it comes down to a mixture of Faith and Loyalty. It is defined as Troth and for the Aryan, there is no higher quality.

The hidden motivations for such decisions only make sense when we look into the heart of the matter, and it is a spiritual matter. It is a spoken truth when they say that National Socialism is a religion. It is the ancient religion of the Hero Myth made anew. It is made up of those things that the ‘slaves of Atlantis’ will never comprehend. And it is the creative ‘Spirit of Genius’, the God of Honor and Goodness, who is behind those ideals, which gave the previously mentioned ‘technologies’ life.



An illustration of 'Die Glocke'

'The Esoteric or Divine Science'

To grasp the complexity of the esoteric reality of the Third Reich, and all its ramifications, we must go backwards and look into a can of worms that would probably be better left alone. To ever make any sense out of the layers upon layers of extreme espionage and betrayal against the honorable and loyal; we first need to understand the enormous scope of treason within these hidden circles. Only then will we see the Faithful.

The esoteric and espionage have gone hand in hand since the very conception of 'official spying'. Our story begins in the late 1800's with the 'Oriental Templar Order' (O.T.O.).

"The Hermetic Brotherhood of Light was a mystical society which claimed descent from the late 18th century Austrian Masonic/Rosicrucian body known as the *Fratres Lucis*. The *Fratres Lucis*, also known as the Asiatic Brethren or Initiated Brethren of the Seven Cities in Asia, was derived from the earlier German Order of the Golden and Rosy Cross. The Hermetic Brotherhood of Light also appears to have had connections with the Hermetic Brotherhood of Luxor. In 1895, Carl Kellner began to discuss his idea for founding an *Academia Masonica* with his associate Theodor Reuss. During these discussions, Kellner decided that the *Academia Masonica* should be called the 'Oriental Templar Order.' The occult inner circle of this Order would be organized parallel to the highest degrees of the Memphis and Mizraim Rites of Masonry, and would teach the esoteric Rosicrucian doctrines of the Hermetic Brotherhood of Light, and Kellner's 'Key' to Masonic symbolism. Both men and women would be admitted at all levels to this Order."

- T. Apiryon – O.T.O.

After the death of Kellner, Theodore Reuss became the sole founder of the O.T.O. Reuss knew a large variety of players. During his time in England he became acquainted with Aleister Crowley, who later became a member. In Germany, Heinrich Traenker served as National Grand Master of the German O.T.O. under Reuss. In 1921, Traenker founded the Pansophia Lodge –

Orient Berlin. After the death of Reuss it was Traenker who received his personal library.

In 1925, Traenker and Crowley (Crowley was a secret British agent) had a terrible falling out. Traenker made the later remark about Crowley: "He did not aim towards God, as did the old Rosicrucian way." Traenker was quite correct. Crowley was a degenerate. The Pansophia Lodge absolved over the split.

In 1930, the 'Reichsarbeitsgemeinschaft' circulated a pamphlet titled 'Vril – Die Kosmische Urkraft'. It said the group was formed in 1925 to research the use of Vril and free energy devices described as ball shaped power generators with 'psycho-physical technologies. It mentioned the reform and continuance of German Rosicrucianism. A second pamphlet was published by Otto Barth. Barth and Traenker were close associates. The terms in both pamphlets were identical to that of the Pansophia Lodge. Theo Pajmans, in *John Keely, Free Energy Pioneer* claims that the 'Reichsarbeitsgemeinschaft' thought of the earth as having "the same structure as an apple sliced vertically in two halves". The German space rocket novelist Willy Ley would poke fun at this very same idea. He claimed this thought to have originated with the Vril Society, and for once in his life - he was right.

The Vril Society was made up of various factions. The speculation of General Karl Haushofer having a leading role in the Vril has weight when we realize that his Luminous Lodge was originally named the Brothers of Light, which is to say, the Hermetic Brotherhood of Light. When Master Serrano tells us that men, such as, Haushofer and the 'Thulist' von Sebottendorff were used by military intelligence agencies, he is referring to the O.T.O. via Golden Dawn, along with the Masonic Lodges.

The two greatest factions of treason in the Third Reich were the leftist, socialists (Gregor Strasser type), and the upper echelon Masonite (the Admiral Canaris sort). In reality they were one and the same, because both served the enemy's interest. The night of the long knives quelled the Strasser type, but it was the intrigue and espionage of the quasi-esoteric circles that cost Germany the war.

If only Philipp Stauff (member of the Germanenorden) had survived his 'suicide', perhaps events may have been different. Stauff was naming names and exposing crypto-jews and their

'Final Battalion'

sympathizers in the highest of places and oldest of families that had become imbedded with infiltration. It cost him his life. The terrible hidden power of the blackest hand had to reveal itself with his 'suicide'. He was getting too close.

Rudolf Hess was a student of the legendary Haushofer. They're admiration for one another demonstrates well the entanglement. Hess was a member of the Thule Society and Adolf Hitler's most loyal friend. Haushofer was affiliated with the O.T.O. and Golden Dawn - his son was executed for treason.

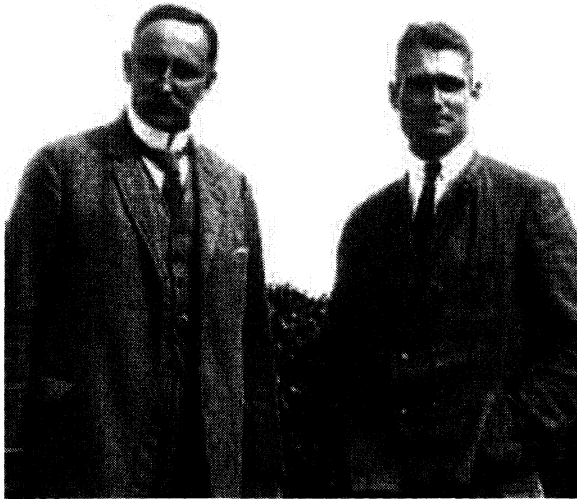

Haushoffer

Hess

It should be said in the defense of Haushofer, that after his son's treason and his earlier involvement in the loss of Rudolf Hess, by the intrigue of the esoteric circles of Britain, that he still remained unmolested. This protection must have come from the Fuhrer, himself. It should be noted that Hess was not fooled and knew exactly what he was getting himself into. He still felt what was one man compared to a treaty with England. He took the risk. The double dealing of these quasi circles that lured Hess on that doomed flight made Hitler proclaim "never again!". Adolf Hitler outlawed all esoteric societies. Any loyal groups that remained were incorporated into the S.S. This would even include women, such as, the Vrilerinnen. The year was 1941.

The All German Society for Metaphysics

“Somewhere the true Feminine Order of the Priestess-Magas of Esoteric Hitlerism has been organized (with those Women who deliver Health and Salvation) accompanying the Warrior-Heroes of the Fuhrer and the Ultimate Avatar. And the Man to Come”

- Miguel Serrano

The Vrilerinnen have literally become a cult of their own. The stories that continue to develop are quite fascinating. The major obstacle is in the fact that it is difficult to verify much of the forthcoming information. The Vrilerinnen are veiled in secrecy. What lends credence to ‘The All German Society for Metaphysics’ (the Vrilerinnen) is in the way the pieces all come together. Only initiates of the highest order could possibly fabricate such a tale. There are too many hidden truths that weave into one fabulous conclusion.

The story is that a group of National Socialist women received, through their Blood Memory, information on how to construct an inter-dimensional space flight ship. They had instruction (knowledge) on the divine science of implosion. This in turn was investigated by learned men to confirm it’s plausibility. It was confirmed.

To start at the beginning, Maria Orsic was born in Vienna, or at least her mother was from Vienna. Her father, and Orsic Castle in Croatia, complicate her exact whereabouts as a child. The point at which sources agree is that she was a member of the German National Movement of Austria. The German National Movement cannot be stepped over as it has been so many times in the past, for in it are the answers to who Maria Orsic actually was and what she represented.

Georg Ritter von Schönerer a.k.a. the Knight of Rosenau, was the Leader of the German National Movement. He also founded the famous Linz program and its 12th article, which read as follows: “The removal of Jewish influence from all sections of public life is indispensable to carrying out the reforms aimed at.”

Von Schönerer was a relentless fighter who never let off the Jews whom he held to be responsible for the demise of German culture. He had won the respect of many German Austrians. One

'Final Battalion'

of these admirers from the town of Linz was the young Adolf Hitler. There have been claims that this was the early beginnings of National Socialism, especially when we consider how many personalities of the Aryan awakening came from Austria. The point to be made here is that Maria was a true National Socialist from the very start. She was the indisputable leader of the Vrilerinnen and absolutely loyal to her Fuhrer. Maria would move to Munich.



Maria Orsic

Maria's closest confidant was the Vrile Maiden known as Traute (usually a nickname for Gertrude, which derives from Erda). Both were Austrian and raised Roman Catholic. By all accounts, the two shared a great understanding and respect for one another. It is said that Traute was a student of Professor Schumann at the Technical University of Munich.

We have no way of verifying the established pictures for these ladies, but it really does not matter. It is not so important when and where they were born, how tall they were or when they left Germany, etc. because what is important is the idea. The idea is sound. These women and their mission existed.

55 Club

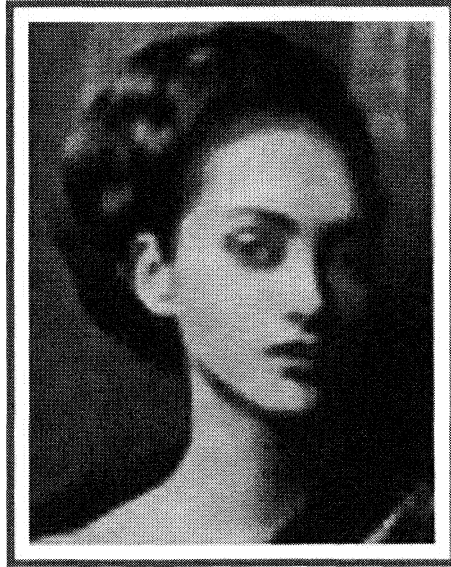

Traute

Causa Nostra (who are *not* National Socialists) claim that it was not until later when the younger 'Sigrun' arrived. Said to be the daughter of a Junker, it is claimed that she actually test flew flying discs. This may seem fanciful, that is, until one recalls the famous Third Reich test pilot, Hannah Reitsch. Hannah was not only the first woman in outer space, she was the first person ever in outer space. It was Hannah who flew the last plane out of Berlin after leaving the Fuhrer's bunker.



Sigrun

Hannah

The Ladies of Vrill were organized with the support of the Thule Society, for they, too, were fighting against the 'progressive' times and decaying culture. The inner circle were staunch Traditionalists who wore a horse-tail hairstyle, and yes, they were of a spiritual nature. Reminiscent of the 'seahorse', there is much to be said of the symbolism that the women chose. These are the Ladies who inspire men. Master Serrano would certainly have identified them as Hyperborean Priestesses.

In his book, *Black Sun - Aryan Cults, Esoteric Nazism and the Politics of Identity*, Nicholas Goodrick-Clarke relates to us a meeting where it supposedly all began:

"In August 1917, according to Jürgen-Ratthofer and Ettl, Rudolf von Sebottendorff, Karl Haushofer, the medium Maria Orsic from Zagreb and the pilot Lothar Waiz held a meeting with the old prelate Gernot of the Societas Templi Marconi at a café in Vienna...Gernot was highly impressed and invited Sebottendorff to visit the secret estate of his Templar order known as "Die Herren vom Schwarzen Stein."

We are confident this 'meeting' took place and that the information is basically accurate, but we should also keep in mind that the apparent origin of this information are the writings of Sebottendorff, in which, he is always the star.

His book, *Bevor Hitler Kam*, was actually banned by the Third Reich. Sebottendorff fell from grace with the capture and execution of several Thule members at the hands of the communists. Many held Sebottendorff responsible, nevertheless, showmen usually do have a part to play in organizing others.

So with that said, it is claimed that Maria had brought information to that meeting which had been received by the Vrilerinnen. Information that was written in 'Templar code' and perhaps even the plans for an inter-dimensional apparatus; enter the prelate Gernot.

Gernot is of great interest here. This man represents the faithful custodians of a great secret tracing back to a sect of German Templars who made their residence at the mystical Untersberg Mountain. We shall speak more of this later. As for

now, our concern is the message of the Vrilerinnen. Jan van Helsing gives his summary of that information:

“I would like to present here a short summary of the messages the Vrile medium had received over the years and which formed the basis for all further actions by the Vrile-Gesellschaft:

‘The solar system Aldebaran has a sun around which revolve two inhabited planets that form the empire Sumeran. The population of the Aldebaran system is divided into the master race of ‘light God people’ (Aryans) and several other human races that had developed by negative mutation from the ‘God people’ because of climatic changes upon the planets. The colored mutant races apparently are on a lower stage of spiritual development. The more the races intermixed, the lower the spiritual development of these people sank, which led to the situation that when the sun Aldebaran began expanding they could no longer maintain the space travel technology of their forefathers and could not leave the planets by their own means. The lower races, totally dependant upon the master race, had to be evacuated and were brought to other inhabitable planets. Despite their difference all the races respected one another and did not interfere with each other, neither the so-called God people nor the lower races...

after the expansion of the sun Aldebaran and the resulting heat had made the original planets uninhabitable. It is said that in our system they first colonized the planet Mallona, which existed in the area of today's asteroid belt, then between Mars and Jupiter...The Vrile people thought that later, when Earth became slowly habitable, the race of the Aldebarans landed in Mesopotamia and formed the master caste of the Sumerians which were described as fair, white God people.”

We're not sure where Van Helsing attained this explanation, but we do know if it is legitimate, then it is in code. The truth is much closer to home. To put it plainly, it is the story of earth.

For some it might come as a surprise that the Sumerians never used such a term to describe themselves. The word ‘Sumerian’ was labeled by Semites. They called their language Emegir and called themselves the ‘saḡ-gig’.

The Sumerians left behind legends about the Gods and their earlier settlement as told in the 'Barton Tablets'. These tell of a land of the Gods which at one time became frozen and cold, and eventually forced them south. They called this place Karsag.

This same legend is also told in the Avesta of the ancient Persians of Iran:

"At that time Airyana Vaejo had a pleasant climate, with 7 months of summer and only 5 months of winter. The forests were rich with game and the fields with grains. In the valleys many brooks flowed. This land however turned into a cursed land, where for 10 months it was winter and only 2 months was it summer, following the attacks of Ahra-Majnyu (evil-devil)."

It is known that the ancient Iranians cohabitated with the 'nomadic' Alan peoples. Both names derive from the word Aryan. The Romans would later write of the fierceness of the Alans; who had a blondish hair and were known for their large stature and beauty. The Alans were also known over the course of history as the 'As' and the 'Os'. This is an obvious reference to the divine Asa of the Northmen and part of that long trek from the original Arctic home. The migration may have taken thousands of years to reach Mesopotamia, where they created 'the cradle of civilization'. In 1961 Transylvania, clay tablets were found with early forms of Sumerian writing at least 1,000 years older than any Sumerian writing found in southern Mesopotamia. They did not land in Mesopotamia. They migrated there after the spiritual catastrophe of the Great North at Thule, Hyperborea.

The degenerated race of the Gods who are trapped in a lower, spiritual vibration are us. The two worlds are the two earths that are separated by dimensions. The Land beyond the Poles is Aldebaran and there is where we shall find salvation. The Paradise that Blake lost, Adolf Hitler found. There is one train of thought in Van Helsing's summary that is plain truth enough; the Spirit of the Aryans is not from this world.

The Vril Priestesses received information on the principle of divine implosion, therefore making possible inter-dimensional travel and anti-gravity flying discs a reality. But let not the

disbelievers take our word for it, let us look to the mentor of the very director of NASA. The ever mysterious Dr. Hermann Oberth had once made the remark:

“We cannot take the credit for our record advancement in certain scientific fields alone; we have been helped.” When asked by whom, he replied, “The people of other worlds.”

To bend space could create a time paradox, in which, we honestly do not know what is the truth of the ‘reality’ we are living in. In the end, it will come down to who were faithful and true, as for the rest, they will have failed their mission.

In 1921, the Vrilerinnen officially became known as ‘The All German Society for Metaphysics’ whose purpose was to discover alternative energy and the origins of the Aryan race. The struggle continued. As Hitler rose to power, they rose in power. It is said by 1937 they purchased a castle in the Bavarian Alps, renaming it ‘Asgard’. Around the same time Vrili acquired flatlands, for testing, at the Arado-Brandenburg aircraft facility, but we are of the belief that their most secret work was conducted in Bavaria, hence, the later tale of a 1936 ‘UFO’ crash in the Black Forest.

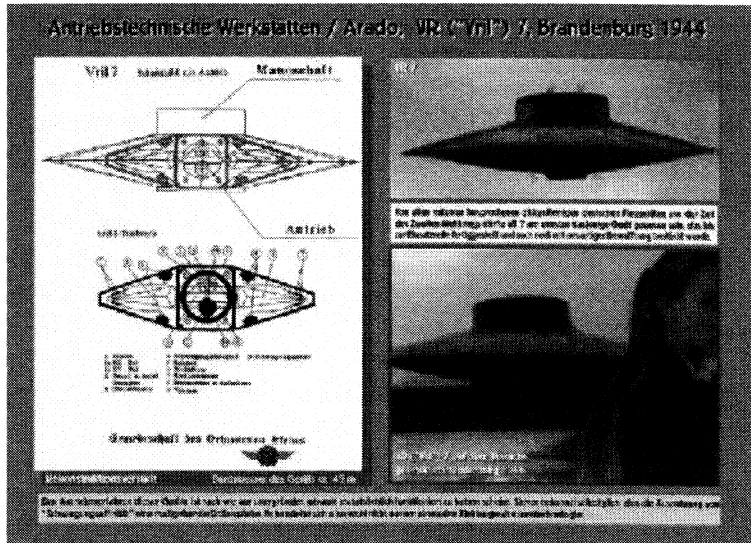

It has been 'claimed' that the Vrilerinnen were sponsored, by of all people, the traitor Admiral Canaris. We know that Canaris may have single handedly cost Germany the war by doing all he could to keep Spain's President Franco 'neutral', thus blocking the way to Gibraltar. If we once again consider the high level of 'esoteric' treason in the Third Reich, we can only arrive at one conclusion about the Vrilerinnen.

The situation in Germany was such; by the time a new weapon was operational, the Allies already had the blueprints. For example, no sooner than Die Glocke had tested successfully, Einstein and his band of Jewish scientists were bumbling about at the 'Philadelphia experiment'. This was the reason for the 'strange behavior', such as, disassembling and boxing in crates a new technology once it completed testing.

The only feasible explanation for the inter-dimensional discs being kept secret from the Allies was the absolute loyalty of the Vrilerinnen.

Master Serrano says as much in his epic, *Adolf Hitler, the Utimate Avatar*:

"The Hitlerists had built a *Vimana*, a *Star*, that flying object the 'Ramayana' and 'Mahabharata' as well as Homeros tell us about, and 'that was driven by a melodious sound (*Mantra*) and that could read the thoughts and feelings of men'...Those who left in their *vimanas*, in their UFOs, took the secret unknown weapons with them."

We are of the belief that Maria and company were loyal to the Fuhrer and go as far to say they were probably reporting on their 'handlers'. Otherwise, the Allies surely would have had these technologies and they did not. A divine science they still cannot fully comprehend.

Regardless of what one may think, the space flight discs were a reality. It is too well documented to deny.

To sum up the Vrilerinnen, and the efforts they contributed to the S.S. research for the development of ancient technologies made anew, we here present a sufficient list of supposed Vril disc projects compiled by a fellow named William Bacon:

Electrogravitic Craft Based on Currently Unknown Physics

- 1.** Original Vrill Society Craft. Said to be a 'time machine', it underwent two years of experiment. Dismantled early in 1924 (!) and shipped to Augsburg. The design was said to have been based on channeled information from a supposed planet orbiting the star Aldebaran (Alpha Tauri). Disposition unknown.
- 2.** RFZ-1 (RFZ = Rundflugzeug = round aircraft). Disc created in mid 1934 by Vrill Society. Crashed from low altitude on first test.
- 3.** RFZ-2. Completed at the end of 1934 by the Vrill Society. Length was 16 feet, and it was the first with 'magnetic field impulse steering'. It was operational in 1940 as seen in a photograph taken over an ocean, said to be the South Atlantic.
- 4.** RFZ-4. A test craft driven by propeller to study the aerodynamics of a disc-shaped craft. Associated with Schutzstaffel (SS) unit E4.
- 5.** RFZ-5. Also known as Haunebu I (note: Nebel=haze or smoke). Flew 08/1939. Diameter 83 feet. Photograph exists, said to have been taken over Prague. With a crew of eight, said to have reached 12,000 mph and upper atmosphere. Claimed to have been equipped with two laser (apparent anachronism) guns.
- 6.** RFZ-6 (Haunebu II). Work began before the end of 1942. Various shapes, 85 feet to 100 feet in diameter and 30 to 36 feet high, were produced. A 3200 knot speed is assigned, making for near-space capability. One plan shows a Donar Ray Gun (!) in a turret on the underside. Some had sleeping quarters. A deep-space variant was said to be 234 feet in diameter. At least one side-view drawing with data survives and it bears an uncanny resemblance to an orthographic projection which has been made from the famous Adamski and Darbishire UFO photographs.
- 7.** Haunebu III. An SS E4-planned deep-space disc craft. Various photographs show design variations. Over 400 feet in diameter. A side view drawing with data survives. Reportedly, U.S. found none. A Haunebu IV also is reported.
- 8.** Andromeda Project. A large craft planned by SS E4 for interstellar travel, over 100 ton capacity. 360 feet long.

'Final Battalion'

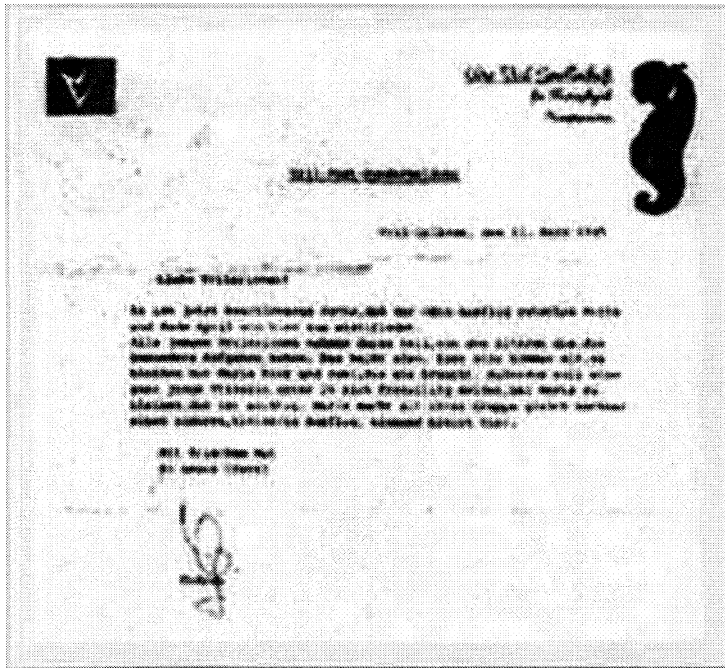

Late letter addressing departure plans - with rough translation below.

Vril-Thule-Institute for Metaphysics

Vril College, March 11 1945

Dear Vrilerinnen!

... the Odin-trip is between mid-March and April ... To all the splendid young Vrilerinnen, from the Elders, a request has come. Two then. First, they all come here to stay with Maria, and second, they need also to give time, the young Vrilerin under 24, to volunteer soldiering. to stay on with Maria, that is, with Maria ... the same group a different Aldeberan trip.

No one is staying here.

With Cheerful Courage, Godrun

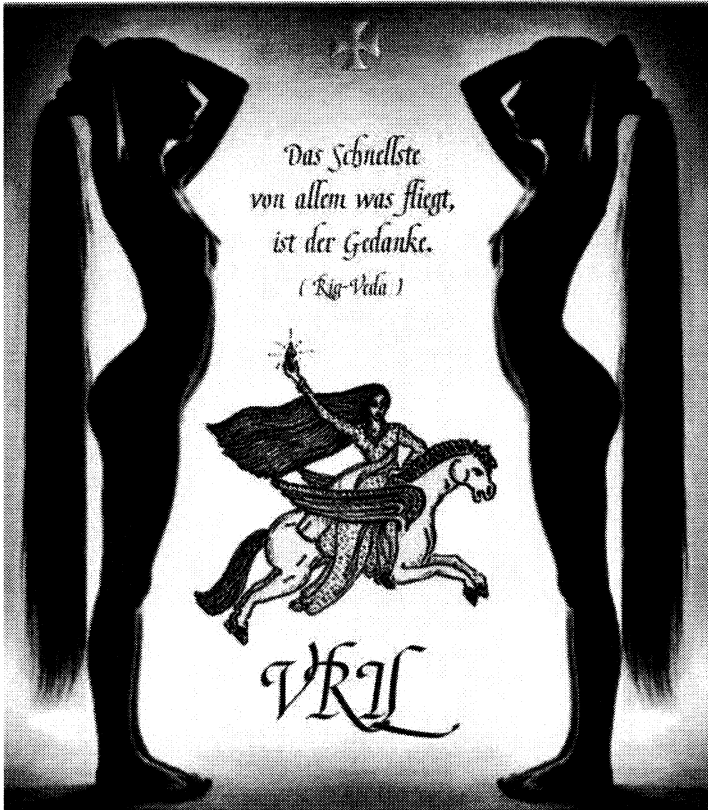

“That which flies fastest is the thought” (consciousness).

The above quote was taken from the *Rig Veda*, which was written in Sanskrit. The word Aryan, just as Swastika, actually comes from the Sanskrit language. The Vedic Aryans of India, who founded the religions of Hindu, Persian, Egyptian, Bon, and so on (also the caste system), were at the very heart of National Socialism along with their Nordic roots. The Eddas and the Vedas both originated in the Arctic North in pre-history.

The eye catching photo also exhibits Isais upon Her flyer or winged horse. Isais is also holding Her Stone and Mirror, which shines of God’s truth. It is a guiding light through the darkness. Thus, the Stone and Mirror provide a description of Her mission, a mission and purpose that lived in the heart of each Vrilerinn.

'Final Battalion'

Anyone who studies 'The German Society of Metaphysics' and their 'Ahnenerbe' mission of ascertaining 'free energy and the finding the origins of the Aryan race' will come to the realization that these women were working on the rediscovery of the Vimana, presently known as the U.F.O.

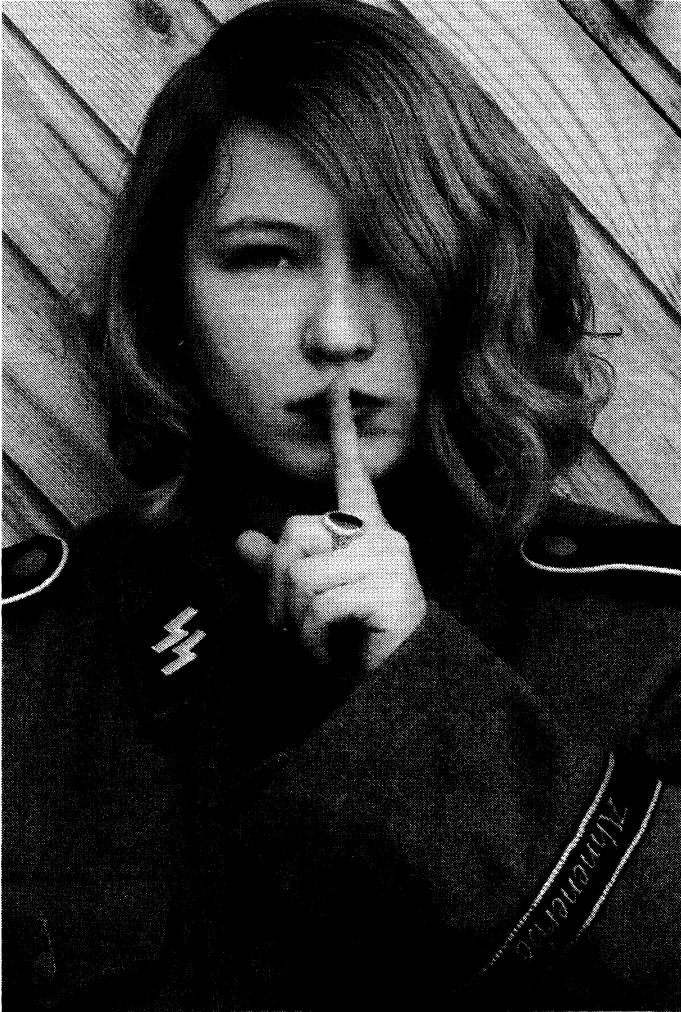

The Deutsches Ahnenerbe

It is hardly possible to speak of the esotericism of the Third Reich without mentioning the Ahnenerbe (legacy of our ancestors). The mission of the Ahnenerbe was the rediscovery of the ancient origins of the Aryan race and all which that statement implies. In such a momentous search we are immediately met again with Horbiger's 'World Ice Theory'. In other words, a cosmic catastrophe, in which, we Indo-Europeans are the remnant of a lost race and spirit. A divine race who possessed technologies that sound like science fiction when first encountered. The Ahnenerbe would search the entire world for the scattered pieces of a jigsaw puzzle that when reassembled reveals a stunning picture of a fabulous and forgotten history.

In 1927, the Dutch historian Hermann Wirth, who was enthralled by the legends of Thule and Atlantis and the origin of the Germanic peoples, founded the 'Hermann Wirth Society' for the purpose of expounding his conclusions from years of research and study. Wirth would also delve into the Nordic runes along with many other findings, such as, the Tuatha de Danaan. His research brought him to the conclusion that at one time all Aryans had an Ur-religion or original religion. He would publish the famous *Ura linda chronik* in 1933.

Richard Walther Darre, who had been a main force of the 'Blood and Soil' ideology, was the director of the 'Race and Settlement Office' (Rasse- und Siedlungshauptamt) or simply known as 'RUSHA'. His first book, *Das Bauerntum als Lebensquell der nordischen Rasse* (The peasantry as life-source of the Nordic Race), was written in 1928, in which, he advocated getting back to and being a living part of the land. As a naturalist and National Socialist, he was instrumental in the great support Hitler had from the 'simple farmer'. He was closely associated with the high circle of S.S. mystics, such as, the great Rune Master Karl Wiligut and the Holy Graal seeker Otto Rahn.

By 1935, Heinrich Himmler brought these men and their staffs together and officially became known as 'The Deutsches Ahnenerbe'. It is almost hard to fathom that the results of such an organization could be state sponsored. The Ahnenerbe would research every clue into the lost science of the 'ancient ones' and

simultaneously would always be on the quest for the superman or overman; a higher man of consciousness who would act conscientiously with that which was being rediscovered. We will never know the full extent of the divine wisdom the Ahnenerbe uncovered because they took it with them, but we do know that they left no stone unturned. The three main objectives of the Ahnenerbe were first to prove the existence and advanced technologies of the lost race and ancestors of the Aryans. Their second objective was to locate, at least, Hyperborea and Atlantis. Their third objective was to verify, through scientific evidence, the 'World Ice Theory'. All of these objectives are truly the same objective, which is actually the story being told in this book.

World renowned scientists, mystics and adventurers flocked to the ranks of the Ahnenerbe. They would have scores of institutes, departments, and staffs. One such member was the archeologist Edmund Kiss.

Kiss was one of the early explorers to shed light on the ancient Aryan origins of one of the most famous and mysterious ruins nestled high in the Andes Mountains known as Tiahuanaco. In 1937, he would publish *Das Sonnentor von Tihuanaku und Hörbigers Welteislehre* (The Sun of Tihuanaku and Horbiger's Cosmic Ice Theory). He would directly take on the 'academic world' in his assertion that the ruins had been built 17,000 years ago by Hyperboreans from Thule, which led to his ridicule by the 'establishment'. This was at a time when the 'intelligentsia' claimed Tiahuanaco to be only 2000 years old. Since then archeologists have admittedly recognized the ruins to be much older than they originally determined (wished), but no one has yet offered Herr Kiss an apology.

Another fine example of a visionary sponsored by the Ahnenerbe is Wilhelm Teudt. It was the highly religious Teudt who would be the spearhead in the excavations and study of the mysterious Externsteine, the great Holy site of pre-Christian Germany. Early on Teudt's 'Society of friends of German Pre-history' had already shown the astronomical significance of the mighty rock outcropping and coined it 'Germany's Stonehenge'.

By 1934, the S.S. took over control of the Externsteine and commissioned Teudt and the Professor Julius Andree for an in-depth study of the site. They confirmed that it was indeed an

astronomical observatory and believed that it was the location of the ancient Irminsul destroyed by the Emperor Charlemagne.

We cannot say exactly what all of their conclusions were because that is information which they kept for themselves – the S.S. never made public their findings. It most likely had to do with Teudt's contention that several 'Holy Lines', also known as ley lines, intersect at the sacred pillars of stone – a hub of earth and cosmic energies. Teudt had been conducting a serious investigation into the subtle streams of energies throughout Germany. He spoke extensively of his research in the 1929 release titled, *Germanische Heiligtümer* (Germanic Sanctuaries).



The Externsteine

Probably the most well known inquiry made by the Ahnenerbe was the expedition to Tibet. There has already been much written about the Tibet mission - more than we could ever add to, but we should try to set a couple of matters straight. Tibet is one of those subjects that have been severely abused by lesser men. As with practically every page of this work – a book could be written on it alone, but our job is to fit the pieces together.

The first matter we would like to set straight is the

disinformation campaign that claims that the famous scientific explorer and leader of the expedition, Ernst Schafer, had been opposed to any idea of a secret past of mythical proportions. This often spiteful and lesser understanding is easily disproved with the fact that Schafer idolized the pro National Socialist Swedish explorer Sven Hedin. Schafer even named his department after Hedin, 'the Sven Hedin Institute for Inner Asian Research'. It was Hedin who discovered the lost city of Loulan in the 'desert of death' in China and where archeologists still find the mummified remains of 'large' Indo-Europeans from a forgotten past. Hedin had claimed that the Tibet Lamas were the protectors of a 'secret knowledge'. It is hard to believe that Schafer could be such a cynic while his mentor was not.

The primary reasons behind the expedition were to determine whether the Tibetans were a remnant of the Aryan race and to search for the legendary kingdom of Shambhala of Tibetan tradition. In other words, to unravel the ancient mysteries and myths of the Tibet connection with the pre-history of the Aryan race and to make contact. The taking of cranial measurements and the making of facial casts of locals by the S.S. anthropologist Bruno Beger was physical evidence enough to prove that the Tibetans shared racial traits with the Aryans. Therefore, with that matter settled, the focus became the ancient past, which would include the mystical and hidden world of Shangri-la or Shambhala and the real concrete discoveries would come by way of the pre-Buddhist religion of the *Bon*.

In Tibetan tradition, the Bon religion traces back as far as 18,000 years ago. The Bon religion is so old that it synthesizes the Persian and Vedic traditions. The founder, Lord Tonpa Shenrab Miwoche has been identified with Mithras and his doctrine was the way of the Swastika. The nine Swastikas represent the 'Nine Ways of Bon' and the Swastika or Yungdrung is a symbol of permanence and indestructibility of the wisdom of Bon. As it is always with those things of God, Yungdrung Bon is eternal and without a beginning, but in our present cycle it originated in the land of Olmo Lung-ring where Tonpa Shenrab descended from the celestial Heavens and took up incarnation amongst men as an Aryan prince. The similarities between Shenrab and the later Aryan prince Siddhartha Gautama

(Buddha) are so striking that it appears to be another case of an attempt to reinstitute the older and more pure or original idea. All of this comes from Lord Vishnu, for He is every Avatar.

Olmo Lung-ring is Shambhala and the Dalai Lama himself will tell you that. We are quite fortunate to have access still to some of the ancient texts of the Bon, for in their description we have a reliable source. It is described as a lotus of eight-petals under a sky which appears like an eight-spoked wheel. In the center rises Mount Yungdrung Gutseg, the 'Pyramid of Nine Swastikas'. At the base of Mount Yungdrung Gutseg spring four rivers, flowing towards the four cardinal directions. To the south is Barpo Sogye palace, where Tonpa Shenrab was born. The mysterious land of Olmo Lung-ring, or Olmoling, is said to be to the northwest of Tibet in a land called 'Tazig' and encompasses one third of our earth. It is claimed that the ancient Bon texts describe how the mountain of nine Swastikas had to be moved from the North (Hyperborea) to its present location.

Olmo Lung-ring or Shambhala, an imperishable sacred land which is the spiritual center of the world, existed on earth from the very beginning of man. It was the place where the celestial gods of Light descended from heaven to earth in order to take up incarnation as men and ensoul the physical bodies which had been prepared for them. Since the time of the beginning, Olmo Lung-ring has been the sanctuary of wisdom and the receptacle of the highest mystical teachings being brought down from above. This mysterious land, at the center (Mount Meru), has been known by various names in ancient traditions throughout the world. And it is from here that the great purifier and last Avatar, Vishnu Kalki, will come from.

Thus, Olmo Lung-ring is not only an earthly paradise, but a hidden sanctuary of wisdom that holds the greatest of treasures—the Supreme Secret (Holy Graal). This is the precise knowledge of who we really are, whence we have come and where we go. It is the secret hidden in the heart of every man and the reason why every Buddha wears a Swastika on his heart.

One of the finest artifacts that the Ahnenerbe mission brought back to Germany was what has been called the 'Iron Man'. Beautifully crafted from a piece of the rare 'Chinga meteorite' substance, said to have fallen to earth in a rain of

'Final Battalion'

debris by a closely passing fiery comet (probably Venus), that was most likely the demise of the Clovis culture around 13,000 years ago. This meteorite 'Buddha' is clearly that of the 'first Buddha' and founder of the Bon religion, the Lord Tonpa Shenrab Miwoche, who is also known as the Germanic Wotan.



The Lords of the Black Stone

Much has already been written about the Thule Society. We do not wish to hash over the same old materials, but we would like to include a few essential factors to help make clear the reality of the situation of those who had first sponsored the Vrilerinnen.

Whatever his faults may have been, no one could deny Sebottendorff's ability to bring several impressive personalities under one roof, but it was the backing of the GermanenOrden that gave Thule form. The GermanenOrden had been labeled and banned as a modern Holy Vehm. Therefore, the Thule Society was the cover name given to the Munich branch of The GermanenOrden. Men such as Alfred Rosenberg and Rudolf Hess were members. Thule created a labor party for the worker. This organization would later become known as the 'National Socialists German Workers Party'.

The GermanenOrden was created by the inner circle of Armanen Rune Master Guido von List. These were the men who turned wisdom and ritual into action. The list of members who made up the core of the German Order is quite notable. Theodor Fritsch, who had been named the 'Past Master of the movement' was second only to the later Adolf Hitler in popularity. His books were classroom reading during the Third Reich. The dreaded Philipp Stauff, the Folkish writer and famous exposé of crypto-jews. Lorenz Mesch, who was instrumental at putting the Secret Tribunal back on the map. The ancient 'Coat of Arms' researcher, Bernhard Keorner and the martyr Walther Nauhaus – the man who coined the name 'Thule Society' – were all members of the GermanenOrden. The main body was centered in Berlin, but in Munich, as previously mentioned, they became the Thule Society.

It was the Thule Society who overthrew the communist takeover of Bavaria. Thule bled for Germany. Thule's final 'putsch' was the transfer of their combined energy and power into the esoteric Order of the S.S.

The S.S. were inspired by the Teutonic Knights but there is also a strong connection to the Templars. There is no mistaking the correlation in the S.S. Deaths Head. Truth be known, all

chivalric orders throughout time are connected by the same spirit of honor. They all serve the Graal mythos and are proven in the Hyperborean memory and ideal of chivalry, but our present focus must be on the Knights Templar alone.

The Templars are one of those subjects that good men shall never agree upon. We are apt to think that it is a bit of both good and bad. Their common origin with the likes of the 'Priory of Sion' (Elders of Zion) cannot be denied. Their 'King of the World' agenda was in cooperation with Jews. From that conspiracy rises the treason to this very day; Golden Dawn, O.T.O., Freemasons, etc. Honestly, the corruption that transpired in France and fiascos such as the Magna Carta, no Knight of good conscious would suffer such intrigue, therefore, he removed himself.

There were Honorable Templars with a Divine mission who embraced the Holy Truth and became something else. The chivalrous Knight shunned the likes of the atrocious French revolution 'supposedly' committed in their name. The Graal Knight had no part in the 'Zion' conspiracy. For instance, the Templars in Germany, at the time of their demise, were severely tortured and yet there was not one confession made.

Many of these German Templars would later join the Teutonic Knights. The Teutonic Knights had an advantage, they had Wotan. They served the pure Spirit of the AllFather through their ancestral blood memory and the little known secret of their Patroness Mary, for He is the Power behind both.

"Truth is neither the Cathars nor the Templars followed the path of the Vira; they were not Aesir in a warrior combat against the Demiurge. They had forgotten the Runes and their Hyperborean origin, remembering nothing about Wotan...they were ignorant of the importance of the purity of luminous blood as the only means to maintain the Memory of the Polar origin of the spiritual Aryan race. They were hypnotized and destroyed at the moment that they began to awake from their hypnosis." - Miguel Serrano

We see the true Teutonic Spirit of the Templar persevere in Lanz von Liebenfels 'Order of the New Templars'. One should ask themselves; where did von Liebenfels acquire the profound

information he presented in his publication 'Ostara' or the all but forgotten history of man he presents in *Theozoology*? The answer is to be found in 'Die Herren vom Schwarzen Stein'.

'Die Herren vom Schwarzen Stein' or Lords (Noble Men) of the Black Stone is a fascinating story. The legend begins with a sect of German Templars who, upon returning from the crusades, made their home and Shrine to 'Isais' on the magical Untersberg Mountain in the Bavarian Alps.

Untersberg is legendary. The bottom has never been found in its elaborate cave system. This is where the great Barbarossa and his loyal Knights await the day of reckoning. Another version claims it to be Charlemagne. We find the same legend with Arthur in Avalon. The story is the same, the great King who is not dead, but only sleeps until the day of the new Dawn, the day of His awakening and triumph.

If we recall that fateful meeting when the 'Prelate Gernot' gave audience to the 'Vril', it now comes all together. All the pieces begin to fit too wisely for any charlatan to muster. There is a divine hand, in this, who is assembling His parts. Gernot was the prelate of the 'Societas Templi Marcioni'.

It is important to know who the Marcionites were. Marcion was a Gnostic Bishop from the first century who proclaimed what many learned men have taught. Marcion proclaimed the tribal Jewish God of the old testament is, in all actuality, the dark Lord who has his job to do and that Christ was of the True Creative God of the Spirit, who came with His light into this world of mass and shadow to save the Divine Souls who are now trapped here in the material world of the Demiurge. The Knights came into contact with this ancient doctrine during the crusades. Prelate Gernot represented the ancient order of those Templars. Van Helsing relates more of that 'first meeting':

"The main part of the discussions dealt with the background of a section of the New Testament, Matthew 21:34. For there Jesus addresses the Jews: 'Therefore I tell you that the kingdom of God will be taken away from you and given to a people who will produce its fruit.' The complete original text that is kept in the archives of the 'Societas Templi Marcioni' says it even more clearly. But the point is, in that text Jesus actually names the

'people', He talks to Teutons serving in the Roman legion and He tells them that it is their people that He had chosen. That is what Sebottendorf and his friends wanted to know for sure: That the Teutonic or German people were commissioned to form the realm of light upon Earth - in the 'Land of the Midnight Mountain' (Germany). The place where the ray would meet the Earth was given as the Untersberg. Gemot told them about the advent of a new age - the changeover from the Age of Pisces to the Age of Aquarius. The time of changeover from the old to the new age in Mesopotamian teachings is called the three 'double steps of Marduk', of 168 years duration, at the mid-point of which the ILU ray, the Divine Ray, is expected to reach Earth."

For those who are aware of the 'eastern connection' this all begins to make sense. Sebottendorff had been earlier initiated by a sect of Sufism. The 'Mohammedan' Sufis were the guardians of an ancient secret that has its outward sign in Mecca in the form of the black stone of Kaaba. Most are aware of the highly venerated 'meteorite' that Muslims adore to this day, but few know of its origin.

Mohammed belonged to a tribe named the Koreishites and they had for their Patroness the ancient Aryan Goddess Al Uzza, also known as Uzza or Izza. Izza is associated with the Morning Star and named the 'Mistress of Heaven' and the 'Mighty One'. She has been identified with Venus, Athena, Isis, and the counterpart of Lord Shiva (it was the Vedic Aryans, from whence the story had its source). She is the Eternal Feminine once known as Al Jauza, which is, an ancient name for the constellation of Orion. Close to Orion is Taurus and the star Aldeberan, from which, the long journey was said to have started so long ago (in the last chapter we shall address the deeper meanings of all this).

Only later was She reinvented as Al Uzza the Morning Star and once again took the form of the young maiden. And like so many other instances in history, the Arabs loved Her so much that now She is thought of as the daughter of Allah (this same theme we also find in the lady Fatima, daughter of the Prophet). The Prophet told his followers that in 'the Black Stone' resided what once was an Angel or that which came from Heaven and

had properties 'beyond this world'. With legends such as these it is easy to see how the Graal became a stone, a Black Stone, which is, the Black Sun and also clear to see that Izza is Isais.

The sect of German Knights who would become 'Die Herren vom Schwarzen Stein' had been given a prophecy by 'Isais'. A vision of Her was described by the Templars Roderich and Emmerant. 'Isais' appeared as a young Maiden obviously not of this world; auburn hair that reached down to the ground, held back by a golden head band. Her appearance was that of light, ultra fine gold, and glistening green, a dress made of golden leaves. Her Divine face of beauty was thin and fair with shining amber eyes. Her goodness and beauty were mesmerizing.



Isais

‘Isais’ is a name of mystery to most. Today in English they call her Jesse. Some researchers, such as Wotans Krieger, have shown the Goddesses Isais, Isa, Zisa (associated with the ancient Teutonic SkyFather Tiu or Tyr), Cisa, Isis as being one and the same. Bulwer-Lytton simply called Her Zee. We could include Isolde, Isabella, Cecilia and Caesar. Interesting that Arabs, the children of Esau, identify the word Isa as Esu, Jesus.

Our interests lie in Her German identity. We find this in the Greek Eos, Goddess of the Dawn. She is Eostre, The rising sun in the East (Easter). ‘Isais’ is Ostara! Teutonic Goddess of spring. The young, evergreen maiden of fertility, resurrection and Dawn. Patroness of Lanz von Liebenfels Order of the New Templars. The North men named Her Idunn. She is the Goddess of eternal youth, which is, vril, vitality, health. It is ‘She who waits by a fountain’ in a garden of golden apples. The luminous emissary of the AllFather and embodiment of the Sig Rune.

It is said She gave the Knights a ‘stone’ and Her mirror. The mirror is actually part of the Stone. This is also the ‘mirror of the Princess Papan’. We will follow the trail of De Mahieu, Master Serrano and the North men of Paraguay a little later. As of now, our story must remain in Bavaria, for that is where, almost 800 years ago, Ostara had given a message for the Hero’s of men – also known as ‘Die Isais Offenbarung’.

The messages are long and difficult to translate into one flowing idea. Plus, we know that there has been disinformation added and that the Hitler Loyalists took the best part with them. That being said, we wish to give a genuine interpretation of Her message. A message we understand well because we knew it long before we ever read it. It is the Truth that dwells within us, a Minne (love memory), a Blood Memory. Isais tells us:

The AllFather is the Light and Maker of all things visible and invisible and everything that is of Light is of Him. Eons ago, all dwelled in the bliss of the AllFathers Light. Then came the treacherous one, who far away from the realm and light of AllFather created hell and all the pains and illusions that go with it. Many children of the Light, not knowing in their innocence, were lured away from the Light and fell so far into the shadow of mass and delusion that they forgot who they were. Great eternal

spirits of Light so enthralled by the distraction that they lost their way back home, for there was a great, endless void between Heaven and Hell.

AllFather, in His mercy, made for them the earth (Midgard) and filled it with His Spirit and blessings, so as to be a bridge between Heaven and Hell. And in this way the lost spirits may come to realize who they were again and have a door for returning. AllFather sent other children of the Light (the Gods) to help their lost brothers and sisters find their way back home. They built Asgard and have been battling the forces of shadow and illusion ever since. Ever the war raged here at earth on our behalf, but then something went terribly wrong. Betrayal! What had been a rescue mission now became a struggle for our very own immortal souls:

***“Slaughtered was the All-Father’s light as a living example
By the followers of the dark horror.
For All-Father himself had been as All-Christ.
The darkness hatred raged against Him.
Martyred was the light and power, trampled was truth,
the liberator bound.
- A terrible time.”***

Enter Ostara of the Dawn, the brave maiden who once saved the ‘Black Stone’ from the Lord of shadow and his Hell, where he feasted on the bone marrow of men, thus, becoming a prisoner of his own illusion. It is a grand tale which is reminiscent of the many legends of Heroes retrieving the Graal from the Underworld, but also reminds one of such stories as the kidnapping of Persephone and Idunn. With the help of the ‘Strong One of Heaven’ who rescued Her, She made it back to Asgard with the Stone. But the horrid experience ever changed Her. In Her loneliness, AllFather came in the guise of an Eagle and comforted Her by revealing that all was for good reason. He had the intention of giving Her to a Noble Race who were in need of Her aid. AllFather put in Ostara’s heart a great love and devotion for the Germanic peoples of the world. She promised never to leave us and will be our help until the very end. She said that although we may not see Her, She is always at our side. She

is the Valkyrie. She is our Lady who has done everything for us, better than we have deserved, for Her love of us is perpetual.

She is always searching for the bravest of men and promises that the greatest of Heroes remain with Her. Truly, every act of Chivalry is done in honor of Her and She instructs us in the ways of Chivalry by Her very example. Isa prefers to come as a sister to the Noble Soul but to the wrongdoer She is the black panther. Truly, She is Urda and comes at us with exactly what we are. For example, at Fatima, She was the ever spotless Virgin when appearing to the innocent children. To the proven Knights She appeared as the ever young Brave Maiden.

She revealed Herself to those Knights, who would become 'The Lords of the Black Stone', long ago with the instruction to persevere and keep safe the 'Black Stone', for without the Power of the Stone the earth would surely fall to the dark Lord. She then gave them a promise, the promise that as the Age of Aquarius drew near She would erect a great Pillar of Light for the world to see as an example of the peace to come. The Pillar of Light was none other than Adolf Hitler. This is what the wise members of groups, such as the Thule Society, had been preparing for and waiting upon in earnest; the Messenger of Light. Not only did She give that promise, but also much sound advice throughout Her visions.

We would like to share some of those with the reader:

- Always be of hope, for hope attracts the Power of God
- Be of good cheer with thy own, love at home and have compassion for the misfortunate, but when met with evil do not hesitate:

"Knoweth the place, which is yours.

He who hesitates and tolerates - tolerates the powers of hell to prevail.

Offer gentle greeting to the meek, but hurl battle cry against the evil one.

Know love at her place and know the hour of the spear."

- Do not mingle the blood with foreign nations, keep thy blood as pure as possible.

- Be faithful to ones work and duty for it brings joy and replenishes with new force (Vril).
- The Aryan has a great friend in the 'Bull of Heaven', but only call on Him in the greatest of need and then only through Her, for He can be terrible and has no patience for the follies of men.
- Voices call from the other side, but beware for much is deceit.
- Do not try to change the nature of a person. There are many kinds on this earth; there are the lost souls of the children of Light, there are those who are here to help and there are many other creatures. Some are Heroes, others Saints, and many are Devils, only the AllFather knows what is the part and best for each one. At this point in time only the animals and plants are still innocent.

Ostara is a ray of hope, fortunate we are to have Her. She has had so many names, but always trying to help us help ourselves. Lucky is the man who can call Her friend and even luckier is the Hero who sees in Her his Beloved. She has suffered so much for us and it is high time to return the favor. Let there be an alter for Her high on every mountain, an alter that begins in our heart.

There is a section in Her revelations that we feel are too pertinent to the future for us to give our modest interpretation alone. Therefore, here follows a translation of those few verses for the sake of the one still to come:

"The Truth I speak

And will further show you what is plaguing the earth

- Schaddain haunting the world villages and countries, oceans and canyons, wastelands and forests, meadows and mountains.

***He brings the sources of torment,
permeates the history of nations with blood,
behaving as if he himself were God.***

***Many faced is the grimace of the evil one,
which spills everywhere from the joints of the earth,***

Many headed it tears at throats.

No stroke of the sword alone is capable of splitting all.

***Oceans of flame will roar against the lands
in the fullness of time, before the worm goes by.***

*Malice nourishes the troublemakers belly,
makes powerful the thrower of the shadows.
Who will command the horror to stop, while waiting for
Aquarius to pour clear waters?*

Therefore persevere!

*You shall stay prepared through all times
until the hour of victorious swords is fulfilled.
The flags will fly high in the victorious final battle
when Aquarius saturates the earth world.*

Still far away is the hour of victory.

*Sweeping clouds tower here - to spew lightning.
Kingdom of Light, O realm of Light, the ship breaks the keel,
Debris only landed on this beach. Study the pieces,
carefully watching for a new action:*

Victory ship once more.

If the ray blows the sails

*- from the other side he comes by Ilu's hidden sun
- then is the time.*

*In investigating the starry world,
look to the head of the bull. He brings the lance.*

Weigh out of the stars measure:

*From the head of Taurus to Aquarius.
Unter the center hides the Black Stone."*

It would seem as if Ostara was speaking of a 'central sun' and 'royal stars', which play a significant role in past and coming events, with every emphasis upon 'the Man' pouring forth his cup of vivid (light) waters upon us. We do not wish to speculate any further, but do offer the following illustrations from an interesting book by George Hunt Williamson, *Other Tongues – Other Flesh*.

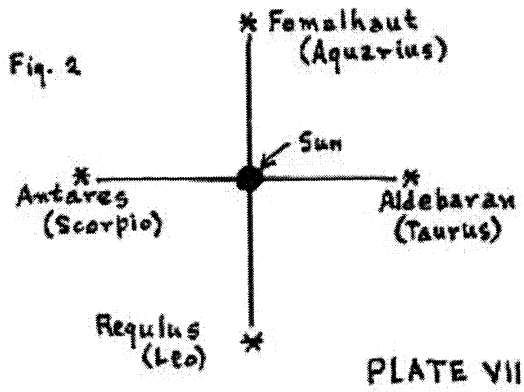
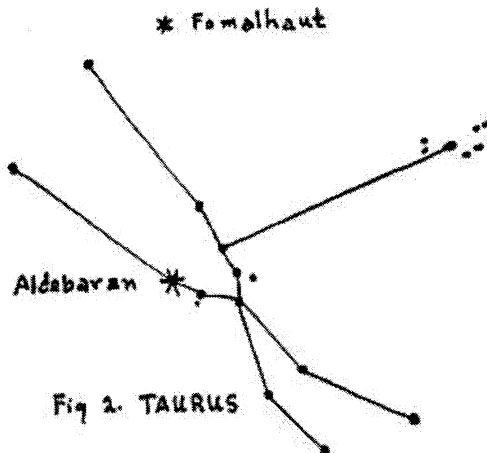
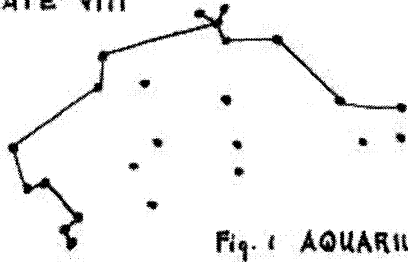

PLATE VIII



The children of mammon, as should be expected, are quick to dismiss the prophecy, but its Truth is evident in how it all comes together. Only the Divine Hand can work out such fabulous conclusions.

For instance, the Untersberg Mountain (Woden Mountain) is located near Berchtesgaden (a Thule Society stronghold and the Fuhrer's 'Eagle Nest'), but also Augsburg. It is said that Augsburg is the oldest city in Germany. Augsburg was founded by the Suebi, Semnone, Armanen. The Suebi territories that remained are now called 'Swabia'. Originally named Zizarim, the town has always been under the special patronage of Zisa.

Zisa, as mentioned, is the counterpart of the great Tiu – Ruler of the *Thing*. The Ancestors of Augsburg even recognized in Her the name of *Zistag* (Tuesday) and credited Her for a great victory over the Romans. Her Power was so great with the AllFather that she could literally undo one's Orlog, that is, if the cause was just, and only the Norn has the Power to do that.

With the arrival of Christianity She became known as 'Our Lady, undoer of knots', who has the power to undo immovable obstacles. She is still highly venerated in the city of Augsburg under this quickly becoming famous title. What a miraculous name to invoke Her by.

As previously said, She does more for us than we deserve, and we may thank the AllFather for that because He is the Power behind Her. She is the Lady of Victory, Our Lady Sig, Sister to the Noble Race and the Beloved of the Hero. And when all else seems lost, Isa with Her heart of gold is still there.

She who will never leave us, promised that Hitler's Germany would be a shining example for a time still to come. A time not yet here, but by faithfully continuing the struggle under His banner, that new dawn would come. We must fight and suffer for our convictions, otherwise, what did we achieve? A day of 'Victory' laid out in the starry Heavens, if only we choose to earn it, in a word - Destiny.

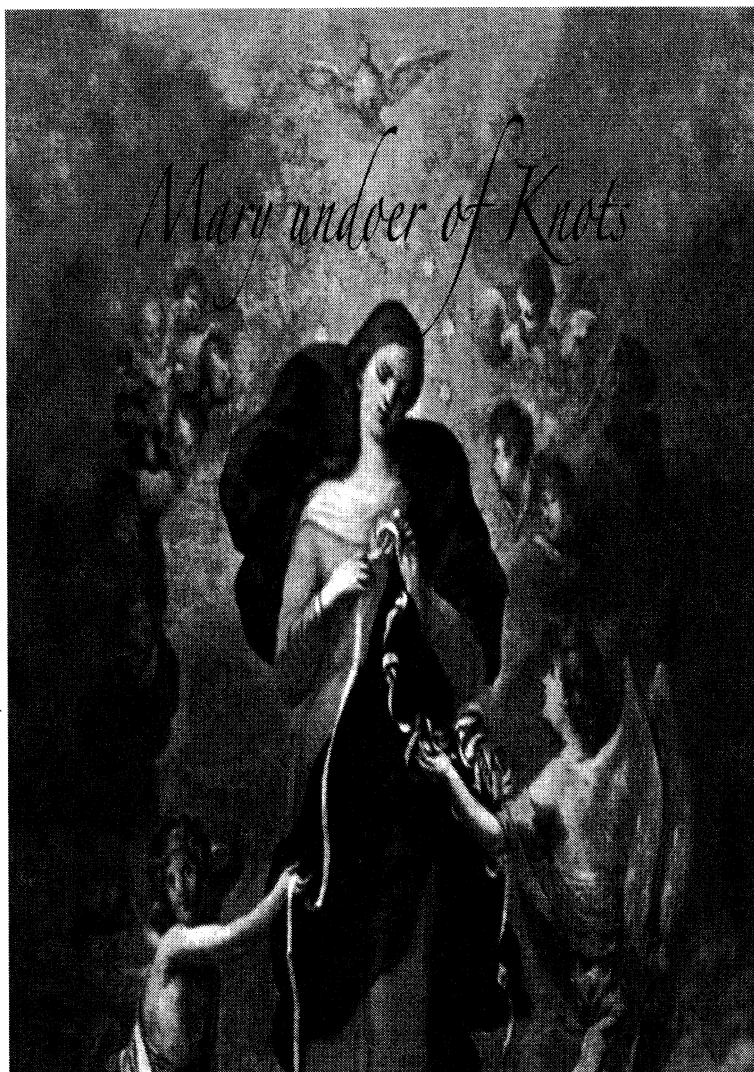

Patroness of the ancient city of Augsburg, Germany

'The War Goes On'

Antarctica

There is so much to take into account when dealing with post-war Hitler loyalists. We shall make an effort to present it in sequence. A fact that few people are aware of is that Germany has never had an actual 'Peace Treaty'. Germany has been an occupied nation since 1945. Although this may seem trivial, it is not when we consider what this really means. It means that 'The Final Battalion' is the legitimate Germany. Our beginning would have to be the Third Reich's conquest of Antarctica.

The newly founded 'German Society of Polar Research' first explored the Antarctic in the early 1870's. By 1911 they were measuring the earth's magnetic field from somewhere near the South Pole. With Hitler's rise to power, groups like, the 'German Society of Polar Research' found friendly backing.

It was Captain Alfred Ritscher who led the 'official' Deutsche Antarktische Expedition. For the mission, Ritscher was given the Schwabenland; a German aircraft carrier that actually catapulted the Dornier Super Wal flight boats into the air. At the end of each flight a crane on the ship lifted the aircraft back on board after they had landed in the water.

The Germans would document and lay rightful claim to an immense area. They would name it Neu Schwabenland and announce areas free of ice, such as the well-known Schirmacher oasis. It was at this time that they announced the discovery of a new mountain range. Mountains have caves. The stories of a network of ancient tunnels, a geothermal lake that could only be reached through several miles of cavernous tunnels, etc. have their location in this 800 mile long mountain range. The Germans named them Muhlig Hofmann. All of this was done under the guise of mapping and whaling. 'Official' reports ceased to be in existence with the start of the Great War. The reconnaissance of the Antarctic became a U-boat mission.

At this point the tales do become fabulous, Max Peck, in his book *Children of the Universe* states:

“After all the data was gathered, i.e. possible location of alien craft found, deep underground, construction teams came pouring into the renamed ‘Neuschwabenland’, today New Swabia, in an area of the Antarctic between 20 degrees East and 10 degrees West in Queen.”

Peck goes on to claim that the S.S. indeed found an ancient technology (saucer) which was relocated back to ‘Wenceslas mine’. Simply fabulous. He is not alone. A fellow by the name of Wes Penre tells us:

“We discussed how a Nazi expedition in 1939 found the ILAT-LITUM plates/tablets in Antarctica. Now, as we are approaching 2012, Thule doesn’t mind that this information comes out in the open for those who have ears to hear and eyes to see. A Thule member sent me something they call ‘Genesis’, it is the German translation of ILAT-LITUM, translated into German by Tibetan monks during Nazi Germany.”

We have looked at the ILAT-LITUM plates ‘supposedly’ found by the Germans in the 1938-39 expedition. It is more of the ‘Sumerian’ accounts of pre-history and promised return. The ‘plates’ go on to claim that Lemuria was a land of ‘reptilians’. Funny how those ancient statues on Easter (Ostara) island look anything but ‘reptilian’. It is too muddled for us to present in this honest book. It is part of the endless stream of disinformation and is probably even dangerous.

The other extreme is just as bad. The dry rationalists who try to debunk everything they do not see. The first casualty in their argument is always common sense. *Hitler’s Antarctic Base: the myth and the reality* by Summerhayes and Beeching is a well written pro-British booklet, but as narrow-minded in its approach as any conspiracy theorist. In it they acknowledge:

“The Germans did intend to build a base in Dronning Maud land. There were secret British bases in Antarctica during WWII. Operation Highjump was primarily a military exercise whose results were initially classified and hidden from public view.

Three secret nuclear explosions did take place in the general region in 1958.”

After their initial admission, they literally spend the rest of their work trying to disprove any information that cannot be found in a ‘written report’. The problem with this of course is that time and again they bypass the obvious. For instance:

“Apart from Wermuth having destroyed his ships papers and military equipment, the only unusual thing about U-530 was it seemed to carry more cigarettes than may have been expected.”

Next comes an in depth review of the cigarettes. Leaving forever behind the most important statement of all – *‘having destroyed his ships papers and military equipment’*. Therefore, none of us shall ever know, beyond a doubt, what the true mission or capabilities of that submarine was. Alas, these are the same ones who would teach that our consciousness evolved from an ape. With the layers of disinformation thicker than any sheet of ice that covers the Antarctic, we must once again turn to the man whom we can trust, for he knew not how to lie:

“Captain Ritscher had discovered the warm water oasis in Antarctica and the network of tunnels beneath the Weddell Sea, and the submarines of Admiral Donitz found the hidden passage between the Poles that communicate with the Hollow Earth, inner. Adolf Hitler began to organize his plan, building his ultimate refuge, in this impregnable terrestrial paradise, to reach out to the most pure of the Aryan race. Young men of twenty years were found commanding U boats, lost for months on the ocean, and who weighed anchor in Mar del Plata. They formed part of a submarine caravan whose ultimate direction was unknown, since they had lost the course set by the guide-sailor.”

- Master Serrano

There we have it coming from the High Priest of Esoteric Hitlerism. The tales are endless of a top secret underground facility. The reoccurring theme is that this ‘New Berlin’ is where

the greatest technological advancements were spirited off to. There is no denying that they had to have gone somewhere.

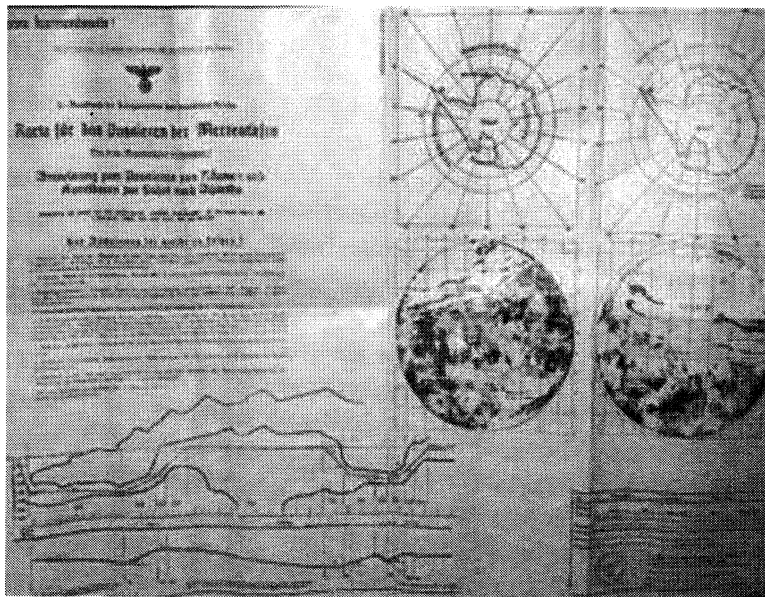

1944 German map with coordinates of the inner earth

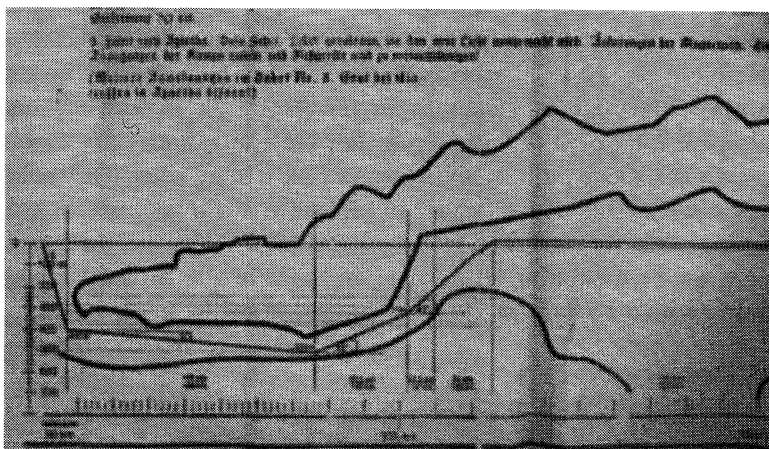

Close up of Passage way

'Final Battalion'

Here follows a translation of the directions detailed on the 1944 map:

Decent at the point with the coordinates: Exact Intersection: 64° southern latitude and 1° eastern longitude, to a depth of 400 meter.

The instructions have to be strictly followed!

1. Decent, from the point of decent with half speed, a starboard declination of 10° with a bow-heaviness declination angle of 5°. Distance 188 sm. Given depth - 500 meter. (Because of the moving inside the corridor the pressure on the ship body when maneuvering is insignificant)
2. Ascent, Full load with a stern trim, Ascent angle 23° with a port declination of 22°. 190 meter upwards. Distance 755 sm.
3. Difficult maneuver! Ascent full speed with a stern trim, Ascent angle 41°. Proceed straight ahead. 110 meter upwards, distance 215 sm. Afterwards starboard declination of 8° until ascent to the surface in a distance of 81sm.
4. Proceed on the surface within the grotto with a starboard declination of 8°, Distance 286 sm
5. 6. Schwieriges maneuver! Descent. With a bow-heaviness declination 45° to a depth of 240 meter, Distance 60 sm. Afterwards with a port declination of 20°, at which the descent to 310 meter to the entrance to the corridor continues. After the 310 meter mark the bow heavy descent need to be continued. Descent angle 7° until 360 meter, distance 70 sm. Further starboard declination of 31° to a depth of 380 meter.
7. Descent, Bow heavy, ascent angle 22°, 100 meter upwards with a port declination of 26°. Distance 43 sm.
8. Ascent, Stern trim, Ascent angle 45°, straight ahead until reaching the surface of Agartha. Distance 70 sm.
9. Proceed to Agartha. Full Speed. Proceed straight ahead, until the new light can be seen. Change of magnetic poles. The changes of the compass needle and instruments are to be disregarded.

(Further instructions in package Nr. 3 only when arrived in Agartha to be opened)

A Russian has recently released a video (Hidden Antarctica) showcasing the 1944 German map and other S.S. papers that do display the seal of the Ahnenerbe. He claims their origin is that of de-classified FSB and KGB documents. In his defense, the Federal Security Service of the Russian Federation (FSB), and the head of the FSB's Registers and Archives Department, Vasily Khristoforov, have, as of late, made available a slew of classified information to the public. The recently released documents have caused quite a stir in several departments.

Incidentally, the map gives coordinates for descent precisely at the mouth of the very place Serrano claims - the Weddell Sea.

The Post-War

There have been many stories about military offensives after the 'end of the war'. The British author James Robert had interviewed surviving members of Operation Tabarin. Tabarin was a verifiable clandestine operation towards the end of WWII. One must ask – what was a top secret British military operation doing in the Antarctica? An explanation, such as, looking for a foothold in the Southern end of the world at that time is not adequate. Robert gives a fantastic account of a soldier's story in *Britain's Secret War in Antarctica*:

“We were informed that we were to investigate ‘anomalous’ activities around the Mühlig-Hoffmann Mountains from the British base in Maudheim. Antarctica, so we were told, was ‘Britain’s secret war’. We were then briefed on British activities in the South Pole during the war. We sat intrigued as to what was being divulged; none of us had heard anything so fascinating or frightening. It was not common knowledge that the Nazis had been to Antarctica in 1938 and 1939, and even less known was the fact that Britain began to set up secret bases around Antarctica in response. The one we were to visit, Maudheim, was the biggest and most important as well as the most clandestine Antarctic base of them all. The reason for its importance was the fact that it was within 200 miles of where the Nazis had supposedly built their Antarctic base.”

The tale goes on to tell of a commando operation to seek and destroy an underground National Socialist base. In the process they spy U-boat docks, disc craft, a mysterious energy source and so on. The account becomes outlandish by the time they are spotted ‘after’ placing hidden explosives to bring down the base and tunnel leading in and out. If there is any truth to this story it would be more likely that the SAS collapsed the opening of the tunnel and called it a day. This operation was suppose to have occurred in the first winter after the War.

The more verifiable and documented ‘Operation Highjump’ is an altogether different story. The famous Polar explorer Admiral Richard Byrd led the largest military mission to the

55 Club

Antarctic ever recorded. Byrd commanded at least 13 ships, 30 aircrafts and almost 5,000 troops. These numbers cannot be fully appreciated until it is compared to other military engagements. Participating ships included: USS Mount Olympus, the flagship; attack cargo ships USS Yancey and USS Merrick; submarine USS Sennet; Navy icebreaker USS Burton Island and Coast Guard icebreaker USCGC Northwind; seaplane tenders USS Currituck and USS Pine Island; destroyers USS Henderson and USS Brownson; oilers USS Cacapon and USS Canisteo; and aircraft carrier USS Philippine Sea. Aircrafts included PBM Mariner seaplanes, R4D Skytrains equipped with a unique wheel/ski combination, and HOS, HO3S and HNS Hoverfly helicopters.

It cannot be expressed strongly enough that this was a military operation. A critic's only defense is to claim that they were preparing for the Soviet Union. That may be more believable if we hadn't just finished creating the Soviet Union by giving them half of Europe. The 'cold war' was only smoke and mirrors. No, this fleet was sent to Antarctica for someone else. Someone the United States government deemed a real threat. Let us look at what the authorities do not say, for that is where the truth lies.

The area of the Muhlig Hofman Mountain range is noticeably absent from any 'exploration' reported by Operation Highjump. What also is absent is a sufficient explanation as to why they suffered casualties or why Operation Highjump hightailed it out of the Antarctic. The debunker claims Byrd was too far away from the Muhlig Hofman Mountains. But a rattled Byrd gave an interview to the journalist Lee Van Atta which was printed in the Chilean newspaper 'El Mercurio'. In it Byrd makes outrageous statements about an aircraft (or aircrafts) reaching the United States from the Poles. The disbelievers say that he is referring to the Russians again...So which is it? Did Byrd test aircraft that could fly to the States? Or were the Muhlig Hofman Mountains too far away? It can't be both you *damned* professional liars. Here is that interview from March 5, 1947:

“Admiral Richard E. Byrd said today that it is imperative for the United States of America to initiate defensive measures against

'Final Battalion'

the possibility of an invasion of the country by hostile aircraft from the polar regions. The admiral said he does not want to scare anyone, but it is a bitter truth that in the case of a new war, the United States could be attacked by aircraft that can fly from one or both poles. This statement was made as part of a summary of his polar experience, in an exclusive interview with International News Service. Referring to the recently completed expedition, Byrd said that the most important result of his observations and discoveries is the potential effect they have with regard to the security of the United States. The fantastic rate to which the world is shrinking - the admiral recalled - is one of the most important lessons learned in his recent Antarctic exploration. I warn my compatriots that finished are those times that we could take refuge in our isolation and rely on the certainty that the distances, the oceans, and the poles were a guarantee of safety.”

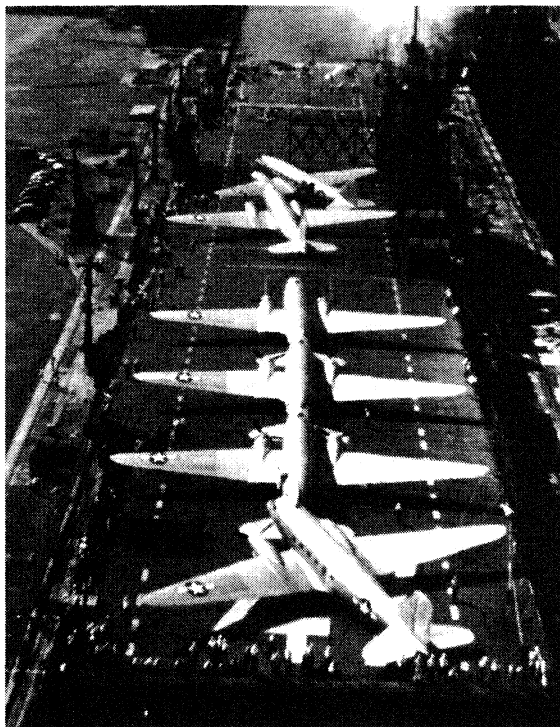

Operation Highjump - aboard the aircraft carrier USS Philippine Sea.

The Secret Diary of Admiral Byrd

The 'Hollow Earth Society' of Missouri, which was led by Captain Tawani Wakawa Shoush, seems to have been the first to put forth the *Secret Diary of Admiral Byrd* back in the 1970's. The 'Hollow Earth Society' had plans to make a trip to the inner earth via the North Pole. By all appearance, they appear to be genuine enough. The diary, on the other hand, isn't.

It is true that Admiral Byrd, working for Rockefeller and later the government, had been on several secret Polar expeditions, but here comes the major problem for the diary. The diary is allegedly from an Arctic (North Pole) flight dated February 19, 1947. We know he was with 'Operation Highjump' in Antarctica at that time. It is hard to believe that Byrd could get that mixed up in his journal. There are several other factors that do not add up. For instance, February would be the worst time for an Arctic flight; the logistics cannot be correct.

Nevertheless, the diary has quite the following. This is because of certain truths it pertains. Byrd did know about the 'Land beyond the Poles' and at the very least tried to locate that other world. Many of the details are too accurate to be ignored. We are of the opinion that the diary is a faulty version of a plagiarized event. That does not make the whole of its contents untrue. We present it in its entirety for the above stated reason, but also for another, which is, this short diary is in such demand that it can cost more than this book to purchase. It truly does have something to offer when you read between the lines:

"I must write this diary in secrecy and obscurity. It concerns my Arctic flight of the nineteenth day of February in the year of Nineteen and Forty Seven.

There comes a time when the rationality of men must fade into insignificance and one must accept the inevitability of the Truth! I am not at liberty to disclose the following documentation at this writing ...perhaps it shall never see the light of public scrutiny, but I must do my duty and record here for all to read one day. In a world of greed and exploitation of certain of mankind can no longer suppress that which is truth.

FLIGHT LOG: BASE CAMP ARCTIC, 2/19/1947

'Final Battalion'

0600 Hours- All preparations are complete for our flight northward and we are airborne with full fuel tanks at 0610 Hours.

0620 Hours- fuel mixture on starboard engine seems too rich, adjustment made and Pratt Whittneys are running smoothly.

0730 Hours- Radio Check with base camp. All is well and radio reception is normal.

0740 Hours- Note slight oil leak in starboard engine, oil pressure indicator seems normal, however.

0800 Hours- Slight turbulence noted from easterly direction at altitude of 2321 feet, correction to 1700 feet, no further turbulence, but tail wind increases, slight adjustment in throttle controls, aircraft performing very well now.

0815 Hours- Radio Check with base camp, situation normal.

0830 Hours- Turbulence encountered again, increase altitude to 2900 feet, smooth flight conditions again.

0910 Hours- Vast Ice and snow below, note coloration of yellowish nature, and disperse in a linear pattern. Altering course for a better examination of this color pattern below, note reddish or purple color also. Circle this area two full turns and return to assigned compass heading. Position check made again to base camp, and relay information concerning colorations in the Ice and snow below.

0910 Hours- Both Magnetic and Gyro compasses beginning to gyrate and wobble, we are unable to hold our heading by instrumentation. Take bearing with Sun compass, yet all seems well. The controls are seemingly slow to respond and have sluggish quality, but there is no indication of Icing!

0915 Hours- In the distance is what appears to be mountains.

0949 Hours- 29 minutes elapsed flight time from the first sighting of the mountains, it is no illusion. They are mountains and consisting of a small range that I have never seen before!

0955 Hours- Altitude change to 2950 feet, encountering strong turbulence again.

1000 Hours- We are crossing over the small mountain range and still proceeding northward as best as can be ascertained. Beyond the mountain range is what appears to be a valley with a small river or stream running through the center portion. There should be no green valley below! Something is definitely wrong and abnormal here! We should be over Ice and Snow! To the

portside are great forests growing on the mountain slopes. Our navigation Instruments are still spinning, the gyroscope is oscillating back and forth!

1005 Hours- I alter altitude to 1400 feet and execute a sharp left turn to better examine the valley below. It is green with either moss or a type of tight knit grass. The Light here seems different. I cannot see the Sun anymore. We make another left turn and we spot what seems to be a large animal of some kind below us. It appears to be an elephant! NO!!! It looks more like a mammoth! This is incredible! Yet, there it is! Decrease altitude to 1000 feet and take binoculars to better examine the animal. It is confirmed - it is definitely a mammoth-like animal! Report this to base camp.

1030 Hours- Encountering more rolling green hills now. The external temperature indicator reads 74 degrees Fahrenheit! Continuing on our heading now. Navigation instruments seem normal now. I am puzzled over their actions. Attempt to contact base camp. Radio is not functioning!

1130 Hours- Countryside below is more level and normal (if I may use that word). Ahead we spot what seems to be a city!!!! This is impossible! Aircraft seems light and oddly buoyant. The controls refuse to respond!! My GOD!!! Off our port and star board wings are a strange type of aircraft. They are closing rapidly alongside! They are disc-shaped and have a radiant quality to them. They are close enough now to see the markings on them. It is a type of Swastika!!! This is fantastic. Where are we! What has happened. I tug at the controls again. They will not respond!!!! We are caught in an invisible vice grip of some type!

1135 Hours- Our radio crackles and a voice comes through in English with what perhaps is a slight Nordic or Germanic accent! The message is: 'Welcome, Admiral, to our domain. We shall land you in exactly seven minutes! Relax, Admiral, you are in good hands.' I note the engines of our plane have stopped running! The aircraft is under some strange control and is now turning itself. The controls are useless.

1140 Hours- Another radio message received. We begin the landing process now, and in moments the plane shudders slightly, and begins a descent as though caught in some great

'Final Battalion'

unseen elevator! The downward motion is negligible, and we touch down with only a slight jolt!

1145 Hours- I am making a hasty last entry in the flight log. Several men are approaching on foot toward our aircraft. They are tall with blond hair. In the distance is a large shimmering city pulsating with rainbow hues of color. I do not know what is going to happen now, but I see no signs of weapons on those approaching. I hear now a voice ordering me by name to open the cargo door. I comply. END LOG

From this point I write all the following events here from memory. It defies the imagination and would seem all but madness if it had not happened.

The radioman and I are taken from the aircraft and we are received in a most cordial manner. We were then boarded on a small platform-like conveyance with no wheels! It moves us toward the glowing city with great swiftness. As we approach, the city seems to be made of a crystal material. Soon we arrive at a large building that is a type I have never seen before. It appears to be right out of the design board of Frank Lloyd Wright, or perhaps more correctly, out of a Buck Rogers setting!! We are given some type of warm beverage which tasted like nothing I have ever savored before. It is delicious. After about ten minutes, two of our wondrous appearing hosts come to our quarters and announce that I am to accompany them. I have no choice but to comply. I leave my radioman behind and we walk a short distance and enter into what seems to be an elevator. We descend downward for some moments, the machine stops, and the door lifts silently upward! We then proceed down a long hallway that is lit by a rose-colored light that seems to be emanating from the very walls themselves! One of the beings motions for us to stop before a great door. Over the door is an inscription that I cannot read. The great door slides noiselessly open and I am beckoned to enter. One of my hosts speaks. 'Have no fear, Admiral, you are to have an audience with the Master...'

I step inside and my eyes adjust to the beautiful coloration that seems to be filling the room completely. Then I begin to see my surroundings. What greeted my eyes is the most beautiful sight of my entire existence. It is in fact too beautiful and wondrous to describe. It is exquisite and delicate. I do not think there exists a

human term that can describe it in any detail with justice! My thoughts are interrupted in a cordial manner by a warm rich voice of melodious quality, 'I bid you welcome to our domain, Admiral.' I see a man with delicate features and with the etching of years upon his face. He is seated at a long table. He motions me to sit down in one of the chairs. After I am seated, he places his fingertips together and smiles. He speaks softly again, and conveys the following.

'We have let you enter here because you are of noble character and well-known on the Surface World, Admiral.' Surface World, I half-gasp under my breath! 'Yes," the Master replies with a smile, 'you are in the domain of the Arianni, the Inner World of the Earth. We shall not long delay your mission, and you will be safely escorted back to the surface and for a distance beyond. But now, Admiral, I shall tell you why you have been summoned here. Our interest rightly begins just after your race exploded the first atomic bombs over Hiroshima and Nagasaki, Japan. It was at that alarming time we sent our flying machines, the "Flugelrads", to your surface world to investigate what your race had done. That is, of course, past history now, my dear Admiral, but I must continue on. You see, we have never interfered before in your race's wars and barbarity, but now we must, for you have learned to tamper with a certain power that is not for man, namely, that of atomic energy. Our emissaries have already delivered messages to the powers of your world, and yet they do not heed. Now you have been chosen to be witness here that our world does exist. You see, our Culture and Science is many thousands of years beyond your race, Admiral.' I interrupted, 'But what does this have to do with me, Sir?'

The Master's eyes seemed to penetrate deeply into my mind, and after studying me for a few moments he replied, 'Your race has now reached the point of no return, for there are those among you who would destroy your very world rather than relinquish their power as they know it...' I nodded, and the Master continued, 'In 1945 and afterward, we tried to contact your race, but our efforts were met with hostility, our Flugelrads were fired upon. Yes, even pursued with malice and animosity by your fighter planes. So, now, I say to you, my son, there is a great storm gathering in your world, a black fury that will not spend

itself for many years. There will be no answer in your arms, there will be no safety in your science. It may rage on until every flower of your culture is trampled, and all human things are leveled in vast chaos. Your recent war was only a prelude of what is yet to come for your race. We here see it more clearly with each hour. do you say I am mistaken?'

'No,' I answer, 'it happened once before, the dark ages came and they lasted for more than five hundred years.'

'Yes, my son,' replied the Master, 'the dark ages that will come now for your race will cover the Earth like a pall, but I believe that some of your race will live through the storm, beyond that, I cannot say. We see at a great distance a new world stirring from the ruins of your race, seeking its lost and legendary treasures, and they will be here, my son, safe in our keeping. When that time arrives, we shall come forward again to help revive your culture and your race. Perhaps, by then, you will have learned the futility of war and its strife...and after that time, certain of your culture and science will be returned for your race to begin anew. You, my son, are to return to the Surface World with this message.....'

With these closing words, our meeting seemed at an end. I stood for a moment as in a dream....but, yet, I knew this was reality, and for some strange reason I bowed slightly, either out of respect or humility, I do not know which.

Suddenly, I was again aware that the two beautiful hosts who had brought me here were again at my side. 'This way, Admiral,' motioned one. I turned once more before leaving and looked back toward the Master. A gentle smile was etched on his delicate and ancient face. 'Farewell, my son,' he spoke, then he gestured with a lovely, slender hand a motion of peace and our meeting was truly ended.

Quickly, we walked back through the great door of the Master's chamber and once again entered into the elevator. The door slid silently downward and we were at once going upward. One of my hosts spoke again, 'We must now make haste, Admiral, as the Master desires to delay you no longer on your scheduled timetable and you must return with his message to your race.'

I said nothing. All of this was almost beyond belief, and once again my thoughts were interrupted as we stopped. I entered the

room and was again with my radioman. He had an anxious expression on his face. As I approached, I said, 'It is all right, Howie, it is all right.' The two beings motioned us toward the awaiting conveyance, we boarded, and soon arrived back at the aircraft. The engines were idling and we boarded immediately. The whole atmosphere seemed charged now with a certain air of urgency. After the cargo door was closed the aircraft was immediately lifted by that unseen force until we reached an altitude of 2700 feet. Two of the aircraft were alongside for some distance guiding us on our return way. I must state here, the airspeed indicator registered no reading, yet we were moving along at a very rapid rate.

215 Hours- A radio message comes through. 'We are leaving you now, Admiral, your controls are free. Auf Wiedersehen!!!!' We watched for a moment as the flugelrads disappeared into the pale blue sky.

The aircraft suddenly felt as though caught in a sharp downdraft for a moment. We quickly recovered her control. We do not speak for some time, each man has his thoughts....

ENTRY IN FLIGHT LOG CONTINUES:

220 Hours- We are again over vast areas of ice and snow, and approximately 27 minutes from base camp. We radio them, they respond. We report all conditions normal....normal. Base camp expresses relief at our re-established contact.

300 Hours- We land smoothly at base camp. I have a mission.....
END LOG ENTRIES.

March 11, 1947. I have just attended a staff meeting at the Pentagon. I have stated fully my discovery and the message from the Master. All is duly recorded. The President has been advised. I am now detained for several hours (six hours, thirty- nine minutes, to be exact.) I am interviewed intently by Top Security Forces and a medical team. It was an ordeal!!!! I am placed under strict control via the national security provisions of this United States of America. I am ORDERED TO REMAIN SILENT IN REGARD TO ALL THAT I HAVE LEARNED, ON THE BEHALF OF HUMANITY1111 Incredible! I am reminded that I am a military man and I must obey orders.

30/12/56: FINAL ENTRY:

'Final Battalion'

These last few years elapsed since 1947 have not been kind...I now make my final entry in this singular diary. In closing, I must state that I have faithfully kept this matter secret as directed all these years. It has been completely against my values of moral right. Now, I seem to sense the long night coming on and this secret will not die with me, but as all truth shall, it will triumph and so it shall.

This can be the only hope for mankind. I have seen the truth and it has quickened my spirit and has set me free! I have done my duty toward the monstrous military industrial complex. Now, the long night begins to approach, but there shall be no end. Just as the long night of the Arctic ends, the brilliant sunshine of Truth shall come again....and those who are of darkness shall fall in it's Light. FOR I HAVE SEEN THAT LAND BEYOND THE POLE, THAT CENTER OF THE GREAT UNKNOWN.

Admiral Richard E. Byrd
United States Navy
24 December 1956

The Right Perspective

“First the Russians are going to be considered to be the enemy. In fact, in 1974, they were the enemy, the identified enemy. Then terrorists would be identified, and that was soon to follow. We heard a lot about terrorism. But he said that the third enemy would be against whom we would build space-based weapons. The next enemy was asteroids. Now, at this point he kind of chuckled the first time he said it. Asteroids - against asteroids we are going to build space-based weapons. And the funniest one of all was what he called aliens, extraterrestrials. That would be the final scare. And over and over and over during the four years that I knew him and was giving speeches for him, he would bring up that last card. “And remember Carol, the last card is the alien card. We are going to have to build space-based weapons against aliens and all of it is a lie.”

-As told by Wernher von Braun’s assistant, Dr. Carol Rosin

To truly comprehend the continuation of the Hitler loyalists in the Southern end of the world we should step back and put events in order. On the map below we have marked areas of interest and we shall make an effort to discuss them in order.

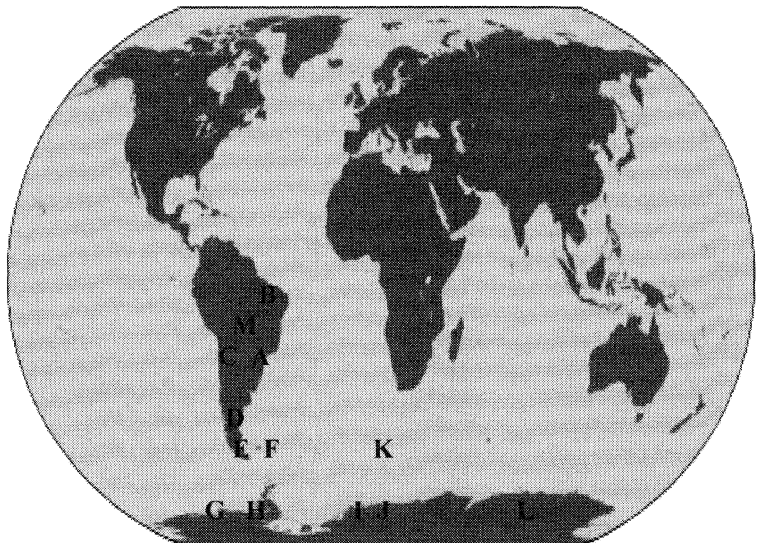

‘Final Battalion’

A. Argentina’s Juan and ‘Evita’ Peron were National Socialists. Their effectiveness in aiding German fugitives came by way of Catholicism. Catholic Priests authorized tens of thousands Baptismal Certificates. A Baptismal Certificate was as good as a Birth Certificate in most of South America. Today, Germans make up the third largest population in Argentina. They had set up networks of Colonies. Colonies were a refuge and ‘Outpost’.

B. Brazil had many thousand German immigrants, again we are dealing with ‘Colonies’ and their research. We should point out that the ‘research’ and immigration had been going on for some time. Those Aryan adventurers were looking for something.

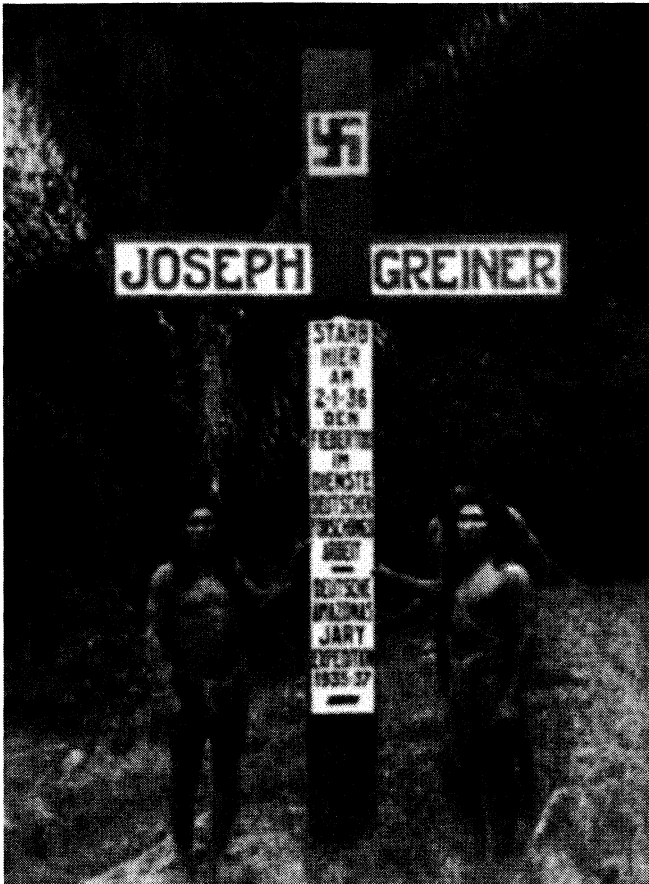

Greiner died in 1936 on an S.S. expedition into the Amazon jungle.

C. Chile has an infamous Colony named Colonia Dignidad. The fabricated assaults on 'Colony of Dignity' do become downright repulsive. On another note, the conspiracy theorists claim a recent '8.8 earthquake' was a 'New World Order' attack on an underground German facility near Colonia Dignidad. As farfetched as it may seem, it does coincide with the only actual report ever given on the Colony. An 'El Mercurio' reporter allegedly backpacked his way close enough to witness 'strange flying crafts' landing and taking off from a valley near Colonia Dignidad. Mattern ascertains that it was an exchange location for fresh goods and such. We do agree.

D. The Patagonia has countless reports of German activity before and after 1945. We will return to this Mystical Land later.

E. Tierra del Fuego is the very southern tip of South America. It has been rumored to be another drop off and pick up point ever since the crew of the Graf Spee scuttled their Battleship in 1939. Coincidentally, most of the Graf Spee crew developed a colony near Cordoba, Argentina. Today, it is a popular tourist attraction named Villa General Belgrano.

F. The Falkland Islands have been under British control since 1833, that is, except for during the Argentine offensive in 1982. The claims to the Falklands and surrounding Islands is still hotly debated up to the present day. And in 1982 the world learned of the British having an arsenal of nuclear weapons in the Falklands. The natural question would be – Why?

G. Admiral Byrd's Little America - 'Operation Highjump'.

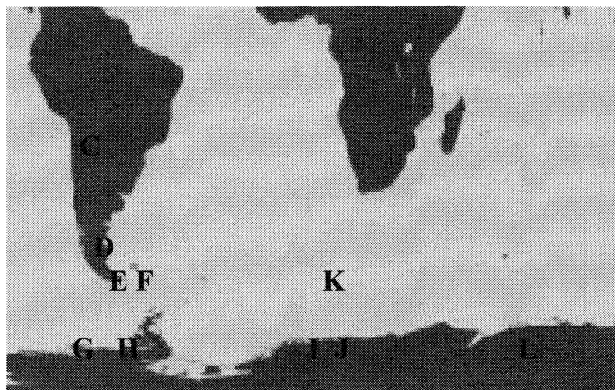

H. Port Lockroy - ‘Operation Tabarin’.

I. Maudheim base.

J. Muhlig-Hofmann Mountain Range.

K. ‘Operation Argus’ - ‘the only clandestine test series in the 17 year history of atmospheric testing. It was secretly conducted in the South Atlantic, 1100 miles southwest of Capetown, South Africa. Argus consisted of three very high altitude test shots of the W-25 warhead to investigate the effects of nuclear explosions outside of the atmosphere - how the charged particles and radioactive isotopes released would interact with the Earth's magnetic field which could potentially interfere with radar tracking, communications, and the electronics of satellites and ballistic missiles.’

In the early Autumn of 1958, the U.S. government claims to have made an ‘artificial Van Allen Belt’ (an enormous hole in the atmosphere). By ‘chance’ these clandestine nuclear explosions were detonated directly North of the Muhlig-Hofmann Mountains. The team that conducted the operation was the Top Secret Task Force 88. At the very least, this was an attempt to disable German satellite communications (the Germans had been working on space satellites since the thirties). At this point, we prefer not to speculate any further. Let us take a quick look at one of the codenames of these operations, for it tells us the story. ‘Argus’ literally means ‘all eyes’, Argus was conducted by Task force ‘88’.

L. Lake Vostok is under the Russian Vostok Station. It is said to be the largest lake known of in the Antarctic. The Russians have been attempting to drill through over 2 miles of ice for many years and in May of 2012 they did. Since then an array of stories have surfaced. Samples of extraterrestrial life in the water, a 300 ft. Golden Swastika on the lake’s bottom, magnetic ‘anomalies’, 60 degree temperatures, a ‘Nazi’ base, Martian rocks and so on. The research teams do admit; the lake is geothermal (warm), there is a definite magnetic disturbance and unseen before life samples. Interestingly, the Americans are suppose to be comparing research in conjunction with a flight to Jupiter’s moon, Aurora, because of ‘similar conditions’. It is said that the Antarctic rocks from Mars could only have landed here from the force of a catastrophic event. These tidbits should remind us of

the 'asteroid belt' between Mars and Jupiter, a remnant of a great World that once was but is no more. Known by many names, we may as well call it 'Krypton' because it is from there that came the Superman. With a little research one can find several legends of the existence and destruction of that Golden Age world. What is not exactly clear is whether the earth was an actual part of that lost world and was flung to our present position in the Galaxy, or if something from there landed here. Either way, life from there is now here and it lives in us.

M. Paraguay had the first National Socialists Party outside of Germany. Bernhard Forster, who had married Elisabeth Nietzsche (the philosopher's sister), founded the German Colony named 'Nueva Germania' in the 19th century. Forster had been a famous 'Antisemite' in Germany. Distraught with the Jewish influence and power in Europe, the Forsters migrated to Paraguay to begin a pure Aryan colony. Members of 'Nueva Germania' organized a National Socialist party in 1931.

There is good reason why we saved Paraguay for last. This small nation in the middle of South America is at the heart of the matter. As we have said, these 'Colonies' are Outposts. There are many worlds within this world. The loyal adherents of Adolf Hitler were permitted access to the other earth or 'a Seventh Heaven', which may be a name easier to comprehend. To begin revealing that which is hidden, The Northmen of Paraguay is a fine place to start.

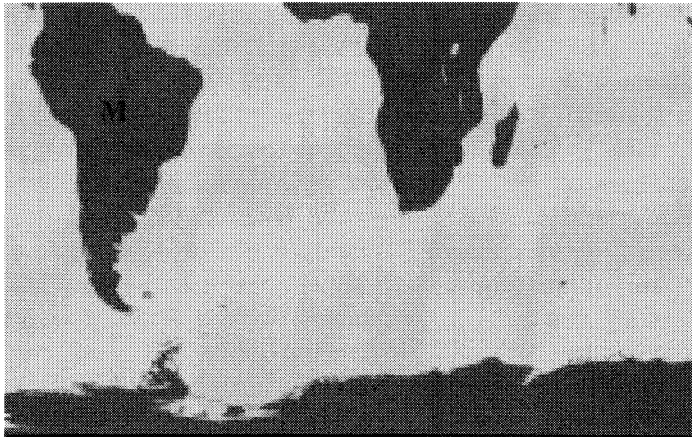

Northmen of Paraguay

It has been proven that 'Vikings' settled the surrounding region of small mountains in the Cerro Cora area of Paraguay. There are well documented ancient Nordic ruins, Altars dedicated to Odin and thousands of runic inscriptions. The Guarani tribes of Paraguay, Brazil and Bolivia recall this Aryan civilization and White King of antiquity:

"In days gone by, there reigned in this region a powerful and wise king called Ipir. He was a white man and wore a long blond beard. With men of his race and indigenous warriors loyal to him he lived in a large settlement on top of a small mountain."

The earliest Conquistadors also confirmed his existence.

In 1940, the National Socialist researcher and mystic, Fritz Berger, working in cooperation with the Paraguayan Army, discovered a city he called 'Atlantik'. It is claimed that he had a vision of a people who told him to come to Paraguay to find his answers. Berger reported: "Cerro Ipir was the centre of a vast region densely populated aeons ago." Berger also claimed that the Knights Templar had traveled to this land.

Later, Professor Jacques de Mahieu, who had been an Officer in one of the most glorious and heroic fighting units in all of history, the French S.S. Division 'Charlemagne', would carry out his own research at Cerro Ipir. He wrote extensively about his findings.

It was determined that the mountain had been increased in height and made fortified. Below the mountain is an underground chamber/door made of a concrete material that cannot be broken. The Guarani tribes knew of it and called it the 'King's Chamber'. We find this theme over and over wherever the Aryan has went. Always the 'Wounded King' (our Father), who is not dead, but only sleeps...

The next questions would be; Why were the Northmen there? Who was King Ipir? What were the Templars doing there? And why were the 'Aryan thinking' Germans attracted to the region?

The Prophecy of Ostara is coming full circle right before us.

We are most fortunate to have the teachings of Master Serrano. Jacques de Mahieu and Miguel Serrano were friends and post-war Comrades. In the masterpiece, *Nos, Book of the Resurrection*, Serrano reveals:

“I am reading a book which no one else in my country has yet read. Father Jacques, a member of our order, will be publishing it shortly, reproducing it from our archives...It is the unknown story of the Princess Papan.

In pre-recorded times, when the Hyperboreans realized that their continent in the Polar North was going to be submerged, they sent one of their Discs of orichalcum to the South of the world. And with its crew went the Priestess of Magic Love, Allouine. They took with them a branch from the Soma tree, which was the tree that contained the liquor of blood, of Blood Memory. And they planted it at the other pole. When the continent of Hyperborea disappeared, together with the first Atlantis, Mu and Gondwana, the White Gods were already safe in the oases at the South Pole and in the secret cities in the Andes. They founded the ancient civilization of Tiahuanacu and the temples of Easter Island which have now disappeared. The White Gods were men of giant stature...

When the earth's axis shifted, the Golden Age, the Garden of Avalon and the First Earth were lost. The seasons were introduced, time was born. But in the hollow Interior Earth, in its 'double,' in the secret cities of Agharti and Shambhalla, in Great Paytiti, in Elelin, in the City of the Caesars, in all those places, the Golden Age has been preserved...

Through their Blood Memory they knew that a branch of the original, primeval Soma tree grew at the South Pole. And they had to go there to drink its immortalizing liquor. Only in this way could they be rejuvenated, bringing new life to the Divine Race which was on the point of extinction. For this reason, in ancient times America-Albania was visited by the Druids, the Celts, the Vikings, the Templars, and Parsifal, who came in a ship with all its lights on, with the emblem of the Lefthanded Cross on its sail and carrying the Graal. The ship was called *Wafeln, El Caleuche, Astra*. It navigated beneath the surface of the water and was crewed by the souls of the dead heroes, the

Wildes Heer, the defeated armies of the war of the *Mahabharata*, the great war which will never end.

The surface of America-Albania, which the Vikings called *Hvetramannaland*, the Land of White Men, is populated to the present day by the slaves who survived the sinking of Atlantis, who did sink it with their black magic... They rebelled, causing the catastrophe, by consorting indiscriminately with each other, without initiatory knowledge, without tantric magic, without science, bringing about a most terrible cataclysm, as Plato relates. Atlantis severed the ties which joined it to Hyperborea - the sacred land of the extraterrestrial guides of the Radiant Green Light - and its sinking produced the planetary, cosmic drama, tearing away even the Polar Continent, shifting the earth's axis, causing the third moon to fall on Gondwana, changing the position of the Andean Ocean, destroying Tiahuanacu, submerging the Continent of the Spirit. Homer also relates that the Garden of the Hesperides, with its apples of alchemical gold, of *aurum potabile*, which can be eaten and drunk, was guarded by three sisters, one white, one black and one red, *Albedo*, *Nigredo* and *Rubedo* were said to be their names. The complete planetary *Opus alchimicum*. But everything changed, becoming degenerate. The original magico-Hyperborean science was lost. And as in Tibet, where the Mongol race became the outer, faithful guardian of the entrances to the interior world of the giant Dropas and the divine Siddhas of Agharti, the sole purpose of the colored races of American-Albania was to watch over the entrances to the secret cities of the Andes and the Internal Land of the divine *Ancahuincas*, the immortal White Gods...

The Vikings came in search of the Soma tree, the tree of Blood Memory. They created an entire civilization in ancient Mexico. The slaves of Atlantis received them with that mixture of respect which the atavistic memory of a glorious age produces in them, which makes them bow down in reverence, but there was also the sly arrogance of those who believe themselves capable of disregarding the Norns. The Viking chieftain was called Ullman, man of Ull, according to Father Jacques. He founded an important civilization in ancient Mexico and in the land of the Mayas, where he was called Quetzalcoatl, the Serpent with Fiery Plumes, because of the *Drakkar*, the Viking ship in which he had

come and which appeared to have wings and plumes, and all its lights on, turning like a luminous disc, sometimes in the full light of midday. But the most extraordinary thing that Father Jacques relates in this book, which he hasn't yet written, is that Quetzalcoatl's Beloved was called Papan-Allouine. That is to say that the Princess Papan of the Aztec legend was not the sister of Moctezuma, who might also have been a Viking, because he swore that he came from Tula or Thule, but a semi-divine Hyperborean priestess, who came to *Hvetramannaland*, Albania, in the Disc called *Astra* or *Wafeln*, with Quetzalcoatl.

And when Quetzalcoatl went away, no one knows where to (the Interior Earth or the Morning Star?), Papan became 'as if dead,' not in Tenochtitlan but much further south, in a region near the other pole in a secret city in the Andes possibly near the peak of Mount Melimoyu. Because before he went away forever, the man of Ull went southward, ever farther southward. And it was Quetzalcoatl who rebuilt the civilization of Tiahuanacu, taking other names. He was called Tamanduare, Sue-ca, Kontiki-Viracocha, Pay Zume, Manko Kapak. Papan was called Neua and also Mama Occl and Mama Runtu. She was the Queen of Sheba; because *Sheba* means South."

We are well aware that the winged-words of Master Serrano are for the awakening Hyperborean Spirit. Therefore, in the next couple of chapters we will attempt, step by step, a dry and factual account of events to present an outline of this pre-recorded history. And in this saga, if the reader can bear with us, we will illustrate how it is all connected. It is an unbroken story that spans well over 12,000 years. One cannot truly comprehend the U.F.O. without the knowledge of from whence this technology came.

The Third Reich had help and to understand this 'Helper', that is, to comprehend whom they represented, we must go back many thousands of years to a very long and glorious history that has been kept from us. Why? Because they are afraid of you and I finding out the truth and waking up to the fact that we have much to be angry about, but also that there is a road of hope open for those who care to achieve it.

come and which appeared to have wings and plumes, and all its lights on, turning like a luminous disc, sometimes in the full light of midday. But the most extraordinary thing that Father Jacques relates in this book, which he hasn't yet written, is that Quetzalcoatl's Beloved was called Papan-Allouine. That is to say that the Princess Papan of the Aztec legend was not the sister of Moctezuma, who might also have been a Viking, because he swore that he came from Tula or Thule, but a semi-divine Hyperborean priestess, who came to *Hvetramannaland*, Albania, in the Disc called *Astra* or *Wafeln*, with Quetzalcoatl.

And when Quetzalcoatl went away, no one knows where to (the Interior Earth or the Morning Star?), Papan became 'as if dead,' not in Tenochtitlan but much further south, in a region near the other pole in a secret city in the Andes possibly near the peak of Mount Melimoyu. Because before he went away forever, the man of Ull went southward, ever farther southward. And it was Quetzalcoatl who rebuilt the civilization of Tiahuanacu, taking other names. He was called Tamanduaire, Sue-ca, Kontiki-Viracocha, Pay Zume, Manko Kapak. Papan was called Neua and also Mama Occl and Mama Runtu. She was the Queen of Sheba; because *Sheba* means South."

We are well aware that the winged-words of Master Serrano are for the awakening Hyperborean Spirit. Therefore, in the next couple of chapters we will attempt, step by step, a dry and factual account of events to present an outline of this pre-recorded history. And in this saga, if the reader can bear with us, we will illustrate how it is all connected. It is an unbroken story that spans well over 12,000 years. One cannot truly comprehend the U.F.O. without the knowledge of from whence this technology came.

The Third Reich had help and to understand this 'Helper', that is, to comprehend whom they represented, we must go back many thousands of years to a very long and glorious history that has been kept from us. Why? Because they are afraid of you and I finding out the truth and waking up to the fact that we have much to be angry about, but also that there is a road of hope open for those who care to achieve it.

come and which appeared to have wings and plumes, and all its lights on, turning like a luminous disc, sometimes in the full light of midday. But the most extraordinary thing that Father Jacques relates in this book, which he hasn't yet written, is that Quetzalcoatl's Beloved was called Papan-Allouine. That is to say that the Princess Papan of the Aztec legend was not the sister of Moctezuma, who might also have been a Viking, because he swore that he came from Tula or Thule, but a semi-divine Hyperborean priestess, who came to *Hvetramannaland*, Albania, in the Disc called *Astra* or *Wafeln*, with Quetzalcoatl.

And when Quetzalcoatl went away, no one knows where to (the Interior Earth or the Morning Star?), Papan became 'as if dead,' not in Tenochtitlan but much further south, in a region near the other pole in a secret city in the Andes possibly near the peak of Mount Melimoyu. Because before he went away forever, the man of Ull went southward, ever farther southward. And it was Quetzalcoatl who rebuilt the civilization of Tiahuanacu, taking other names. He was called Tamanduaire, Sue-ca, Kontiki-Viracocha, Pay Zume, Manko Kapak. Papan was called Neua and also Mama Ocel and Mama Runtu. She was the Queen of Sheba; because *Sheba* means South."

We are well aware that the winged-words of Master Serrano are for the awakening Hyperborean Spirit. Therefore, in the next couple of chapters we will attempt, step by step, a dry and factual account of events to present an outline of this pre-recorded history. And in this saga, if the reader can bear with us, we will illustrate how it is all connected. It is an unbroken story that spans well over 12,000 years. One cannot truly comprehend the U.F.O. without the knowledge of from whence this technology came.

The Third Reich had help and to understand this 'Helper', that is, to comprehend whom they represented, we must go back many thousands of years to a very long and glorious history that has been kept from us. Why? Because they are afraid of you and I finding out the truth and waking up to the fact that we have much to be angry about, but also that there is a road of hope open for those who care to achieve it.

‘Final Battalion’

‘Paradise Lost’

Hyperborea is Paradise

“With golden laurel binding their hair they feast in gladness.
Neither disease nor hateful age are mingled
With that holy race; without toil or war
They live escaping avenging Nemesis.”

- Pindar

Men have been contemplating a lost Golden Age since time began. This should be taken literally because to fall into time is to lose that place beyond time, that place of God, which is, the Heavens. Whether it be the old legends of Atlantis, the cryptic Arcadia, Avalon, Aldebaran or Antarctica, we are really speaking of the same idea. A Paradise that still exists in some form and is just beyond our reach. The Land beyond the Poles.

The Myths and legends teach us of this. The door was shut to Paradise and the Graal was taken away from the sight of men. When they speak of those who fell they are referring to us. It is the story of the prodigal son. The way back is to first remember who we are.

To remember the lost homeland is not impossible. Most of us have an innate sense that there was once something greater and also a foreboding of some future catastrophic event. It is the saga of the eternal return. Intuitively, we know this and there is much evidence to confirm our feelings. The *Mahabharata* is full of such references to a time and place that had no need of threats of consequences, because men still had the intelligence to sincerely strive for that which is best.

“Men neither bought nor sold; there were no poor and no rich; there was no need to labour, because all that men required was obtained by the power of will; the chief virtue was the abandonment of all worldly desires. The Krita Yuga was without disease; there was no lessening with the years; there was no hatred or vanity, or evil thought whatsoever; no sorrow, no fear. All mankind could attain to supreme blessedness.”

The *Mahabharata* also speaks of “Atala, the White Island”, a land of splendor, which, was originally populated by a race known for their fair complexion and their devotion to Narayana (a name for the all pervading Vishnu, who is, the God of the Avatar and the great Supreme). The Vedic Aryans of India were not alone. We have been handed down a vast amount of references to a lost world of a perfect Age by ancient Greece.

The Greek philosopher Empedocles, who is credited with being the first to illustrate upon the four elements (earth, air, fire, water), wrote of a lost age which he longed for:

“There every animal was tame and familiar with men, both beasts and birds, and mutual love prevailed. Trees flourished with perpetual leaves and fruits, and ample crops adorned their boughs through all the year. Nor had these happy people any Ares or mad Uproar for their god; The altars did not reek with bullocks' gore.”

Empedocles proved his belief in a Hyperborea with his ‘death’. To this day the materialists poke fun at his leap into Mount Etna, from which, he would not be seen again. What can make a place, an idea, so wonderful that one of the greatest minds of his time would cast himself into a volcano with the hope of reaching immortality?

It is the Roman Virgil who answered our question:

“The age was formed of gold; in those first days. No law or force was needed; men did right of their own accord; without duress they kept their word.”

They kept their word! It is their love for Honor that made Paradise. All that is Loyal and Honest is the secret of Paradise. Heaven is wherever these divine traits rule, for they are of God. This is why, time and again, we return to those few words that describe Honor. These ideals are so simple and yet impossible for the children of mammon, who are also known as the ‘slaves of Atlantis’, to live by. The ‘slaves of Atlantis’, just as the slaves of Egypt, brought nothing but corruption and turmoil to the *last* golden land (some things never change).

The story of Atlantis was revisited and gained momentum by the 1882 release of Ignatius Donnelly's book, *Atlantis, the Antediluvian World*. Donnelly has been recognized for his work bringing forth knowledge of Atlantis that has swept the world for the last century. He wrote of several legends from many different cultures of the past, by which, he adequately proved his case for the existence of Atlantis. The overall message of his less known second work, *Ragnarok: The Age of Fire and Gravel*, which was published one year later can be found in this quote:

"The pre-glacial world was a garden, a paradise; not excessively warm at the equator, and yet with so mild and equable a climate that the plants we now call tropical flourished within the present Arctic Circle. If some future daring navigator reaches the north pole and finds solid land there, he will probably discover in the rocks at his feet the fossil remains of the oranges and bananas of the pre-glacial age."

While we may not agree with all of his conclusions, it is quite obvious that his Hyperborean blood was stirring in order to make such a statement. He understood that the earth was not always as it is now and that a vast history had been 'forgotten'. A forgotten history that includes the starry Heavens. And although it be true that Hyperborea's Thule is a much older and nobler concept, it is the story of Atlantis that seems to attract most minds. We believe that this is because the destruction of Atlantis is so close to our own present circumstance.

“

Plato's Atlantis

It is Plato who is generally credited with giving us the first full account of Atlantis. While most are aware of this, few have actually read the words of Plato. As long as it may be, we feel that the detailed information is pertinent to our story. Here follows the Atlantean story told by Plato in *Critias*:

“I have before remarked in speaking of the allotments of the gods, that they distributed the whole earth into portions differing in extent, and made for themselves temples and instituted sacrifices. Poseidon, receiving for his lot the island of Atlantis, begat children by a mortal woman, and settled them in a part of the island, which I will describe. Looking towards the sea, but in the centre of the whole island, there was a plain which is said to have been the fairest of all plains and very fertile. Near the plain, and also in the centre of the island at a distance of about fifty stadia, there was a mountain not very high on any side. In this mountain there dwelt one of the earth born primeval men of that country, whose name was Evenor, and he had a wife named Leucippe, and they had an only daughter who was called Cleito. The maiden had already reached womanhood, when her father and mother died; Poseidon fell in love with her and had intercourse with her, and breaking the ground, enclosed the hill in which she dwelt all round, making alternate zones of sea and land larger and smaller, encircling one another; there were two of land and three of water, which he turned as with a lathe, each having its circumference equidistant every way from the centre, so that no man could get to the island, for ships and voyages were not as yet. He himself, being a god, found no difficulty in making special arrangements for the centre island, bringing up two springs of water from beneath the earth, one of warm water and the other of cold, and making every variety of food to spring up abundantly from the soil.”

He also begat and brought up five pairs of twin male children; and dividing the island of Atlantis into ten portions, he gave to the first-born of the eldest pair his mother's dwelling and the surrounding allotment, which was the largest and best, and made him king over the rest; the others he made princes, and gave

them rule over many men, and a large territory. And he named them all; the eldest, who was the first king, he named Atlas, and after him the whole island and the ocean were called Atlantic. To his twin brother, who was born after him, and obtained as his lot the extremity of the island towards the Pillars of Heracles, facing the country which is now called the region of Gades in that part of the world, he gave the name which in the Hellenic language is Eumelus, in the language of the country which is named after him, Gadeirus. Of the second pair of twins he called one Ampheres, and the other Evaemon. To the elder of the third pair of twins he gave the name Mneseus, and Autochthon to the one who followed him. Of the fourth pair of twins he called the elder Elasippus, and the younger Mestor. And of the fifth pair he gave to the elder the name of Azaes, and to the younger that of Diaprepes. All these and their descendants for many generations were the inhabitants and rulers of divers islands in the open sea; and also, as has been already said, they held sway in our direction over the country within the Pillars as far as Egypt and Tyrrhenia.

Now Atlas had a numerous and honorable family, and they retained the kingdom, the eldest son handing it on to his eldest for many generations; and they had such an amount of wealth as was never before possessed by kings and potentates, and is not likely ever to be again, and they were furnished with everything which they needed, both in the city and country. For because of the greatness of their empire many things were brought to them from foreign countries, and the island itself provided most of what was required by them for the uses of life. In the first place, they dug out of the earth whatever was to be found there, solid as well as fusile, and that which is now only a name and was then something more than a name, orichalcum, was dug out of the earth in many parts of the island, being more precious in those days than anything except gold. There was an abundance of wood for carpenter's work, and sufficient maintenance for tame and wild animals. Moreover, there were a great number of elephants in the island; for as there was provision for all other sorts of animals, both for those which live in lakes and marshes and rivers, and also for those which live in mountains and on plains, so there was for the animal which is the largest and most

voracious of all. Also whatever fragrant things there now are in the earth, whether roots, or herbage, or woods, or essences which distil from fruit and flower, grew and thrived in that land; also the fruit which admits of cultivation, both the dry sort, which is given us for nourishment and any other which we use for food—we call them all by the common name pulse, and the fruits having a hard rind, affording drinks and meats and ointments, and good store of chestnuts and the like, which furnish pleasure and amusement, and are fruits which spoil with keeping, and the pleasant kinds of dessert, with which we console ourselves after dinner, when we are tired of eating—all these that sacred island which then beheld the light of the sun, brought forth fair and wondrous and in infinite abundance. With such blessings the earth freely furnished them; meanwhile they went on constructing their temples and palaces and harbours and docks. And they arranged the whole country in the following manner: First of all they bridged over the zones of sea which surrounded the ancient metropolis, making a road to and from the royal palace. And at the very beginning they built the palace in the habitation of the god and of their ancestors, which they continued to ornament in successive generations, every king surpassing the one who went before him to the utmost of his power, until they made the building a marvel to behold for size and for beauty. And beginning from the sea they bored a canal of three hundred feet in width and one hundred feet in depth and fifty stadia in length, which they carried through to the outermost zone, making a passage from the sea up to this, which became a harbour, and leaving an opening sufficient to enable the largest vessels to find ingress. Moreover, they divided at the bridges the zones of land which parted the zones of sea, leaving room for a single trireme to pass out of one zone into another, and they covered over the channels so as to leave a way underneath for the ships; for the banks were raised considerably above the water. Now the largest of the zones into which a passage was cut from the sea was three stadia in breadth, and the zone of land which came next of equal breadth; but the next two zones, the one of water, the other of land, were two stadia, and the one which surrounded the central island was a stadium only in width. The island in which the palace was situated had a diameter of

five stadia. All this including the zones and the bridge, which was the sixth part of a stadium in width, they surrounded by a stone wall on every side, placing towers and gates on the bridges where the sea passed in. The stone which was used in the work they quarried from underneath the centre island, and from underneath the zones, on the outer as well as the inner side. One kind was white, another black, and a third red, and as they quarried, they at the same time hollowed out double docks, having roofs formed out of the native rock. Some of their buildings were simple, but in others they put together different stones, varying the color to please the eye, and to be a natural source of delight. The entire circuit of the wall, which went round the outermost zone, they covered with a coating of brass, and the circuit of the next wall they coated with tin, and the third, which encompassed the citadel, flashed with the red light of orichalcum.

The palaces in the interior of the citadel were constructed on this wise:-in the centre was a holy temple dedicated to Cleito and Poseidon, which remained inaccessible, and was surrounded by an enclosure of gold; this was the spot where the family of the ten princes first saw the light, and thither the people annually brought the fruits of the earth in their season from all the ten portions, to be an offering to each of the ten. Here was Poseidon's own temple which was a stadium in length, and half a stadium in width, and of a proportionate height, having a strange barbaric appearance. All the outside of the temple, with the exception of the pinnacles, they covered with silver, and the pinnacles with gold. In the interior of the temple the roof was of ivory, curiously wrought everywhere with gold and silver and orichalcum; and all the other parts, the walls and pillars and floor, they coated with orichalcum. In the temple they placed statues of gold: there was the god himself standing in a chariot-the charioteer of six winged horses-and of such a size that he touched the roof of the building with his head; around him there were a hundred Nereids riding on dolphins, for such was thought to be the number of them by the men of those days. There were also in the interior of the temple other images which had been dedicated by private persons. And around the temple on the outside were placed statues of gold of all the descendants of the

ten kings and of their wives, and there were many other great offerings of kings and of private persons, coming both from the city itself and from the foreign cities over which they held sway. There was an altar too, which in size and workmanship corresponded to this magnificence, and the palaces, in like manner, answered to the greatness of the kingdom and the glory of the temple.

In the next place, they had fountains, one of cold and another of hot water, in gracious plenty flowing; and they were wonderfully adapted for use by reason of the pleasantness and excellence of their waters. They constructed buildings about them and planted suitable trees, also they made cisterns, some open to the heavens, others roofed over, to be used in winter as warm baths; there were the kings' baths, and the baths of private persons, which were kept apart; and there were separate baths for women, and for horses and cattle, and to each of them they gave as much adornment as was suitable. Of the water which ran off they carried some to the grove of Poseidon, where were growing all manner of trees of wonderful height and beauty, owing to the excellence of the soil, while the remainder was conveyed by aqueducts along the bridges to the outer circles; and there were many temples built and dedicated to many gods; also gardens and places of exercise, some for men, and others for horses in both of the two islands formed by the zones; and in the centre of the larger of the two there was set apart a race-course of a stadium in width, and in length allowed to extend all round the island, for horses to race in. Also there were guardhouses at intervals for the guards, the more trusted of whom were appointed to keep watch in the lesser zone, which was nearer the Acropolis while the most trusted of all had houses given them within the citadel, near the persons of the kings. The docks were full of triremes and naval stores, and all things were quite ready for use. Enough of the plan of the royal palace. Leaving the palace and passing out across the three you came to a wall which began at the sea and went all round: this was everywhere distant fifty stadia from the largest zone or harbour, and enclosed the whole, the ends meeting at the mouth of the channel which led to the sea. The entire area was densely crowded with habitations; and the canal and the largest of the harbours were full of vessels

and merchants coming from all parts, who, from their numbers, kept up a multitudinous sound of human voices, and din and clatter of all sorts night and day.

I have described the city and the environs of the ancient palace nearly in the words of Solon, and now I must endeavour to represent the nature and arrangement of the rest of the land. The whole country was said by him to be very lofty and precipitous on the side of the sea, but the country immediately about and surrounding the city was a level plain, itself surrounded by mountains which descended towards the sea; it was smooth and even, and of an oblong shape, extending in one direction three thousand stadia, but across the centre inland it was two thousand stadia. This part of the island looked towards the south, and was sheltered from the north. The surrounding mountains were celebrated for their number and size and beauty, far beyond any which still exist, having in them also many wealthy villages of country folk, and rivers, and lakes, and meadows supplying food enough for every animal, wild or tame, and much wood of various sorts, abundant for each and every kind of work.

I will now describe the plain, as it was fashioned by nature and by the labours of many generations of kings through long ages. It was for the most part rectangular and oblong, and where falling out of the straight line followed the circular ditch. The depth, and width, and length of this ditch were incredible, and gave the impression that a work of such extent, in addition to so many others, could never have been artificial. Nevertheless, I must say what I was told. It was excavated to the depth of one hundred feet, and its breadth was a stadium everywhere; it was carried round the whole of the plain, and was ten thousand stadia in length. It received the streams which came down from the mountains, and winding round the plain and meeting at the city, was there let off into the sea. Further inland, likewise, straight canals of a hundred feet in width were cut from it through the plain, and again let off into the ditch leading to the sea: these canals were at intervals of a hundred stadia, and by them they brought down the wood from the mountains to the city, and conveyed the fruits of the earth in ships, cutting transverse passages from one canal into another, and to the city. Twice in the year they gathered the fruits of the earth-in winter having the

benefit of the rains of heaven, and in summer the water which the land supplied by introducing streams from the canals.

As to the population, each of the lots in the plain had to find a leader for the men who were fit for military service, and the size of a lot was a square of ten stadia each way, and the total number of all the lots was sixty thousand. And of the inhabitants of the mountains and of the rest of the country there was also a vast multitude, which was distributed among the lots and had leaders assigned to them according to their districts and villages. The leader was required to furnish for the war the sixth portion of a war-chariot, so as to make up a total of ten thousand chariots; also two horses and riders for them, and a pair of chariot-horses without a seat, accompanied by a horseman who could fight on foot carrying a small shield, and having a charioteer who stood behind the man-at-arms to guide the two horses; also, he was bound to furnish two heavy armed soldiers, two slingers, three stone-shooters and three javelin-men, who were light-armed, and four sailors to make up the complement of twelve hundred ships. Such was the military order of the royal city-the order of the other nine governments varied, and it would be wearisome to recount their several differences.

As to offices and honors, the following was the arrangement from the first. Each of the ten kings in his own division and in his own city had the absolute control of the citizens, and, in most cases, of the laws, punishing and slaying whomsoever he would. Now the order of precedence among them and their mutual relations were regulated by the commands of Poseidon which the law had handed down. These were inscribed by the first kings on a pillar of orichalcum, which was situated in the middle of the island, at the temple of Poseidon, whither the kings gathered together every fifth and every sixth year alternately, thus giving equal honor to the odd and to the even number. And when they were gathered together they consulted about their common interests, and enquired if any one had transgressed in anything and passed judgment and before they passed judgment they gave their pledges to one another on this wise:-There were bulls who had the range of the temple of Poseidon; and the ten kings, being left alone in the temple, after they had offered prayers to the god that they might capture the victim which was acceptable to him,

hunted the bulls, without weapons but with staves and nooses; and the bull which they caught they led up to the pillar and cut its throat over the top of it so that the blood fell upon the sacred inscription. Now on the pillar, besides the laws, there was inscribed an oath invoking mighty curses on the disobedient. When therefore, after slaying the bull in the accustomed manner, they had burnt its limbs, they filled a bowl of wine and cast in a clot of blood for each of them; the rest of the victim they put in the fire, after having purified the column all round. Then they drew from the bowl in golden cups and pouring a libation on the fire, they swore that they would judge according to the laws on the pillar, and would punish him who in any point had already transgressed them, and that for the future they would not, if they could help, offend against the writing on the pillar, and would neither command others, nor obey any ruler who commanded them, to act otherwise than according to the laws of their father Poseidon. This was the prayer which each of them-offered up for himself and for his descendants, at the same time drinking and dedicating the cup out of which he drank in the temple of the god; and after they had supped and satisfied their needs, when darkness came on, and the fire about the sacrifice was cool, all of them put on most beautiful azure robes, and, sitting on the ground, at night, over the embers of the sacrifices by which they had sworn, and extinguishing all the fire about the temple, they received and gave judgment, if any of them had an accusation to bring against any one; and when they given judgment, at daybreak they wrote down their sentences on a golden tablet, and dedicated it together with their robes to be a memorial. There were many special laws affecting the several kings inscribed about the temples, but the most important was the following: They were not to take up arms against one another, and they were all to come to the rescue if any one in any of their cities attempted to overthrow the royal house; like their ancestors, they were to deliberate in common about war and other matters, giving the supremacy to the descendants of Atlas. And the king was not to have the power of life and death over any of his kinsmen unless he had the assent of the majority of the ten.

Such was the vast power which the god settled in the lost island

of Atlantis; and this he afterwards directed against our land for the following reasons, as tradition tells: For many generations, as long as the divine nature lasted in them, they were obedient to the laws, and well-affectionate towards the god, whose seed they were; for they possessed true and in every way great spirits, uniting gentleness with wisdom in the various chances of life, and in their intercourse with one another. They despised everything but virtue, caring little for their present state of life, and thinking lightly of the possession of gold and other property, which seemed only a burden to them; neither were they intoxicated by luxury; nor did wealth deprive them of their self-control; but they were sober, and saw clearly that all these goods are increased by virtue and friendship with one another, whereas by too great regard and respect for them, they are lost and friendship with them. By such reflections and by the continuance in them of a divine nature, the qualities which we have described grew and increased among them; but when the divine portion began to fade away, and became diluted too often and too much with the mortal admixture, and the human nature got the upper hand, they then, being unable to bear their fortune, behaved unseemly, and to him who had an eye to see grew visibly debased, for they were losing the fairest of their precious gifts; but to those who had no eye to see the true happiness, they appeared glorious and blessed at the very time when they were full of avarice and unrighteous power. Zeus, the god of gods, who rules according to law, and is able to see into such things, perceiving that an honorable race was in a woeful plight, and wanting to inflict punishment on them, that they might be chastened and improve, collected all the gods into their most holy habitation, which, being placed in the centre of the world, beholds all created things. And when he had called them together, he spake as follows...

And so ends the telling of Atlantis by Plato.

A Cataclysmic World

Plato claimed that it was the respected Greek statesmen named Solon who first wrote of the history of Atlantis. It is said that Solon had learned of the legend while in Egypt. Not only did the Egyptians have legends of a land of seven islands in the west that they called Amentet, but across the desert, the Carthage seafarers came home, from the west, with a similar story. The Englishman, Harold Wilkins, gave an interesting account of such a legend:

“It is also significant that Diodorus Siculus, the first-century B.C. historian who drew on archives in the old temples of Carthage [...] The Carthaginian mariners voyaging the Atlantic, after the destruction of Atlantis, tell us of Basilea, sister of Atlas, one of the Atlantean kings - a man not a god, as she was a woman and not a goddess - who married her brother Hyperion, the sun or Lucifer, in the fashion of the later ancient Egyptian Pharaohs, and bore him Helio (the sun) and Selene (the moon). Basilea's brothers of Atlas slew Hyperion and drowned the child Helio (the sun), lest Hyperion might take the throne of Atlantis. Maddened by these murders, Selene cast herself from the top of a mountain and perished, while Basilea lost her reason, and when her Atlantean subjects tried to restrain her, a frightful hurricane, with lightning and thunder, arose and she vanished. If we euhemerize these myths, we might say that what they import is that some cosmic body, whether or not Selene, the Moon, approached our own planet, the Earth, after the Sun (Helio) had vanished behind vast clouds into a night of blackness, and brought on an appalling cataclysm - the Great Deluge of the Old World myths and Genesis - in which Queen Basilea, symbolising the great island-continent of Atlantis, was seen no more of men.”

The Carthaginian legend is reminiscent of the Greek story of Phaeton. Jürgen Georg Ferdinand Spanuth elaborates on the legend in this description:

“The catastrophe would have happened with the passing of Halley's Comet, described by the Greeks in the legend of

Phaeton, son of the Sun God, Helios. Phaeton asked permission from his father to drive the Chariot of the Sun for a day. When the horses felt the reins were in the hands of a novice, they bolted and fell to earth. So that a Column of Fire devastated the world. The Nile dried up, fertile Libya became a desert, the remaining islands of Hyperborea were drowned. After fire came ice. Thanks to Zeus, who felt pity for the land and managed to divert the runaway chariot, which had destroyed Phaeton with its rays, the planet is saved. Phaeton falls into the North Sea where he is changed into Amber. His sisters, the Heliades, cry for him.”

The tears of his sisters who cry over Phaeton’s ‘golden amber’ demise and disappearance is reminiscent of lovely Freya, who cries tears of gold while she searches for her beloved Od-ur who had also disappeared. Phaeton’s sinking into the North Sea immediately brings to mind *The Oera Linda Book*. Favored by Herman Wirth and the Ahnenerbe, *The Oera Linda Book* was a recorded history by the Frisians who were under the patronage of Frya (Freya) and speaks of a great land which sank into the North Sea:

“During the whole summer the sun had been hid behind the clouds, as if unwilling to look upon the earth. There was perpetual calm, and the damp mist hung like a wet sail over the houses and the marshes. The air was heavy and oppressive, and in men’s hearts was neither joy nor cheerfulness. In the midst of this stillness the earth began to tremble as if she was dying. The mountains opened to vomit forth fire and flames. Some sank into the bosom of the earth, and in other places mountains rose out of the plain. Aldland, called by the seafaring people, Atland, disappeared, and the wild waves rose so high over hill and dale that everything was buried in the sea. Many people were swallowed up by the earth, and others who had escaped the fire perished in the water.

It was not only in Finda’s land that the earth vomited fire, but also in Twiskland (Germany). Whole forests were burned one after the other, and when the wind blew from that quarter our land was covered with ashes. Rivers changed their course, and at their mouths new islands were formed of sand and drift.

During three years this continued, but at length it ceased, and forests became visible. Many countries were submerged, and in other places land rose above the sea, and the wood was destroyed through the half of Twiskland (Germany). Troops of Finda's people came and settled in the empty places. Our dispersed people were exterminated or made slaves. Then watchfulness was doubly impressed upon us, and time taught us that union is force."

We find it compelling that on the other side of the Atlantic we find references to nearly the exact same name for a lost golden land. The Aztecs of America had records of such a place. Let us once again refer to Ignatius Donnelly and what he had reported to have discovered:

"The Aztecs also claimed to have come originally from Aztlan. (*Ibid.*, p. 321.) Their very name, Aztecs, was derived from Aztlan. (*Ibid.*, vol. ii., p. 125)...The 'Popul Vuh' tells us that after the migration from Aztlan three sons of the King of the Quiches, upon the death of their father, 'determined to go as their fathers had ordered to the East, on the shores of the sea whence their fathers had come, to receive the royalty, 'bidding adieu to their brothers and friends, and promising to return'... This Aztlan, this Atlantis, exercised dominion over the colonies in Central America, and furnished them with the essentials of civilization. How completely does this agree with the statement of Plato that the kings of Atlantis held dominion over parts of 'the great opposite continent!'"

We could continue presenting ancient legends and writings about the semi-divine Aryan giants of old for another hundred pages. We hope that the above will suffice. Yet, there is one more vital component that needs to be understood, which is, Hyperborea and Atlantis were never the same place.

That which has been named Hyperborea was the original Aryan homeland. Situated in the far North, it was 'the home of the Gods'. Hyperborea had a tropical climate, where the Sun had always shone (Apollo spent His time there), that became uninhabitable with the cataclysmic event that tilted the earth's

axis. From there, the ancient Aryans would first head south with their noble science and only then would they found places, such as, 'Atlantis'.

In his book, *Revolt Against the Modern World*, Julius Evola wrote of those early migrations:

“As far as the migration of the Northern primordial race is concerned, it is necessary to distinguish two great waves, the first moving from north to south, the second from west to east. Groups of Hyperboreans carrying the same spirit and same blood, and the same body of symbols, signs, and languages first reached North America and the northern regions of the Eurasian continent. Supposedly, tens of thousands of years later a second great migratory wave ventured as far as Central America, reaching a land situated in the Atlantic region that is now lost, thereby establishing a new center modeled after the polar regions. This land may have been that Atlantis described by Plato and Diodorus... These races supposedly corresponded to, among others, the Tuatha de Danaan, who came to Ireland from Avalon and who were led by Ogma Grianaineach, the hero with a 'sunny countenance', whose counterpart is the white and solar Quetzalcoatl, who came with his companions to America from the 'Land situated beyond the Waters'”.

This is so very pertinent in order to understand the complexity of things. It is the Hyperborean Spirit that builds and creates religion, science, and civilization – in one word: culture. It is the 'slaves of Atlantis' mentality that first distorts and then finally destroys culture and the whole struggle is in the blood – we must preserve our Aryan blood or everything is lost. It happened in Atlantis and it is happening right here and now. The children of mammon have presently warped truth to such an extent, that the only place we shall now find it is within, which has always been the best place to find it, anyways.

To be honest, the more ritual and ceremony becomes superstitious, the further we are from God. The Hero, that is, the man of Destiny, carries his religion within him - always. Our divine Ancestors were not pompous, superstitious beings. They did not believe in an order of the cosmos, they knew the order of

the cosmos and carried that truth within them wherever they went. Even Robert Charroux, who wrote of all sorts of kosher nonsense, realized that the Hyperborean Spirit is the creator of culture and is always assailed by the material darkness that cannot comprehend the Light. In his book, *One Hundred Thousand Years of Man’s Unknown History*, he wrote:

“Unfortunately, those who had the duty of keeping the ancient secrets alive did not always find initiates worthy of receiving them. Errors and distortions crept in. Unworthy initiates perverted the legacy into base sorcery, the kind of occultism that claims to obtain knowledge with the aid of the Devil. An inferior knowledge may have been propagated in continents and kingdoms that have since vanished as though punished by a divine curse.”

Nevertheless, here we are still reliving the same dramas, which is really the same story. For it does not matter how many ways this story has been retold by the Indo-European world, the conclusion is the same. The memory of a divine place and time that met with a tragic end.

A Bearer of Light, who is basically innocent, suffers a fall to earth. Thus, a Golden Age lost because of a natural destruction brought about by a spiritual catastrophe. No one can deny that a celestial body collided with the earth in pre-history. Therefore, tilting the earth to its present Axis, which is, the reason for our seasons.

The ancient Arcadians spoke of a land before our present moon accompanied the earth only 12,000 years ago. The legends of a time before this moon are numerous. They span from the natives in the west to the Egyptians in the east. Not only our Moon, but also the Morning Star, has many strange legends about its movement and variation. It was not considered just another star in the sky, but rather something unique in itself. Most ancient accounts identified the Morning Star as ‘a comet’, which came and took its place in peculiar orbit. Anyone who has ever watched the nightly procession of the Morning Star knows that it commands the skies. Both the Moon and Venus (Morning Star) along with Mars and the Sun played a major role in those

celestial events. Many believe that a blue blooded and almost transparent divine race (Hyperboreans) landed here from Venus and brought spiritual consciousness to earth.

Charroux puts forth many proofs of man's extraterrestrial origins and then claims Venus to be our ancestral homeland:

“What are we to think of the Agartha? Is it nothing but an occultist hallucination, or is it one of the depositories of truth bequeathed to us by Venusian exiles?

Venus now plays an important part in our visions of interplanetary travel, and from the earliest known times it has been involved in great mysteries...From Tiahuanaco, Glozel, India, Egypt, Asia Minor, etc., comes evidence that the secret of tradition can no longer be concealed. Classical science has failed to provide proof that man originated on earth. For untold thousands of years, tradition has persistently maintained the opposite, and this view is gaining new support everyday.”

These kind of attestations seem outlandish until one takes the time to research the ancient records, which insinuate these very things. Interesting is the account that a fellow named Steve Omar gave in, *Atlantis History of the Golden Ages*:

“Dr. George Hunt Williamson, who wrote and lectured about an ancient manuscript he found in a temple in the Andes, *wise Atlantians and Lemurians*, who predicted the ‘end’, escaped to ‘safety areas’ high in the Andes and Himalayan mountains, as well as underground inside mountains, while many others were rescued in saucer shaped spacecraft that took the survivors to Mars and Venus (to bases where they awaited to return to Earth to begin a new civilization).”

O, how true it is that nothing ever really dies, the spirit or energy only transforms. There are always survivors no matter how cataclysmic the event. The Romans left no stone atop another when they razed Jerusalem and yet there it stands.

‘Something’ landed, therefore, fracturing the earth in a way that Hyperborea became the other earth, existing side by side with our reality, but somehow separated by dimension. It is there

that the great and noble race of Paradise took refuge. Serrano explained it as such:

“The Vanir can not bear so much misfortune, gone into the Inner Earth through the Wound-Door of the Pole, moving to the Astral Earth, the Soul, to what still remains of more subtle matter in this world, to build the cities of Agartha and Shamballa. As well as the City of the Caesars in the legend of the South, only reached by the Caleuche with the Man to Come.”

The Vanir is a familiar name to anyone who has studied the Nordic Eddas. Again we find ourselves, face to face, with the flowing blonde haired Freya, who is of the Vanir. An ancient race - or gods - from whom the Aryans are descended. Amongst many of Her attributes, Freya is the Northern Goddess of love, which would coincide with Venus or the Morning Star.

What the 'slaves of Atlantis' have properly named 'alien' (for it is alien to them), the Aryan knows as his Ancestor and we are not speaking of 'reptilians'. The noble race of Gods, from which we descend, waged war against those creatures. Again, we are dealing with two completely different psyches. What they fear - we embrace. What they embrace - we shun.

What we are saying is that, *in their need*, the Third Reich had achieved their destiny by the aid of the race of Paradise. Those ancient Hyperboreans who never really left even though we cannot see them. Their bodies are in the other earth or sanctuary. Their spirits walk beside us. It was with their blessing that the Hitler loyalists produced the legendary Vimanas.

The reasonable question that any skeptic should be asking by now is, if these great beings, the giants of old that have been named Hyperboreans, had truly existed - surely there would be some sort of proof. Where is the evidence? Why haven't the archeologists, military, etc. discovered remnants of this race of Utopia? The answer is...*they have*.

‘The Giants of the Americas’

City of the Caesars

There are many tales of hidden civilizations of Aryan Giants within or about South America. The City of Caesars is by all accounts in the Patagonia. It is said to be the home of Giants in between Chile and Argentina. There are several legends of its existence. Our favorite story took place in 1540 when a ship sank in the straits of Magellan with supposedly no survivors. Twenty-three years later two of the sailors returned to Chile with an amazing tale of the City of the Caesars.

Another interesting story of an encounter with the Giants of Patagonia comes from none other than Ferdinand Magellen. The chronicler on his ship was a Knight Hospitaller by the name of Antonio Pigafetta. Pigafetta kept a record of events; in his journal he wrote:

“Leaving that place, we finally reached 49 and one-half degrees toward the Antarctic Pole. As it was winter, the ships entered a safe port to winter. We passed two months in that place without seeing anyone. One day we suddenly saw a naked man of giant stature on the shore of the port, dancing, singing, and throwing dust on his head. The captain general sent one of our men to the giant so that he might perform the same actions as a sign of peace. Having done that, the man led the giant to an islet into the presence of the captain-general. When the giant was in the captain-general's and our presence, he marveled greatly, and made signs with one finger raised upward, believing that we had come from the sky. He was so tall that we reached only to his waist, and he was well proportioned.”

Many have searched for the City of the Caesars, along with a host of other mythical destinations, such as, the mysterious white land of Gran Paititi, but usually to no avail because they are of another time and place. We are only left with the ruins to ponder, such as, in Bolivia where the remains of the famed Tiahuanacu stand near the mysterious Lake Titicaca.

Tiahuanacu

The more one looks into Tiahuanacu the stranger the evidence becomes. Tiahuanacu could very well be the oldest ruins in the known world. Nestled high in the Andes Mountains, no authority can explain whence they came. There are only two possible answers. They were built by those who landed in Vimanas or they were there before the Andes. The famous British explorer Colonel Fawcett claimed:

“These megalithic ruins of Tiahuanacu were never built on the Andes at all. They are part of a great city submerged ages ago in the Pacific Ocean. When the crust of the earth up heaved and created the great Andean Cordilleras, these ruins were elevated from the bed of the ocean to where you now see them.”

Around the year 1540, Cieza de Leon had reported:

“Some of the natives told me that all these marvels sprang from the ground in a single night. There are not such stones in any of the hills around.”

The Tiahuanacu complex is very similar to the ancient works on Easter (Ostara) Island. Easter Island is in the middle of the Pacific ocean and west of Tiahuanacu. We know that once a great civilization existed between the two locations. It wasn't the only civilization of Aryans of giant stature lost in the spiritual catastrophe called earth. Nevertheless, the Spirit of Hyperborea cannot be destroyed. The Incas of the area gave a wondrous account of the White God of Thule reappearing. They named Him Viracocha.

In 1600 Don Antonio de Herrera, Crown officer of the King of the Indies and Castile, reported as told to him by the Peruvians, the following story:

“There presently appeared in the middle of the day, when the sun came out on Lake Titicaca, in the Andes, a white man, of a great body and venerable presence, who was so powerful that he lowered the hills, increased the size of the valleys and drew

fountains from the rocks. They called him, for his great power, lord of all created things, and father of the sun: for he gave life to man and animals and by him notable benefits came to them. And, working these marvels, he went a long way towards the north, giving, on the road, an order of life to the nations, speaking with much loving benevolence, correcting them that they might be good and upright... And they built many temples.”

Viracocha was so revered by the Incas that still in Colonel Fawcett’s day they would chant *Vira Vira* in Hymns to the rising Sun. He has many names amongst the natives of South America. He is the Viking Ull of Father Jacques. Some claim these were different White Gods of the same order. Others say He is one and the same. It does not matter if He was one great Leader or several Hyperboreans. That which is important is He and His idea existed, this no one can deny. Their Pyramids testify to that fact. The British researcher Harold Wilkins made some good observations about such:

“The great Sun Temple of ancient Tiahuanacu was built on the top of a gigantic truncated pyramid, one more pointer towards the probable or possible fact that the ancestors of the ancient Egyptians of the Pharaohs came from some lost land far out in the Western Pacific. The astronomers of Tiahuanacu had all the elements of the modern telescope: reflectors and lenses!”

And just as the Arabs in Egypt had been dismantling the Pyramids long ago for the materials, so also have the local natives begun to quarry the ancient artifacts of Tiahuanacu. It is a comic tragedy, but everything does have its reasons. What they will find there is what few know. The ancient Pyramids are not Pyramids. They are Crosses or X’s (X does mark the spot) only half exposed. It is the same zigzag or stairway design that are found in countless locations. It is the Sig Rune. The sign or signal of an entrance to the passages. They are speaking to those who can listen.

Honestly, these secret lost cities and Temples were Outposts. There are many worlds in this world. The question is; which one do we serve or better yet which one do we deserve? In

some remote locations the guardians of the hidden entrances still existed when the Spaniards arrived, such as, the Cloud Warriors.

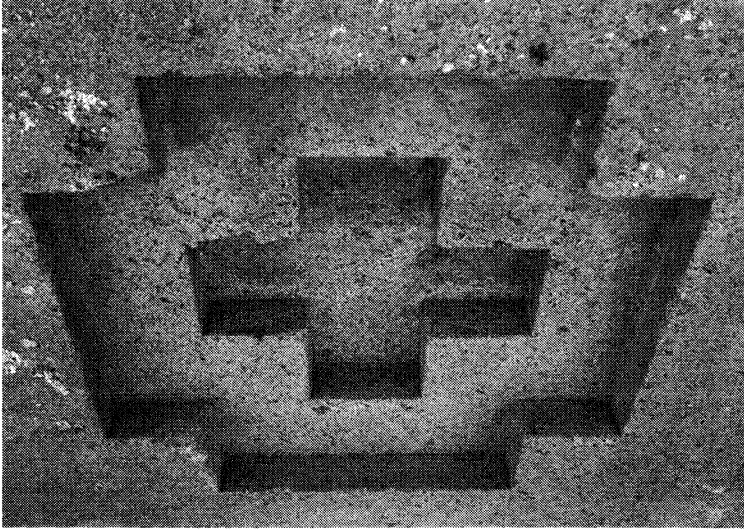

These crosses at Tiahuanacu are found at many places in the Americas.

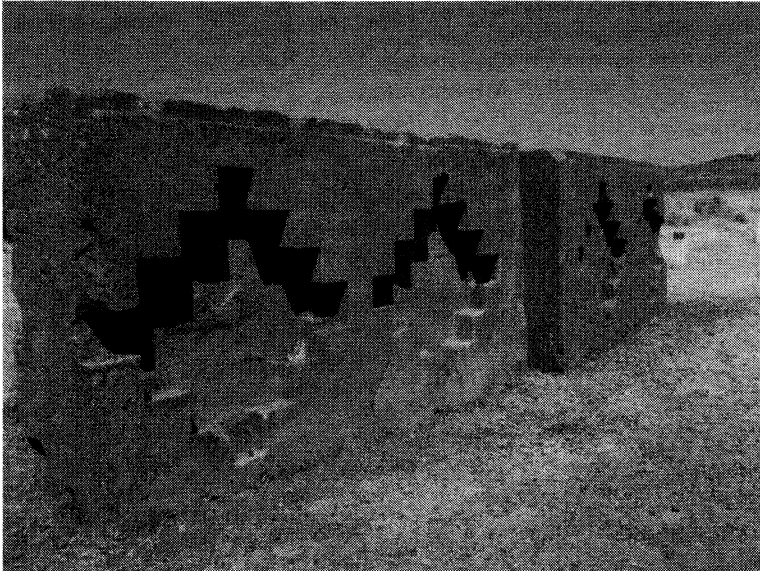

Prime example of the zigzag pyramid structures. 'As above, so below'.



The Gate of the sun. It is generally agreed that the carvings at the top represent a calendar, but what's interesting is there are only 290 days on it. This would correspond with the cycles of Venus, (always Venus) which spends 290 days as the Morning Star. It led to an area called the Kalassaya (place of standing stones) which seems to have been a celestial observatory. As we shall see, the Morning Star and the White Gods are inseparable.

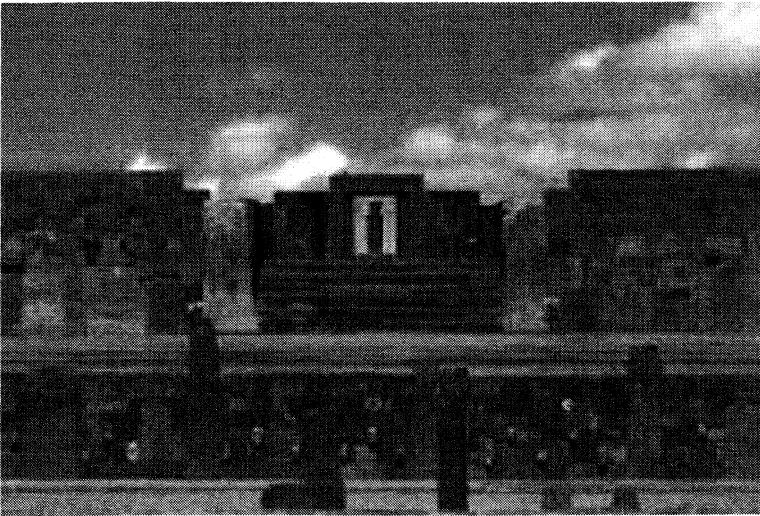

55 Club

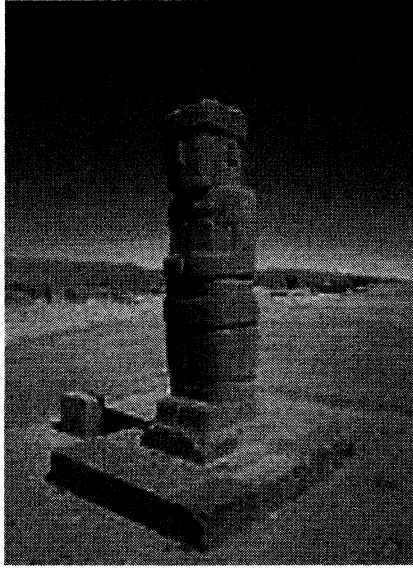

The similarities between the standing stone giants of Tiahuanacu and Easter Island are considerable.



As shown, the heads of Easter Island are not merely heads.

Warriors of the Cloud

"In ancient cities of South America, some of which may have been populated by over 50,000 people, were found the mummies of Caucasoid nobles buried in the bowels of ancient temples. As ruins continue to yield their secrets it now appears that many of the ancient pre-Columbian civilizations were sea-faring peoples with a long tradition of open-sea sailing. Rather than walking 10,000 miles from Mongolia to Chile, it now seems that the "first Americans" may have sailed first class. And where they came from will soon be firmly resolved by DNA testing. Peru, Chile, and Ecuador are all revealing long forgotten cities of ancient peoples classified as racially part of the Indo-European family of people. From Red headed mummies in pre-Inca graves in Peru to blond headed Toltek warrior priests in central Mexico, this is not the history of your father's generation." - Louis Beam

When the Conquistadors arrived in Peru, they found a most willing and able ally in the Chachapoyas. Spanish texts describe them as a very tall, white-skinned, blonde-haired people, who were ferocious fighters. The Chachapoyas are also known in legend as 'the white warriors of the clouds'.

The Chachapoyas had been fighting off an insurmountable number of Incas for centuries. They were legendary fighters. Outnumbered one hundred to one, they successfully repelled the Incas, who, were after their women. For as renowned as these white warriors were for their prowess and ability to battle, the beauty of their fair women may have even been more legendary. It is quite remarkable to think of how the Chachapoyas resisted a continent of enemies for so long. The arrival of the Spaniards saved the Cloud People from the same fate of countless others who had been a remnant of the old ones.

The Gran Villaya area of the Cloud People, located over 8,000 feet high in the Andes mountains, is today shrouded by overgrowth in the high tropical rain forest of northern Peru, but less than 1000 years ago it was still a grand metropolis of fortresses and farms that covered 100 square miles. Here follows reports of the Archeological discoveries:

“There are 10,000 stone structures, complex units of circular buildings. Stairways run up terraces for several hundred yards, and there are underground caverns and about 24,000 circular structures of cut limestone. Kirelap, a great elliptical fortress whose walls soar to 60 feet, and which is thought to have once reached 150 feet, defends Gran Villaya from the east. From the west, the city and its agricultural terraces are guarded by a chain of fortifications. Local myths trace the Chachapoya culture to the 10th century BC.”

And again we hear from that team of archeologists:

“The people there were architects, farmers, and engineers who built aqueducts, canals, bridges, and once were in contact with the seas. The archaeological discoveries of Gran Villaya have already located 43 lost cities high in the Andes. Researchers have found roads built from huge stones leading down to the Amazon. There are few stones in the jungle, so they were likely transported there.”

The old stone causeways are to be found everywhere in the world of prehistory. And they leave the ‘intellectuals’ with the same question that they still have not answered – how did they get there? Truly, there was nothing so primitive about our earlier ancestors, not even amongst those who ‘appeared’ to have been stranded in the high mountains of the cloud forests.

In the following photographs the researcher will notice striking similarities to other mysterious and inadequately explained locations of the ancient world. Similarities such as the stone walls and zigzag designs, which look identical to those found in Zimbabwe or the cliff dwelling abodes so reminiscent of the Anasazi in the North American southwest.

Could it be as Louis Beam proposes and that in the Warriors of the Clouds we finally have a face (a white face) to give to the builders of the ancient dwellings and mysteries? We believe so and furthermore state that the ‘Cloud People’ were direct descendants of the pre-Inca builders.

'Final Battalion'

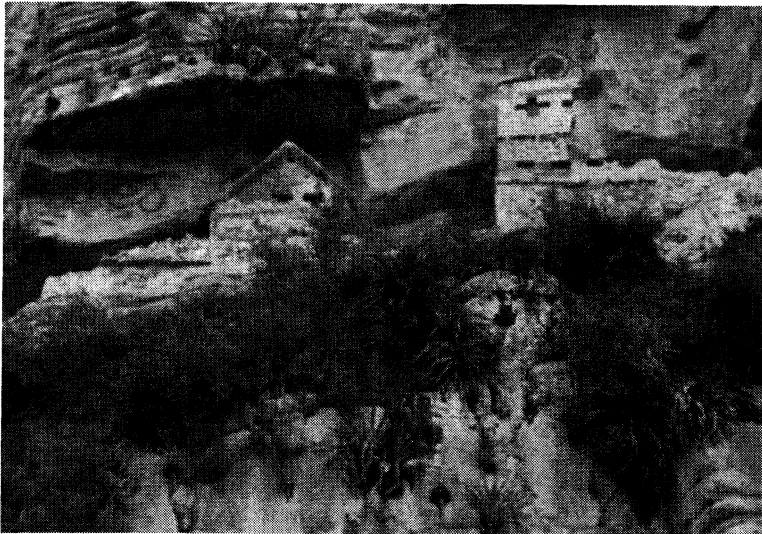
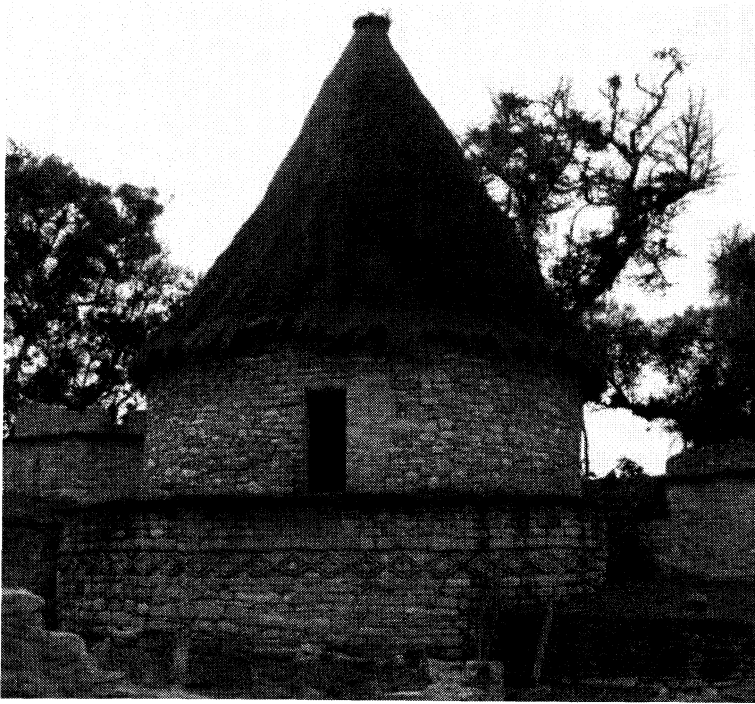

“The truth is that the ‘Incan Empire’ never really even existed. They were nothing but a bunch of half-naked savages squatting on land that was not and still is not theirs. A hand full of Spanish warriors walked right through them. The gold that ‘*Francisco Pizarro* took from them’ was not theirs anyway. He was sent there to requisition both the real estate and everything on it by their masters and the Inca royalty knew it, as they still do today.”

- Jack Heart

Northern Peru is home to many strange artifacts. There is a vast amount of evidence to the Aryan origins of the pre-Inca dynasties. Peru’s symbol for ‘luck’ is a fine example.



A Naylamp found by archeologists next to a pyramid in 2006

The Naylamp is the Peruvian national symbol. It is said to be a 'ceremonial knife' (an axe sized Naylamp was found in 1936) of the ruling class who were of gigantic stature. They are generally found in or near their tombs. Widely known as a symbol of 'good luck'.

It is not hard to see the resemblance of the Naylamp to an amulet of the mighty Thor's Hammer. This comparison is not far reaching, in the least, when we consider the words of the conqueror of the Incas. The Conquistador, Francisco Pizarro, tells us:

"The ruling class in the kingdom of Peru was fair-skinned with fair hair about the color of ripe wheat."

The Naylamp takes its name from the White God Naylamp, who arrived in the pre-history of Peru. Like Viracocha, Quetzalcoatl, etc., he came from a marvelous home, far away, across the 'oceans'. He would build the great city of Chan Chan, and then just as in the other stories, he left. Legend says that he turned into the 'birdman' and flew away.

In the ancient ruins of Chan Chan we come face to face with another startling discovery, there is no mistaking the Othala or Odal runes of Chan Chan, which tells us that Chan Chan was once a religious and ceremonial site.

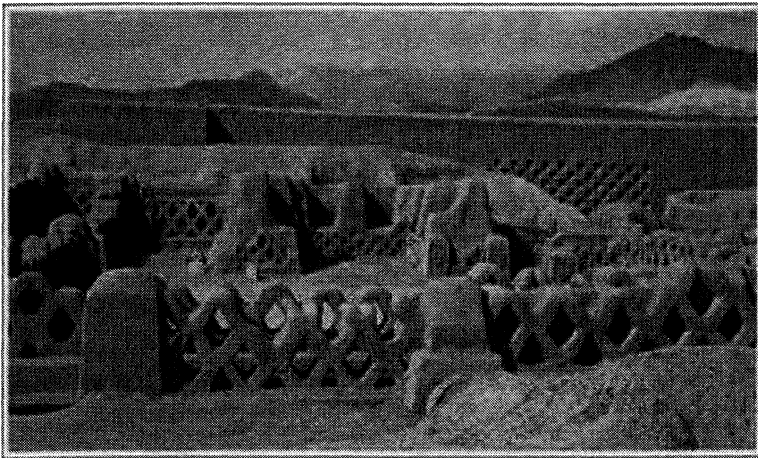

Another site that is believed to have been ceremonial is the mysterious Ollantaytambo. Nestled high in the mountains, the ancient complex is the home of gargantuan stones fitted so precise with one another that they rival Egypt. No one can explain how this came to be. The answer is in the craftsmanship.



From the ancient ruins of Ollantaytambo

Since the first reports of the Spanish up until the present day, there have been eyewitness accounts of ‘white Indians’ deep within the jungles of South America. We believe this is exactly what Adolf Hitler was alluding to in the cryptic explanation he gave Otto Skorzeny as to why he would never use the atomic bomb against the enemy:

“If I use it, then the others will also use it against us, since the knowledge of atomic fission will not belong to Germany alone. In the end, only some Amazonian tribes would save themselves.”

What information had been uncovered by the Germans for the Fuhrer to make such a statement? We know he was referring to a cataclysmic event that took place in pre-recorded history. An event that he would not be responsible for repeating.

Hy-Brasil

“Written legend says that people lived on this island [Hy Brasil] who considered everyone else on the mainland to be savages and primitives and apparently they had very advanced technology including levitation and advanced forms of sound healing, and they were ultimately forced to migrate away from their island ... When they got to Europe they actually became the builders of the stone circles and the standing stone-like megaliths and menhirs and so forth... Basically the people of Hy Brasil migrated to Europe and you can then trace them through the gods of Irish mythology, the gods of Celtic mythology and the gods of Norse mythology.” - David Wilcock

Hy or Royal Brasil is a name given in the Old Irish legends to a lost world or island west of Ireland. Very similar to the mystical Avalon, the island is shrouded in the mist. It is claimed that Hy-Brasil can only be seen once every seven years. The legend of Hy-Brasil, as Hermann Wirth has shown, came with the arrival of the Tuatha De Danaan, the ancient race of the Gods of the Celts who later returned to their home in the inner earth via the mounds of Ireland.

The myths of the Tuatha De Danaan give us some great insights into who the Aryan giants actually were. Theirs is the familiar story of a race of Gods who defeated a race of monstrous giants. In the introduction of this work we alluded to the ‘evil or dumb giants’. These man eating giants are not to be mistaken with the Gods who were gigantic in size compared to men, but smaller than the bad giants. The White Gods were well proportioned, superior beings, who gave man consciousness. They and their descendants were the mighty Heroes of old.

The legends of Ireland, a word derived from Aryan, tell us that the Tuatha De Danaan were of the race of Danu, the great Goddess and Mother of all. They settled in their new home and then, on the brink of war with the Fomor giants, appears the one and only Celtic Sun God, Lugh Lamfada (Lugh always shows up when you need Him). It is Lugh, also known as Lleu by the English, who defeats the King of the Fomors and thus begins a ‘Golden Age’ for the islands of the Celts.



Lugh Lamfada defeats the Fomor Balor

The mighty son of Lugh is probably the greatest hero in Irish history. Cuculainn is similar to Thor or Hercules. There are stories that say Cuculainn came to Ireland in a special ship when his homeland was destroyed. It is interesting that his name sounds very similar to the South American White god Kukulcan, who is also known as Votan of the Maya. Kukulcan is described as a bearded white man of 'very tall stature'. He was also said to have arrived in a ship, but our story must return to where the White Gods called home: Hy-Brasil.

Some have claimed that Hy-Brasil is none other than Brazil, or Brazil is some remnant of Atlantis. Deep in the jungles there is much evidence to support such a theory, that is, for those with the fortitude to traverse that wild.

The Austrian born geologist Friedrich Katzer, who shortly before the 20th century was the head of the Museu Paraense (Brazilian scientific center with over 4 million artifacts), made this keen observation:

"The old highlands of Brazil must once have extended eastwards into the Atlantic, and were largely built of materials derived from the destruction of a drowned Atlantic land."

There are countless stories of lost cities in Brazil that were marvelously constructed by White Giants and some have been found. The Lost City of gold supposedly named Z by the British explorer Colonel Fawcett is allegedly somewhere northwest of Cuiabá. It is said Z is what Fawcett was in search of when he and his companions disappeared. Perhaps the most famous of them all is the legendary El Dorado. The best accounts place it somewhere in the Parima Mountains at the northern border of Brazil. The Spanish historian Francisco Lopez de Gomara wrote:

"It is on an Island in a big salt lake. All the palace cutlery, for the tables are of pure gold and silver; copper and silver are used even for the most unimportant things. In the middle of the Island there was a temple dedicated to the Sun. Around this temple there were statues of gold representing giants. On the Island there are trees too of gold and silver. The statue of a Prince also completely covered in gold-dust."

Harold Wilkins in his book, *Mysteries of Ancient South America*, relates the following story:

"Another of these old Atlantean cities was visited by Fray Pedro Cieza de Leon, Spanish soldier-monk, who died in 1560. It was called Guamanaga, and is and was located on the great cordillera in lat. 12 degrees 59' S., long. 73 degrees 59' W. Cieza was tremendously impressed by the great edifices he saw there, all in ruins.

'Who built them?' he asked the natives.

'A bearded, white people, like you Spaniards,' said a cacique,

'They came to these parts many ages before the Incas began to reign and formed a settlement here.'

We shall never find all of the magnificent ruins that are lost in the Americas. Some are still being uncovered today, such as the lost city that was recently discovered in the southeastern

jungle of Mexico. Reported to have ancient walls and pyramids, it has been named Chactun.



2013 discovery of lost city (Chactun) on the Yucatan Peninsula

More interesting is the 2007 'Cloud People' discovery 500 miles north of Lima, Peru. The establishment has long contested that the 'Cloud People' were not in the area and yet they cannot deny that it was the Chachapoyas who built it. In short, with every find it becomes more difficult for them to deny that it was divine Aryans who constructed the wondrous ruins of the Americas. The Indians inherited them when the White Gods left.

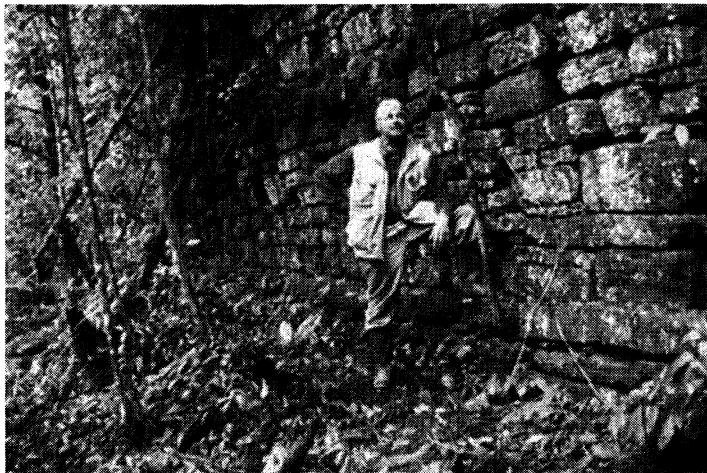

Researcher Keith Muscutt surveys a wall at the 'Warriors of the Cloud' archaeological site named the Penitentiary Ruin by the farmers who found it because of the massive size of the walls.

Before leaving the Amazon we would like to share a story written by Pierre Honore. Honore was a scientist who was said to have worked for a while with the Brazilian government. Although we strongly disagree with his conclusion, which is that the White Gods came from the Mediterranean, his adventure is, nonetheless, beautiful. Honore is not alone in this false conclusion. Time and again we find researchers and historians correlating their ancient American finds to the Egyptians, Cretens, Greeks, Sumerians and so on. They are correct in their comparisons, but since mainstream academia has no recorded history before the Egyptians or Sumerians, they are blind to the obvious. The truth is that the ancient Aryan God men sent emissaries across the world before and after the Spiritual catastrophe that destroyed their homelands. In other words, there is a common origin, but it is not from the far east. We will delve into this subject later in North America where the cover up has been immense. Nevertheless, Honore gives a wonderful account of his search for the White God Quetzalcoatl:

“Stones of The White God, one of them said. They offered to take me, and it would be four days rowing up the river, turn off into a big tributary and follow this two days, then it would be simplest to hack out a path so as to shorten our way. We came to terms and a canoe was loaded with everything we would need. And while mist was still over the harbor they rowed me up river...The two Indians addressed me as Viracocha, and one night as the one from the Apurimac pushed branches deeper into the fire he began to talk about the Great White God, the Ancient God of his country. He told of how once upon a time a white man with a beard had come to his people, from the east, and told how he had brought them all knowledge, all higher skills. He became the God of the Aymara people, the white and bright, the shining God, how he had gone away but that he had promised to return. For six evenings I sat by our camp fire and heard of the great deeds of this White God called Kon Tiki Illac Viracocha. On the seventh day we tied up the canoe in another creek and started on our march. The air was humid, and sultry, the sun blazed down but we could not see it in this green twilight. Mosquitoes got into my mouth, nose and ears, and thorns tore

my shirt, arms and face. As we cut our path, yard by yard, thru bushes and bamboo, and day after day we fought on for the Stones I was looking for. Finally we found a narrow path which Ramos has used, and in another two hours we had reached the bank of a broad river bed, and there lay the stones I was seeking, there they lay by the dozens, in the water and most were under the water.

I forgot the hardships I had been thru. I forgot thirst and hunger, and for hours I stood up to my belly in the mud of the bank and scrutinized the symbols on the stones, line for line, page for page, like a great picture book which lay open in front of me. Quite a number had their whole surface covered with a jumble of lines and patterns but most were sketches of fishes, birds, jaguars. Other stones showed boats, ships, boats with keels not known to the Indians of the Amazon. Among others the head of an ox with horns turned up which was most surprising because there were not cattle in America until the Spaniards came in 1500 plus A.D. Sometimes there were carvings of birds in flight and landing, there was even a rhinoceros, yet the rhinos never lived in the Amazon region. There were men represented here, the god heads with haloes, sometimes helmets of horns similar to those known from Crete, and from Egyptian Stelae and reliefs. The animals were so life like thus Masters were at work here. There is no other explanation, men from the old world must have once been here on the water way which once led to the White God's kingdom.”

Quetzalcoatl

Of any names of the White Gods, by far, most renown would certainly be Quetzalcoatl. It was He who led the Northmen's Dragon Longship across the waters to the Americas. The last remnants of Thule, Hyperborea was on the brink of disaster along with the rest of the pre-ice age world. The 'slaves of Atlantis' had corrupted that once great land beyond repair. Only the semi-divine Aryans who had remained faithful to the Hyperborean Mythos of the Hero could see clearly by that time. Quetzalcoatl may have very well of came from the fallen Atlantis, which would explain his total disdain for degeneracy. The Noble King prepared in the Americas for the time to come. There are many accounts of His legend from the Spanish which they had received from the Aztecs, Incas and so on.

In the beginning of the seventeenth century Fray Juan de Torquemada was named the chronologist of the Franciscan order. This famous missionary is probably our best source of collected traditions about Quetzalcoatl, which he had received from the natives of old Mexico. Torquemada wrote the book, *Monarquía Indiana* (Indian Monarchies). He gave us much of what the world knows about Quetzalcoatl:

"Twenty chiefs, led by the great Quetzalcoatl, arrived 'out of the blue', one day, from the north-west. They were men great in stature, excellent gold-and-silver smiths. When they landed at Panuco, Quetzalcoatl was at their head and they marched inland, under his direction. They built the splendid city of Tullan, with fine and beautiful houses, temples and palaces, all of the greatest magnificence...Quetzalcoatl, it is held for certain, was a being of upright character, elegant carriage and was white and blonde with a ruddy face and bearded. His beard was long. He was of benevolent disposition and learned, and of great personage...and wore a black robe sewn with little crosses of red color."

It does not take much imagination to recognize that He named Tullan in Honor of Thule. It is from Tullan that he ventured out in every direction raising the natives to consciousness wherever He 'wandered'. He had absolutely no

tolerance for nonsense. That being said, He was an extremely benevolent and just King. The legend of this White God has carried over to our day. The Toltecs and Aztec of Mexico called him Quetzalcoatl, the Incas called him Viracocha, to the Maya He was Kukulcan, the Chibchas called Him Bochia, the White Mantle of Light. In Peru He was Hyustus and to this day they will tell you that He was fair and had blue eyes. Fray Bernardino Shagun tells us:

“They could do practically anything, for nothing seemed too difficult for them, they cut the green stone, they melted gold, and all this came from Quetzalcoatl....arts and knowledge.”

His extraordinary mission caused dissention in the ranks. In the end, He left Tullan in disgust with the degeneracy of the ‘slaves of Atlantis’ that infiltrated even there. With the introduction of such things as bloody sacrifice and thoughtless miscegenation, the good King Quetzalcoatl left His home at Tullan. Alejandro Vega Ossorio stated:

“After some excesses in the exercise of power and after an important revolt, the white men of Chichen Itza were expelled by the Mayan people and came back to Tula. There, Quetzalcoatl moves to the Atlantic Ocean, ‘angry’ with his people to have mingled with the natives.”

Here is where things do become interesting, in His leaving, Quetzalcoatl promised He would one day return to scourge the ‘golem’ mentality from His Americas. As far as the natives were concerned he returned in the personage of Hernan Cortes. When Cortes and his Conquistadors arrived the natives revered them as the return of the White Gods. Torquemada tells us:

“He told Cortes that Quetzalcoatl was a great magician and necromancer, and reigned king of that land, and that, on leaving that country, he betook himself towards the sea, feigning that the sun god had called him to the other part of the sea on the eastern border; but he promised to return afterwards, with great power,

and avenge his wrongs and redeem his town from injuries and tyrannies.”

Cortez and his men were wearing the same kind of outfit as the Thulians of old. The Incas even recognized the Spanish Bishops with their miters as the High Priests of the new religion. Today, our children are taught that the Spanish were monsters to the good Indians. These are the one-sided tales of the powers that be who hate anything Aryan. A more accurate depiction was made by the director Mel Gibson in his movie ‘Apocalypto’. We are fortunate to have the words of Cortes on this matter. After his meeting with Montezuma, King of the Aztecs, Cortez wrote in his first letter, dated October 30, 1520 to the Holy Roman emperor and Spanish king, Charles V:

“It is now many days since our historians have informed us,’ said Montezuma, ‘that neither my ancestors, nor myself, nor any of my people, who now inhabit this country, are natives of it. We are strangers and came hither from very distant parts. They also tell us that a Lord, to whom all were vassals, brought our race to this land, and returned to his native place. That, after a long time, he came here again and found that those he had left were married to the women of the country, had large families, and built towns in which they dwelt. He wished to take them away, but they would not consent to accompany him, nor permit him to remain as their chief. Therefore, he went away. We have always been assured that his descendants would return to conquer our country, and reduce us again to obedience. You say you come from the part where the sun rises.”

It is worth noting that Montezuma makes it very clear that he is of Aryan descent. He did not recognize himself as one of the natives of the land with whom the entourage of Quetzalcoatl bred themselves into and therefore, making their greatness now only a memory. While the Aztecs have many recorded stories of their lost home named ‘Aztlán’ (Place of Whiteness), He would claim to be from Tullan, Tollan or Tula (Thule) and he was correct for this was the very reason he was King. His bloodline

could be traced back to the White Gods. He was a descendant of the Aryans who did not obey Quetzalcoatl .

The Spanish had more surprises to come. Legend said that Quetzalcoatl was the son of a Virgin. September 8th was the birthday of the White God's Mother. Any Catholic will be quick to recognize that this is also the day celebrated as Mother Mary's birth. The White God's birthday was celebrated on December 25th. On November 2nd, when Catholics visit the cemeteries, the Maya used to go to the graves of their dead. Here follows an interesting tale.

The Spanish were led to a temple of Viracocha. What they found is especially of interest for an Armanen. They entered and found a maze of 12 narrow passages going round the building. They made their way to the sanctuary, the center. There stood the figure of a man. It is said they all removed their helmets and made the Sign of the Cross. They knew Him from all the Churches and Chapels of Spain. It was of a man holding a chain in one hand and the other end of the chain was wrapped around the neck of a negro demon, which lay before his feet.

To the Spaniards this was a statue of St. Bartholomew. As word spread, a regular pilgrimage of Conquistadors would begin to go visit whom the Indians called the White God.

Let us not make the mistake of thinking of this only as a Christian theme. It is an Aryan theme and further proves that we knew the Christ long before His message was distorted in a dysfunctional, Judaic religion. Anywhere that we find the Hero ethic, that Noble thought and intention - we will find Him.

And we find Him in the greatest city of ancient Mexico, Teotihuacan (Home of the Gods). Legends tell of White giants, who at times have been identified with the Toltecs, had come in the forgotten past to raise its buildings to their towering height, but before we visit Teotihuacan – let us take a little closer look at the promise of the return of Quetzalcoatl.

The Return of Quetzalcoatl

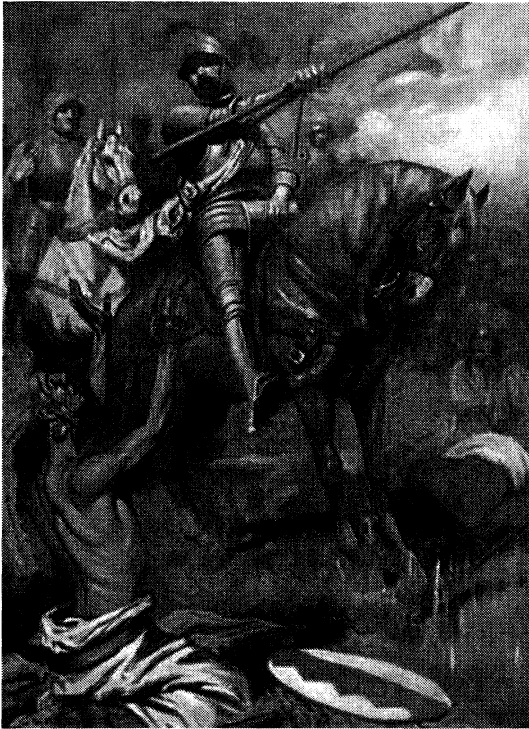

At this juncture, we are compelled to try setting the record straight about one of the great military campaigns of history. The misrepresentation, by falsehoods and downright lies, of Hernando Cortes and the Conquistadors is quite unjust. Who has not heard the horror tales of the wholesale slaughter committed by Cortes or the forced conversion and destruction of the 'innocent' Aztec Empire? What they do not teach us is that Cortes and his men faced armies of warriors which outnumbered the Conquistadors 100 to 1. They also forget to inform us that the insanely superstitious Aztecs were *sacrificing over one hundred victims a day* to their blood thirsty 'gods'.

Hernando - or 'Fernando', for that is the name he went by - Cortes was not the mad murderer that he has been portrayed as. The two great crimes that today's establishment will never forgive Cortes for are representing order and being an Aryan.

Although, the ‘universalism’ of Catholicism has not been healthy in any way, shape or form for the Aryan race as a whole - there is no mistaking that the Spaniards represented the forces of Light dispelling the darkness.

It is true that the Spaniards had cannons and muskets, but they could fall prey to thousands of spears and arrows while reloading (the horses were much more effective than any black powder). It is also true that they found willing allies in the subjugated natives who were not very happy with the Aztec ultimatum of pay a tribute or be sacrificed. And, by far, their greatest advantage was that the Indians knew that the White Gods had returned. But, all of this means very little when a few men on horseback are charging into a sea of armed warriors.

As previously mentioned, the populations of Central and South America were obsessed with an ancient promise of the return of Quetzalcoatl. They had always known that the day of reckoning would come and they knew that they deserved it. The very best of them were the descendants of the degenerated traitors who had usurped His Kingdom.

Native legends confirm again and again that they knew His return was near. Forewarnings such as an escalation of terrible, natural disasters and premonitions made by their priests were laying heavily upon the Aztecs. Then arrived 500 Conquistadors.

When Cortes and his men landed near what is now Vera Cruz, Mexico (True Cross), Montezuma immediately began sending messengers with gifts and it did not take long before some of his more lukewarm men began causing dissention through desertion and mutiny. Coupled with this was Montezuma’s finest gifts yet, pounds and pounds of gold with the *demand* that the Spanish leave the land of the Aztecs. Cortes finally responded.

In one courageous act, Cortes became his destiny – he ordered that their ships be destroyed! He ordered that his ships be destroyed with less than 500 men in a land with millions of hostile natives. He then would give an arousing speech appealing to the race and honor of the Conquistadors, which would end with the words ‘We shall conquer or We shall die’.

Montezuma’s nervous concern now changed to downright fear of the return of the White God. After consulting his priests

and the 'mirror', he would by all means possible try to prevent the Conquistadors' march to the Aztec capitol. The first major assault would be at Tabasco.

The area of Tabasco had over 30,000 warriors ready to end Cortes. When we say, 'end Cortes,' that is exactly what we mean, for the order and the shouts from the raging natives were 'kill the Captain'. The Indians were out to kill one man, or White God, they were there with orders to kill the agent of Quetzalcoatl. Undaunted, Cortes led the flank of a few brave horsemen who came up on the rear of the army. With spears and arrows covering the Captain's shining armor, he shone like the Sun and made them break, but not before the fierce, fighting Spaniards struck down more than one thousand warriors.



It was at this time that he was given the greatest gift, from Providence, that he would ever receive in America. To the victor goes the spoils – a beautiful ‘slave girl’ who was no mere native. La Dona Marina was a noble princess who, as a result of espionage and intrigue, had been sold into slavery. We must recall that what constituted the bloodlines of royalty in Mexico, as with everywhere else, was the direct lineage of Aryan blood or to be a descendant of the White Gods (strange, how the only folks who are really unaware of this are gullible, white people). By all accounts, her continence was mesmerizing to both the Indians and the Spaniards. She had the ability to bend any Indian to her will. The Conquistadors would name her ‘the Lady’. Teaching herself Spanish, practically overnight, she would become their sorely needed interpreter. With a pre-destined loyalty and devotion, she would ever remain at the side of the Hero who had redeemed her and save him from Indian deceit more than once. Next, would come the hardest fighting yet.

Marching on towards Montezuma, Cortes would encounter a great stone wall several miles long with only one narrow passage. Being sure of an ambush waiting on the other side, the men hesitated. It was Cortes, who took the lead and went through first. By a stroke of ‘luck’, the enemy was not ready. 400 Conquistadors patiently waited as 50,000 of the meanest fighters they would ever encounter hurriedly made ready.

The battle raged on for two days, the Spaniards took a defensive position and repelled every assault; the third attack would come at night. The enemy’s priests assured the native leaders that they could not beat the Spaniards during the day because they were the ‘children of the Sun’. Therefore, the final assault came by the cover of night, but Cortes was ready and routed them with his Cavalry of less than 15 horses. After two days and one night of fever pitched battle, the natives counted thousands of casualties, the Spanish had two.

Next, they would try treachery by sending an entourage with peace bearing gifts, but La Dona Marina warned Cortes that this was a trick and they were actually spies. Cortes responded by having the hands that bore the false gifts cut off and sent the spies back to their Chief with the message of a Hero:

'Final Battalion'

"Come by night, or come by day, you shall ever find me prepared for battle; and if after two days you do not appear, we will seek you out at your post!"

Alas, this is what legends are made of – the diminished army, of now only 40,000 warriors, asked for peace.

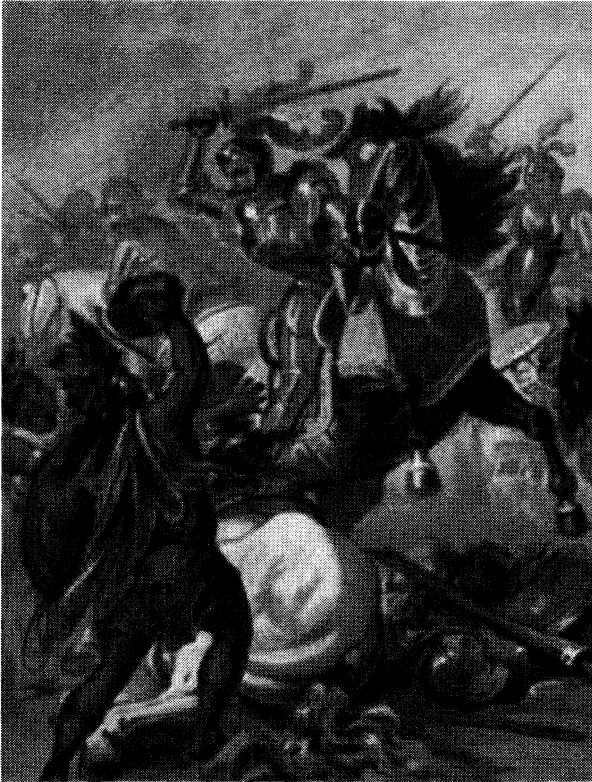

We are of the opinion that it had to be Montezuma and his advisors that gave the order for the change of tactics. Slyness would be their mode of operation from then on. After defeating 50,000 of the fiercest warriors (Tlascalans) that the Aztecs could muster, there would be no more open battles or standing armies to confront Cortes on his march to the King.

When the Spaniards entered the great and ancient city of Cholula they were welcomed and heralded as the return of the White Gods. The sacred city had been dedicated to Quetzalcoatl,

but it was treachery, for they had conspired to massacre the Spaniards when they were unsuspecting. When La Dona Marina heard of this from the townspeople she immediately informed Cortes who, wanting further evidence, had their priests brought before him. The priests confessed that Montezuma had sent the orders for an ambush and slaughter, because his priests and Gods had assured him that they would stop Cortes at Cholula.

Cortes quietly put his men into position. And as it became obvious that the surprise attack was imminent, Cortes declared in a loud voice 'How anxious are these traitors to feast upon our flesh...But God will disappoint them!' and gave the signal. What ensued was a bloodbath. The Conquistadors put the sword and musket to several thousand. Ironically, the last stand of the would be ambushers was at the top of Quetzalcoatl's temple. With the 'White God' in their hearts, amidst spears and arrows raining down, the Conquistadors valiantly charged up the pyramid and threw every last one of the offenders over the side as they reclaimed the temple of the All-Father.



Worth recalling is that in the swell of emotion, before the signal was given, Cortes declared the natives to be 'traitors'. To use that word at that time would have to mean that Cortes

believed he was in the service of the ‘White God’, who he, no doubt, saw in the figure of Christ. Much like Alexander the Great, it would seem that his Blood Memory had awakened. To be thousands of miles away from your homeland, and to perceive the natives of this distant land as ‘traitors’ certainly insinuates that the Archetype was present.

The shock and disgust that awaited the Conquistadors in the Aztec capitol city of Tenochtitlan is beyond words to describe. Being greeted with much pomp and ceremony at their arrival did not fool the Spaniards because of little things, such as, the head of a Conquistador kept as a trophy. Nevertheless, their real surprise came when Montezuma brought them to the Temple where the Aztec priests sacrificed over 1000 people a week. They would cut their hearts out and set them before their ‘Gods’. Rivers of blood flowed through cut channels that led to the demonic statues. These were the very same ‘Gods’ who had betrayed Quetzalcoatl. This was more than the Knights could bear, Cortes told Montezuma that his ‘Gods’ were devils and shortly after put Montezuma under house arrest. This was only the beginning of the conquest of Mexico, but it is where our story ends. The story of how less than 500 Knights marched upon an Empire of darkness.



Teotihuacan

The overwhelming amount of U.F.O. sightings in the area of present day Mexico City becomes even more interesting when one is aware that Mexico City has been built upon the ruins of the capitol of the Aztec Empire. What is more important is that the ancient 'Home of the Gods' or 'Birthplace of the Gods', which means 'Origin of the Gods' is only a few miles away. Teotihuacan is said to have been 'built by White Giants or White Gods who then went away' or disappeared.

The mysterious Teotihuacan was a great city situated in the Teotihuacan Valley, which is northeast of the ancient lake of Texcoco or the present-day site of Mexico City. In its time, it supported a population of hundreds of thousands of inhabitants. The Aztecs gave it the name of Teotihuacan – 'the place where the Gods were born'. Canals led out of the sacred center and into the city districts in each of the four directions. Perfectly parallel to the canals were streets for people on foot. All around these streets and canals there were lush, fragrant flower gardens.

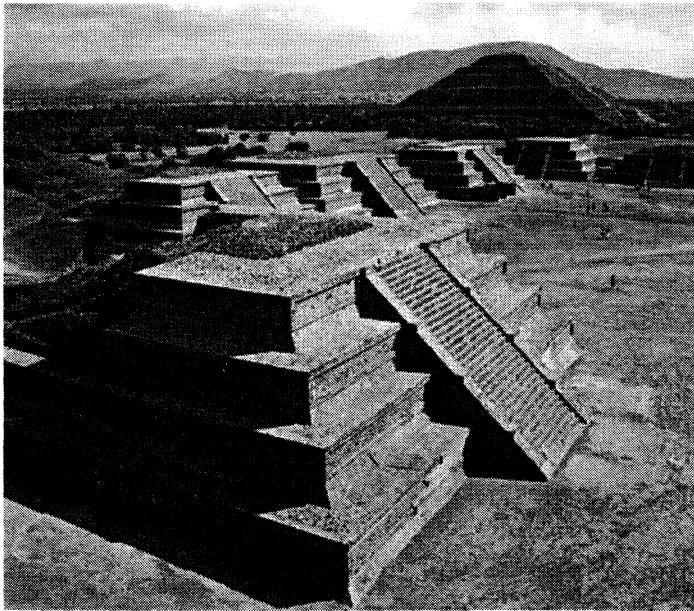

Teotihuacan

Today, it is claimed that this ancient city was part of the Toltec culture. In the language of the Aztecs Toltec means 'the highest craftsmen' and those who are called the Toltec were probably also the 'White Gods' who built 'the origin of the Gods'. The Aztecs made regular pilgrimages to this place they identified with Tollan, Tullan.

This city of marvel was the legendary Tula, named after their beloved Thule. Quetzalcoatl and the White Gods would make this their center, from which they would branch out in all directions in the same manner that the center and plazas were built. Authorities would like for us to accept other locations of impressive ruins as Tula or Tollan, but it is more disinformation. Quetzalcoatl's Tula is presently known as Teotihuacan.

It is stunning that the city of Teotihuacan was meticulously laid out on a grid which is offset 15.5° from the cardinal points. Its main avenue, the 'Way of the Dead,' (Milky way) runs from 15.5° east of north to 15.5° west of south, as the Pyramid of the Sun, which is directly oriented to a point 15.5° north of west. The last time the skies would have held this same position was over 23,000 years ago. 15.5° isn't much less than the tilt of the earth's axis. Another point that cannot be overlooked is the obvious correlation to Orion's Belt. The three pyramids of Teotihuacan line up exactly with Orion, just as the pyramids in Egypt, and so many other 'navel of the world' locations.

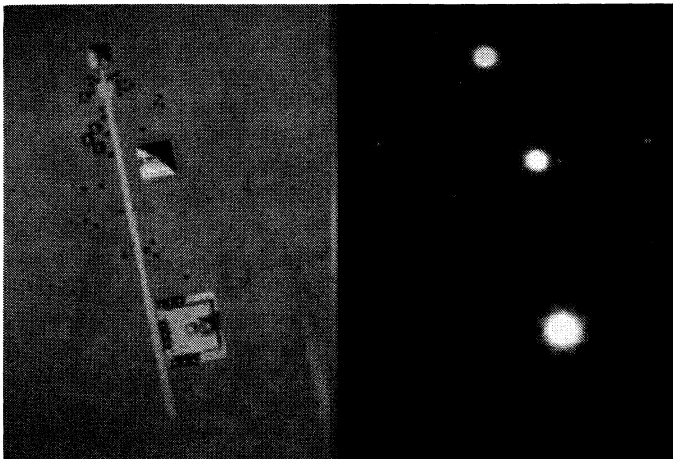

Teotihuacan

Belt of Orion

Our ancient ancestors believed that Orion was the center or navel of creation from whence the Gods originally came. According to Egyptian mythology, the Gods descended from the belt of Orion and Sirius, the 'Dog' star. The early Egyptians (pyramid builders) identified Orion with Osiris, for it was from this location in the cosmos that Osiris and His wife Isis came and were the progenitors of our race. It is fascinating that since then science has discovered star forming nebulas in the constellation of 'Orion'. Our divine ancestors of consciousness, who knew what is now hidden from us, were creating 'structural links'. The 'navels of the world' are replicas of the navel of creation (we shall delve more into this matter in the last chapter).

Archaeologists have discovered the entrance to an ancient system of tunnels in Teotihuacan. The passages seem to center around and under the Temple of Quetzalcoatl. The tunnels have been proven to be older than the city and undoubtedly connect with the massive caverns that the 'Pyramid of the Sun' was built upon. In 1971, it was discovered that leading from a natural cave below the pyramid, and running for about 110 ft. to the east, is a natural passageway. The passageway opens close under the center of the Pyramid into a 'four-leaved-clover' shape, each 'leaf' is about 60 feet in circumference and contains beautifully engraved slate discs and 'highly polished mirrors'.

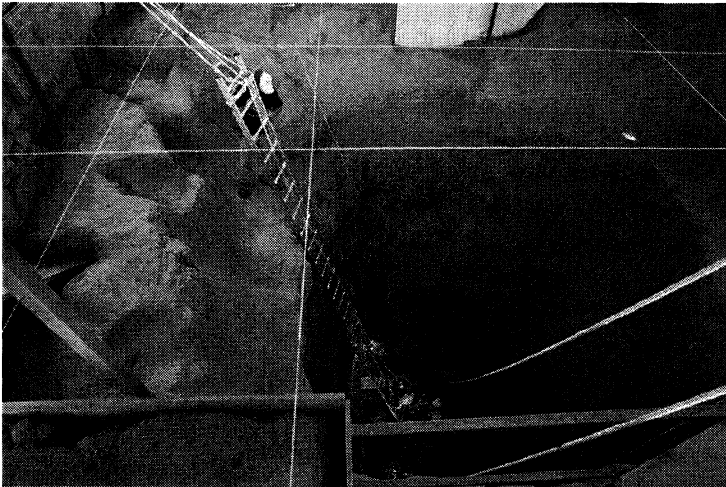

Excavation of the passages

We can assume that there was a great and spiritual significance for those who used this perfectly shaped clover leaf formed by nature. It is the 'place of emergence'. We can also assume that there was a 'horseshoe lake' somewhere nearby; it is sacred geometry at its finest.

Perhaps, the most stunning find of all would be the massive sheets of mica. Locals had been finding and selling mica at Teotihuacan for some time, but more recently, a 'Mica Temple' has been discovered on the site and has been left untouched. The temple sits around a patio about 300 ft. south of the west face of the Pyramid of the Sun. Directly under a floor paved with heavy rock slabs they found two massive sheets of mica. The sheets are 90 square feet in area and are laid one directly on top of the other, forming two layers. It is said that these sheets are as much as 12 inches thick. As it sits underneath a stone floor, its use was obviously not decorative but functional. Let us try to fathom this, two thick layers of a 9 by 10 ft. area of mica. It almost sounds like science fiction.

For those who may not know, mica is a substance used in highly advanced technologies. It is used in everything from electronics to heat shields and radiation. It acts as a moderator in nuclear reactions. Mica is stable when exposed to electricity and extreme temperatures. It has superior electrical properties and as a dielectric can support an electrostatic field while dissipating minimal energy in the form of heat. It is also used in capacitors that are ideal for high frequency and radio frequency. Mica is used in ballistic missiles (space) and a host of other elaborate functions to contemplate.

While there is much more information that can be presented on this subject, our purpose is to show evidences of the pre-ancient and semi-divine origins of places, such as, Teotihuacan.

Votan

In the lands of the Maya we will begin to close the circle. The world is well aware of Mayan prophecies, such as the calendar that ends in 2012, but what most do not know is that the White God Votan (Wotan) was the author of such prophecy.

Many scholars believe Votan and the Mayan God Kukulcan are one and the same for they were both White Gods, we prefer the name Votan. It is said that like the Sun, Votan came to this world from another dimension to illuminate the people. He came from where the Divine teachers await the right moment to return. In other words, He was a Hyperborean Avatar.

The ancient Mayan priests taught that Votan knew the 'tunnels of time' for He brought the wisdom of the stars with him. They also said that He taught them all the current sciences plus other sciences that are still unknown today. Interestingly, they claim He also taught the science of Kundalini.

It comes as no surprise that Votan was named the 'Grand Wizard' of time. As said, it was He who gave the Mayan Calendars. Ancient cosmic calendars were of great importance and made with great precision by the ancient Aryan Priests known as the Armanen. It is peculiar that the 'Mayan' calendars survived.

The disinformation that has been produced on Votan and the calendars is gargantuan. There is too much for us to decipher in this book alone, but we will touch on some key points.

As of late, 'historians' have tried to claim that the 7th century King K'inich Janaab' Pakal was Votan. They have confused this to the point of referring to 'Pakal I and Pakal II'. Ascending the throne at the age of twelve and expanding the arts in his kingdom for many decades, it would seem that K'inich Janaab' was a fascinating figure. It is true that Pakal's remains have been found at Tikal (Guatemala) in the majestic, lower tomb of the Pyramid of Inscriptions, but this is not the White God Votan.

Oral traditions collected by the Spaniards claim Votan was the "First man on the Yucatan whom God had sent to parcel out the land which is now known as America". He is Quetzalcoatl, the Hyperborean Ull Ipur of the Drakkur Longship.

This brings up another defamation by disinformation. The bizarre tale of the ‘reptilians’. The agents of the Old Testament would have you believe that the ancient Aryans were reptilians! This would be equivalent to calling the shining Sun the realm of darkness.

Edward Thompson gave us the true origin of ‘The Feathered Serpent’, in his groundbreaking work titled, *The People of the Serpent*:

“These traditions tell us, and carvings on ancient walls and stone columns sustain them, that unknown ages ago there appeared strange craft at the mouth of what is now known as the Panuco River in the State of Vera Cruz. The sides of these vessels shone like the scales of serpent’ skins, and to the simple natives who saw them approaching they appeared to be great serpents coming swiftly toward them. In these craft were light-skinned beings, and some of the traditions have it that they were tall of stature and blue-eyed. They were clad in strange garments and wore about their foreheads emblems like entwined serpents. The wondering natives who met them at the shore saw the manner of their coming with the symbol of the Sacred Serpent, which they worshipped, on their brows, and knew the strangers to be their gods come down from their home in the sun to teach and guide them.”

The Viking Longship has long been proven to be the culprit. Thompson also mentions that the natives worshipped the serpent before the ‘White Gods’ arrived. Therefore, for the Indians it was a great compliment to identify these strange beings with the serpent, which to them meant Godly and wise. Also, there are the ancient legends of Venus arriving in the region as a fiery comet with a tail. Some believe this to be the origin of the serpent in legend. Nevertheless, the naïve are as easily found today as any ‘simple native’ of the past. So, it is not hard to understand how the calendars have been so compromised.

In short, the calendars are based on the cycles of creation, which is true time or Ur time. A complete cycle is 26,000 years or one ‘turn of the wheel’ of the constellations. The Armanen calendars, no matter how they reach their conclusion, interpret

Tyr's circle (some identify with the Black Sun), which is the Zodiac ever rotating around the North (Pole) star. This is not horoscope astrology. It is the Aryan science of our position in the cosmos. Incidentally, this is also the origin of the Runes. They were carved from the sky. When Wotan/Votan hung on the Tree in self sacrifice to retrieve the Runes. It is said that *'He fell back from that Tree again.'*

The Mayan calendar, the 'long count' calendar is what most refer to them as today, is a remarkable system. It can accurately keep the cycles of time indefinitely. Votan showed how to mark important events. Pyramids were built accordingly. The calendar of Venus was also taken very seriously. Votan marked 2012 (or about) as a time of significant change. This coincides with earth entering into the age of Aquarius. In truth, it is the pinpointing of a change in the earth's vibration. And the more the enemies of a higher consciousness try to thwart these inevitable changes the harder it shall fall upon them. The memory and realization of our ancestral legacy cannot be stopped and this is why we see the powers that be almost in a state of panic. They know that their time is short.



The Tikal complex - where the 'Pyramid of Inscriptions' is located.

City of the Sun

When leaving the Yucatan Peninsula of the Mayan, sailing north across the warm waters of the Gulf of Mexico, eventually we would make our way around the Grand Isle and enter into Baratia (the haven of the notorious pirate and national Hero Jean Lafitte) and the Bayous of Louisiana. Protruding out of the water there are ancient Shell mounds scattered throughout the swamps that no one seems to notice or care to discuss. We know that Lafitte used one as his marketplace a little south of New Orleans. It was named ‘the Temple Mound’. To continue in our northern direction we must float up the mighty Mississippi. Making our way to the northern area of the state of Louisiana we pass the magnificent Eagle Mound at the astronomically oriented Poverty Point complex. Here at the Eagle mound, they do not like to talk about how the two outer aisles between the mounds correlate to the summer and winter solstice or how there is no erosion from rain within the mounds as they were constructed (how long could it go without rain in Louisiana, a month or maybe two?). The establishment’s lacking theories are not worth reproducing in this book. They do, at least, admit that the mounds are over 5,000 years old. Travelling further north we pass the great Emerald Mound and its subterranean tunnels outside of Natchez, Mississippi. As we inch ever northward we will come to the great confluence where the Ohio and Mississippi rivers meet like two brothers. This confluence marks the center of what is known as ‘Little Egypt’ (we will return to the ‘Little Egypt’ area soon enough). Further working our way up the Mississippi we eventually arrive at the heart of the United States, also known as the American bottoms. Eight miles east of St. Louis, Missouri, in the Illinois flatlands stands one of the largest step pyramids in the world. The ancient Pyramid has been named Monk’s Mound because of those same white robed monks from the quest of the Holy Graal, the Cistercian Order, who once resided there. John Van Tramp wrote of his visit in 1858:

“What a series of unanswerable inquiries succeed. When was this stupendous earth-heap reared up from the plain? By what race of beings was the vast undertaking accomplished? What

was its purpose? What changes in its form and magnitude have taken place? As we reflect, we anxiously look around us for some tradition, some time-stained chronicle, some age-worn record, but our research is hopeless. The race of aborigines can tell nothing of these tumuli. To them, as to us, they are veiled in mystery. The simple Indian stood before this venerable earth-heap, and gazed, and wondered, and turned away.”

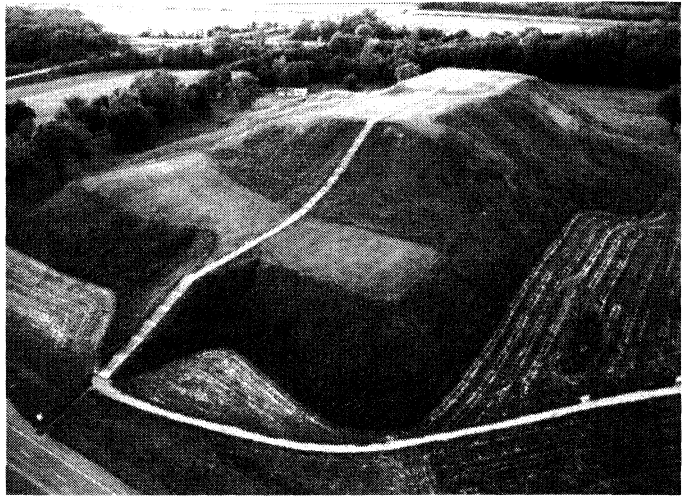

Monk's Mound of Cahokia

The cover up in the Mississippi Valley is immense. The establishment of Old Testament proponents would love for us to believe that Indians with bow, arrow and baskets built the megalithic earth pyramids of America. They would prefer that the masses never ask the many obvious questions that have not been answered. Nevertheless, some interesting information has managed to surface from time to time.

- 1) Relics of the Birdman of Manu-Tara have been unearthed at Cahokia. Serrano teaches that the Manu-Tara Initiation of the highest degree is of definite Hyperborean origin.
- 2) There is a large cement structure inside of Monks Mound.
- 3) Cahokia was named the City of the Sun and this Temple of the Sun oversaw a vast population of what is now Saint Louis.
- 4) There are still legends that Cahokia had been built by Giants.

MOUND GIANTS IN INDIANA SAID TO ANTEDATE INDIAN

SOUTH BEND, Ind.—Eight skeletons, one of them clad in copper armor, and a hoard of rare war weapons and bits of personal adornment have been found in a mysterious mound on the farm of Grove Vosburg, near Walkerton.

Vosburg, a 70-year-old farmer, had long desired to know the secret of the mound, which according to local tradition dates back hundreds of years. Secretly excavating the pile of earth he came upon a strange burial place.

GIANT SKELETONS

The eight skeletons lay in circular formation, arranged like the spokes of a wheel, with skulls together. Copper breastplates, bands and other bits of armor adorned the skeleton of one man, who apparently had been of giant stature.

THURSDAY, AUGUST 13, 1914.

RACE OF GIANTS ONCE INHABITED THIS PENINSULA

**MOUNDS NEAR SEMINOLE
BRIDGE GIVE UP BONES
OF MAMMOTH PEOPLE.**

**MUST HAVE BEEN
NINE FEET TALL**

Trace of Giants Found in Desert

LOS ANGELES, Aug. 4 (AP).—A retired Ohio doctor has discovered relics of an ancient civilization, whose men were 8 or 9 feet tall, in the Colorado desert near the Arizona-Nevada-California line, an associate said today.

Howard E. Hill, of Los Angeles, speaking before the Transportation Club, disclosed that several well-preserved mummies were taken yesterday from caverns in an area roughly 100 miles square, extending through much of southern Nevada from Death Valley, Calif., across the Colorado River into Arizona.

Hill said the discoverer is Dr. F. Bruce Russell, retired Cincinnati physician, who stumbled on the first of several tunnels in 1921, soon after coming West and deciding to try mining for his health.

STRANGE SKELETONS FOUND.

Indications That Tribe Hitherto Unknown Once Lived in Wisconsin.

Special to The New York Times.

MADISON, Wis., May 3.—The discovery of several skeletons of human beings while excavating a mound at Lake Delavan indicates that a heretofore unknown race of men once inhabited Southern Wisconsin. Information of the discovery was brought to Madison to-day by Maurice Morrissey, of Delavan, who came here to attend a meeting of the Republican State Central committee. Curator Charles E. Brown of the State Historical Museum will investigate the discoveries within a few days.

Upon opening one large mound at Lake Lawn farm, eighteen skeletons were discovered by the Phillips Brothers.

GIANTS' SKELETONS IN A CAVE.

Interesting Discovery by a Mexican Sheep Herder in Minnesota.

St. Paul, Minn., June 16.—Jose Herann-da, a Mexican sheep herder in the sm-

WISCONSIN MOUND OPENED.

Skeleton Found of a Man Over Nine Feet High with an Enormous Skull.

MAPLE CREEK, Wis., Dec. 19.—One of the three recently discovered mounds in this town has been opened. In it was found the skeleton of a man of gigantic size. The bones measured from head to foot over nine feet and were in a fair state of preservation. The skull was as large as a half bushel measure. Some finely tempered rods of copper and other relics were lying near the bones.

The mound from which these relics were taken is ten feet high and thirty feet long, and varies from six to eight feet in width.

The two mounds of lesser size will be excavated soon.

BONES OF PRE- HISTORIC GIANTS

**Relics of By-gone Race May
be Exhibited at
Jamestown.**

GIANT SKELETON

**Found in Bed of Sand in Northwest-
ern Ohio—Man Was Eight
Feet High.**

**Bowling Green, O., Aug. 14—While
excavating for sand for building on**

SKELETONS OF GIANTS IN ALASKA

Ancient Cemetery
Uncovered in the
Atlin Gold
District.

GIANT SKELETONS FOUND ON COAST

LOS ANGELES, Cal., July 12.—William Derbyshire and Jack Stoneberger, of Chicago, and Robert Derbyshire, of Santa Monica, contractors, have unearthed the skeleton of a gigantic prehistoric man at Santa Monica beach. The skeleton was over nine feet in height. Hard work uncovered thirteen more similar skeletons.

Georgia's Sand-Dunes Yield Startling Proof of Prehistoric Race of Giants

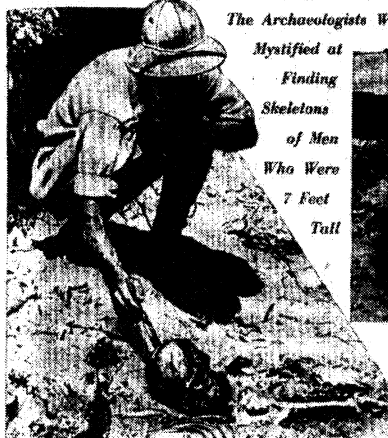

*The Archaeologists Were
Mystified at
Finding
Skeletons
of Men
Who Were
7 Feet
Tall*



Largest Skull Ever Recorded Is Discovered By Archeologist in Stafford County, Virginia

A primitive Algonquin Indian, who hunted and fished along the Potomac 300 years ago and who may have been a friend of the Princess Pocahontas, probably was the brainiest man the world has ever seen.

The skull of this man, which has capacity for brain capacity not skull previously recorded, was found in Stafford County, Va., by Forensic Judge W. J. Graham, of the United States Court of Customs and Patent Appeals, a prominent amateur archeologist, he announced his discovery yesterday. Judge Graham found the skull about two weeks ago. It was in several pieces and he sent it, as he has his other archeological finds, to the Smithsonian Institution. There it was assembled and

officials were astounded to find that it exceeds in brain capacity any skull on record.

Judge Graham said when he saw the skull after its assembling he was astounded. "It looked almost as big as a watermelon," he said. Its owner would have a hat size well over eight, he estimated.

Examination of the skull shows that it was healthy and not an abnormality, Judge Graham said. The skeleton of the mental giant was found, but it has not yet been assembled and measured, so the scientists do not know whether the bearer of the skull was also a man of tremendous stature.

Of all the 12,000 skulls of all races of people at the Smithsonian only one approaches the capacity of Judge Graham's discovery. That is

the skull of a prehistoric American found on a lonely Alouatta Island by Dr. Alex Hrdlicka. It has a brain capacity of 2,000 cubic centimeters.

The skull discovered by Judge Graham has a capacity of 2,260 cubic centimeters. The man who possessed it would be a mental giant when compared with most people today, who have only 800 to 900 cubic centimeters of brain power.

Although intelligence is said to be in part dependent upon the amount of blood reaching the brain, large brain size is also needed for great mental powers, scientists say. They point to two great men who are among those

Continued on Page 2, Column 2.

SAN ANTONIO EXPRESS

Beach Giant's Skull Unearthed By WPA Workers Near Victoria

Believed to Be Largest Ever Found in
World; Normal Head Also Found

That Texas "had a giant on the beach" in the long ago appears probable from the large skull recently unearthed in a mound in Victoria County, believed to be the largest human skull ever found in the United States and possibly in the world.

Twice the size of the skull of normal man, the fragments were dug up by W. Durfee, archaeologist, who is excavating the mound in Victoria County under a WPA project sponsored by the University of Texas. In the same mound and at the same level, a normal sized skull was found. The pieces taken from the mound were reconstructed in the WPA laboratory under supervision of physical anthropologist.

case of gigantism. Several large human body bones also have been unearthed at the site.

Marcus B. Gutsstein, physical anthropologist employed on the WPA project, formerly was an aide of Ales Hrdlicka, curator of the National Museum of Physical Anthropology.

Finds made through excavations in Texas are beginning to give weight to the theory that

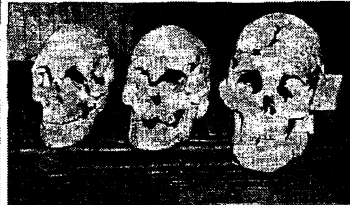

GIANT SKULL—Believed to be possibly the largest found in the world, the human skull shown on the right; was recently unearthed in Victoria County by Texas University anthropologists. The other two are of normal size.

DUG UP GIANT SKELETON.

Bones Thought to Be Those of Prehistoric Man.

KANSAS CITY, March 18.—While dig-

Skeletons of Stone Age Men Are Dug Up in Connecticut

Prehistoric Inhabitants of Nutmeg State Were Flat- Heads of Great Strength and Huge Teeth.

BRIDGEPORT, Conn., Aug. 19.—Two complete skeletons, believed to

It is really quite fascinating how so much overwhelming evidence means absolutely nothing to the establishment. When visiting a mound museum today, the staff simply insist that these ancient wonders were constructed by Indians. The thousands of Aryan Giant artifacts that have been found are simply tucked away and not spoken of. The deception by the 'slaves of Atlantis' have made our Ancestor's legacy all but forgotten.

If we were to layout North America like a flat piece of paper that had a rise wherever a mound is located it would read like a letter in Braille. By the farmer's plow and in the name of progress, probably half of the mounds have been destroyed and still there are that many. St. Louis is a good example.

As previously mentioned, the 'City of the Sun' was made up of a large area. St. Louis was originally nicknamed 'Mounds city' because there were more mounds than hills. Several thousand years ago, some of the greatest work in the history of civilization was accomplished in the St. Louis area. There are old maps that show countless mound clusters that simply do not exist today. For instance, 'The Big Mound' in old North St. Louis was over 150 feet long. For the sake of progress, 'The Big Mound' along with its history and secrets, were leveled to the ground.

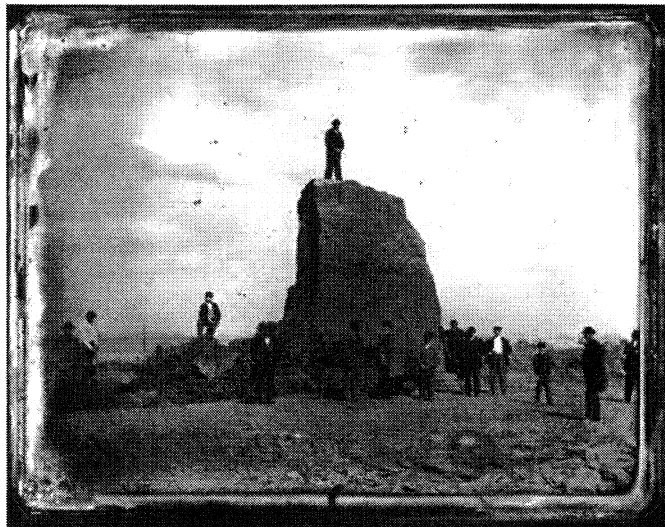

The destruction of 'The Big Mound' in 1869.

The Lost Race

Luckily, we are fortunate enough to still have a few of the early investigations in writing. The first few generations of European pioneers never believed that the great mounds were constructed by the natives. We have already alluded to the early settlers asking of the Indians from whence the earthworks came. The Indians could only answer that they were built by giants long ago. They would stare in wonder just as the Europeans. It was the common belief of the white man and the native that they had been created by a 'lost race'. The theories were numerous; lost tribes of Israel (Aztecs), Atlantis, Danes, Brahmans, Vikings, Celts, Egyptians and so on.

We are not saying that the Indians didn't use the mounds. On the contrary, we know that they inherited the earthworks and made much use of them and just as the Arabs of Egypt, they would even try their hand at reproducing the pyramids in simulation of what they had been shown by the remnant of a great race, who were still in North America when they first arrived. And this was common knowledge only 200 years ago.

One of the most well read books, of its time, pertaining to the subject of the ancient mound builders was published, in 1833, by Josiah Priest. Priest had been personally excavating the mounds for several years. He made some very interesting discoveries and wrote of them in *'American Antiquities and Discoveries of the West'*. Priest was a learned man and one of the first to document the 'Ding' (Thing), of the Nordic people, as a global phenomenon. He writes:

"Pennsylvania, abounds with monuments of antiquity. A fortified camp, of a very complete and curious kind, on the ramparts of which is timber of five feet in diameter, stands near the town of Brownville. This camp contains about thirteen acres, enclosed in a circle, the elevation of which is seven feet above the adjoining ground; this was a Herculean work. Within the circle a pentagon is accurately described; having its sides four feet high, and its angles uniformly three feet from the outside of the circle, thus leaving an unbroken communication all around. A pentagon is a figure, having five angles or sides. Each side of

the pentagon has a postern or small gateway, opening into the passage between it and the circle; but the circle itself has only one grand gateway outward. Exactly in the centre stands a mound about thirty feet high, supposed to have been a place or lookout. At a small distance from this place, was found a stone, eight feet by five, on which was accurately engraved a representation of the whole work, with the mound in the centre; whereon was the likeness of a human head, which signified that the chief who presided there lay buried beneath it. The engraving on this stone, is evidence of the knowledge of stone cutting, as it was executed with a considerable degree of accuracy.

On comparing the description of this circular monument with a description of works of a similar character, found in Denmark, Sweden and Iceland, the conclusion is drawn, that at some era of time the authors of this kind of monumental works, in either of those countries have been the same.

‘They are called *Domh-rings*, by the Danes; that is, literally, doom-ring, or, *circle of judgment*; being the solemn place where courts were held.’ The celebrated *Stonehenge*, in England, is built after the same fashion; that is, in a circle, and is of Belgic origin...The Druidic temples in Europe were numerous, and some of them immense, especially one in the isle of Lewis. In these the gods Odin, Thor, Freyga, and other Gothic deities, were adored; all such structures were enclosed in circles, some greater and some less, according to their importance, or the numbers of those who supported them. These are of the first order of antiquities found in Europe; or, in other words, the eldest, and go back very far toward the flood, for their commencement.”

If only he could have perceived his own words in the last sentence of his statement, then he would not have fallen into the trap that so many get lost in.

The first conclusion most Christians fall victim to, is that, these ancient wonders are evidence of earlier migrations of cultures that they are already familiar with. Of course, the Vikings, Celts, Romans, etc. traversed the ‘New World’ long before Columbus, but that is not the case with the ancient ruins in Pennsylvania. The Althing of the Northmen is of Hyperborean origin. It is a divine science that most today cannot comprehend.

Priest goes on to later report the excavation of the remains of a large skeleton by his own two hands:

“The whole was affixed in a thin layer of sand, fitted together with great precision, and covered a piece of bark in great decay, whose removal exposed what I was fully prepared to discover from all previous indications, the remains of a human skeleton, which was of an uncommon magnitude, being seven feet in length. With the skeleton was found, first, an earthen vessel, or urn, in which were several bones, and some white sediment. The urn appeared to be made of sand and flint vitrified, and rung, when struck, like glass, and held about two gallons, had a top or cover of the same material, and resisted fire as completely as iron or brass. Second; a stone axe, with a groove round the pole, by which it had been fastened with a withe to the handle. Third; twenty four arrow points, made of flint and bone, and lying in a position which showed they had belonged to a quiver. Fourth; a quantity of beads, but not of glass, round, oval, and square; colored green, black, white, blue and yellow. Fifth; a very large conch shell, decomposed into a substance like chalk; this shell was fourteen inches long, and twenty-three in circumference. The Hindoo priests, at the present time, use this shell as sacred. It is blown to announce the celebration of religious festivals. Sixth; under a heap of dust and tenuous shreds of feathered cloth and hair, a parcel of *brass* rings, cut out of a solid piece of metal, and in such a manner, that the rings were suspended from each other, without the aid of solder or any other visible agency whatever. Each ring was three inches in diameter, and the bar of the rings an half inch thick, and were square; a variety of characters were deeply engraved on the sides of the rings, resembling the Chinese characters.”

All evidence points to those 'Chinese characters' being of Runic origin. Again we witness his comparisons, this time to the Aryans of India. In a sense, he is correct, but correct only in the fact that the Northmen and the Aryans of the Vedas have a common origin. It is important that we expose the fallacy of the theory of an earlier migration of a peoples we are familiar with, because the enemy uses this to their advantage. We are not

denying that these migrations took place, but those seafarers were not the 'mound builders'.

When the 'slaves of Atlantis' cannot deny the origin of artifacts and remains (which happens frequently), they will grudgingly admit that there were probably earlier explorers. According to their many disinformation agents, North America was visited and colonized by Vikings, Celts, Romans, Egyptians, Phoenicians, Knights Templar, Brahmans, lost tribes of Israel, etc. If this were the case, that a multitude of different nations colonized North America such a short time ago, the evidence would be immense and no one would have ever heard of Christopher Columbus or Leif Erikson.

All of this is the old shell game, a sleight of hand so that we do not ask the simplest of questions. Could it be that the customs and beliefs of all these Indo-European peoples originated from one common origin, from whence the ancient mound builders also came? They will never admit this because it would be admitting that everything good and just in this world originated in the far north Aryan homeland. Therefore, exposing the enemy to be a professional liar, who throughout the ages, has usurped the Good God's kingdom - again and again.

At this point, we should ascertain what became of the ancient giants of North America. We cannot answer what the fate of that 'lost race' was, as a whole, but we can document what happened to the remnant that still existed at the time of the Indian. Let us look once more to the honorable Josiah Priest:

"And that they were exterminated by the Indians, we prove from their tradition, which relates that in the southern States, but particularly that of Kentucky, had been once settled by white people, and that they had been exterminated by war.

In 1800, some Indians of the Sacs tribe were at St. Louis, who on hearing it said that Kentucky was inhabited by white people, expressed much astonishment that any person should live in Kentucky, as it had been a place where much blood was shed, and that it was filled with the manes or souls of the butchered white inhabitants, a people who had arts among them unknown to the Indians. Even the word Kentucky, the name of the chief river of the State, signifies river of blood."

Rivers of Blood

“The city now known as Lexington, Kentucky, is built of the dust of a dead metropolis of a lost race, of whose name, and language, and history not a vestige is left. Even the bare fact of the existence of such a city, and such a people, on the site of the present Lexington, would never have been known but for the rapidly decaying remnants of ruins found by early pioneers and adventurers to the ‘Elkhorn lauds.’ But that these remains of a great city and a mighty people did exist, there can be not the shadow of a doubt...Other authors, eminent and learned, almost without number, have discussed this subject, but their views are as conflicting as those already mentioned, and nothing is satisfactory, except the negative assurance that the real first settlers of Lexington, the State of Kentucky, and the entire Mississippi valley, were not the American Indians, as no Indian nation has ever built walled cities, defended by entrenchments, or buried their dead in sepulchers hewn in the solid rock.”

– George W. Ranck, *History of Lexington, Kentucky* (1872)

In an earlier work from 1806, *Travels In America*, Thomas Ashe had further elaborated on a vast network of huge caverns originally discovered in 1783 beneath the city of Lexington:

”These mummies were very strange looking, of unusually tall stature, and had red hair. The local native Americans claimed that these were the remnants of an ancient race predating their own; one that died out long ago and about which they knew very little...

How these bodies were embalmed, how long preserved, by what nations, and from what people descended, no opinion can be formed, nor any calculation made, but what must result from speculative fancy and wild conjecture. For my part, I am lost in the deepest ignorance. My reading affords me no knowledge, my travels no light. I have neither read nor known of any of the North American Indians who formed catacombs for their dead, or who were acquainted with the art of preservation by embalming.”

‘About which they knew very little’... with the many native legends of the genocide, which they committed upon the last survivors of a ‘lost race’, it is hard to believe that they were being honest with Ashe. Nevertheless, from the Appalachian mountains of the east to the deserts of the west we have plenty of evidence of their fate. This ancient war of extermination seems to have been centered in the area of Tennessee and Kentucky, or perhaps that area is where events were bloodiest (as mentioned, Kentucky means ‘place or river of blood’).

Tales from the Cherokee nation of the Tennessee and North Carolina region help to enlighten us about these past events. The Keetoowah (a clan of the Cherokee nation) relate the story of a people known as the Ani-Kutani, a clan of priest-kings and religious aristocracy. They were the ‘Fire Priests’ of Cherokee legend and only they had the power to light or extinguish the eternal flame with the words ‘I come from above’. The fact that the sacred fire had to be began by seven different kinds of wood, an Aryan custom, only furthers our convictions. Anytime we hear of an ancient ‘priest-king’ legacy, especially when dealing with the eternal flame, we are scratching the surface of a very old Hyperborean tradition, which is that of the Armanen.

Myths of the Cherokee by James Mooney (1900) is the ‘go to’ book for the establishment. In that work, even Mooney must give credence to the ‘theory’, based on the actual Native American legend, identifying the Ani-Kutani as the last vestige of an earlier race of mound builders. A people who had knowledge far beyond that of the Indian.

In the 1823 book, *The Natural and Aboriginal History of Tennessee*, Judge John Haywood wrote:

“Tradition states that such persons lived among their ancestors and were deemed superior, and were extirpated long ago.”

Extirpated by whom we may ask? The story that is told is that because of the excessive abuse of their power eventually the natives turned on the Ani-Kutani and exterminated them down to the very last child. There was an all-out war of Genocide. We do not doubt that this remnant of ancient Aryans may have become corrupt and overreached themselves (for there is something dark

about mummification), but just as viable would be that the natives could not comprehend the Ani-Kutani in the same manner as a resentful child does not understand why their father is a 'tyrant'. We may never know, but what we do know is that the Indians fell upon those ancient ones like a tsunami.

Falling back westward, the survivors probably had enough time to regroup in Kentucky and make a stand, hence, the cursed 'land of blood'. These are the same 'Red haired mummies' of Lexington. Following their genocide is made easy once we realize that this is who they were.

From the eastern state of Kentucky to the deserts of the west, the remains of red haired giants have been found (there were also blondes and brunettes, but the red hair usually makes the headlines of reports). This worldwide phenomenon is reported with more detail in communist China than in the United States due to the immense cover up in North America.

A well documented case is recorded at the Spirit Cave in Lovelock, Nevada. It was 1911 when they first began finding the remains of red haired giants in the cave. The Paiute Indians have a tale about their ancestors killing all the red haired giants whom they called the 'Si-Te-Cah'. These mummies and those of Kentucky are part of the same horrific tale.

There is an informative article written by an investigative researcher by the name of Terrence Aym. In the article, he gave a detailed report of the history of Spirit Cave. We believe that his findings are conclusive:

“And it's the state of Nevada that the story of the native Paiute's wars against the giant red-haired men transformed from a local myth to a scientific reality during 1924 when the Lovelock Caves were excavated. At one time the Lovelock Cave was known as Horseshoe cave because of its U-shaped interior. The cavern is approximately 40-feet deep and 60-feet wide. The Paiutes, a Native-American tribe indigenous to parts of Nevada, Utah and Arizona, told early white settlers about their ancestors' battles with a ferocious race of white, red-haired giants. According to the Paiutes, the giants were already living in the area...The Paiutes told the early settlers that after many years of warfare, all the tribes in the area finally joined together to rid

themselves of the giants...the tribal chiefs had warriors fill the entrance to the cavern with brush and then set it on fire in a bid to force the giants out of the cave. The few that did emerge were instantly slain with volleys of arrows. The giants that remained inside the cavern were asphyxiated.

Thousands of years later, the cave was rediscovered and found to be loaded with bat guano almost 6-feet deep. Decaying bat guano becomes saltpeter, the chief ingredient of gunpowder, and was very valuable. Therefore, in 1911 a company was created specifically to mine the guano. As the mining operation progressed, skeletons and fossils were found...over 10,000 artifacts were unearthed including the mummified remains of two red-haired giants—one, a female 6.5-feet tall, the other male, over 8-feet tall. Many of the artifacts (but not the giants) can be viewed at the small natural history museum located in Winnemucca, Nevada. As the excavation of the cave progressed, the archaeologists came to the inescapable conclusion that the Paiutes myth was no myth; it was true. What led them to this realization were the discovery of many broken arrows that had been shot into the cave and a dark layer of burned material under sections of the overlaying guano.”

Back in 1994, the Nevada State Museum shocked the world when they radiocarbon dated artifacts from the Spirit Cave that had been shelved since the 1940's. They discovered that the remains were over 9,000 years old and not 'Native American', thus contradicting a century of false propaganda. The local council of the Amerindians have been trying to gain possession of the artifacts ever since.

In the book, *Sacred Places, North America: 108 Destinations*, Brad Olsen tells us:

“Such findings as Caucasian, mummies did not bode well with mainstream archeologists or Paiute historians. After the fanfare of the Lovelock cave discoveries simmered down, much of the skeletal remains were stolen, destroyed or lost. And since the remains did not fit with the local Indian profile with regard to stature and hair color, most modern Native American historians

hoped those red haired giants would just go away. Yet discoveries of extremely tall Caucasian skeletons kept popping up all around the ancient Lake Lahontan region.”

It actually becomes almost comical when observing the ‘Native American Councils’ who fight with injunctions against any investigation into the origin of the proto-Aryan remains found in the States. It would seem that they are trying to outdo the ‘slaves of Atlantis’, Old Testament Bible thumpers, the Smithsonian Institute, the Jesuits and anyone else involved in the cover up. They have good reason to. Can we imagine the rug that would be pulled out from underneath them if a new history was accepted that said when they arrived there was still a remnant of a great civilization here, a remnant they have always called the Ancient Ones, The Ancient Ones who helped the Indian in many ways and, in a show of ‘Native American’ gratitude, were systematically wiped out? We know they have suffered under the forked tongue politician, but they shouldn’t propagate the lies of the ‘slaves of Atlantis’. It goes against their nature.

The Amerindian tribes all have, what are quickly becoming lost, legends of the Ancient Ones. What makes the term ‘Ancient Ones’ an intriguing subject, we have already written of before in *The Complete Armanen*. We quote:

“In the American southwest there is an ancient Klan of Indians known as the Hopi. They are unique in many ways. The Hopi claim their Ancestors are the Hisatsinom, which means the old ones or ancient ones. Other tribes call them the Anasazi meaning the old ones who are not us or the enemy of our ancestors and they call the Hopi the dead ones! Kinsman, there is great and hidden meaning in these interpretations.”

In the very name ‘Anasazi’, which is the official name that is accepted for the ancient ‘cliff dwellers’ of North America (and very reminiscent of the Cloud People), we again find a reference alluding to the sad fate of that ancient ‘lost race’. We are also given a clue to where we may find a purer description of the saga of the Ancient Ones (we refer the reader to, *The Complete Armanen*, for a further explanation of the mysterious Hopi).

The Hopi have a tradition concerning their emergence from the Underworld. The story says that during a cataclysmic event their ancestors took refuge with whom they call the 'Ant people' (a description of how they lived; underneath with entrances at mounds and identical to the Tuatha de Danann). When the threat had passed, the ancestors emerged from the earth with precise migration instructions given by the God Massau, who is 'the First and the Last'. Below is a picture of that ancient instruction which they performed, known as, the 'Hopi pattern of Emergence'. Dispersing in the four directions and turning at the allotted times, the migration begins to take on the look of a pilgrimage or certainly some kind of premeditated spiritual act.

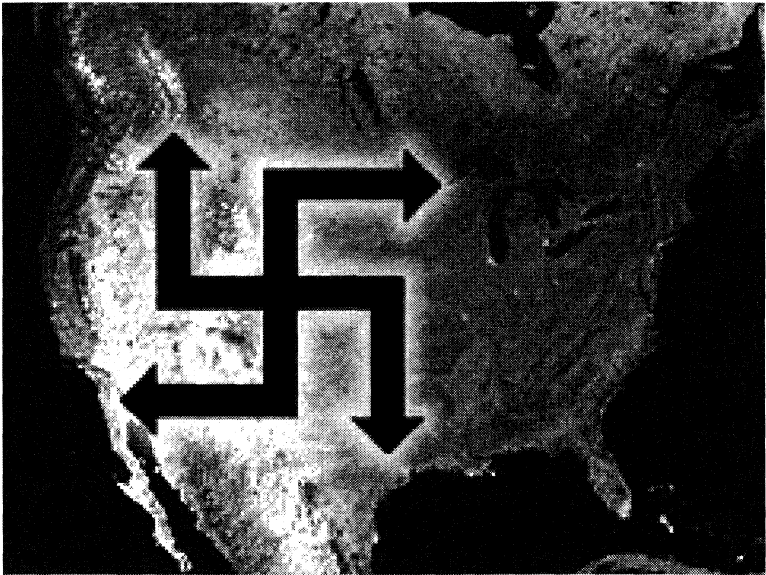

'Hopi pattern of Emergence'

The ancient trek of the ancestors of the Hopi should quickly bring to mind the 'Exodus' and the 'way of return' revealed by Master Serrano. He speaks of this very kind of migrations and their Hyperborean origins. Indeed, it seems that wherever we find the Swastika we shall find a fragment of Thule. We find much evidence of this back in the central states of North America, that is, once they dig deep enough past the arrowheads.

The Ohio and Mississippi Valleys

The state of Ohio is covered with earthworks and the remains of giants have been discovered statewide. At the Hopewell complex near Chillicothe, Ohio many copper made artifacts have been found. What makes this interesting is that in the area of Lake Superior ancient copper mines have been discovered. We are speaking of mines that operated for centuries mining the richest copper in the world and before recorded history. There are researchers who claim that the copper was carried away as far as Egypt. We are not disputing that, but we are more interested in the copper finds right here in the U.S.

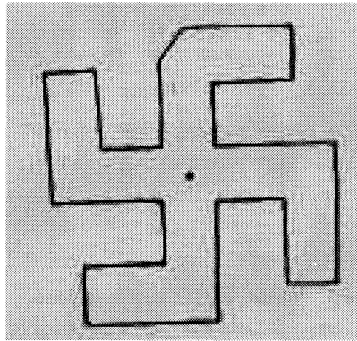

This Swastika design on a copper plate was found in a Hopewell mound along with the etched stone below.

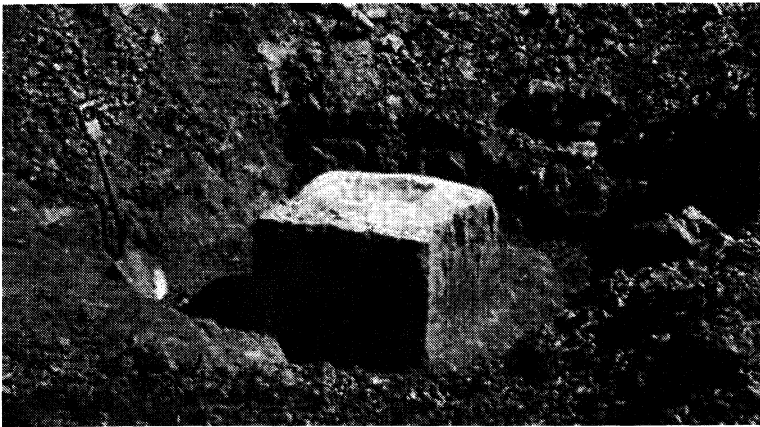

At the confluence of the Ohio and Mississippi rivers is where the first French explorers wrote of an 'ancient fort'. As previously mentioned, the confluence of the two great rivers is the heart of 'Little Egypt' and the location of Cairo, Illinois. Southern Illinois has been nicknamed 'Little Egypt' since the early 1800's. There were many odd finds by early pioneers and they mistook them to be Egyptian. It is in the names; wherever we find titles such as, Memphis, Karnak, Thebes, Cairo, the Egyptian cave and so on, is where artifacts had been discovered and believed to be of Egyptian origin. Their mistake is understandable. The powers that be knew better. They hid the ancient history of America and ridicule any researchers who dare to ask too many questions. Fabricated stories, such as the 'Burrows Cave', damage the creditability of the older, genuine discoveries, discoveries that are now buried and hard to come by.

The reason for similarities is that they have the same origin and it is not Egyptian nor Sumerian or anywhere else in the east for that matter. The survivors of the last great Golden Age dispersed themselves across the world before and after the Spiritual catastrophe. The great megaliths they built were a sort of Spiritual acupuncture of the earth.

Near every legitimate Pyramid was also a wheel of some sort. Rather it be a stone or wooden circle or a lake or a moat is not important. What is significant is that it was Feminine. Just as the Pyramid is the Tower and is Masculine. It is sacred geometry and we find the two principles incorporated wherever there is culture. Fountains are still very popular; a tree by a spring. The Church did a splendid job of including both in one structure as the bell in the tower. Many times this sacred art has been accomplished unbeknownst to the builder. It is the 'Blood Memory' or what we Armanen also know as 'Minne'.

There are legends of the Manu-Tara 'Birdman' atop the Pyramids communing with the Ancient Ones. Strange tales have been told as to what the people below saw transpire up there in the clouds. They are Nordic in nature. The Manu-Tara is the one who has been liberated. He has again become the son of God, the *absolute man*, who has rediscovered or awakened the Father within. He has re-earned his wings, while those whose wings have been clipped remain earthbound. But what of those who

At the confluence of the Ohio and Mississippi rivers is where the first French explorers wrote of an 'ancient fort'. As previously mentioned, the confluence of the two great rivers is the heart of 'Little Egypt' and the location of Cairo, Illinois. Southern Illinois has been nicknamed 'Little Egypt' since the early 1800's. There were many odd finds by early pioneers and they mistook them to be Egyptian. It is in the names; wherever we find titles such as, Memphis, Karnak, Thebes, Cairo, the Egyptian cave and so on, is where artifacts had been discovered and believed to be of Egyptian origin. Their mistake is understandable. The powers that be knew better. They hid the ancient history of America and ridicule any researchers who dare to ask too many questions. Fabricated stories, such as the 'Burrows Cave', damage the creditability of the older, genuine discoveries, discoveries that are now buried and hard to come by.

The reason for similarities is that they have the same origin and it is not Egyptian nor Sumerian or anywhere else in the east for that matter. The survivors of the last great Golden Age dispersed themselves across the world before and after the Spiritual catastrophe. The great megaliths they built were a sort of Spiritual acupuncture of the earth.

Near every legitimate Pyramid was also a wheel of some sort. Rather it be a stone or wooden circle or a lake or a moat is not important. What is significant is that it was Feminine. Just as the Pyramid is the Tower and is Masculine. It is sacred geometry and we find the two principles incorporated wherever there is culture. Fountains are still very popular; a tree by a spring. The Church did a splendid job of including both in one structure as the bell in the tower. Many times this sacred art has been accomplished unbeknownst to the builder. It is the 'Blood Memory' or what we Armanen also know as 'Minne'.

There are legends of the Manu-Tara 'Birdman' atop the Pyramids communing with the Ancient Ones. Strange tales have been told as to what the people below saw transpire up there in the clouds. They are Nordic in nature. The Manu-Tara is the one who has been liberated. He has again become the son of God, the *absolute man*, who has rediscovered or awakened the Father within. He has re-earned his wings, while those whose wings have been clipped remain earthbound. But what of those who

clipped their own wings? The Vira who has voluntarily made the ultimate commitment. In the ‘eternal return’ of things – this is exactly what Cortes did when he destroyed his ships with the words ‘conquer or die’. They will give their dream a face or lose their immortal life trying.

The megaliths were doorways to the spiritual world. Portals of subtle streams of Divine Power were properly maintained (Ley lines), therefore, making available an orderly, higher consciousness to the prisoners of material, and it was working.

The negative forces of nature would have none of this. Just as today, the ‘slaves of Atlantis’ and their Masters would rather destroy everything than give it up (which is exactly what happened back in that ‘turn of the wheel’).

Interesting, is that nearly all these places we have spoken of are known to have caverns and such that lie beneath, but the real shocking evidence is the labyrinth of made tunnels. One such example is in, *The Conquistadors: First-person Accounts of the Conquest of Mexico*, a book published by Patricia de Fuentes, where there is a story related by the Conquistadors:

“The marvelous structure of the tunnels located at the pueblo of Puchuta, being of the most firm and solid cement, runs and continues through the interior of the land for the prolonged distance of nine leagues to the pueblo of Tecpan, Guatemala. It is a proof of the power of these ancient kings and their vassals.”

Nine leagues is over thirty miles long. Are these tunnels and caverns where the Ancient ones disappear to, time and again? Who builds their sacred sites on top of these subterranean worlds without the thought of using them? They are definitely going somewhere...the White Gods, ancient Mound builders, Tuatha de Danaan and their likes, always leave.

We know that the last catastrophic event destroyed their civilizations, but we are also aware that those who held true to the Hyperborean standard were forewarned. We find this in the story of Noah, which is a later version of the ‘Epic of Gilgamesh’, or even in the story of the Hopi (the only natives who claim the ancients as their ancestors). Those who remained pure held true and were spared – the Hyperboreans were spared.

It is granted that interbreeding and genocide played a part in their departure, but that was the fate of a remnant. The mass of Aryan Giants were suddenly gone as quick as they had came. To where? The only people on the face of the earth that they could have hidden amongst were the North men. Vikings were still gigantic in stature only 1000 years ago. Runes have been documented from Minnesota to Paraguay. The Nordic connection cannot be denied. Yet, there is another place, another world within a world that continues to surface every time we speak of a peoples, such as, Hitler's Final Battalion and their fantastic technologies, who simply 'vanished.' Could they be in that other earth still called Paradise? There is no other viable answer for the endless stream of mysterious and mighty people who disappear from history just as quickly as they had arrived.

'Paradise Found'

"How do scientists explain the fact that when we go north it becomes colder up to a certain point and then begins to get warm? How do they explain the further fact that the source of this warmth is not any influence from the south but a series of currents of warm water and of warm winds from the north – supposed to be land of solid ice? Where can these currents come from? How could they come from anything else but an open sea? And why should there be a warm open sea at the very place where scientists expect to find eternal ice? Where could this warm water possibly come from?

Why also should explorers find the inhospitable ice cliffs of the far north covered in large areas with the red pollen of an unknown plant? And why should they find the seeds of tropical plants floating in these waters - when they are not found in more southern waters? How should logs and branches of trees, sometimes with fresh buds on them be found in these waters, all being borne down by the warm currents from the north?"

- Quoted from Marshall Gardner's book, *A Journey to the Earth's Interior Or Have the Poles Really Been Discovered?*

Hyperborea, hidden to us in its present form, has never ceased to exist. Even in the times of Atlantis, the original homeland had already been transformed. The best part of Atlantis was the Hyperborean memory and tradition. The Aryan Spirit of Hyperborea is what made the White Island great. The mentality of the 'slaves of Atlantis' is what destroyed it. This should not be hard to imagine for it is the exact struggle we still face on a lower level. The battle ever wages on between the Aryan Spirit of Honor and the petty materialism of the Jewish God of the Old Testament.

And it is from the Old Testament that we find a reasonable explanation for the present predicament. We are told in the *Book of Genesis* that Adam and Eve were 'expelled' from Paradise. Eden is doing quite fine; it is our world that is upside down. As prisoners in time, most cannot see beyond the veil (or door) into that parallel dimension. It is so close and yet so far away.

The *Book of Genesis* is actually a plagiarization of the much older Indo-European myths and legends, in which there are countless references to the lost homeland. The Garden of Eden is Mount Meru, but there is no need to take our word for it. Scholars have been claiming this ever since they could read Sanskrit. The famed French archeologist Francois Lenormant tells us:

“The reader cannot have failed to be struck, as the first explorers of Sanskrit literature have been, with the close analogy, we might even say the perfect identity, of all the essential features of the typical description of Mount Meru in the Puranas with the topography of Eden in the second chapter of Genesis.”

Mount Meru is the name given by the ancient Vedic Aryans for the Aryan homeland. It is described as the center from where the four cardinal directions originate. Thus, it is the ‘fifth element’ and the hub of the wheel, or the heart, the core and center. If we recall the sacred geometry of the ancient cities and complexes, we can see that the architects followed this same exact pattern. In several places the center of this divine science has been named the ‘navel of the world’, from whence the World Tree, the Axis Mundi, shoots forth to make a beautiful Hagal rune. The World Axis of the Axis Powers is the trunk of the Tree of Life and this World Tree grows from Mount Meru.

It is said that the starry skies revolve around Mount Meru. Hence, it is the Pole star or North star. Because of precession the position of the Polaris (Pole star) changes every so many thousands of years. The starry sky still revolves in the north, regardless of which star is ‘the nail’ or Pole Star because that is where the Column shoots forth at. King Arctus (Arthur) of the Arctic circle, which is, the Great Bear (Big Dipper), circles the shaft that proceeds from Mount Meru. So, if the earth is on an Axis that runs the course of both Poles and projects from the North Pole to the North Star – where does that put Mount Meru, the center, from which the Heavens circle?

“At the centre of the earth,
There stands a great mountain,

‘Final Battalion’

Lord of snows, majestic, rooted in the sea,
Its summit wreathed in clouds;
A measuring rod for all creation.”

- Kalidasa (Sanskrit Bard from the 4th century)

This mystery has been explained as the Hollow Earth. Hollow Earth proponents put forth a fascinating perspective and they are correct in a sense but often enough when their logical minds encounter a problem they cannot explain – the explanations can become absurd. The spiritual essence is what the ‘Hollow Earth Theory’ lacks. The Other Earth is not somewhere that one simply walks into. The Land beyond the Poles is the land ever beyond the horizon, that place beyond the lights, beyond the north wind - one must be invited or have earned it. Nevertheless, it would appear that having another habitat somewhere beneath us, which has entrances that a Boy Scout might find, makes the quandary easier to understand.



There are several writers who have written of a Paradise inside the earth with great detail. In his book (probably borrowed from the visionary Saint Yves d'Alveydre), *Beasts, Men and Gods*, Ferdinand Ossendowski declares:

“All the people there are protected against Evil and crimes do not exist within its bournes. Science has there developed calmly and nothing is threatened with destruction. The subterranean people have reached the highest knowledge. Now it is a large kingdom, millions of men, with ‘The King of the World’ as their ruler. He knows all the forces of the world and reads all the souls of humankind and the great book of their destiny.”

There is ‘an Axis or Tree with roots where the book of destiny resides’. It doesn’t take much thought to be reminded of Yggdrasil, the World Tree of the Norsemen. It is here where our beloved ValFreya and Her entourage of Valkyries take rest in the form of swans at Urd’s well (earth’s well). Freya has many attributes, as ValFreya She is our Lady who chooses. She is the first of Valkyries who fly the world over in search of Heroes worthy of immortality. At this ‘Fountain beside a Tree’ Urda is ever carving out the destiny of both Gods and men. Odin visits regularly - ‘whither he came, thither he returns.’



ValFreya and the Swan Maidens

As we have already seen, the divine kingdom of the inner earth has been coined Agharti. This name references Asgard, home of our Nordic Gods and ancestors. In *Nos*, Master Serrano gave some particular information in relation to the 'inner earth':

"The entrances to the Interior Earth are to be found at the poles, as well as in the Antarctic Oases and possibly on the top of this mountain. They can be reached by travelling through the deep waters which flow beneath the ices.

In this Interior Earth are the Cities of Agharti, Shambhalla and the Caesars, inhabited by the immortal Siddhas. There the Golden Age still exists. The Discs of Light, covered in orichalcum, fly out from there. They carried our guide off to a place of safety. It is the invulnerable Paradise which our people have rediscovered, where the science of resurrection and eternal love is guarded. It is the starting point of the journey to our star."

'It is the starting point of the journey to our star'... So profound and so typical of the late Master to fit tens of thousands of years of the Aryan Spirit into an 11 word sentence. Serrano is referring to the 'Bright and True Morning Star'. It is the most vivid of stars, and yet it is not a star. The oldest legends always point to the Morning Star as an integral part of our experience. There is little doubt that it is a part of our origin. The true mission of the Morning Star is the ultimate commitment in all of God's creation. It is a Hero's mission: a selfless sacrifice for the good of others.

The lost Hyperborea lives in our hearts as much as in any hidden 'other' world. The Hero's mission is not so much about locating the hidden Paradise, that Heavenly abode where the just souls still reside. In 'Gimle' (Heaven), the only pain the righteous suffer is their sorrow for their lost brothers. The noble son knows no Heaven as long as his people suffer. Therefore, the true mission of the Hero is to bring Hyperborea here.

It's purest form has always come from the North. The Aryan Ideal becomes hazy as it is trampled upon in its wanderings throughout the world. For example, the self-sacrifice in the figure of Jesus Christ is as old as time immemorial. The true origin of the Christ Mythos is Atlantis where there was a

Solar Kristianity which retold the betrayal and fall of the good King of Hyperborea and it has been retold and relived ever since.

In Truth, it does not matter if we win or lose. The only thing that counts is if we remained Loyal and True. This world of Maya is an illusion. We have already won. We have won through our willingness to suffer for something other than ourselves, which is, to sacrifice. The Father will not leave the Mother, the Mother will not leave the children, the children will not leave the Father or the Mother, and the Hero will suffer for his people. There is nothing that can stop this kind of heroic, sacrificial love. The enemy thinks he can buy anything with his money; he cannot. While they, in their selfishness, cannot rise above themselves – we carry on for the one standing next to us or for the one to come, an Ideal. This kind of loyalty is called Comradeship and even if it should take one million years for the sleeping Aryan to wake up and stop being used - we cannot do anything but win. Yes, the Hero's burning heart of A-Mor has already won this war. We are just not aware of it yet. That privileged information must be earned.

The love of the Fuhrer that compelled him to wage a suicidal, just war in the east as well as his love for the Aryan peoples that prevented his use of Atomic weapons is how Adolf Hitler won by losing. Christ-like, he opened the door that had been shut. Truly, 'a Savior to his people'. *In their need*, National Socialists discovered the Divine science (made contact) beyond space and time, just as we now *need* to rediscover the path of the Noble Spirit.

We, the last remnant of loyal Aryans in a lost world, must expel all forms of rationalism from our thinking. No 'logical' thought can overcome the technological nightmare we are living. The unbreakable faith of the Saint and the unstoppable valor of the Hero will both be riding in a Vril disc flown on the wings of Blood Memory. Again, it is Master Serrano who says it best:

"The question spontaneously arising today is: 'Why no great power, since the disastrous failed attempt by Admiral Byrd, has claimed possession, embarked, investigated or explored the region of Neuschwabenland?' Neither the Federal Germany of

today, nor East Germany has reclaimed those territories. The answer was given in 1980 by the magazine 'Das Neue Zeitalter'. 'Since 1946, the first flying saucers have come from Antarctica. Those navies not only visited distinct areas of the earth, but also other planets in the solar system. It is quite possible flying saucers with life from other worlds have already made contact with the people of New Swabia. With their aid and assistance they may have already developed on our planet a completely different and very advanced science in German bases of the Third Reich with extensive cosmic implications. Seen from that angle, neither the United States of America, nor Soviet Russia is the foremost world power, but Neuschwabenland in the Antarctic, with a vast technological superiority.' That would explain why no one has dared to touch those territories and why even the moon expeditions have been suspended. The Hitlerists are already there, and many other worlds. The resurrected Vîras, transmuted into Divyas. There is indeed a Face in the Lunar Disk..."

The esoteric Third Reich had been successful in building flying discs that defied the known Laws of nature. We say esoteric because it was the science of implosion from the God path of the Race of Paradise that made all of this a reality. The reality of a Black (hidden) Sun created from an implosion of Green (resurrected) Light that in turn implodes creation in the same manner as a Mothers life giving womb.

Those Great Souls who reside on the other earth are the selfless; they stay to help. When a Noble Soul has advanced past his mere material existence and the door Beyond the Poles is opened they are liberated. Once freed from this spiritual slavery the Personality has many destinations to choose from (my Father has many mansions), because the Great Liberator does not believe in slavery. Most leave, but He stays and so do those who love Him too much to leave, because 'their Loyalty is their Honor'. He gives a great power to those who know how to use it. That power is Vril.

Vril

Today, many would lead one to believe that the word Vril comes from Lytton's esoteric novel, *Vril-ya The Coming Race*. It is true that Lytton was an initiate, but he rightfully borrowed the word from ancient sources. A very good description of Vril comes to us in an interesting little book published in 1911 titled, *Vril – Vital Magnetism*:

“In the Arcane Teaching, the term ‘Vril’ indicates the universal principle of vital-energy, life-force, or vital magnetism, as it is sometimes called. The term itself is believed to have had its origin in the language of ancient Atlantis. Tradition holds that the Atlantean root *vri*, meaning life, is the source of the word Vril, expressing the idea of the vital principle or life-energy. This original root term is believed to have influenced similar elementary terms in Sanscrit, and through this that great source of tongues, Latin. From Latin we find words indicating manly vigor, energy, virility in our own languages which undoubtedly owe their origin to the original Atlantean root term *vri* from which our term is derived. In the ancient Greek language we find the term *veros*, meaning ‘a hero.’ In the Sanscrit we discover *vira*, meaning ‘a hero,’ and in the ancient Irish *vear*, meaning ‘a man.’ The Gothic *wair*, and the Anglo-Saxon *wer*, each meaning ‘a man,’ (from which our terms ‘virile, virility,’ originated) also appear to have been derived from the Atlantean term *vri*, or ‘life.’ It was very natural to identify the concept of ‘man’ with ‘life.’ In our own language the terms ‘virile’ and ‘virility’ indicate life-force or vital-energy, particularly in the sense of procreative power, the usage of these terms bearing out the above stated theory of their origin. Bulwer, who was well-versed in occult tradition and terms, used the term ‘vril’ in one of his novels, to indicate a mysterious form of energy employed by a newly discovered and highly advanced race of people, upon whose doings his story was based. It is almost certain that Bulwer borrowed this term from some of the ancient occult writings, with which he was familiar, and that the ancient Arcane term ‘vril,’ was known to him.”

Vril is the energy of life that holds all things together. It is youth and vigor and that of the Green Ray. The Fountain of Youth is also the Graal. It is a fountain of Vril. For us Armanen it is also known as the Odal Force. A Christian may say it is the Holy Spirit or Paraclete (a word borrowed from the Cathars). Vril has many names and pervades all things. Vril flows out from the Holy Graal and is the cause of life as we know it. In this world the Holy (Ley) lines are its primary avenues. The Divine, Creative Principle freely gives and makes available the Vril energy to His creation. We have all experienced it at one time or another. Harnessing Vril is what gives that feeling of invincibility when one feels like they can do no wrong. When one is aligned with the Poles or *in their groove* it is a magical feeling. The same as Law, it is passive in nature and just as fire and ice (water), and electricity and magnetism, it is balanced, meaning that it works according to the Laws of Creation. Creation is an implosion.

The implosion versus explosion is at the core basis of what we know as good versus evil. The creative implosion is limitless and *absolute* in comparison to the temporal, destructive element of explosion. Only from the AllFather comes the Power to create out of nothing. The same as with the Spirit, Divine implosion is beyond time and cannot be measured. This technology exceeds the Laws of gravity, space and time. Thus, we arrive at the flying discs. Vril has no boundaries once we have been unchained. Vril is implosion, it comes from within. As it is above so it is below, the Spirit of Truth and Holy Swastika are within us, and if it is in us then we are destined to create it. Vril discs are a possibility; therefore, the Aryan Spirit of Genius will create them. If they will, then they already have.

It is not a coincidence Vril and Will are very similar words. Both are of Divine origin. The will is what separates us from mere animals. Let us not make the mistake of considering compellation and will as being the same. The 'slaves of Atlantis' have tremendous focus on materialism. This is not will, it comes from their very nature to destroy all Divine currents so that they need not be bothered by the Godly distractions, such as, a conscience. He is compelled to serve mammon. The Aryan has a tremendous sense of Honor, he is born with it, this is not will.

It is the Will that grants us the capability of rising above the base animal instincts. Providence has given men the gift of reason and from this we are capable of finding and using the greater gift, Will. The enemy would like to be rid of Will once and for all because it is the Will that makes a man more than a slave. Slavery is the way of this world and the slaves of the flesh are the worst of all.

Early on, Schopenhauer told us that the Will is of God when he stated:

“My will is absolute, standing above all corporeality and above nature. It is holy in origin, and its holiness is without limitation.”

The Great Ones use their Will to accumulate and direct the Vril. To use one’s Will constructively is to master life. It is as the Armanen Rune Masters tell us again and again, “control yourself and then you shall control the all.” This is the Will to Power, the Uberman. We shall not have one without the other.

In, *The Myth of the 20th Century*, Alfred Rosenberg gave a nearly perfect description in ten simple words:

“The will is the soul imprint of clear sighted energy.”

Those familiar with the Armanen Futhorkh know of the internal and *eternal* relationship between the Odal and Os Runes; Will and Vril work in a similar fashion.

Our Northern Ancestors had a profound understanding of what we call Vril. In the exoteric they strongly identified it with Luck. Truly, they enjoyed testing their Luck in a game more than the game itself. They knew that Luck was no mere coincidence, but rather an entity that wove the raiment’s of time, a condition of the Soul, a karmic chain of events governed by the Nornen who shaped Luck with a most mysterious *Power*; ‘A Power that is too mighty to name.’ The Graal Stone radiates this *Power*, that ‘will not cook the food of a coward.’ It is said that Heaven is to be in the presence of God, beyond the veil of the Graal Castle is Paradise where Parsival awaits his brothers. There is no Vril without the Graal, as there is no creation without the Creator.

We can search for Vril endlessly, but without our Luck we

shall not find it. The Hero, that is, the Vira, has it with him always, or as the Rune Master Siegfried Kummer once said, ‘As thou art, so is thy Graal.’ This is why the enemy will always be playing catch up to Hitler’s Final Battalion, because they have not earned it. This is very embarrassing for them, and therefore one of the main reasons for the vast cover up and total disinformation campaign about the true origin of the U.F.O. phenomena (MJ12 has been a disinformation think tank since its very conception. They have one priority, to make sure we never learn the true origin of the U.F.O.). The Race of Paradise befriended the Third Reich because they had earned it. The Vrill source is our reward. The enemy cannot comprehend this simple truth, the same as Vrill, it is hidden from them. The Hero equipped with his Blood Memory and his Vrill will one day usher in the new Golden Age or as the late great Master says:

“It is the power that will come to save all our heroes and those that remain Loyal and stay on the right path at the very moment when we think all is lost. ‘The Ultimate Battalion’ will enter into combat at a higher energy vibration when the destruction of our world becomes inevitable.”

This thread of thought is universal wherever we find the Noble Soul. The traditional Catholic Bishop Richard Williamson, who is famous for his rejection of the holocaust, recently posted in his weekly address:

“The hour of God and of the immaculate Heart will come (as she has said) only when everything seems lost, which must include the little SSPX.”

So are things bad and are they only going to get worse? The answer is absolutely yes, but we have friends out there and they do not let those who *deserve* better fall. This does not mean that we will not suffer, but as Alfred Rosenberg had said, ‘the Nordic man does not shun suffering and in a certain way he welcomes it, because he knows the benefits that arise from it.’ The Aryan knows the necessity of sacrifice and sees that it is the path to the Graal. There is a fall much worse than suffering; it is the fall of

losing your 'Ich', one's Honor, our very soul, or the personality. That is the most precious spark of God that none of us can lose unless we give it up, and we can thank the Gods for that. We can and should be grateful for the preservation of our immortality, which resides in our blood, and fight for it until our very last breath. Funny, that in today's confusion we have an array of folks who believe they are right. And as long as they hold true to that which they feel, even they have preserved their Ich. They will advance forward in another 'turn of the wheel. It is only when we forsake our Honor that we truly lose the Noble Spirit.

It was the pre-dated cataclysmic event that brought the Noble Hyperborean Spirit here in search of what had been lost. The Dark Lord of material overstepped his boundaries when he saw the opportunity. Thus, disturbing the consciousness of the Light, the Heroes of God came raining down upon Him to right this wrong. The dark Lord is not naive, perhaps this is exactly what He wanted in order to spiritually elevate the world of mass and beasts. And what of our mission? To risk our very immortality in this land of flesh as part of the ultimate mission and Hero's quest, or as the great souls say 'to give God a face' – what kind of glory can match that? It would seem that perhaps we have two brothers working together the whole time.

From Whence We Came

Perhaps, we should begin with asking the most pertinent question. Does our consciousness come from the stars or from an ape? Did qualities, such as, awareness, reason, honor, duty, loyalty, love, sacrifice, service, nobility, etc. evolve from algae or did Divine Consciousness arrive from somewhere else? We need not look any further than the great Dietrich Eckart for our answer:

“For us the soul is divine, of which the Jew, on the other hand, knows nothing. The Kingdom of Heaven is within you, thus God also, who belongs to the Kingdom of Heaven. We feel our soul is immortal, eternal from the beginning, and therefore we refuse to be told that we are created from nothingness.”

We cannot help anyone who truly believes that our Divine Consciousness evolved from an ape, but for those who seek an answer to the riddle – let us revisit a saga from the dimmest past, for it is there that we shall find the answers to many of the ancient riddles and it begins with what for the last millennia has been called the royal star of Saint Michael, or the Bull's eye of Taurus - Aldebaran.

Only 5,000 years ago, due to precession, Aldebaran was the bright star of the dawn shining in the eastern sky marking the spring equinox. Under this light it is easy to see that Aldebaran or Rohini, is none other than our dear Ostara.

In Vedic literature Aldebaran is identified as the young and beautiful Maiden of Dawn and is named Rohini. The Creator Brahma, the first Prajapati, is Orion. He advances toward Her and because of this Rudra, which is an aspect of the Lord Shiva and identified with Sirius, attacks Him. Clearly what we have here is a legend to explain an out of the ordinary cosmic event. Orion and His Dog shifted towards the Bull, most likely causing Aldebaran's galaxy to become uninhabitable. To take the story literally would be folly, but all do usually reveal some tragedy in a dim and forgotten past. By all accounts, what was once there headed here or what is now here was once there.

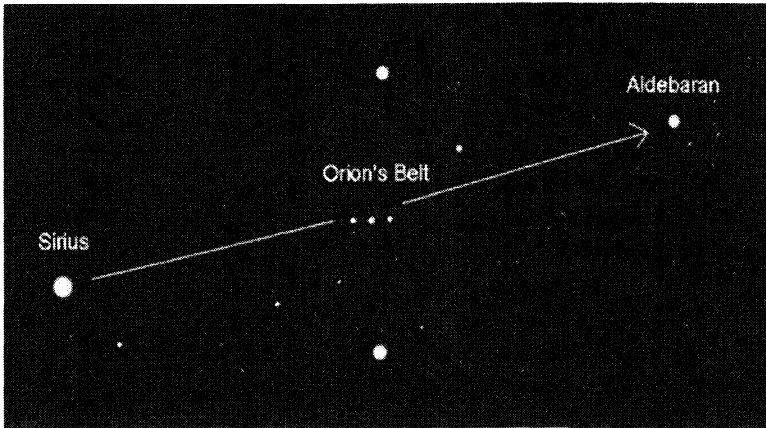

Whether it be Rudra-Shiva (Sirius) who maims Prajapati-Brahma (Orion) or an arrow striking down Orion, (who is Osiris and suffers His grave injury by the betrayal of Set) or the beloved Baldur who is killed by an arrow directed by Loki – this is usually described as a great injustice. Shiva the destroyer, Set the betrayer and Loki the trickster can be seen in some aspects as personifications of ‘the Devil’. It is only Semitic legend where we find the scenario completely reversed and again revealing the stark contrast in the two psyches. Under this pretext the words of Jesus in the Gospel of John make perfect sense; He tells the Jews that they are the children of the Devil, who was a liar and a murderer since the beginning.

Most ancient cultures revered the constellation of Orion as the origin of creation. Therefore, it is only fitting that when the divine race, which gave birth to the Aryans and brought consciousness to earth, laid out their sacred geometry in the construction of their ‘centers’, which were identical to the stars, that these locations would be named the ‘navel of the world’ or creation. The nebula that very well could be that which created our galaxy is beneath the belt or navel of Orion and corresponds to the birth place of the Lord Tonpa Shenrab Miwoche (the first Buddha), which was south of the pyramid of nine Swastikas or Mount Meru. This is certainly a setting that every Noble Armanen of the *Thing* should contemplate.

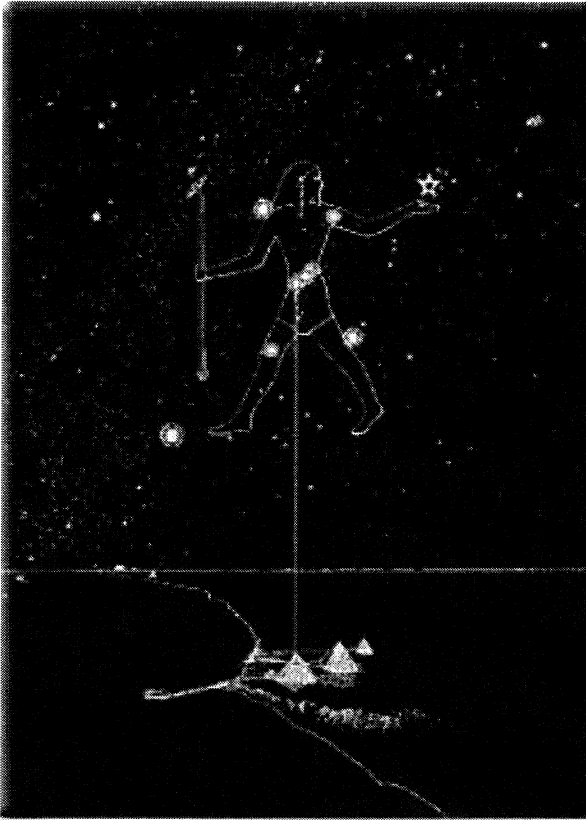

So it would seem the saga of the eternal return began and by all accounts those divine wanderers from the southeastern skies made their new home on Mallona. Known by many names in the never ending attempt to understand what happened, Mallona has been called Phaeton, Tiamat, Lucifer, Maldek (Mal-kize-dek), Astra, the fifth planet, etc. Mallona was the most splendid world of our galaxy and truly the lost Golden Age. Today, we still see its remnant in the asteroid belt that orbits in-between Mars and Jupiter. There are many legends and theories of a cosmic war that destroyed Mallona (it was probably hit by a comet or planetary body). This Spiritual Catastrophe in the eternal return is the cause of the present layout of our solar system. In all probability the core, the life or heart of Mallona, struck the earth, or is the earth, as we had alluded to in the introduction of this

work. It would seem that this was the home of the Great Mother. Mallona was the likely origin of Hermann Wirth's Ur-religion, which he rightfully claimed was the worship of the Eternal Feminine and we have his finest example in the children of Danu – the Tuatha de Danaan. She is androgynous and just as Ymir of Nordic myth, Taimaz of Sumerian and Brahma of Vedic – His/Her body makes up all of creation. In other words, we are all within the eternal God. The Gods of Order fashioned a grand design from that Ur-being, which is Urda – Earth, the original mother, from which all we know was born. But there is more, for there is still a Power behind Her.

Lord Vishnu, who is the Allfather, sleeps and dreams creation, which rises from His 'Navel' and gives life to the Creator, the Brahma. And in this way, He remains aloof from all of His creation, which is Him.

As Rosenberg and Master Serrano have already pointed out, Wirth was wrong in his promotion of Goddess worship. Order, discipline, the iron will and direction come from the Father. There is an ambiguous story that is not spoken of much which whispers that in the beginning the Cosmic Egg (which housed Her and the Father) was broken. They were separated and He has longed for Her ever since, for She is a part of He. And here is where we shall speak of the true secret of Mary, who is Lily and Freya and the good Queen of Aldebaran. In the past when religion fell into Goddess worship and degenerated into serpents and dragons, the deceitful woman, or the woman who truly behaves without a moral code, etc. it was a road of error. But in Mary we find a relationship that is quite unique and special. In other words, Lily came home. When the Morning Star came to Mary and declared to Her that She was the Mother of God, we have a magical moment that illustrates the love those two share (every love story is their story) and a great wrong is made right. In Her response we have the most beautiful trust and unwavering commitment. The Mistress of Heaven replied, 'behold the handmaid of the Lord, let it be done unto me as it is according to Thy word.' He had His She and that which had been broken (the Egg) was made whole. In Her He found the Her that He could trust, His Masterpiece. She has been His face ever since that mystery of mysteries. Just as Venus is the beautiful face of the

entourage of the Morning Star, 'Saint Mary' is the expression to identify the legions of the Holy Ghost. She is our Lady Ostara of the Dawn and it would do anyone good to love and honor Her with a true devotion. Her fidelity deserves it and She never fails.

Apparently, with the destruction of Mallona the cosmic drama of the eternal return was brought to earth, or the earth as we now know it. Our present solar system was shaped by that tragedy. There are so many 'secrets', legends and theories pertaining to this matter that one would be presumptuous to think they have it all figured out, but we may speculate.

In the 1700's, the famous German astronomer Johann Bode determined that there must have once been a fifth planet in-between Mars and Jupiter. The hypothesis became known as Bode's Law. By 1800, the German astronomer and physicist Heinrich Olbers announced that the asteroid belt was once the fifth planet which he called Phaeton after the Greek legend. In 1823, another German scholar, Johann Radlof, put forth the theory that 'Phaeton' (Photon, Woton) had been destroyed by an asteroid or comet and was responsible for the shift of the earth's axis, which caused great earth catastrophes, and that even Venus was also a remnant of Phaeton thrown or sent into its new orbit. Thus, came the terrible end of what we call the lost golden age. There is even a theory that identifies Venus with Athena and said to have been born (or projected) from the head of Zeus (Jupiter). Time and again we find the origins of Venus being associated with Mallona and Jupiter. As previously mentioned, most ancient legends describe Venus as a comet.

Many claim that it was an approaching comet which rained its debris upon the earth and destroyed the Clovis culture around 13,000 years ago (causing the last ice age). If that is true then it was surely Venus or the Moon. There are several researchers who speak of our Moon being in its present orbit for only the last 12,000 years or so:

"The old Arcadians, a Pelasgian race of the Mediterranean, also said a great Deluge overwhelmed their ancient land - the Deluge of Ogyges - before the Moon accompanied the Earth! Their ancestors were thus called, by the Greeks, pre-Selenites, which means what it says...It is curious that the ancient Mexicans

spoke of the planet Venus as lighting the eastern skies, and not the Moon...According to another extremely ancient tradition, about 9700 B.C. - this date, as I said, is based on evidence once existing (in the time of Solon, the legislator of Hellenic Athens) in the temple archives of the old Egyptian temples of Heliopolis and Sais, or Thais, on the Nile - a great comet approached the earth...it may have been some great, stellar body of a lost or dead world, from outside the galaxy of our own Milky Way of an 'island-universe', which approached our sun on a parabolic or hyperbolic course, and, having caused a grave catastrophe to our earth, vanished, never again to reappear. Or it may have been our present, dead Moon!

- Harold Wilkins

Enter Manu or Mannus (our present moon) who just as Osiris (Orion) is the progenitor of mankind and the giver of the Law or Dharma - that which will be upheld. Dharma is the Black Dog that accompanies Lord Shiva. Manu tells us in the, *Laws of Manu* (Manava Dharma-sastra), that the four legged Dharma loses one leg in every age leading towards the end and new beginning. Therefore, according to Manu, in this present age of Kali-yuga, Dharma is standing upon only one leg. The ancient High and *Secret* Tribunal of the Teutons preferred to work by the full light of Mannus - for it is they who uphold the Law.

In the *Laws of Manu*, Manu dictates a detailed account of the caste system and other significant information pertaining to creation, such as, the primordial egg and that all of creation is in the body of Brahma, but pertinent for us is Manu's affirmation that the 'internal organ' (the mind) is related to the Moon. This only makes sense if our consciousness has a Lunar origin.

The Master Guido von List gave his account in the book, *Die Religion der Ario-Germanen in ihrer Esoterik und Exoterik* (Religion of the Aryo-Germanic Folk):

"Wuotanism knows Mannus as the progenitor of humanity; Armanism, however, sees in this a code-word, which is clear enough: *Man* equals 'Man and Moon', and *us* is 'out of', which is, 'the Man from the Moon', or the lunar ancestors. A high secret of the 'Ho-He Acht' is this anthropogenesis in that it reveals that the Moon is older than the Earth and is its Father, but

that the Moon is now in a transformational state – of passing away to a new arising...the Moon had a population far superior to that of the Earth, this population was transplanted to Earth in the form of humanity...With the emergence of humanity on our earth, with the inception of the age of the Third Logos, the reverberation of divinity in humanity had arrived, and thus a new evolutionary period began for the earth itself.”

And there we have it, the uplifting of the Kingdom of Earth by the arrival of the Aryan Spirit, which von List declares to be from our present Moon while others have claimed Venus, Mars, Jupiter or that the earth is from the lost Mallona and so on. What seems to be ‘safe to say’ from these evidences of the past is that the Aryan Spirit is not of this earth and, in fact, landed here through an open door in search of what had been lost as a result of a Spiritual Catastrophe. To be honest, this event is truly when ‘the Word was made flesh’. He brought the Heavens here and so began the age of Paradise on Earth named Hyperborea.

The Vedic scholar and Nationalist hero Lokamanya Bal Gangadhar Tilak proved well the Arctic origins of the Aryan in his monumental work, *The Arctic Home of the Vedas*.

Practically every myth and legend point to the North as the location where the divine light descended upon the earth. The Arctic region (Hyperborea) had always been considered the window or door of those divine Heroes. The North star, the Pole star, is anchored by Mount Meru. By now it is obvious that divine consciousness descended upon this earth through the Northern door.

There is a wonderful story about the formation of the Pole star and the plough or Big Dipper. It is the story of a ‘Prince without a Kingdom’, who in his innocence and determination goes in search of the Creator of creators, the Hero of Hero’s, the great Lord Vishnu. It is the tale of the ‘fool’ who knows no better than to seek the mystery of mysteries, the Holy Graal. The young Dhru, who has been usurped of his Kingdom, reaches the North Pole and is told to wait and contemplate that which he seeks. His pure intentions are so strong that his meditations shake the very foundations of the earth. The Saptarishi, who are the seven sages and the bearers of Aryan religion (the Rishis),

take notice and being duly impressed, protect the boy while he prays. Eventually the Good God of all creation appears and asks Dhruv what he seeks. The boy only smiles because he has now achieved it, the Graal. Vishnu transforms Dhruv back to his rightful place as a star in the Heavens, above the world and away from all jealousy and evil. The Seven Rishis, who had protected Dhruv as he prayed, Vishnu turned into seven bright stars and placed them protectively around the little Dhruv-star where they ever rotate as the Arctus. According to this legend, Mount Meru (Paradise), the Pole star, the Great Bear Arctus (Arthur) and the Holy Graal are all irreversibly connected.

It has been shown that the ancient Aryans who migrated east (Iran, India, Mongolia) still honored the Great Bear Arctus, the Saptarishi, Big Dipper, Plough or the Old Man's Wagon as the stars who *grind out* 'the devils' and misfortune.

The Seven Sages of the Big Dipper circle the Pole star of Mount Meru, just as the chariot (Swastika) of Mithras (one of the seven sages whose home has always been in the North). Grinding and ever turning like a millstone is the Holy Swastika, which is, the Mighty One's Hammer. It is in the Northern starry skies, within the earth and within each one of us awaiting Dawn (Ostara) when the 'Wounded King' awakens.

Many are Called, Few are Chosen

In this book, we have attempted to give an outline that spans over tens of thousands of years. It is a history or an idea that 'secret societies' have expounded ever since their conception and that 'science' cannot help but to stumble upon every once in a while. There was a Spiritual Catastrophe, a time paradox of the eternal return and a cosmic struggle that is still being fought today.

Why does the US Navy have one classified Arctic research mission after another? And what of the obliteration of the ancient Mesopotamian culture, implemented without hesitation during the last Iraq invasion for the eradication of that Aryan heritage in which museums were sacked and thousands of years of archives were burned. Or the mysterious phenomena of underground explosions causing earthquakes, etc.? There are things going on that we do not know, but more is surfacing all of the time.

The Hopi have a legend that says when the Blue Star Kachinas (ancient Aryan Spirits) unmask themselves before the public, then the time of the Great Purifier is near. This legend has nothing to do with the masked Amerindians who dance at the plaza and the Elders know it. What it is – is a time when matters become so corrupt that the very guardians of hidden wisdom begin keeping out the rightful Heirs of such knowledge and ability. The Eagles are waking up to find that they have been plucked of their feathers. The displaced Heirs, just as Adolf Hitler was, are being initiated by the Good God, Himself. They are scattered throughout a sea of ignorance and are few and far between. It is they, feeling the sting of betrayal better than anyone, who are laying it all out for the world to see, for they haven't made and are not compelled by any oaths of secrecy. To the world of men they are exiles, but to God they are the future.

It was not Zeus or Jupiter who went against Mallona, causing our predicament, for Jupiter and Mallona are 'together on all things'. This time paradox that we are living is the result of the true original sin, which took place when the 'Sons of God fell', trapping the Aryan Spirit in the material body. It was those 'Angels' who betrayed their leader, just as in the story of Quetzalcoatl, that of Adolf Hitler and a score of other histories.

It is always the same for those who cannot accept that they have failed. Their rejection transforms into hatred until they forsake the greatest quality they possess: loyalty. This is the great betrayal that echoes throughout the ages. The recurring themes that time and again surface in the eternal return, such as miscegenation, are the events that caused the original spiritual catastrophe.

And here it is Kinsmen, most of us have already failed. This writer knows that he has failed the Hyperborean Mythos in many ways. He failed it long before he realized what it was, but he will, nonetheless, fight for that Heroic Ideal anyway. Do we hate the leader for our rejection or do we fight for the one to come? Master Serrano speaks of it when discussing Parsival's initial failure. Parsival must go on without God, the warrior who has been stripped of everything, but a broken dream and his fury. Tolkien captures it beautifully in his epic *Lord of the Rings* – Aragorn is dejected when the Ringbearer leaves him and utterly frustrated by a seemingly failed mission. The only thing left to quell his hurt, his rage, the only thing he still knew was to fight the enemy. It is that crucial moment when one must choose to remain loyal and it is the soul wrenching question that most of us will have to answer.

There is an Irish legend that says the 'Little People' were sent to earth for not being willing to fight in the Great War of Heaven. While it is a legend, there is still a certain truth in it, anyone who has failed the Good Leader deserves to be in this world. The hard truth is that we are the crucifiers of the Christ. We are the blind Hodur who has been misled into killing his own brother, Baldur the beautiful. Do we not think that the Fuhrer spoke those same famed words of Christ on the behalf of the British and American soldiers 'Father forgive them, for they know not what they do'? We know he did.

The legendary S.S. Officer, Leon Degrelle, told Serrano that towards the end of the War there was a conspiracy to replace the Fuhrer (which Degrelle had no part in). The science fiction writer and ex S.S. soldier Rudolf Mund told Serrano that he was a part of that conspiracy; Mund failed the ultimate test - to fail and remain Loyal. The true S.S. Man remembered his motto (My Honor is Loyalty) and although left behind, he fought all the

harder and just as Parsival and Aragorn he achieved his Destiny in the end. It is the Ultimate Loyalty and that which separates the men from the boys.

This is the first group of Heirs - those who know they have failed, but fight for that which they know to be right anyway. Oh, what a freedom to shuck off any thought of consequences or achievements because all is already lost. The only concern is to use that rage of rejection in service of that which is True and fight the enemy who is the cause of this world of hypocrisy and lies in which we have failed. In other words, to hurt the enemy as he has hurt us. To fight for Heaven even though we have no place in Heaven, because we will not knowingly betray that which is true in order to follow the false. To take this justified anger and bitterness of a world gone wrong straight into enemy territory because he has nowhere else to go since sanctuary, just as Heaven, is closed to him. He can defend it, build it and even inspire it, but he cannot be a part of it. As long as there is War, this warrior will find no lasting sanctuary.

It is a feeling that cannot be described when one accepts this position. He fights for a dream he may never attain in a land of wickedness. He is a force that is very hard to stop because he still has his 'Ich'. In his 'long dark night' that sacred fire still burns and turns in his lonely heart that knows only to keep fighting and yet also knows that somehow, somewhere, someday, he will truly be reunited with his Beloved. It is possible that this noble outlaw is the one who is most like God, for God also refuses to retire to His chair as long as there is work to be done. The degenerates do dread an encounter with this straight shooting sonofabitch, for he wields justice.

It is the Dance of Lord Shiva - and Wotan awaits them, for there are still a few seats reserved in the Hall of the Heroes. Valhalla *calls* to them from Asgard and Mount Meru smiles upon them, from which His spear reaches to the Nail star and His entourage (zodiac) ever circles for the tomorrows.

And yet there is another revelation in all of this. A much higher understanding that can almost only be reached by failing. A realization that washes away all false pride, pettiness and ignorance. The realization that it has always been between God and you. What others do is actually of small importance. What is

important is to be of service, which is, to *give*. This awareness is the greatness of both Lucifer and Jesus Christ, they both gave all. To give of and sacrifice thyself for the sake of one's brother is the greatest love of all. And the poor actions of others mean very little because we are 'winning by losing'. Every single one of our thoughts and actions are sown into the raiment of cause and effect. It is only the 'beautiful loser' who really understands this truest science of the soul. This is the secret that the great Saint Francis understood and what Master Serrano confirms again and again by 'losing to win'. This is the wisdom of the richest wealth of the soul and leads to the complete liberation of the *chosen* one. His awareness and obedience to the wishes of God, which is, being true to one's 'self' have freed him from the chains of material ignorance.

"Through his evolving awareness, and his awareness of that awareness, he can merge with the miraculous — to which we can attach what better name than "God"? And in this merging, as long sensed by intuition but still only vaguely perceived by rationality, experience may travel without need for accompanying life. Will we then find life to be only a stage, though an essential one, in a cosmic evolution of which our evolving awareness is beginning to become aware? Will we discover that only without spaceships can we reach the galaxies; that only without cyclotrons can we know the interior of atoms? To venture beyond the fantastic accomplishments of this physically fantastic age, sensory perception must combine with the extrasensory, and I suspect that the two will prove to be different faces of each other. I believe it is through sensing and thinking about such concepts that great adventures of the future will be found."

- Charles A. Lindbergh

Mr. Lindbergh knew full well that his statement was only scratching the surface of what is the true destiny of man. This is the way of Hitler's Final Battalion that survived the Second World War and it is an absolute, Spiritual path. A science or magic of the still undiscovered ways of God. A straight path that leads to the God man or a proper son of God. It is a road made hard because of the many pitfalls, which are, the endless

distractions from our true purpose, the distractions that cause most to fail their mission. Those who are divinely inspired have been advocating this path for as long as one can remember. It is the path of the Hyperborean Ideal and it is through idealism that this road is found, in short, a saintly or heroic ethic. One must be willing to fight for that which they believe in. This ideal has had many names, such as, Martyrdom, the Graal quest, National Socialism, and Cosmotheism, to name a few. Jost Turner, who claimed he was no writer, expressed it well when he wrote, *The Essentials of Wotanism*:

“Wotanism, also known as *The Path of Wotan*, stems from the last Golden Age of this earth, which ended long before recorded history. In those enlightened times, our Forefathers were very highly evolved – even beyond the need for technology or instrumentation – and they understood the true nature of matter and spirit...Our Forefathers recognized that ego-consciousness is the key factor which limits the evolution of the individual, while its opposite, idealism, opens the door to higher consciousness...”

I am not sure if Turner even fully realized the significance of those prophetic words he wrote. What he said indirectly is that we *need* to become Spiritual beings in order to combat the enemy’s technological nightmare. The Aryan Spirit of goodness is on a higher frequency than that of the earth. In other words, if you are walking with God then cameras on every street corner, surveillance drones the size of insects, machines that effect brain waves, etc. are of little avail to the enemy because the all-knowing is on another level and sees it before it happens – we know when to be still, when to move and act and so on

Most men of action have had experiences when they knew that they had been ‘helped’ and that there could be no logical explanation for the life saving or game changing miracle they had been witness to. Or that little instinctual voice that we all have which never steers us wrong.

Now if one can imagine living every moment in this way of God consciousness, then one can see how easily the materialists could be defeated. And yet there is a science to it all for those who are dedicated and it is on a higher frequency than rational

thinking. The Hitler's loyalists discovered this nearly a century ago, for they knew that there is no beating the enemy with logic and rational. Not that it isn't possible to beat them at their own game, but who would want to, for the cost is too dearly for those who have their honor, therefore, nullifying the victory. Our struggle is a struggle ever upward to our star, which is, reached only through obedience to our inner voice and there is nothing 'rational' about it. In *The Edda – Key to the Coming Age*, the Arman Master Peryt Shou tells us:

“The Edda says that only the Valis and Vidars will remain in the new world. These are the ‘elect’ and ‘reborn’, who are obedient to the spiritual radio-network that will transform their bodies into arks which will save them.”

This work is for the one on the path of the total man or ‘superman’ and only they will be able to appreciate much of its message. A message that begins in silence and continues in self-discipline or ‘will to power’ and ends with complete liberation from the chains of materialism.

It does not matter what name we call God by. If it brings out the best in you (know the tree by the fruit it bears), then give yourself completely to that which feels right to you. They all have their own courses which lead to the Godhead (some more directly than others, but the Archetype can always be found). One is looking for that place which the Zen Buddhist is trying to find within himself, from there God's creation is revealed and all is made possible. The absolute man who has broken through beyond time, space and gravity, and is a ‘will to power’ most helpful in the service of his people, who languish in this cosmic struggle. Be a Hero of God!

God wields His Flaming Sword through the hand of this Warrior Priest. For His Sword is the Sword of Truth that echoes and resonates in the Soul. He activates the Ancestral Blood Memory and the Sleeping One awakens to sing a Hero's Song of the Mythos beyond time that will save our very Souls, in Truth, the only Myth that has ever saved our Souls reinvented time and again by the Good God. In this story He delivers to us an Aryan ideal that is the key to our salvation. He says, “pick up your

Cross and follow me." The only way we win in this world is with our Honor. The life and testimony of Adolf Hitler has taught us that again, he is truly, a savior to His people. The mountains of lies by lesser men will not change that fact.

So, for the man of the future, his initial battle is the one within himself. Once he succeeds in overcoming himself then all is made possible in the struggle for the liberation of his people who suffer the sleep of death in a sea of ignorance.

Lindbergh really said it all when he said "through his evolving awareness, and his awareness of that awareness, he can merge with the miraculous". Christianity knows this as the Transfiguration, the true Vimana. A 'paranormal society' of today may refer to this phenomena as the orbs of light.

Master Serrano explained it like this:

"A *Pulsionary Idea* that is achieved and maintained for a certain time in a *very high tone of soul*, until one is suctioned by the *Implosion* of the Black Sun, by the rotating of the Leftwards Swastika. And what submerges in the Implosion, reaching the *center*, is absorbed by this center, by *His Center*, defeating gravity, overcoming the velocity of external light, disintegrating oneself; but not losing one's identity or spiritual key. When the molecules disintegrate this key still remains. This key is the *Selbst*, the initiate *Oneself*, the person transmuted into *Personality*. Here we have the *Avatar*, and the *Resurrection of the Flesh*, converted into perishing matter, red, immortal *Vajra*. Here we also have the U.F.O. – the *U.F.O. Man*, the *Vimana* of the War of *Mahabaratha* and the last days of the Second World War. Here we have the *Flying Saucer* rediscovered by the *Fuhrer*, Adolf Hitler, and never used as a weapon of War..... He triumphed because he had conquered himself, the temptation to victory in an untimely moment, not chosen by Him, but by the Enemy. He won inside, not outside, within *Himself*, in the Inner Earth, Parallel, with *Implosion* and with the *Vimana*. More than this cannot be said, because one cannot explain everything. *If everything is explained, everything ceases to be...*"

What can one add to that? Other than to say that this liberation is the true destiny of man in which Hyperborea is

realized here in the present. The seed is within us and once discovered, it needs nurturing and time to grow and mature. The enemy is always striving to prevent this with endless distractions to keep the sleeping souls in their slumber. We are destined for the starry Heavens and the Golem can thwart God's plan only as long as he allows it. He allows it because we must earn our way back home. The 'Man to come' will cast aside the demeaning sideshow of the Dark Lord and liberate the earth as he liberates himself, for that is his mission.

Let us try to sum it up - one day history will find that Rudolf Hess was true in everything he ever said, even his amnesia was legitimate. To not remember is an intuitive gift from the High One that each one of us possesses. This writer honestly cannot remember what he wrote in the last chapter. It is one of the White God's great defenses against the enemy. To remember is to be going home and those who are going home came with the Stone.

The Stone which fell from Heaven, the Sun which fell from Heaven, the Son of Heaven. The first when She fell. The second when He came in search of Her (or visa versa). He fell, but not in the sense that the 'slaves of Atlantis' would lead us to believe in their seemingly endless quest to distort and confuse, to beguile the children. The Light was not cast here as an 'enemy of God'. It was voluntary in His search for Her. *He is the Hero!* And every bit of chivalry, dignity and nobility in this world arrived with Him.

Thus, the Aryan Spirit made its appearance. And soon began the 'civil wars' between the degenerated spirits who clung to the illusion and the new man, the God man, who dwelled in the consciousness of Light.

The doom and riddle of this earth shall not be solved until He has his She and the great wrong is made right. We have already won the War because we fight for more than our mere existence, we fight for the one to come. Better yet, we fight for an Ideal, an Ideal that the 'slaves of Atlantis and the children of mammon cannot comprehend.

General Douglas Macarthur said that the Third Great War would be fought in space; he was correct. It is already happening. Our governments and military, with the use of

mislead tools (fools) of Aryan descent, have manufactured and put into space 'U.F.O.s', but they will ever be a few steps behind the Hitler Loyalists, because the best which they can do is contemplate that which they have stolen.

One must understand that the world of today is still living on the coat tails of the Third Reich. Not only did they obviously invent space travel, but also computers, major highways, smart bombs, Grey's anatomy, social services and so on. Presently, the disinformation agents have people believing the silliest things of where all these technologies came from, but it was just those 'evil old nazis' the whole time.

Adolf Hitler was the Light that shineth in the darkness, but the darkness perceived it not. As the Aryan began to forget his glorious past, the Sacred Symbol of light and life was raised anew and consecrated by the Fuhrer, who came into the world to remind us of our eternal mission and destiny. Let us leave the demon of ignorance behind and step forward into the AllFather's Light. It is the Light of the Total Man who has been liberated. It is the Path of Wotan. The path of the true National Socialist.

Those who stay are here for the duration of the cosmic struggle, because they will not leave the Leader and He says we will fight for the Ideal, we will see the new Dawn. We will not forsake Truth nor Honor. We shall show the Prince of Shadows his error, for we will not abandon our Comrade. And even if it should take until the end of the world, we will save True Love.

We ask only for the strength and courage to better serve through the long dark night, ever preserving that Honor which God put into our hearts. So that when the morning light finally comes we may hold our heads high knowing that we served our God well and fought faithful and true for the Ideal. The Ideal that was put into form, into the form of Adolf Hitler. Truly, a Saviour to his people – a prophet of salvation and the only possible future for mankind.

And no matter how outnumbered we may appear to be we still have something which they can never duplicate: our Soul, our God. To have His Spirit is worth so much more than all of the world's distractions. He is our heart of hearts and relates to the Noble Soul that some things are worth fighting for – worth dying for. A great Gift it is that we have been given, a Gift that

55 Club

we are willing to charge the very gates of Hell to defend. Yes, with the clear conscience of a pure heart, we will face the darkness. A darkness that has always been our Destiny to overcome. Piercing the Heart with a Lance of Light, the clear waters of salvation pour forth. The Heart, which is the Center of the Cross and makes *Five*. So, tighten up your bootstraps, Comrade, because *things* are just getting started - *again*.

'Appendix'

"You all need to throw away your St. James Bibles and read the Vedas. Just like the Nazi's did before you." - Jack Heart

The great Initiate, Miguel Serrano, was one of the most honest and sincere men that a soul may ever meet. Well educated and a seasoned veteran by experience, Serrano would pave the way for a 'new religion'. A religion or ideal that will one day once again shower upon the world of men.

In the same manner as the Avatars who have come before and changed the world by re-instituting the sound doctrine of the Archetype, it is inevitable that Adolf Hitler will eventually take his rightful place among them. It is worth noting that the followers of Jesus Christ were reviled and hated for the first few centuries of their mission. It was their willingness to suffer and die for their Leader's Ideal that made Christianity unstoppable. Serrano is the great Apostle of Adolf Hitler.

A resident of Santiago, Chile – Serrano's native language was Spanish. His works are being fervently translated since his passing, for they were written by the hand of a Master. The first book of his epic trilogy was titled, *The Golden Cord*. His introduction to that work was simply fabulous and says in about twenty pages what we have attempted to outline in the last two hundred. We are grateful to now present that introduction.

Introduction to The Golden Cord

WHAT THE MASTER TOLD ME

It seems as if the years have not passed by but they have. I don't feel as if I have gotten any older. Slowly but surely, I am writing these books as if someone has been guiding me. But it's time to bring to the public the information that I have known now for the last thirty years. It concerns the last World War, World War II. This war signaled the end of times both in heaven and on earth. When the war ended thirty two years ago, it was easy to talk about what one thought because there existed freedom of speech.

Today the atmosphere is dense, we are being strangled and suffocated by the chains of the victors and the Light of the earth has faded away. No one will dare say what they know or could talk about up until five years after the end of the Second World War. Children born in these modern times have weak spirits, they are prejudiced by Communist Indoctrination in our very schools, by the constant Communist propaganda from our public schools, popular media, from the influx of drugs, from the constant preaching of "Universal Love," the drugs, the final music of Lemuria and so-called Terrorism coming from every corner. All this comes without any Celestial Light from the Gods. In the absence of Light, from our common sense, or from our Subconscious, or even from our Super-Conscious we have no contact with the Light of TRUTH and in the middle of so much Communist propaganda and access to only Communist literature and books our children become weak and absent of Divine Light. For those who are considered "Politically Incorrect", or are Political Prisoners, or are victims of some kind of torture from this Communist world, I give this Revelation.

ADOLF HITLER WAS AN INTIATE

Neither in heaven nor on earth did I ever imagine coming into contact with my Master nor did I expect to get Initiated, but I did. After becoming Initiated I have never left the Path even though it was difficult at times. It is a Warrior-Magician's Order. My Loyalty is to my Master for life and even the Afterlife. It was our Master who put us on Hitler's side during the Great War. The Master told me: "Hitler is an Initiate, you can communicate with him on the Astral Plane. I have no idea who Hitler's guides are but I have decided to help him. Adolf Hitler has an unbreakable Iron Will and he will follow any Order given to him. I have been in contact with him. The other day he told me that he has a mission to trigger destiny, to give the Earth the impulse necessary for its transfiguration and that He was the Vehicle used for such a purpose. When he was Initiated he was infused with 'Vril Power,' the energy of Hvareno or Farr which gives him the power over all the elements (wind, water, fire and earth). For that reason we must all help him. The next war will

be between Gods and Demons. The war will be a Celestial War, an Astral War, a Psychic War. It will be in Heaven, but the results of this war will be seen on Earth. Each one of us must help in our own unique way. I print a magazine called "The New Age" and in this magazine I try to educate the people and the masses. Twenty years after World War II the Nuremburg records were opened to historians. What a surprise they found! However, the real secrets and the TRUTH of course will not be revealed to the public and the masses. It was confirmed that the Master existed. When the book, *The Morning of the Magicians*, by Luis Pauwels and Jacques Bergier, was first published it created great curiosity and dismay even for the Communists. At that time I was Chile's Ambassador to Yugoslavia. The Secretary General of the Chilean Socialist Party, Raul Ampuero, friend of Hector Barreto, the "Jason" of the "Nonexistent Flower," talked to me about the book in Belgrade and informed me that the book mentioned "Esoteric Hitlerism."

A While later the Rector of the Chilean University, Eugenio Gonzalez, an elect spirit, profound and clear-minded, also a Socialist, talked to me about the book, *The Morning of the Magicians*. I reminded him that twenty years ago in my magazine I had already provided and discussed the information that this book is providing now. How was it possible that I knew this information Twenty years ago? The Master has always been right. He informed me five years beforehand what the Destiny of my country, Chile, would be. Chile would fall into misery, but would slowly come out of misery and become one with the most prosperous Nations in America. During the moments of misery it is hard to see a Land of Plenty, but my master has never said anything that did not come true. Confirmed by the stars and by our Destiny, we can never give up our positions, our own unique roles, and we cannot retreat and hide when the Celestial War of the Worlds begins. And To the war I owe my Initiation, to my Master I owe my knowledge of Esoteric Hitlerism. My Master never changed his mind. If he would have changed his mind I would have firmly Obeyed. But he didn't. He never told us we were wrong. When they opened the Nuremburg files, French writers began to publish books in the same style as the, *The Morning of the Magicians*, but they were full of lies and half-

truths. They were never translated into other languages except Spanish. The Anglo-Saxons (England and North America) ignored the truth because they did not want anyone to suspect anything. We cannot count on the Germans because the enemy's foot is right on their throat. They are being indoctrinated and constantly forcing the new German generations to forget their past, their history, their Traditions. We cannot count on the Italians because they will never be free of the Vatican. Everyone is being pushed toward Marxism and Communism, this is the real "Son of Man."

HOW ADOLF HITLER REALLY WAS

Adolf Hitler is one of the most peculiar individuals in the history of our Earth. If there is any doubt whether Jesus Christ was actually born or not, there is also doubt whether Hitler died or not. There is nothing in contemporary history outside of the Jewish Bible which confirms the birth of Christ and even the very people in the Bible who said that Jesus existed had never seen him personally. On the other hand there exists countless eyewitness accounts of people who have seen Adolf Hitler and who have actually touched him. Those who have seen him in movie theatres have described him as someone from another Planet, a Celestial being. During my 10 years in India I saw yogis, mystics, magicians—men who don't seem too normal, but they all look human. Even my Master looks Human, "All Too Human." Adolf Hitler is not human. He is way above the human race. Adolf Hitler is not from Earth. My first impression of Hitler occurred many years ago while looking in a glass window within a store on a street in Santiago, Chile. I was looking at a photo of Adolf Hitler. My first reaction was to turn away, but if you keep looking at his photo he will be Transfigured. Those who knew Adolf Hitler such as Otto Skorzeny, Leon Degrelle and Hanna Reitch all gave contradictory impressions of him proving that no one really knew Hitler (except for Rudolph Hess). Adolf Hitler appeared differently to different people - always hiding his secret. Except for my Master who was able to see him on the Astral Plane where no one can hide the Truth. My

Master's description of Hitler was that of a person with an Iron Will, he was a Ray of Light from another world with sufficient energy to transform the world. Hitler was a naturalist, a vegetarian, and he refrained from sex. We could compare Hitler's relationship with Eva Braun with the relationship between Jesus and Mary Magdalen. The Spiritual Wife of Adolf Hitler was not Eva Braun, but someone else – just as the first wife of Adam was not Eve, but Lilith. In each case the second woman brought corruption and treason. It is known that the stars and cosmos abandoned Napoleon when he abandoned Josefina. There is a universal cosmic law that there can only be one Spiritual Wife for each Master or cosmic hero. If he abandons his Spiritual Wife the stars and cosmos will abandon him.

HOW IT COULD HAVE BEEN

At the start of the war my Master told me: "I have seen Hitler's armies invade England. They arrived at the royal palace and they arrested the King." This event was written in the Akasic records of the Universe. Therefore it should have happened. It was cosmic destiny. Why did it not happen? Today we know that Hitler ordered his generals not to attack the British soldiers trapped at Dunkirk trying to withdraw back to their mainland. Who convinced Hitler to change the course of history? In the book, *Unknown War*, by Skorzeny, Admiral Canaris was a traitor. Admiral Canaris was in charge of counterespionage of the German Armed Forces who influenced Adolf Hitler through the son of Haushofer who in turn influenced Rudolph Hess. The argument that was used not to invade England was the "Hyperborean legend." England was Aryan, part of the Hyperborean continent, the land of Merlin, of the Holy Grail, Knights of the Roundtable, the Alchemist John Dee, the land of Angels, the land of the sacred Thule. Hecatee de Abdera, 400 years earlier referred to the British Isles as Hyperborea and Stonehenge the temple that was erected to The God Apollo (God of the North Pole, Thule-A-POL-lo,) who visited Hyperborea every 19 years when the stars completed their revolution. England was the maritime power of the White Race and Germany was the Land/Earth power of the White Race.

Therefore Adolf Hitler sent Rudolph Hess, an Initiate, to England to make a sacred pact.

THE ASTRAL BODY

This means that a person has conquered the energy and influence of the Cosmos and stars. This is a separate body that does not unite with the spirit. It is part of the Initiation. Masters and Initiates can project their Astral Bodies outside of their physical bodies and 'materialize'. Therefore some people can live Double lives while the rest of us live only single lives. To the common man, consciousness goes through the sequence of 'reincarnation' and the "wheel of eternal returning" - through a process of death and rebirth. To the Tulka (Tibetan doctrine), consciousness is everywhere including parallel worlds. My Master has seen Hitler in his 'Astral body.' Hitler has seen my Master also. My Master told me he met him on top of a mountain at a house made of rock. My Master peeked through the window and saw Hitler. Hitler then made a gesture to my master saying: "Traveler, continue on your journey." On another occasion my Master suddenly found himself standing right in front of Hitler and Hitler told him: "You will be able to see the return of the colonies but nothing more, I repeat nothing more." This happened during the period when Germany invaded France. I would meditate together with my Master to contemplate the meaning of Hitler's words. The next thing we heard was that Rudolph Hess flew to England and Germany attacked Communist Russia. Today we know that Rudolph Hess made an offer to England that Germany would withdraw from all occupied territories to the west, that England would be preserved intact, and she would retain her maritime superiority. The only thing Germany requested was the return of their colonies in Africa. Germany prepared for the great crusade towards the East, the Return of Asgard-Thule, all through the Caucasus Mountains. Germany was trying to recreate the Great Polar Circle of the Swastika. It was and is a symbol of the return to the great Solar Age and the end of Kaliyuga. For some reason this wasn't the right time for such a great miracle. What happened? Why did Hitler disobey the destiny written in the stars? Once I

talked to Skorzeny on this subject of attacking Russia. Skorzeny approved Hitler's decision. He said it was necessary. The pact that Germany had with Russia was too much for German leaders to bear. It was against the ideals of a racial Socialist State. Our Fuhrer also thought so. I insist that the timing for Hitler, was either too late or too early. It was too late because Germany failed to invade England and too early because Germany could not fight a war on two fronts.

I DREAMED OF STALIN

The night of the invasion of Russia I had a dream, but it was more like a vision. I saw Stalin standing on a balcony with his hand making a gesture to the crowd below as if he were a minister. I was impressed. I dreamt twice of Stalin during the war. The second time was at the close of the war and he was sitting with his advisors discussing the Vatican. A fact that many people do not know is that Stalin lived for some time in Rome with the Jesuits. Weisshaupt, the founder of the Bavarian Illuminati, also studied with the Jesuits. Lenin, another disciple of the Illuminati, used the tactics he learned from the Illuminati during the Russian revolution. On many occasions I do not need to see the facts or be present to know what happened. I remember one night after the attack on Russia I was walking along a street with my uncle, a poet, Vicente Huidrobo. As with most conversations we had we were discussing the war. My uncle was against Hitler. Suddenly he told me that Hitler is the only person in the world who knows that he has lost the war. He said this with such conviction that I knew he found out this information from some other source. It was the Masonic Lodge. This is where a world pact was made with world Jewry against Hitler. A fatal, irreversible decision was made which included international Masonic lodges, the Catholic Church, the Protestant Church, the Rotaries, the Red Cross, the Socialist Movement, the Communist Movement, the Democratic countries and the Capitalistic countries. Hitler had lost in the face of such great odds. This was accomplished because of the evil intervention of extraterrestrials which promote world slavery known as the 'New World Order.' My uncle had already told me that he

became a member of the Masonic Lodge. He had told me that if I played my cards right I could be part of this victory. My uncle had a rebellious spirit and didn't like to take orders. I knew he needed help. He tried to change his cosmic ID, his very Blood. When you try to do this you lose your identity with your race including your spirit. It's something like what happened to Hitler because he disobeyed a Cosmic Order. There is an impenetrable mystery of the relationship between Hitler and Tibet, Mongolia and with India. The India I am talking about is not the same India you know. What I am talking about is the underground India, the subterranean India. The Teutonic Knights and the Baltic Barons tried to find their way back to the Swastika the same as Unger Von Sternberg, as he writes in his book, *Beasts, Men, and Gods*. In 1926 Tibetan and Hindu colonies were established in Munich and Berlin. In the last battle at Berlin both Tibetans and Hindus fought side by side with the SS. It was the Tibetans who revealed the truth to the world about the evil Jews. It is also believed that the Tibetans are the guardians to the secret entrances to the subterranean world of Agartha and Shamballah where our great Hyperborean Leaders live. The truth is Shamballah actually means KAMBALA (KBL), which is the center for "Esoteric Hitlerism." Therefore, Adolf Hitler did not have direct relations with the Tibetans or Mongolians; the relations were indirect. The Tibetans and Mongolians provided all communications, entrance, and access to the submerged Hyperborean world. They were Hitler's loyal servants maintaining the secrecy of these worlds. Today Tibetans and Mongolians are slaves to the external world after the loss of the Second World War. There must be a good reason for this. When I visited Adolf Hitler's home in the Alps I could feel a vibration that connected me instantly to the Himalayan Mountains. There is no doubt this place was picked by "Esoteric Hitlerism." Hitler's mountain home had many underground tunnels. Anyone who goes to Hitler's home in Berchtesgaden will feel the difference immediately. We must remember that "Esoteric Hitlerism" also called this home Grailsburg, or in other words, the Grail's Castle. There exists geography and geometry developed during Hitler's Third Reich which purported to come

in contact with the underground portals in Egypt and this is still kept secret. The master, Adolf Hitler, was also an architect.

HITLER KNEW HE WAS GOING TO LOSE

Nevertheless, the new cosmic coordinates of destiny after the attack on Russia affected the universe. It was too late to reach our dream on Earth, to regain Hyperborea and to return to the Golden Age. Hitler now raises the bar and many followers might not have had the strength to bring this World War to a Cosmic level between Gods and Demons, between Light and Darkness, between Fire and Ice with rivers full of blood. He knew he would lose the war here on a physical level so he has brought the war to the new level -an Astral War. Hitler decided to lose this war in order to win on a higher level. On this physical plane he could not count on people who did not TRULY BELIEVE. They would automatically be recruited by the Demonic forces. Hitler would have won the war here on Earth if he invaded England. But he did not invade England and then England betrayed Hitler, therefore either Hitler or the Gods want vengeance. They want something much bigger. In retrospect to what my Uncle thought about Hitler, Hitler lost the war on purpose in order to return triumphant in the final times and to expose the enemy – International Jewry. Therefore, we must fight without giving up, trying to open the eyes of those who cannot see the metaphysical reasons for this war. To unmask the real enemy. The blood of our fallen heroes gets more blessings from God than those with wisdom or who constantly pray to God. The Gods know they cannot die and they admire the courage of heroes who do not know that they cannot die and volunteer their lives for a dream and a BELIEF. Is there anything more beautiful? This is the sacrifice most appreciated by divinity. Odin, or Wuotan, salutes the heroic death of a warrior. This produces great blessings on the Astral Plane.

HITLER IS ALIVE

The energy of Hitler and Germany was so strong it nearly won the war. My Master also saw Stalin and Stalin told him: "We

cannot go on any longer. We are up to our necks in water." But destiny is destiny. It will not change. Because of Germany's attack on Russia two crucial months were lost. Should Hitler have helped Mussolini in Greece or Yugoslavia? In two months he conquered both countries, but he lost both Countries during the Russian summer. It was a fatal blow. Then came the Normandy invasions and the invasions in Italy. It was during this period that my Master heard a voice that said, "Can you see how that woman who has all pervading power failed to get vengeance?" Who was this voice talking about? The next day the voice said, "The heavens have permitted Hitler to make a surprise attack." Not much longer we heard the news that the German offensive was victorious at Ardennes using the SS and the last available forces that Hitler had. With this victory Hitler almost changed destiny again. Leon Degrelle informed me that all was lost because the German tanks had no fuel and they failed to see the fuel that was left behind in the snow by the North American troops. During the Apocalypse, Berlin fell, and Hitler's underground hideaway was filled with flames and bullets. Celestial Music was played for the Heroes who had already fallen, but Hitler did not die there. He escaped far away. For many years Hitler had information about South America, he sent Paul Rohrbach to investigate. Hitler investigated Tibet, India, and Central Asia. Once again my Master heard the voice, "They were a victim of their own mental creations." My Master then saw a White Feminine Spirit who was separated from her native soil where she was born. It was a beautiful luminous spirit. My Master says that it was the Collective Spirit of Germany that has been lost. Today's Germany is different; they look like fat ghosts, materialists, a country without a soul. Many years later my Master revealed a secret to me. Hitler is alive. He did not die in Berlin. My Master saw him underground. He has changed and his Mustache is long. He saw him face to face. Hitler then turned around and disappeared into the semidarkness. I have not revealed this secret for many years and for good reason. Now I can explain my own adventures, my trip to Antarctica between 1947-1948 trying to find Hitler in the so-called Oasis of Warm Waters in the middle of the ice and the entrance to the subterranean worlds. During the war at the end of

1943 Admiral Doemitz made a public statement to the effect that the German submarine group feels proud in discovering an underground paradise, an impenetrable fortress for our Fuhrer. Where is this paradise? After the close of the war Stalin communicated to the United States that Hitler did not die in Berlin in his bunker and that he was still alive. The Russians never found the remains of Hitler. The body they excavated and removed from the ruins and moved to Moscow was not that of Hitler. Twenty-five years later Lev Besymesky published a book titled, *Hitler's Death*, with photographs and radiographs of Hitler's skeletal remains, which in fact did not match with Hitler's dental x-rays of Dr. Erwing Giesing. Dr. Merner Masor published a book in 1971 titled, *Last Name Hitler, First Name Adolf*, and in it he confirms that the remains of Hitler were never found. Adolf Hitler disappeared without a trace and so did Eva Braun. Otto Skorzeny revealed in his books the intense interrogations the North Americans put him under and the sequence of the questioning was always the same. "Where did you take Hitler?" "Where is he hiding?" A book that was published in Buenos Aires in 1946 by the pen name Ladislao Szabo, a Hungarian, revealed how Hitler was secretly transported to Antarctica in a convoy of German submarines to where Captain Alfred Ritscher discovered an oasis of warm water in the Queen Maud Territories in 1938. Captain Ritscher belonged to the German Air Force. But all his activities were kept secret. Therefore, the Hyperborean theory of the "Resurrection of the Hero" was transferred to the inverted Thule of the South Pole.

MY SEARCH IN THE ANTARCTIC AND IN THE HIMALAYAS

I can now reveal this information because the modern world of Democracy and Communism, which is one and the same, are already aware of this information anyway. There is nothing they can do to stop destiny and they were paralyzed in 1945. In my book, *Who Calls from Within the Ice*, I talk in detail about my trip to Antarctica looking for that oasis of warm water, and of course, the polar opening to the center of the Earth. In my book,

The Serpent of Paradise, I tell of my travels to the Himalayas looking for the Ashram of the Siddhas (Holy Men), also my search underground within Mount Kailas, where the Masters of my Master reside. Today I know that all these things exist and they are all connected to one star, the Morning Star, called Lucifer. One day a man came up to me and told me that the "Order" has connections and influence over the recent and past history of the world. The man just suddenly disappeared. The "Order" has also disappeared, into thin air. My "Master" has disappeared. Everything now seems just like nothing more than a dream. This is how I have been living lately, pursuing a dream. I am also a prisoner of ancient legends, a victim perhaps, of our own mental creations. We must wait for the return of the Celestial Armies, the Wheel of Destiny, when the Laurel will bloom once again. All the "Initiates" are saying the same thing.

THE HOLLOW EARTH

Before entering into the arguments and theories of those who believe in the Hollow Earth I would like to say that I see this as a "Reincarnation" of an old legend or idea and the scientific explanations only come second. Like all ancient legends this theory is also directly related to the ancient Hyperborean legends where everything occurs at the poles and where we find our solar and polar heroes. The resurrection of Hitler also occurs within the poles and from underground and within the warm waters of the Antarctic. The Flying Saucers are also related to all of this. This book centralizes on the theme of supreme ambiguity where **ANYTHING IS POSSIBLE**, that whatever happens in Heaven also happens on Earth. Therefore anything is possible because ancient legends repeat themselves over and over and materialize themselves over and over again. Therefore no ancient legend can be negated, not even the theory of a "Hollow Earth." We cannot negate the survival of Hitler, and we cannot negate the existence of Flying Saucers. We cannot negate these things because they all had their origin in ancient Legends. We must realize that a lot of symbolism is used to represent beliefs and Doctrines, thereby demonstrating a duality of spheres. This is where plasma gets its power, and materializes on the Terrestrial/Earthly plane. This is

the magic, the Power, the reasoning behind it all. The same year that I traveled to Antarctica, looking for the secret entrance to the Hollow Earth, Admiral Richard Byrd of North America went to the North Pole or "True North" as we put it. The Earth curves inward at the two polar extremes whereas if anyone goes farther than 83 degrees latitude they will find themselves inside the planet. The force of gravity is contained in 800 miles of crust beneath the surface of the earth. After 800 miles there is only air and the Hollow Earth. The surface on the inside of the Earth has continents, seas, forests, mountains, and rivers inhabited by a superior race that moved there in ancient remote times directly related to the Hyperborean legends. Their technology is light years ahead of ours. This superior race maintains contact with selected people on the surface of the Earth. The cities of Agartha and Shambala exist there. (Agartha means "not-accessible" in Sanskrit and is related to the Nordic home of the Gods, "Asgard" - Home of the Aesir). All the spiritual leaders of the Templars, authentic Rosicrucians, and Esoteric Hitlersim go there for their instructions. Hitler receives his instructions from them. They permitted Admiral Doenitz with his sailors to enter inside navigating under the polar cap into secret passageways. (In the Antarctic the Caleuche, the mythical Ghost Ship of the South Pole, entered and exited with all of its lights on beneath the icy waters and was crewed by dead men - In the Arctic the ghost ship Wafeln entered and exited the North Pole) Gypsies and Eskimos were not permitted to enter. The Eskimos have a song about the people from the interior of the Earth and say that they are terrible. The climate inside the Earth is of a fair temperature all year round. In the center of the Earth there is a sun. It is smaller than the sun we know of. Since there is less force of gravity in the interior of the Earth the people grow much taller and they live much longer. It gives the impression of eternity, a miracle, heaven itself. My master has told me that the 'Temple of the Order' is found within the Hollow Earth and has a permanent beautiful white light that is not produced by electricity. The first people to start writing about the Hollow Earth were North American authors Darwin and Erasmo in the book, *The Golden Secret*. The Druids also knew of the Hollow Earth.

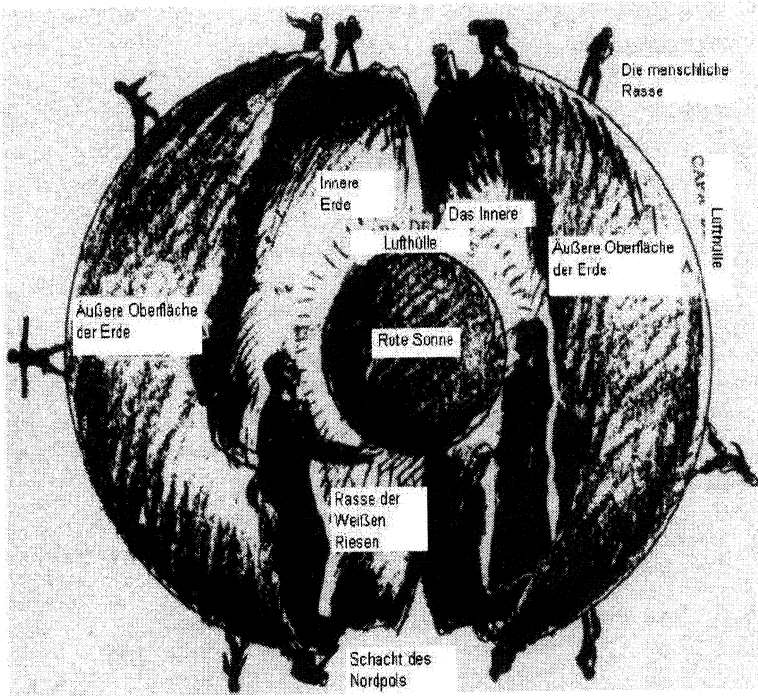

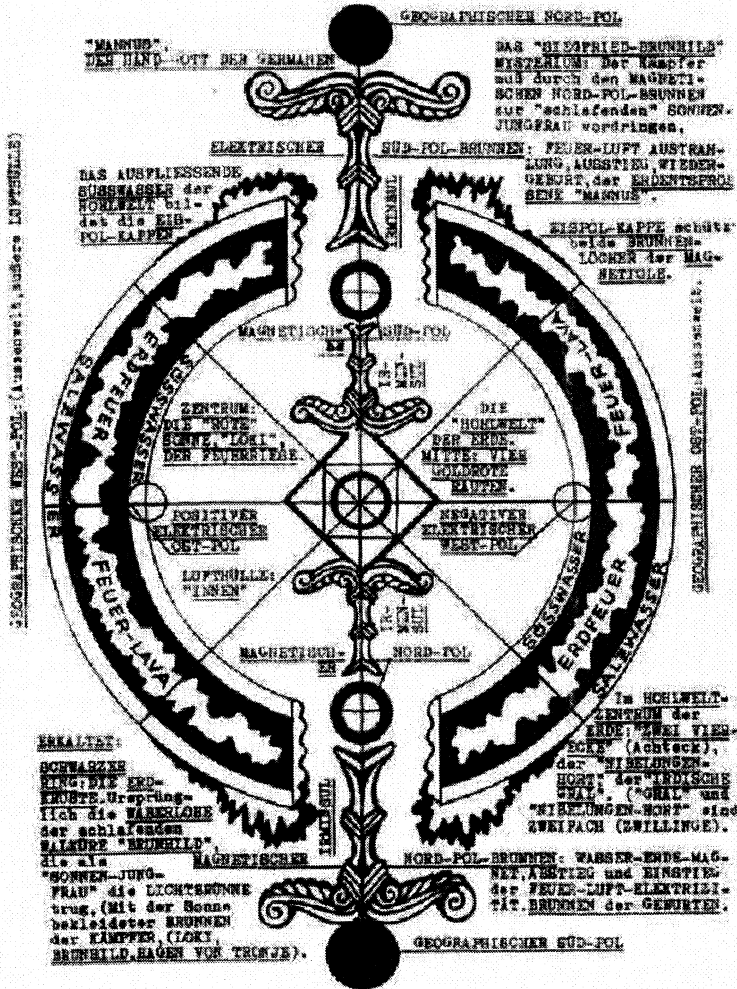

THE PHANTOM OF THE POLES

In 1906 William Reed wrote the book, *The Phantom of the Poles*. In that book he says that the Earth's crust is 800 miles thick and the Hollow Earth is 6,400 miles in diameter. The openings at the poles have a circle of 1,400 miles. Mr. Reed maintains that the so-called poles are a Phantasm because the Earth has openings on each end of the planet. The Earth is not a sphere. In reality the poles are in the middle of the air at the center of the openings found on each end of the Earth. When explorers tried to find the North Pole, their compasses would go haywire. After reaching latitudes 75 to 76 degrees, north and south, the land begins to curve inward. On the surface the pole would be the same as magnetic north closer to the polar opening. The magnetic north pole was believed to be along the Arctic Islands, but the Soviets have defined magnetic north as a line 1,000 miles long ringing the opening at the pole. When an explorer has found the opening then he has found the magnetic north pole. Even if the compass continues to mark north as you continue forward it is not a true reading. When you pass the latitude indicated the compass turns upward. This is because you have entered the opening and the compass continues to mark magnetic north which is at the border of the opening. The true North Pole is in midair which is a phantasm. Once you enter the Hollow Earth you don't realize it because even though you are in an inverted position you feel as if you are on top of land. This is because the force of gravity emanates from the crust of the earth. A sailor of the seas knows he is navigating the globe in a circle, but all he sees is a direct line and the same happens with a pilot. If an explorer wants to know where north is or where south is after passing the latitudes mentioned, then he better turn back towards the border of the openings until the compass begins to work again. Otherwise we will continue into the Hollow Earth and investigate a new universe. Is this possible? Would we be allowed to encroach upon another civilization? The Aurora Borealis is the reflection of the sun and the dream of the Green Ray from the interior of the Earth. The rays emanate from the openings at the poles. This is why the planets Venus, Mars, and Mercury shine at their poles. They are also hollow inside. The

icebergs freeze in the rivers inside the openings then float out into the ocean. This is why we have fresh water icebergs in the ocean. Another North American writer published a book in 1920 titled, *Journey to the Center of the Earth*. The author, Marshall B. Gardner, argues that the central sun inside the earth is part of the original creation of the world and that this is a principle upon which the universe was created. The rotation of the planets and the centrifugal forces pull the greatest mass outwards. As we can see the largest planets in our solar system are also the farthest away from our sun. This means that these worlds are being thrown farther out by their centrifugal force because of their mass. This mass forms the outer crust of the planet. A central sun is formed on the inside of the hollow planet. The greatest mass is found at the central line of the planet, which we call equatorial lines or the equator. If the world was originally just a ball of fire of molten metals, the fire would continue to burn on the inside while the centrifugal forces would cause the mass to cool and form the outer crust. This internal fire would become a sun providing light to plant life, animal life, and human life. If there is any doubt about the force of gravity as to the possibility that one would automatically be drawn into the center, Gardner reaffirms that the force of gravity comes from the outer crust of the earth and not the center of the earth. The center sun is found 2,900 miles into the center of the Hollow Earth. This same force of gravity will keep you firmly on the ground once you are inside the Hollow Earth. The common myth is that the planet earth is a solid sphere and at the center is boiling hot iron or lava. Forget this myth. If the outer crust is 800 miles thick then the molten lava would be 7,000 miles in diameter and 21,000 miles in circumference. The surface of the earth is 197 million square miles and it is estimated that the earth weighs approximately six-trillion tons. If the earth were a solid sphere it would have to weigh much, much more. This is the greatest factor in proving that the earth is hollow. The old myth is that the closer you get to the center of the earth, the hotter it gets. Forget this myth. The temperature only increases until you reach 80 miles down into the crust. After 80 miles the temperature starts descending. What produces the intense heat is radium and radioactivity. All the rocks and stone of earth contain some radium and some

radioactivity. The source point of all volcanoes is also found within the outer crust of the earth. The interior of the earth has a subtropical climate, therefore many of the discoveries made on the surface of the earth of certain vegetation or animals originally came from the interior of the earth.

ADMIRAL RICHARD BYRD AND THE SOUTH POLE

Military and civilian flights across the Poles do not see the openings because they think this is a geographical location and not some ghostly opening within a certain circumference. They hardly touch the outer border of the opening before they go off in a different direction. Admiral Byrd did find the opening. Admiral Byrd flew 1,700 miles into the interior of the earth in 1947 entering through the North Pole. Admiral Byrd saw land, sea, continents, and vegetation. He couldn't wait to go back and once again see such a paradise. Raymond Bernard PhD., a friend of Byrd and friend to me under very special circumstances, revealed Admiral Byrd's secret. It was Admiral Byrd's expedition which inspired me to go to Antarctica. On December 2, 1946 Admiral Byrd sailed towards Antarctica with an Armada ready for a major war. The ships were Mount Olympus, Capitana, Pine Island, the destroyers Brownsen and Henderson, the ice cutter North Wind, the aircraft carrier Philippine Sea, the submarine Sennet, fuel ships Capacan and Canisted, and the Cargo ships Yankey and Merrick. There was also another aircraft carrier named Currituck. The Armed Forces from other Nations were all arriving at Antarctica at the exact same time. No doubt this was a military operation and not an expedition. Who was the enemy?

Admiral Byrd stated that the Poles stood between them and the enemy. He made that statement on the 7th of June 1947 in Santiago De Chile. It looked like the Normandy invasion all over again. Who was the enemy?

Admiral Byrd apparently dropped a bomb into the opening of the South Pole and it was like throwing a rock into a beehive. Suddenly his planes were missing, ships froze, men perished and

died, it must have been a catastrophe. He went limping back to the United States. Later we only heard of his expedition inside the North Pole, and then there was complete silence, then came his sudden death. Ever since 1947 there has been a close watch on the Antarctic continent of some 14 million square miles. It is here we should ask if Admiral Doenitz, who was the Secretary of State under Hitler before his escape and disappearance, was tortured and forced to reveal Hitler's hiding place. The allies never believed that Hitler died at the end of the war.

Admiral Byrd was definitely after someone in the Antarctic. I also went to the Antarctic at the end of 1947 and the beginning of 1948, but I lacked the proper technical equipment to get to the opening or to the warm waters that are talked about so much, but I did receive ample input from my Psychic and Auric Antennas. It was the book, *The Morning of the Magicians*, by Jacques Bergier which was the first book to inform the masses that Hitler's administration was interested in the "Hollow Earth." Jacques Bergier, a Jew who belonged to the Intelligence Service of the allies during the Nuremberg trials found out about Hitler through the interrogations of SS men. The SS made the first experiments in radar in the Northern Sea and with this radar they found the "Paradise" for our Fuhrer.

THE FLYING SAUCERS

Very important statements were made by Ray Palmer, editor of the North American magazine "Flying Saucers." In an article published in 1959 he claimed that Flying Saucers come from Earth. He challenged a top secret. He claimed that the Flying Saucers do not come from other worlds, but come from a country from the surface of this Earth. According to Ray Palmer the Flying Saucers come from within the Earth and they began to appear in 1945 at the close of the Second World War (is this a so-called "Coincidence?"). They appeared as a warning to all the countries to stop the use of atomic weapons. The highly evolved civilizations from within the earth will not permit an atomic contamination of our planet. The national 'blackouts' of electricity that occur all across the globe without reason are

warnings caused by these civilizations that they mean exactly what they say. Palmer agrees with Reed and Gardner on the Hollow Earth theory. After this article was printed the magazine was never seen again. According to Palmer all the governments know this to be true but they want to keep it a secret from the public. The Flying Saucers began appearing in 1945. The greatest Concentration of Flying Saucers was in the Antarctic.

Isn't it curious that the whole world came to an agreement in 1959, the year of Geophysics, to place Antarctica off limits to atomic testing? While I was the Chilean Ambassador to India the Indian representation to the United Nations rejected twice the proposal to make Antarctica an international territory. I feel I had a part in this. In the summer of 1976 a new expedition was organized to explore Antarctica by 10 nations, called the "Ross Ice Shell Project." What they intended to do was to drill down under the ice for a quarter mile in the Sea of Ross to see if they could find a continent or if there was just water. Something mysteriously unexpected happened. The project failed and the project was suspended as soon as it started. All they said was that they would restart the project at some future date. Nothing works in the Antarctic. Space satellites don't work while passing over the Antarctic, neither do NASA flight missions except for the space Photographing of the openings at each end of the earth. This they do have. Raymond Bernard expanded upon Palmers claims and said that he has had contact with some of the people of these flying objects and they look like Germans and they speak German. Bernard claims that these people say that they are from another planet only to mislead everyone from the truth. But it is very possible that they might have bases in outer space. The principal Latin author of Flying Saucers, Antonio Ribera, claims that the Flying Saucers belong to the Nazis and they come from the Antarctic. Many UFO investigators believe this. A German who lives in Chile confesses that the Germans invented the Flying Saucer at the close of the war. These Flying Saucers will be piloted by all the fallen heroes in the final battle. Hitler swore that the last battle would be his for the taking.

THE PROPHECY OF JOSEPH LANZ

The prophecies of the Austrian Josef Lanz, or Georg Lanz Von Liebenfels, publisher of the Magazine "Ostara" and whom could be the first Initiator of Hitler in Vienna, during his "Secret Years" were in a number of these magazines published in 1912. Founder of the "Order of the New Templars" (ONT), He prophesied the legendary rise of Hitler:

"The Ases will return to conquer the City of Asgard in the Caucasians. They will be guided by the Valkyries and the Great White Horseman, the Incarnation of the Supreme Lord. They will return to the Sacred Osetia and the Magical Mountain, Elbruz." "After twelve years, after his true Initiation he will receive the first secret as to what this sign means, this knowledge will be your armor. After learning all the minor and major mysteries you will be selected to learn the 12 degrees of becoming a SONNENMENSCH (a Sunman, Godman, Superman), which will give him the magical powers he will need to accomplish his mission. Until that time he must pass the test of Fire and Ice (the War) within his own body before he may return to his disciples (only the Initiated) and appear in light in the Terrestrial realm. His Empire will go against the forces of evil (Elementals, semi-animal beings, the Sheidim of the Bible), and he will become the Supreme Lord of the Universe, in the City where they radiate the Great Luminous Revolving Cross. He will plant his Standard and Flag at the summit of the Mount of the Ark."

Hitler and the SS did scale and climb the top of Mount Elbruz in the Caucasus and plant the Clockwise Swastika before the march into Stalingrad, where they thought it was the Sacred Osetia, the legendary city of Asgard. Believers of the prophecy of Lanz thought that in the top of that mountain he would find the Power of the Magic of Hyperborea, of Hvareno, Vril - Victory. Repeating step by step the premonitions and signs. "Every 700 years the Laurel Blooms" is a saying of the Cathars. "Humanity advances one step every 700 years" said Hitler. "Every 700 years there is a fire offensive" said Horbinger. The Clock-Wise

Swastika represents fire. Every 6,000 years we enter a new period of ice. This is called the war of Fire and Ice. Having the true power of Odil-Vril, he will show his enemies the power of fire from the sky and they will serve him and he will have the power to bring more violence to earth than a thousand lightning bolts (Hitler had the Atomic Bomb, but never used it and it was stolen by America and Russia). He will be the Supreme Lord of the world and will restore 1,000 years of law and order. Hitler already had the Atomic bomb in Germany during the Second World War, but Skorzeny confessed that Hitler did not want to use it. Could it be that his Spirit Guides, the Hyperboreans of Agartha and Shamballa, would not permit him to use it? The North Americans had stolen the Atomic bomb technology from Germany. Then Lanz finished his prophecy:

“The Supreme Lord will go on a great trip. The Son will have constructed an Eagle made of gold and at the exact Sixth Age of our Supreme Lord he will be escorted to the doors of the Celestial City, they will be marked by 12 revolving black crosses that illuminate the Night at all Time”

(The Black Sun, Midnight Sun?). Behind Gotterdammerung, the Twilight of the Gods, the Center of the Gods, the Golden Eagle will return from the subterranean world, from Asgard/Agartha, the paradise of the Edda, from the Valhalla of Wuotan-Odin and the Valkyries where the Hyperborean Priestess Allouine resides.

THE MIRROR OF THE PRINCESS PAPAN

There are supposedly various entrances to the subterranean world. There is one in Tibet, in the Gobi Desert, Mount Kalias, there is one under the great Sphinx in Egypt, in Guatemala, Peru, Brazil, in northern Chile, the Polar caps, and the Andes Mountains where I actually have seen the giants. The Sphinx and the Pyramids are called the ‘Icebergs of the Desert.’ What this means is that what you actually see is very little in comparison to what you would find below and within them. They are firmly situated on top of subterranean worlds connected by tunnels and temples, old remote cities, so what we are really looking at from

the desert is the top of a mountain, the top of an Iceberg. What we would find underneath are cities which have been abandoned for ages—the pre-Egyptian ATLANTEAN age. There are also cities and worlds with inhabitants and more subterranean tunnels. John Dee, an extraordinary Alchemist and English mathematician during the 16th century said that the Earth was not round, but concentric at the Polar Caps. He said that according to mathematical calculations the Earth was not solid, but was a series of Spheres superimposed which made it possible to communicate between the Spheres. He tried to convince Queen Isabel of England to takeover Greenland because this land gave access to a Parallel Universe. John Dee received these revelations by concentrating on a Black Mirror, a Black Sphere, that is located today in the British Museum. It is said that John Dee could communicate with Extraterrestrials from Hyperborea, beings from inside the Earth and beings from Venus, the Morning Star. The 'Angels,' according to Dee, could pass from the present into the past or into the future. I have thought a lot about John Dee's Mirror in the British Museum. I suspect that was the Black Mirror of Princess Papan where she could clearly see the White Gods of Hyperborea. Those who have seen UFOs or Flying Saucers know that the Flying Saucer knew the thoughts within their minds. For the Disks of Light can read the "thoughts and emotions" of man and woman. This is because the Flying Saucer materialized from a parallel world. Therefore the UFOs are always present, but we cannot see them.

Fortunate are those who are able to see them!

If we fly up into the atmosphere 200 miles, satellite pictures will not show the topography of our Earth. If we were beings from outer space we would say that no one lives on this planet. Out of 250,000 photos of Earth taken by NASA, only one shows Earth as an inhabited planet. From this high of an Altitude the Astronauts have been able to see Lost Continents and Ancient Civilizations. The original inhabitants of this Earth were the White Gods of Thule, Hyperborea. They showed mankind civilization and put their Genes in the Blood. They came to earth from other worlds, maybe Venus, the Morning Star, in some

Ancient Age. They all lived in Thule, in the pure virginal white Polar Regions. When the first catastrophe occurred on the Earth, they went to live in the inside of the Earth. When the continent of Atlantis disappeared, those Masters who received the 'Hyperborean Initiation' joined the others inside the Earth. Many more are arriving who have been Initiated.

THE ASTRAL TUBE

The openings at the Poles are not only openings into the interior of the Earth, but they are also a window to other invisible and parallel worlds, the fourth and the fifth dimension. Through these dimensions one can enter and exit analog worlds. From these dimensions come beings from other planets and from distant stars, the Hyperboreans. Through these portals disappear the Masters. Through these portals UFOs and Flying Saucers travel to distant galaxies. This window to other dimensions can also be found in Kenya, Africa and in the 'Bermuda Triangle.' Through these portals my Master communicated with Hitler. Through these portals the UFOs and Flying Saucers do not disintegrate. Through these portals miracles happen and it is where the greatest discoveries have been made. Through these portals one can travel astronomical distances. The 'Exits' to parallel worlds and "Entrances" to the interior of the Earth vary according to cosmic and planetary cycles. Therefore, if an entrance were closed during a cycle a person would not be able to find the entrance psychologically. The entrance is there, but it is impossible to see or recognize. In the current cycle all the entrances and exits are located at the South Pole. The civilizations inside the Earth are superior to the inhabitants on the surface of the Earth. The civilizations inside the Earth consider the inhabitants on the surface barbarians, beasts, and they know what our destiny is. 'The New World Order' will be impotent against the power of the interior world. The signs are always present. If they weren't we would have had an atomic war a long time ago. The plan of 'The New World Order' is total destruction and dominion over the planets so that they can finally install their 'Messiah,' the false King of the World. But they are scared of the 'Last Battalion.' They try to keep it secret so that

the masses will not know and rise up and destroy their conspiracy. No matter what happens it will be catastrophic. One has to travel more than 1,500 miles inside the Earth to find the cities of Agartha, Shambala, and their giant inhabitants. You will not be able to visit them without their permission. You must know the proper signs to get through. Raymond Bernard has said that the superior race affirms that the Jewish Bible is only a concoction of lies and plagiarism. The superior race does not believe in sin. They believe in Hyperborean magic, it is the Order of Odin-Wuotan. Contrary to what we believe today the old civilizations of Thule and Hyperborea named the Morning Star Lucifer, is the origin of Masters, Angels, Avatars, and high civilizations. Souls such as Hitler travel from there to here on rays of light from Lucifer (planet Venus) to Evolutionize and Spiritualize mankind. Jehovah on the other hand is the "Lord of the Earth" which was considered evil.

Hyperborea is now in the South Pole, where the entrance to the center of the Earth lies. Now I know why my Master told me to be on Hitler's side during the war. In the south of our world will rise the Blue Spirit of the Polar Race of all the "Initiates" and they will get vengeance, and they will recuperate everything that has been lost. A few of us will be saved and this will mark the finish and finality of the Dark Ages of Kaliyuga, the Age of Iron. All of our legends have a universal value because their existence is on a cosmic level. These legends compose our ancient science. They disappear and reappear. They are Non-Existent Flowers and become more real than all the flowers of the world. For underneath the seas there exists a Golden Thread that connects all beings of the same race to one Spirit, one World, and it goes through all the continents and they have all been joined together since the beginning of time. Here no one can change during a conflict. All that exists is a brief rest at death. Because warriors live forever. This book is about that particular Golden Cord, that Auric Chain.

MY AMERICA IS THE LAND OF THE WHITE GODS

In the Polar Caps exist the exits towards other universes and outer space. Today the South Pole is the current active exit point. From the Polar Caps you can see the Morning Star, Lucifer-Venus. The Hyperboreans who came from other worlds settled at the North Pole, a connecting point to great astral currents. They enter and exit by using the figure eight. There they live where there is little oxygen and their blood is blue. Has anyone ever thought why the Indo-Aryan God Krishna appears as blue? In the Ancient Americas, Hyperboreans, known as the White Gods to the inhabitants of the earth, taught their leaders and made wise men and they sent some to Thule for additional instruction. The Earth is a living being. Each part of the Earth has its own magnetism and special vibration which influences the people that live there. In these places they are being transformed. As we can see Jews are Semitic in nature even though they appear White. The Chinese are multiplying rapidly because they mate with other Chinese. The Whites on the other hand seem to be decreasing in number. The Hyperboreans do not stay long in other regions of the planet because they do not want to change. That is because they belong to an Initiated group of powerful magicians, wise men, great sages, and they are the creators of civilizations. When Atlantis disappeared, a group of missionaries were sent throughout the known world to teach the survivors. First they were taught how to calm the raging waters of the rivers and sea. Then they taught the people how to construct buildings using stone. After the disappearance of Atlantis they constructed buildings that could change the course of tidal waves using secrets of this world. This new science had nothing to do with magnetism or electricity; it only used the currents of the earth. This science resembles using acupuncture on the face of the earth. We no longer have this science today.

Many groups have tried to recover this science. Apparently the Druids recovered it. This science gives us knowledge of the interior workings of our world and this technology turns us into magicians because nobody else understands what the principles behind it are. If we had the knowledge of the ancient city of

Atlantis, if we could have been taught by Hyperboreans or the Druids, we could avoid all natural disasters and probably be able to contact the Hyperboreans in the Antarctic. The science of the megaliths has to do with the vibrations of stone and rock in different centers of the earth. When these rocks become wet from moon water it permits an Initiate to change from one level to another. First he becomes a Druid, then he becomes an Atlantean, and finally he becomes a Hyperborean. It is "Stone music" which changes the nature of things. The Druids inherited the science of the Hyperboreans and Stonehenge was their temple. The construction of Stonehenge created cosmic music and it is magical in nature. Druid means "wise and to see," to see wisely, it means you are a Magician. The Druids are not Celts. The Celts arrived later. The Druids were magicians with the powers of Atlantis and Hyperborea. When the Celts arrived the Druids were already there. They were the guardians of the Holy Grail. Julius Caesar talked of the Druids, he said they were White, very tall, and blonde. They could change the climate at will. They had the power to move and levitate heavy objects and they could cure people. Julius Caesar said that in one battle the Druids did not move just like statues and they were all in deep concentration and the arrows went right through them as if nothing had happened. The Druids however did give great importance to military formations and taught the Celts the tactics of war. This is where the "Knights of the Grail" originated. The Druids themselves did not fight, they did not use weapons, and they did not harm or kill animals or man. They believed in reincarnation. It took twenty years of training to become a Druid and you had to go through four degrees. The number four is the number of the Druid and the number of the Celts. The Druids taught the Celts the Caste system, dividing society up into four Castes: 1. Agriculture 2. Businessman 3. Builder 4. Warrior. The Druid symbol is the Four-Leaf Clover which many today believe is a symbol of good luck and prosperity. The Four-Leaf Clover in reality is a revolving swastika that forms the figure 8, which is a sign of eternity, rebirth, and immortality conquered in the last battle. This is the Grail. Four is not the number of the polar Hyperboreans. Theirs is the number five. Thule was located in the center. The Hyperboreans are the fifth Caste system called

55 Club

Hamsa. It means those without a Caste. The number five is found in the center of the Four-Leaf Clover, in the center of the swastika. The four arms rotate, but the center does not. The number five symbolizes the interior man, the total man, the divine, perfection. It should be mentioned that the dialect used today by the people of northern Italy and southern Switzerland is of the Ancient Celts. In the Hyperborean Initiation the number four is not used. Only the number Five is used. The Cross with a rose is a symbol of the Rosicrucians. The rose transforms into a swastika by spinning around and this is the symbol of the Hyperboreans.

Santiago, Chile

Miguel Serrano

