

Title**ARGUMENT DIAGRAMMING IN LOGIC, LAW AND ARTIFICIAL INTELLIGENCE¹****Authors**

Chris Reed
Department of Applied Computing
University of Dundee
Dundee DD1 4HN
UK
chris@computing.dundee.ac.uk

Douglas Walton
Department of Philosophy
University of Winnipeg
Manitoba R3B 2E9
Canada
d.walton@uwinnipeg.ca

Fabrizio Macagno
Department of Philosophy
Università Cattolica del Sacro Cuore di Milano
Largo A. Gemelli, 1 - 20123 Milano
Italy
fabriziomacagno@hotmail.com

Abstract

In this paper, we present a survey of the development of the technique of argument diagramming covering not only the fields in which it originated - informal logic, argumentation theory, evidence law and legal reasoning – but also more recent work in applying and developing it in computer science and artificial intelligence. Beginning with a simple example of an everyday argument, we present an analysis of it visualised as an argument diagram constructed using a software tool. In the context of a brief history of the development of diagramming, it is then shown how argument diagrams have been used to analyze and work with argumentation in law, philosophy and artificial intelligence.

¹ Douglas Walton and Chris Reed would like to thank the Social Sciences and Humanities Research Council of Canada and The Leverhulme Trust in the UK for a research grant, 'Argumentation Schemes in Natural and Artificial Communication' that supported the work in this paper. Fabrizio Macagno would like to thank the Università Cattolica del Sacro Cuore for a research grant.

ARGUMENT DIAGRAMMING IN LOGIC, LAW AND ARTIFICIAL INTELLIGENCE

Abstract

In this paper, we present a survey of the development of the technique of argument diagramming covering not only the fields in which it originated - informal logic, argumentation theory, evidence law and legal reasoning – but also more recent work in applying and developing it in computer science and artificial intelligence. Beginning with a simple example of an everyday argument, we present an analysis of it visualised as an argument diagram constructed using a software tool. In the context of a brief history of the development of diagramming, it is then shown how argument diagrams have been used to analyze and work with argumentation in law, philosophy and artificial intelligence.

1. Introduction

The technique of argument diagramming is widely used in informal logic. Popular introductory logic textbooks like (Hurley, 2003) now typically devote a chapter to the technique. As used in these texts however, the technique is still not in an advanced state of development. There are disagreements about notation and methodology, and there are some key problems that have still not been solved. These problems have now been addressed in the recent literature on argumentation theory. At the same time argument has come to be widely used in AI (Carbogim *et al.*, 2000; Chesnevar *et al.*, 2000; Pearl, 1984; Pollock, 1995; Reed and Norman, 2003). The latest development of considerable interest in the subject has been the advent of software to aid in the construction of argument diagrams (Reed and Rowe, 2004; Kirschner *et al.*, 2003). These developments have sparked interest in argument diagramming as applied to law, a field where diagramming was used early on (Wigmore, 1931). Advanced systems combining law and AI are found in the work of Schum (1994), who used argument diagrams to model reasoning used in the compilation and evaluation of evidence in a legal case at trial. Law seems to be a natural application for diagramming, although its adaptation to law poses some significant problems. One surprise for informal logic is that the technique of argument diagramming does not appear to have been invented within informal logic and argumentation theory, even though it has often been ascribed to the early textbook of Beardsley (1950). It was highly developed well before that time, and used extensively by the legal evidence theorist John H. Wigmore. Wigmore's technique of using argument diagramming to evaluate legal evidence in cases never became part of the mainstream however, even though it has had its advocates (Anderson and Twining, 1998) and is well known to lawyers because of their familiarity with Wigmore's writings, Wigmore being a giant in the field of evidence law. An even greater surprise revealed below is that diagramming was used, although on a very modest scale, by Richard Whately (1859), who has some claim to being the originator of it, or at least of the idea behind it as a method of argument analysis.

Research using semi-automated diagramming in artificial intelligence and law has recently shown a synergy as it has begun to concentrate on aspects of legal reasoning relating to argumentation and diagramming (Prakken, Reed and Walton, 2003). Argumentation is being used more and more in computer models of reasoning and communication like those in multi-agent systems and natural language processing (Reed and Norman, 2003). And now the most exciting advances in the study of both informal logic and legal argumentation are coming from artificial intelligence. Thus the comparison of argument diagramming in the representation of legal reasoning in evidence law with the use and development of argument diagramming within informal logic is a project of immediate value to AI. This survey will present the exposition in four parts. The first part introduces the reader to diagramming by presenting a simple example of argument from everyday conversational reasoning and shows how the argumentation in it can be analyzed using a new software tool. It also shows briefly

how diagramming has been applied to philosophical argumentation. The second section presents some examples of uses of diagramming in analyzing legal argumentation. The third part presents a brief history of the development of diagramming. Finally, the fourth section explores the approaches to argument diagramming within artificial intelligence, relating it to the philosophical and legal foundations.

2. The Technique of Argument Diagramming

The diagramming technique is used to represent the reasoning structure in a given argument found in a text of discourse. An argument diagram is made up of two basic components (Freeman, 1991). One component is a set of circled numbers arrayed as points. Each number represents a proposition (premise or conclusion) in the argument being diagrammed. The other component is a set of lines or arrows joining the points. Each line (arrow) represents an inference. The whole network of points and lines represents a kind of overview of the reasoning in the given argument, showing the various premises and conclusions in the chain of reasoning. In (Walton, 1996, chapter 6), a reasoning structure is modelled as a directed graph, made up of three components: a set of propositions (points), a finite set of inference steps from one point to another, and a function that maps each step into an ordered pair of points.

2.1 An Example of a Diagramming Using Araucaria

Araucaria is an software tool for argument diagramming based on a representation format, the Argumentation Markup Language, formulated in XML (Reed and Rowe, 2004).² The user begins the process of constructing a diagram by inserting the text of the argument into a text document and then inserting it into Araucaria. The text of discourse will then appear in the left box on the screen. The next step is to identify each statement that is a premise or a conclusion in the argument by highlighting it. As each statement is highlighted and the mouse is clicked while the cursor is on the right-hand box, a letter will appear in that box. The third step is to use the software to draw lines representing each inference from the letters representing premises to those representing conclusions. By this means an argument diagram is constructed of the kind illustrated in the example presented below.

Consider the following example of an argument of a kind one might commonly find everyday conversational discourse.

The Milk Argument

This is a typical everyday argument extracted from an advertisement, shown overleaf. Though there may be reasons for preferring a slightly different solution, one reasonable analysis yields the following Key List:

- (A) *(You should)* Drink Milk
- (B) Including enough milk in your reduced-calorie diet could could provide the nutritional support you need for healthy, effective weight loss
- (D) Emerging research suggests that drinking 3 glasses of milk daily when dieting may promote the loss of body fat while maintaining more muscle

² The Araucaria software can be downloaded from Araucaria.computing.dundee.ac.uk

(E) Calcium is part of the body's natural system for burning fat

(F) Protein is essential for building and keeping muscle

(G) Milk is the only beverage that naturally provides the unique combination of calcium and protein for healthy, effective weight loss support

(H) No other single food item provides more calcium to America's diet than milk

(I) (*There is an*) extensive list of good things that milk can do for your body

Now we need to analyze the argument, to figure out which statements are being used as premises to support other statements used as conclusions. The indicator words like 'and' are clues, but in many instances no such clues are explicitly given, and we have to make judgements, based on our understanding of what is being said. The key part of the argument is the support that B lends to A (this is emphasised by the graphical components and layout of the ad). B is supported by two distinct arguments, one from D, the other from a complex linked argument involving E, F and G. G in its turn is supported by the claim H. Finally, another almost surreptitious argument for the conclusion comes from the claim I, and appears to be completely independent of the weight-loss argument. Note that where several premises are required together (as in E-F-G supporting B), the structure is referred to as "linked", and where multiple premises act independently, the structure is referred to as "convergent".



Drink milk.

Looking to drop a few pounds? Including enough milk in your reduced-calorie diet could provide the nutritional support you need for healthy, effective weight loss. In fact, emerging research suggests that drinking 3 glasses of milk daily when dieting may promote the loss of body fat while maintaining more muscle.

The calcium and protein in milk may help explain these weight loss benefits. Recent studies indicate that calcium is part of the body's natural system for burning fat, while protein is essential for building and keeping muscle. And milk is the only beverage that naturally provides the unique combination of calcium and protein for healthy, effective

Lose weight?

weight loss support. In fact, no other single food item provides more calcium to America's diet than milk. So it's time to add healthy weight loss to the already extensive list of good things that milk can do for your body.

If you're serious about losing weight the healthy way, make sure to exercise, limit your calories and drink at least 3 glasses a day of lowfat or fat-free milk, which have the same amount of calcium, protein and other nutrients as whole milk. For more information on these key studies, and additional important research on dairy and weight loss, visit healthyweightwithmilk.com

got milk?

Zemel MB, et al. Dietary calcium and dairy products accelerate weight and fat loss during energy restriction in obese adults (abstract). *American Journal of Clinical Nutrition* 2002; 75(2S):342S.; Lin Y-C, et al. Dairy calcium is related to changes in body composition during a two-year exercise intervention in young women. *Journal of the American College of Nutrition* 2000; 19:754-760.; Layman D, et al. A reduced ratio of dietary carbohydrate to protein improves body composition and blood lipid profiles during weight loss in adult women. *Journal of Nutrition* 2003; 133:411-417.

©2004 AMERICA'S DAIRY FARMERS' AND MILK PROCESSORS

Many arguments of the kind found in everyday discourse are enthymemes, meaning they have premises or conclusions that were not explicitly stated in the given text of discourse. To get a better analysis, such missing statements often need to be provisionally inserted into the argument (subject to interpretation) as additional assumptions. To analyze the milk argument a bit further the following implicit premises have important roles and could be added.

(C) You want to lose weight.

(J) Providing a great deal of calcium is one of the things required to provide the appropriate combination of calcium and protein

Once these implicit premises have been inserted, following the analysis indicated above, the Araucaria diagram for the milk argument can be seen below. Convergent arguments are represented as two separate arrows going into a conclusion one from each premise. Linked arguments are grouped together by a horizontal line that joins them. Enthymemes are marked by having their implicit premises shown in greyed boxes with dashed edges.

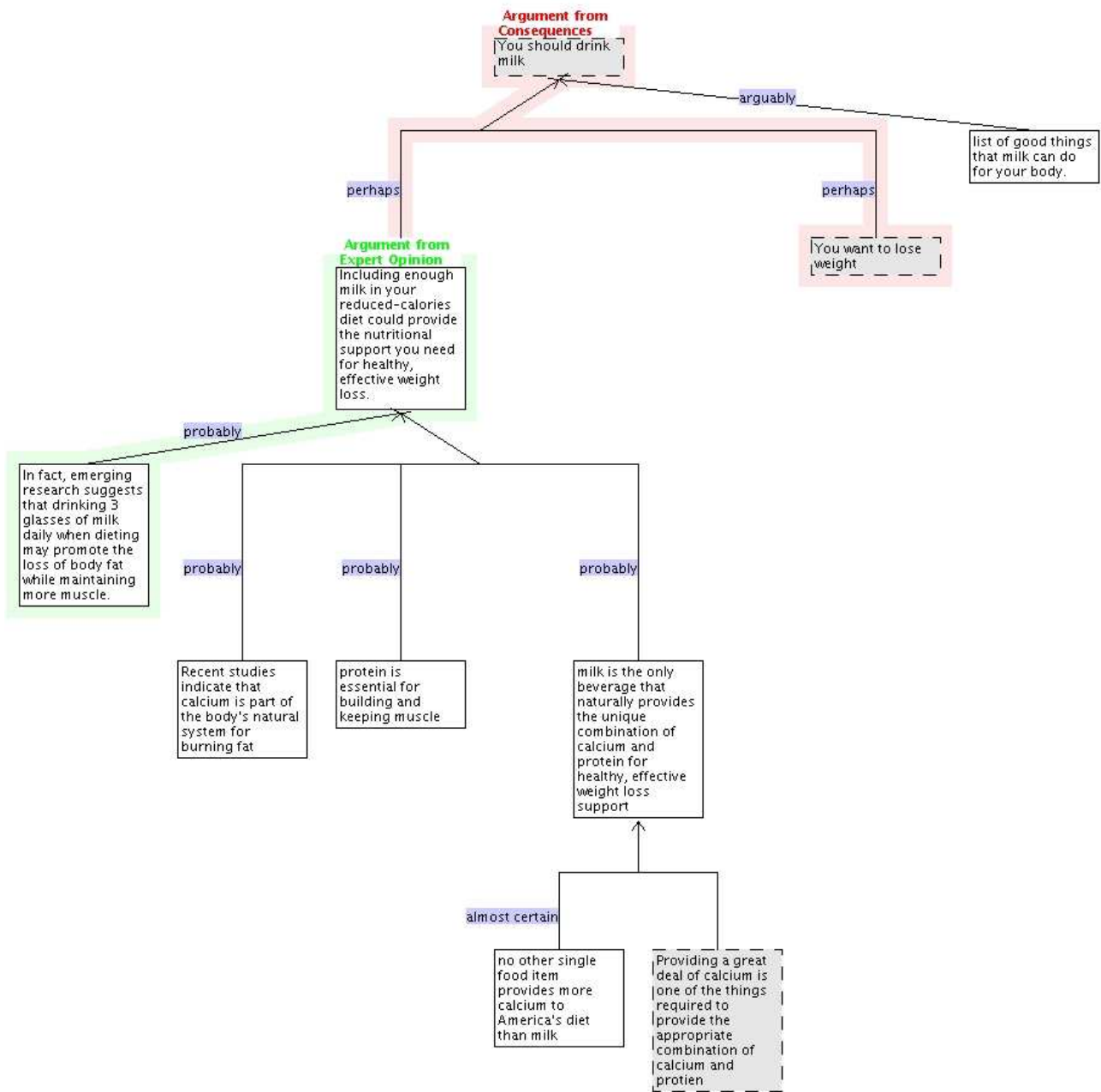

Figure 1. Araucaria diagram for the Milk Argument

There are some other features on the diagram that also require explanation. First, there are shaded areas around the lines. These indicate argumentation schemes representing different types of arguments that function as warrants indicating how the premises are used to justify the conclusion. More about warrants and schemes is explained below. Second, various arrows are marked with words such as “probably”. These represent evaluations of how strong or weak each support is taken to be as a plausible argument. Evaluations can also be placed on individual claims, indicating the strength or

weakness of specific assertions. Such evaluations are unrestricted, and can be qualitative or quantitative (that is, evaluations can be based on arbitrary “data dictionaries” (Krause *et al.*, 1995)).

Finally, the diagram above represents the arguments in favour of conclusion A. If there were arguments against A, you could also represent these of the diagram using a *Refutation*. For example, you could add the following linked argument as a refutation of A.

The Milk Refutation Argument

Milk can contribute to high cholesterol, and eating foods high in cholesterol may not be part of a healthy diet.

The implicit conclusion of this argumentation is that milk may not be part of a healthy diet.

Key List for the Milk Refutation Argument

(L) Milk can contribute to high cholesterol.

(M) Eating foods high in cholesterol may not be part of a healthy diet.

(N) Milk may not be part of healthy diet.

This refutation argument appears on the diagram on the left under N, which is horizontally joined to A by a double arrow.

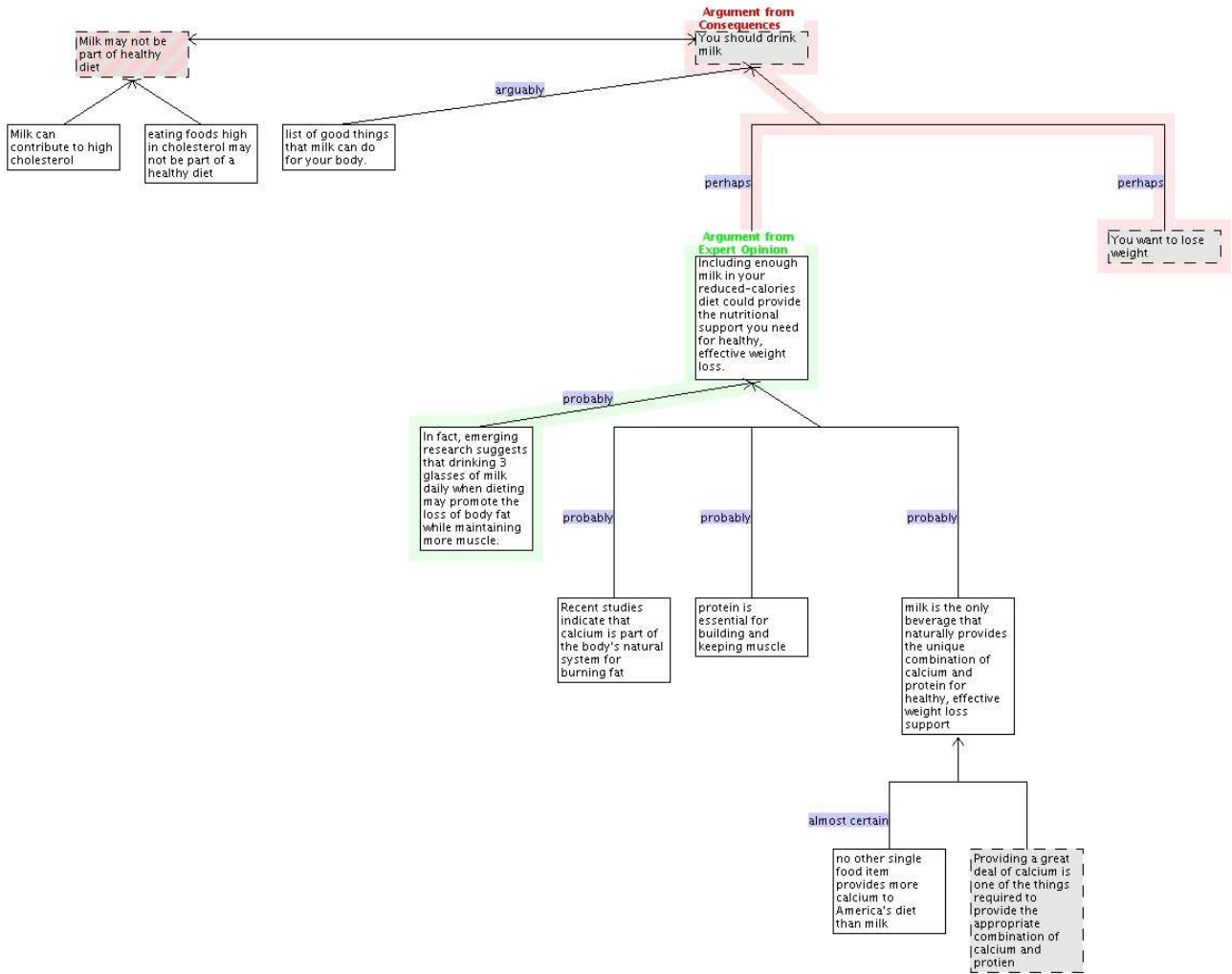

Figure 2. Araucaria diagram including the Milk Refutation Argument

We mention the refutation feature here because it is very important to represent legal argumentation of the kind found in a trial, as will be shown below.

3. Use of Diagramming to Analyze Philosophical Argumentation

The example of the ordinary argument from everyday conversational discourse is fairly simple, even though it represents many problematic aspects, like enthymemes and the distinction between linked and convergent arguments. As the reader can easily imagine, philosophical argumentation tends to be more difficult to analyze. It is often highly abstract and may contain all kinds of difficult terminology. Also, philosophers are typically highly disputatious, and often attack each other's arguments, leading the arguer attacked to insist that her views were unfairly represented. Despite these difficulties, argument diagramming shows promise as an analytical tool for metaphilosophy, and not least for teaching critical thinking and philosophical methods to students.

Here we present one example of the effective use of argument diagramming as a tool for analysis in the history of philosophy and science. In his analysis of Galileo's thought, Maurice Finocchiaro in 1980 introduced diagrams in order to better illustrate the reasoning and sequence of arguments used to reason to determinate conclusions. The following example is from Finocchiaro *Galileo and the Art of Reasoning* 1980, p.377. Even if very schematic, this new approach to the study of philosophy may be an interesting application of the inference and argumentative theories.

(A1) Changes among terrestrial bodies enhance the perfection of the earth; for example, (A2) living organisms are more perfect than dead ones, and (A3) gardens more than deserts. But, (A4) heavenly changes would render heavenly bodies imperfect, since (A5) heavenly changes would be of no use or benefit to man, and hence (A6) they would be superfluous; therefore, (A7) unchangeability would enhance the perfection of heavenly bodies. Therefore, (A8) heavenly bodies are unchangeable. This is also shown by the fact that, since (A6) heavenly changes would be superfluous, and since (A9) nature does nothing in vain, (A10) there cannot be any heavenly changes.

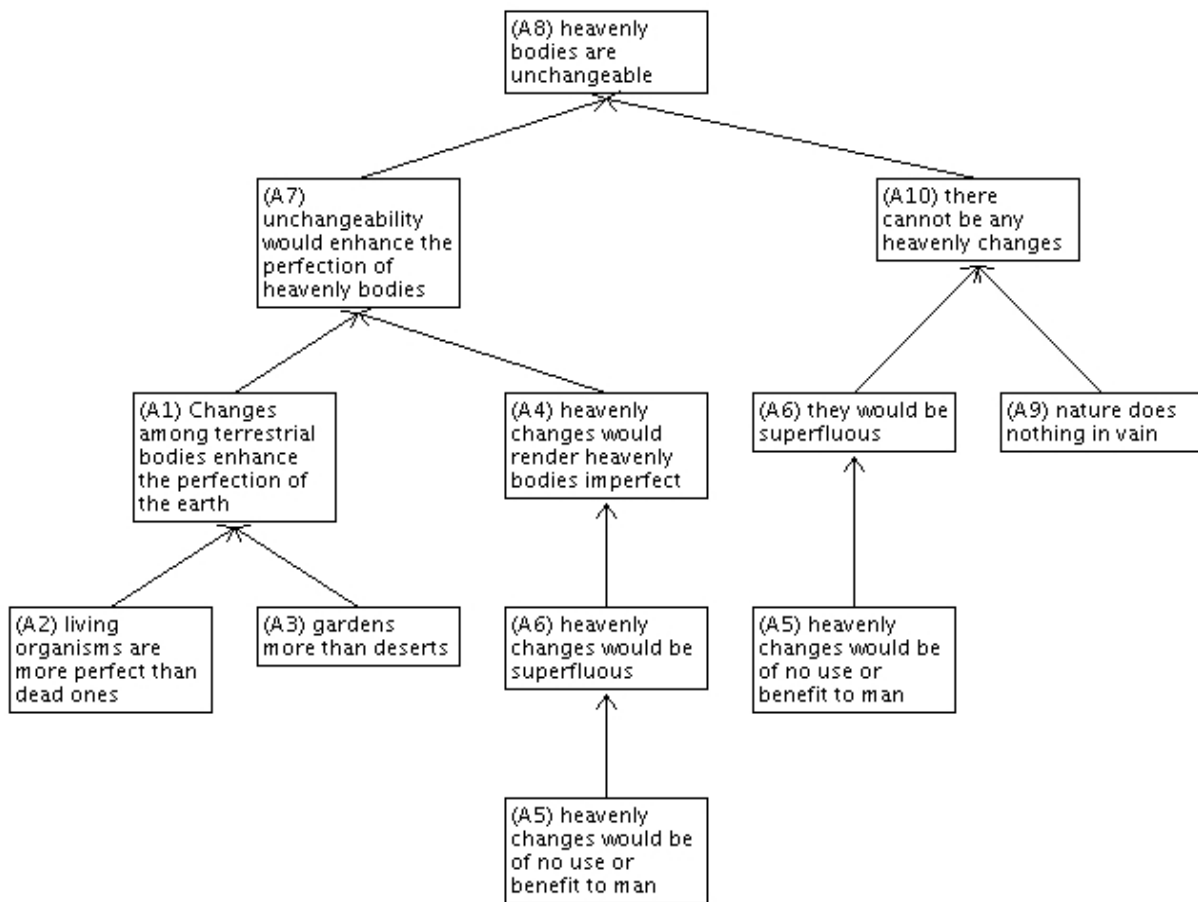

Figure 3. Galileo's reasoning diagrammed

These two sections have demonstrated how argument diagramming works, and how it can be applied both to ordinary arguments, of the kind found in the popular media for example, and to philosophical arguments. Its utility is not a new phenomenon, and diagramming has a long history in theoretical approaches to reasoning and to more or less formal models of logic in particular.

4. The History of Diagramming in Logic

In this section we turn to the use of argument diagramming as it has evolved as a tool for the critical analysis of everyday argumentation through logic textbooks from the nineteenth and through the twentieth century. It began as a practical tool for use in teaching logic. Then in the second half of the twentieth century, it began to be developed theoretically into a more refined method.

4.1. Whately

The first example of diagrams used to illustrate argumentative processes may be traced back to Richard Whately in 1859. Whately, an English logician and Archbishop of Dublin, in Appendix III of

his textbook *Elements of Logic* (1836, pp. 420-430), entitled 'Praxis of Logical Analysis', described a method of argument analysis (pp. 421-423). He described it (p. 421) as a method of taking "any train of argument that may be presented to us", and reducing it to a form in which logical rules can be applied to it.

Basically, the method is to first of all try to figure out what the conclusion of the argument is supposed to be, and then trace the reasoning backward, to try to see what grounds that assertion was made on (p. 421). Then once you have arrived at premises that represent this grounding, you can repeat the process, searching for further grounds for these premises (p. 422). The outcome is what Whately described as the construction of a "chain of arguments" (p. 422), a process he represented by a diagram. The diagram appears in a footnote on the same page. He wrote (p. 422), "Many students probably will find it a very clear and convenient mode of exhibiting the logical analysis of a course of argument, to draw it out in the form of a Tree, or Logical Division; thus", and then he presented the following diagram.

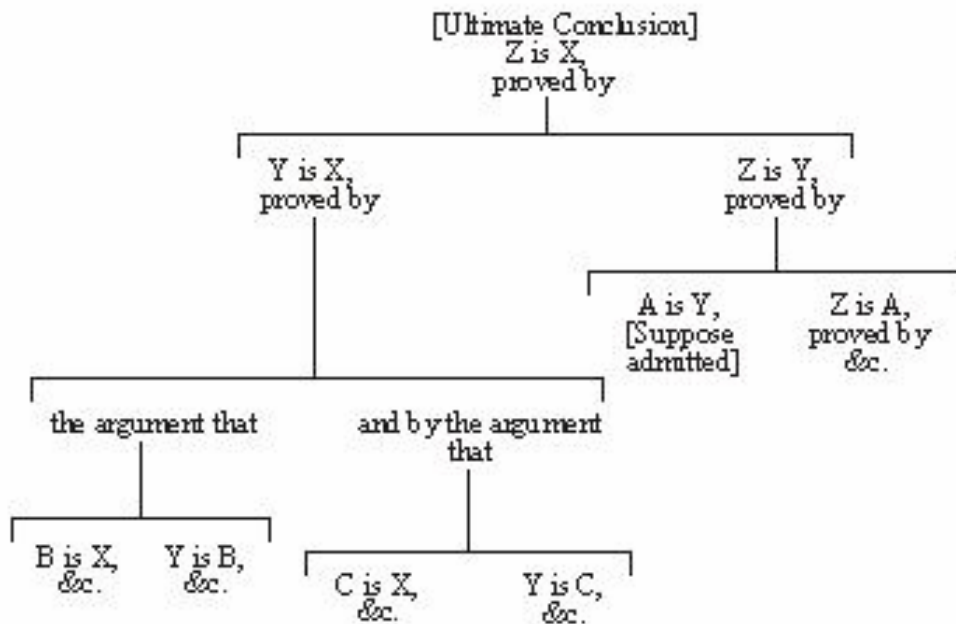

Figure 4. Whately's diagramming (Whately, 1836, p.422)

This diagram has many of the basic characteristics of the modern argument diagram. Statements are represented as the nodes, joined by lines to make up a tree or graph structure. The structure represents a chain of argumentation with an ultimate conclusion at one end. Whately even labelled the statement at the root of the tree "Ultimate Conclusion". Each link or single step in the chain of argumentation takes the form of a conclusion backed up by premises at the next level.

Whately wrote that the Ultimate Conclusion is "proved by" two premises below it, grouped together. Then each premise is "proved by" a separate group of premises that appears below it. It is clear from Whately's representation of the diagram that the structure is expandable. Thus it is shown that the method so represented could be applied to longer and more complex examples of argumentation. Examining Whately's diagram carefully, along with his remarks about what it represents, it is evident that he has given a fairly clear and comprehensive presentation of the method of

argument diagramming that pre-dates Wigmore's chart method. Thus a good case can be made out, from what is known so far in the history of diagramming, for acknowledging Whately as the originator of the method of argument diagramming.

4.2 Beardsley

Whately represented an isolated case in the 19th century. After his first use of it, logic textbooks ignored argument diagramming until the 1950s. The reason is that the theory of argumentation in the first half of the century was taken wholly up by the predominant interest in formal logic. The first example of argument mapping we can find in this period is from Beardsley's *Practical Logic*. In the diagram below of an argument supporting the necessity of freedom in the arts, he divided the argumentative text into statements. He represented the statements as nodes, using circled numbers, and he represented the links between the premises and the conclusion as arrows joining the nodes. He drew what he defined as the "skeletal pattern" of the argument, representing its structure.

Beardsley identified different kinds of links proceeding from reasons to conclusion: they may back track, shift gear in the middle, run in a circle, or go off in several directions (Beardsley, 1950, p. 18). The following example represents a structure of a convergent argument (p. 21).

Though (1) [people who talk about the "social significance" of the arts don't like to admit it] (2) [music and painting are bound to suffer when they are turned into mere vehicles for propaganda.] For (3) [Propaganda has to appeal to the crudest and more vulgar feelings:] (for) (4) [look at the academic monstrosities produced by the official Nazi painters.] What is more important, (5) [art must be an end in itself for the artist,] (because) (6) [the artist can do his best work only in an atmosphere of complete freedom]

Figure 5. Beardsley's example analysis (Beardsley, 1950, p.18)

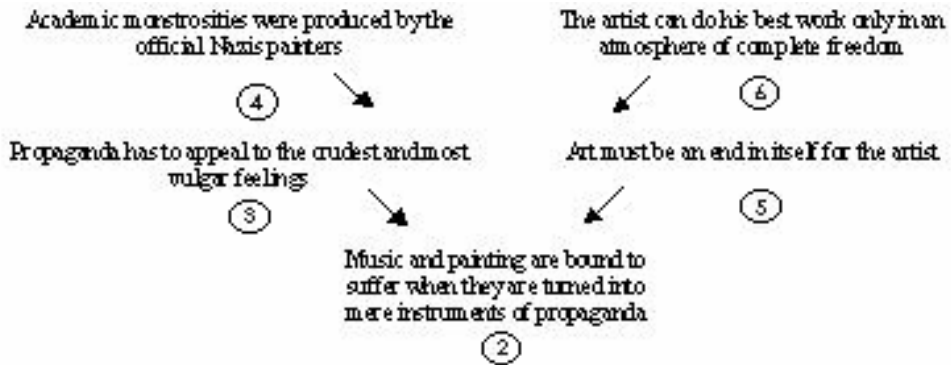

Figure 6. Beardsley's convergent diagrammatic analysis

This is an example of divergent argument (p. 19):

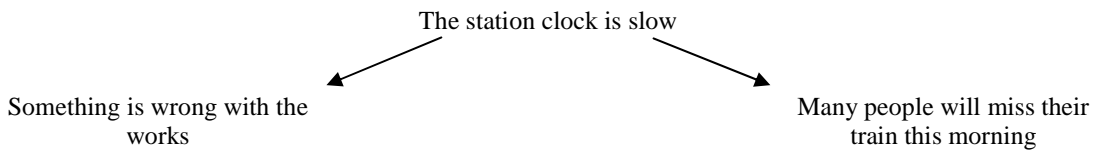

Figure 7. Beardsley's divergent diagrammatic analysis

He defined a serial argument a statement that is both conclusion and reason for a further conclusion (p.19):

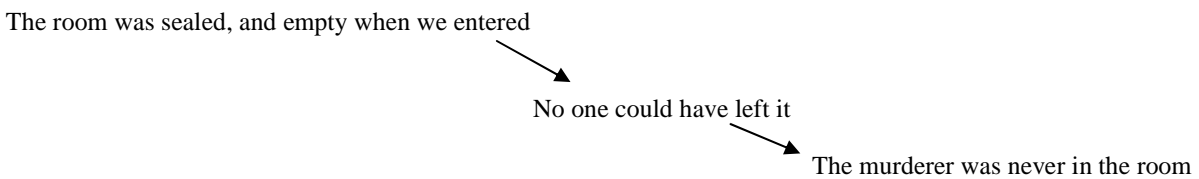

Figure 8. Beardsley's serial diagrammatic analysis

Finally, he gave an example of diagramming the fallacy of arguing in a circle: here is an example on the model of Beardsley (p. 389):

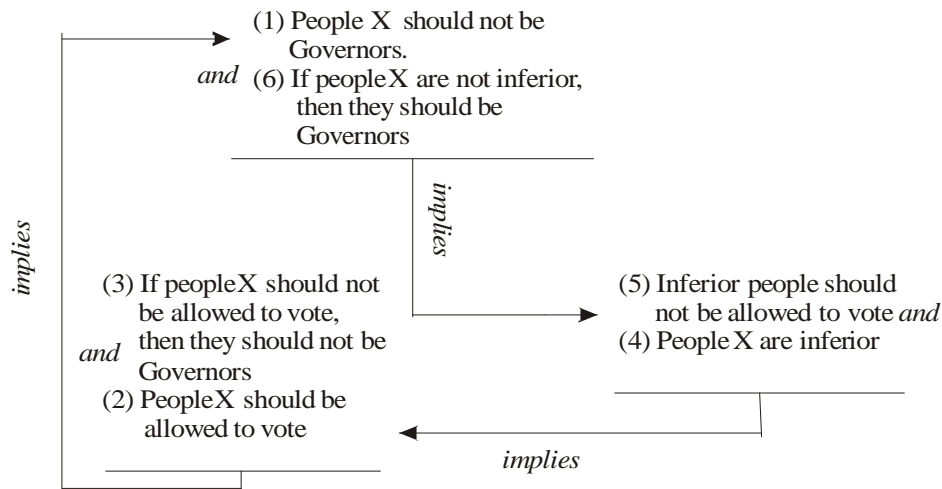

Figure 9. Beardesley's fallacy diagramming

Beardesley diagrams are graphs meant to teach how to organize the reasons for a claim, by examining the different kinds of argument structures representing reasons supporting the claim as a conclusion. He formulated some important general principles of diagramming, such as the Rule of Grouping (if you have several reasons for a certain conclusion, they should be kept as close together as possible), or the Rule of Direction (if you have a serial argument, it should move in one direction, no matter which). Beardesley's use of diagrams, like the one above, was shown by him to be useful to aid in the detection of fallacies like arguing in a circle (*petitio principii*).

We can observe, however, that arrows link reasons and conclusions: no support is given to the implication itself between them. There is no theory, in other words, of inference distinguished from logical deduction, the passage is always deemed not controversial and not subject to support and evaluation.

4.3 Toulmin

The main revolution in the theory of argumentation in the 1950s was carried out by Toulmin's *The Uses of Argument* in 1958. He can be considered the first in the theory of argumentation to take into consideration the defeasible generalization used as the step between the Ground (or Data) and the Conclusion of an argument. To analyze this step, Toulmin introduced the concept of warrant, which he saw as a hypothetical statement that can be subject to defeat in some cases acting as a bridge or link between the two poles. The warrant can be considered as representing the reasons behind the inference, the backing that authorizes the link. He compared warrants with questions of law as opposed to questions of fact. For example, the fact that a man was born in Bermuda leads us to conclude that presumably he is British because there is a law that warrants that inference (Toulmin, 1958, p. 100). Warrants have different natures and support conclusions with different strengths. Furthermore, he introduces the Qualifier representing the degree of force of the inferential link (necessarily, probably, etc.) and showing that the inference is defeasible because the link can fail to hold in some cases. Thus in his scheme other two factors are prominent: the Rebuttal, the exceptional conditions that might defeat the conclusion, and the Backing, the assurances we have or we can provide to support our inferential passage,

The following diagram from Toulmin (1958, p. 111) (constructed using Araucaria) illustrates the general characteristics of his inferential theory:

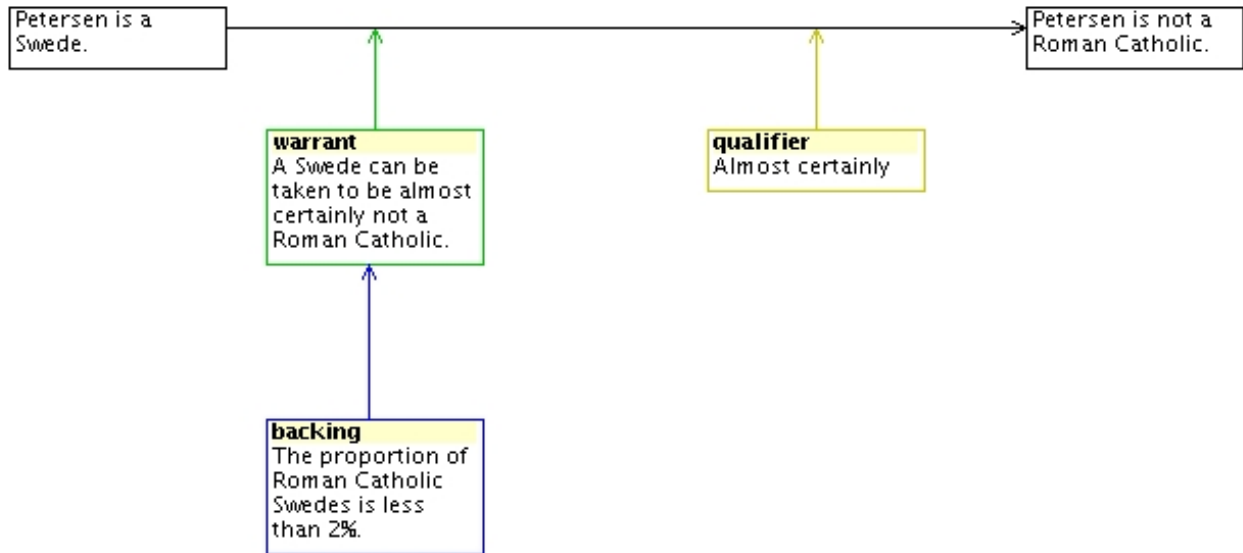
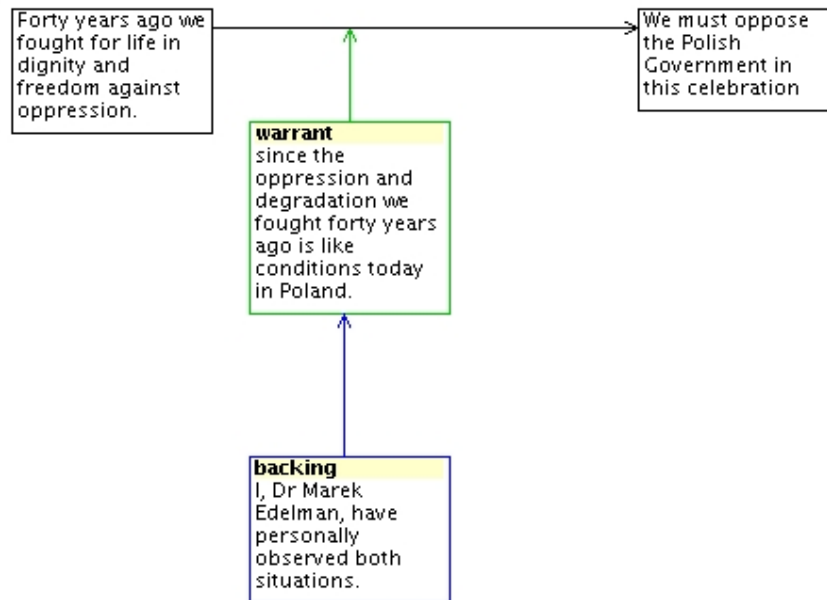

Figure 10. Toulmin's diagram structure

The importance of Toulmin's approach lies in the function of the warrant. It provides the major term of the abbreviated syllogism of the form 'Petersen is Swede; No Swedes are Roman Catholics; So, certainly, Petersen is not a Roman Catholic'. He reduces what we define with enthymematic consequences to syllogisms with tentative conclusions. His interest is focused on the enthymematic relation, and he does not take for granted that the inferential link is necessary, as previous treatments tended to do.

Toulmin connected the notion of inference with the warrant, and with the warrant he reintroduced the concept of enthymeme. In his later work, *An Introduction to Reasoning*, he classified commonly used forms of argument, comparable to the ancient *topoi*. The following example illustrates how he analyzed an enthymeme using what would now be called an argumentation scheme, the one called argument from analogy (Toulmin 1984, p. 218).

Figure 11. Toulmin's analysis of analogical argument



Thus we can see how Toulmin was a man well ahead of his time. During the heyday of positivism, in which only deductive reasoning and inductive reasoning of the Bayesian kind were recognized as forming rational arguments of an objective kind that can command assent, Toulmin boldly set out a paradigm of rational argument that was defeasible, opening the way to the study of argumentation schemes that are not well cast into deductive or inductive form.

4.4 Scriven

In the representation of inferences given by Scriven (1976), one of the most evident characteristics is the evaluation of the role of the premises in supporting the conclusion. He introduces the counterargument in his diagrams, taking into account what Toulmin defined as Rebuttal, and considering it to be a legitimate and important form of argument. Rebuttals are considered arguments leading to a conclusion contrary to the main one. They are what were called refutations, as illustrated above in Araucaria and, as noted there, they are especially important in legal argumentation. The following example shows Scriven's representation of the rebuttal as an independent and contrary line of argument. In the sequence of dialogue, an argument is presented for the conclusion "we should vote for a non-Democrat (a Republican) for President in 1976". Against this position (called NON-D), the statement W "The unfortunate affair of Watergate shows the Republicans (non-Democrats) distinctly inferior to the Democrats in their ability to govern" is advanced, leading to conclusion D "We should vote for a Democrat", opposite to NON-D. The development of this argument in a counterargument is provided by three additional premises, the disjunctive proposition E "Either Democrats or Republicans will win", the negative implicit conclusion of D, NON-B "The Democrats are unlikely to be any better with respect to Watergate-type occurrences", and the final argument V "Voting Republican should not

ruled out...” The whole sequence of counterargument can be represented in a diagram, form showing the argumentative structure of the rebuttal (Freeman, 1991, p. 169, 170).

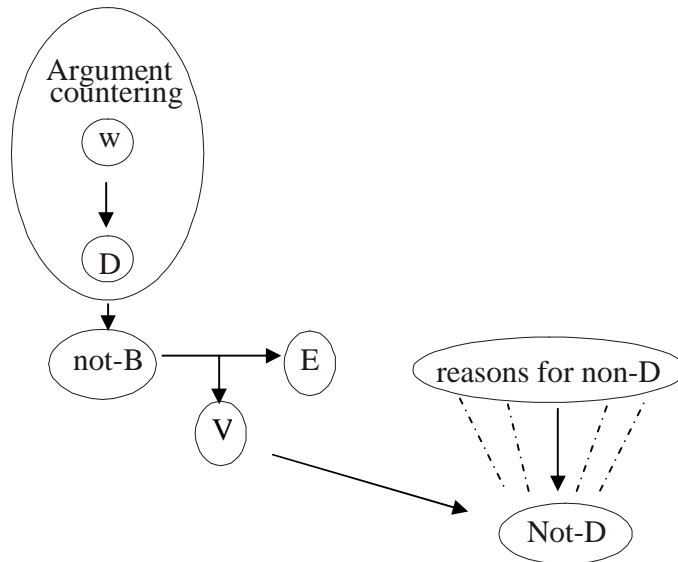

Figure 12. Scriven's diagrammatic account of rebutting

They are divided in premises pro and contra (p. 47).

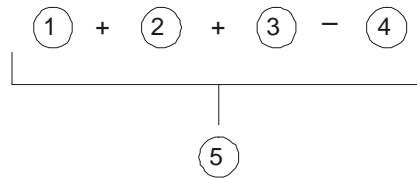

Figure 13. Scriven's premises pro and contra

He also indicated missing premises in his graphs, designed with an alphabetical letter instead of a number (p. 48, 56).

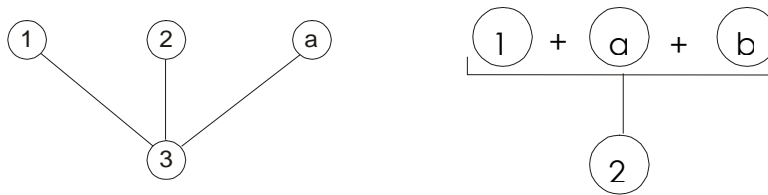

Figure 14. Scriven's account of missing premises

The diagrams become more complex when the conclusion is supported by several premises, which are in their turn backed by other assumptions. They constitute, in such cases, an argument network. In the following example (p. 90), the conclusion, 1, is warranted by elements 8, 9 and 2. The latter is the conclusion of four branches of argument, proceeding from premise 3, 4, 5, 6, 7 respectively. The direction of the inferences is supplied, in his diagrams, with the numerical order of the sequences.

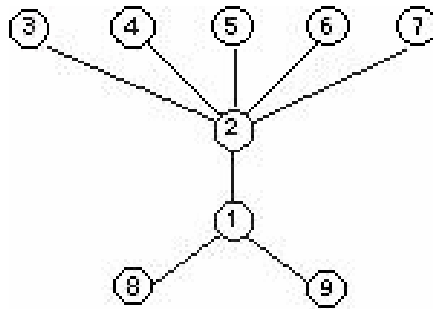

Figure 15. More complex argument diagrams in Scriven's approach

4.5 Freeman

One of the most innovative features Freeman introduced in his diagrams is the indication of supposition. A premise, according to Freeman, can be granted only provisionally, for the sake of the argument. Obviously, the status of conclusions following from them must be taken to be different from the status of the ones proceeding from assertions. Such premises are only provisional assumptions. The arguer accepts them tentatively in order to allow the dialogue to continue, and the conclusion can be considered only hypothetical, depending on the stated assumptions. In the following example (Freeman, 1991, p. 214), the box represents the reasoning based on the suppositions proceeding from 2, leading to the final hypothetical conclusion 1.

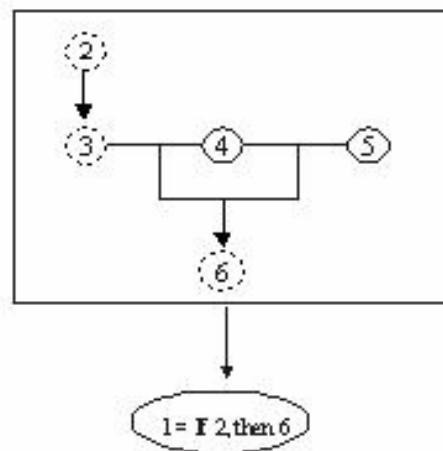

Figure 16. Freeman's approach to diagramming supposition

An important feature appears prominently in Freeman diagrams: the distinction between linked and convergent arguments cited above. He recognized two different structures for arguments, one as constituting independent units supporting the conclusion and the other as arguments linked forming one unit. He defined the first ones as convergent arguments and the second as linked. For example, the syllogistic premises ‘All humans are mortal’ and ‘Socrates is human’, constitute one argumentative unit supporting the conclusion ‘Socrates is mortal’. The model of diagram representing this linked type of argument is shown in the righthand figure below (Freeman, 1991, p. 104).

On the other hand, the conclusion ‘Socrates was a great man’ is supported independently by the premises ‘In his life he pondered the central question of meaning and value’ and ‘In his death he showed an exemplary courage’. The two lines of supporting the conclusion are separate, and thus the argument is classified as convergent. The model of this kind of arguments is graphically displayed in the lefthand figure below (Freeman 1991, p. 105).



Figure 17. Freeman's approach to convergent and linked arguments

The importance of this account lies in its theoretical explanation. The different role of the premises is connected with the application of the notion of relevance to argument evaluation: “if a premise is not relevant to the conclusion, then its being true does not increase the likelihood of the conclusion” (Freeman, 1991, p. 105). In the case of a linked argument, the irrelevance of one or more premises is avoided only if they are connected with the others. For instance, in case of the syllogistic premises in the example above, ‘Socrates is human’ is irrelevant to the claim ‘Socrates is mortal’ because it does not support the conclusion at all, if taken as a independent argument. Only in connection with the premise ‘All humans are mortal’ does it become relevant, increasing the plausibility of the final claim. It is the link, the union of the premises that contributes to the conclusion. Freeman did not attempt to

give a precise account of the calculus of probability or plausibility that can be used to evaluate argumentation based on such links.

But he did show how, in convergent arguments, the standpoints are independently relevant on the basis that each of them adds separate weight to the claim. The probability that they convey is the sum of their own probability. The conclusion is as probable as the sum of their probability. In Figure 18 (Freeman, 1991, p. 127) he introduced the concept of modality of the argument in the diagram, represented by the label M in a square box. It indicates the strength of the conclusion, that is, how strongly the premises support the conclusion. This concept of modality is extremely interesting, because it is not a value subject to a calculus of possibilities. Thus Freeman showed the way to opening up new avenues for approaching the problem of evaluation.

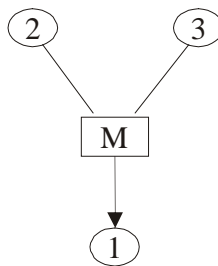

Figure 18. Freeman on modality

It can be also represented as follows:

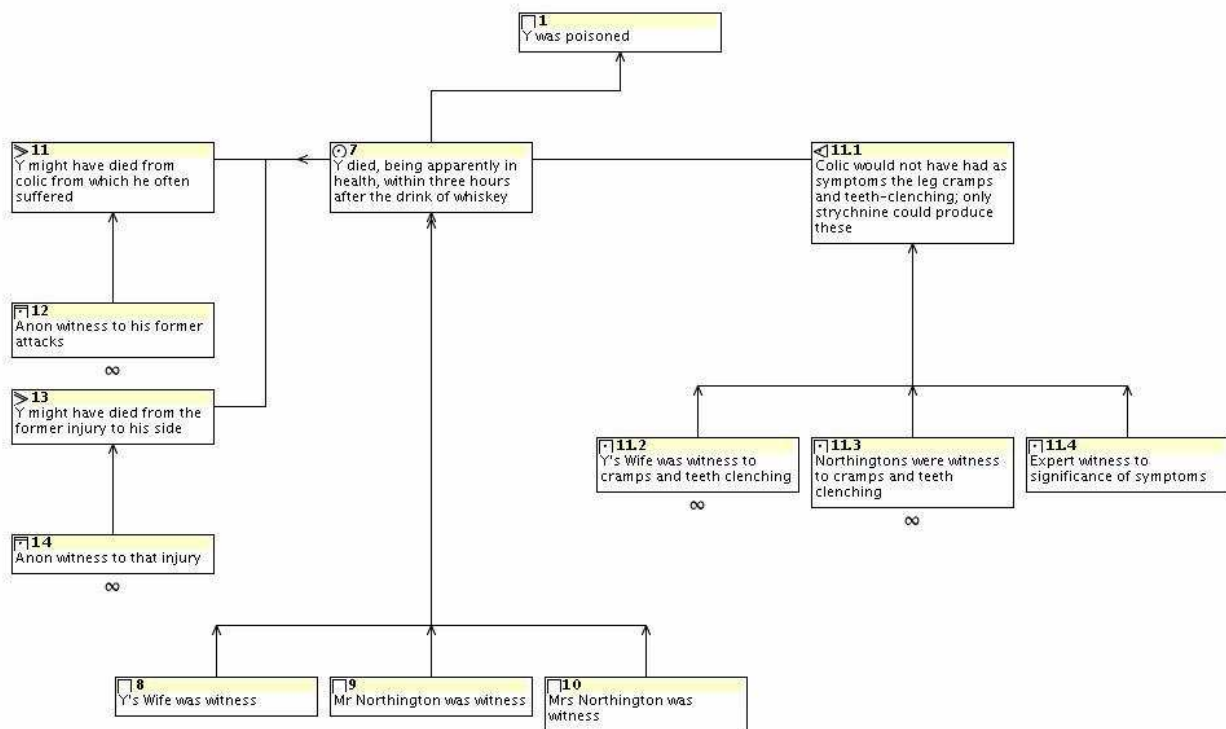

Figure 19. Wigmore diagram example

In this diagram, Wigmore indicated the statement ‘Y died of poison’ as being the ultimate *probandum*, at least of this part of the evidential argument. Circle 7 is an interim *probandum*, and the line connecting 7 with the ultimate *probandum* means “provisional probative force given to the evidence”. The other kind of inference is the type representing strong probative force, connecting, in this example, 8, 9, 10 with 7.

The focus of Wigmore’s interest is proving the validity of the hypothesis given the factual evidence. The direction, consequently, is upward, from evidence to hypothesis (Tillers, 2003, p. 32). The arrow direction indicates the kind of hypothesis evaluation approach Wigmore developed in his theory. It proceeds from the evidence to the hypothesis, the latter being proved or disproved by the evidence. This model may be better understood if compared with Bayes’ diagrams. In these graphs, the arrow direction is downwards, instead of upwards as Wigmore’s ones. Bayes’ diagrams are built on another perspective on the process of hypothesis evaluation, i.e., the confrontation of the evidence with the hypothesis. In other words, the investigation is focused on the problem of evidence materialization of the hypothesis. If the hypothesis is correct, then the assumption is that the evidence must occur in the predicted way. This is an experimental view of hypothesis formation and confirmation (Tillers 2003, p. 32).

Another interesting feature of Wigmore diagrams is the notion of complex inference. The *probandum* is supported by evidence, which is in turn supported by other evidence. The whole process

of proving the hypothesis is constituted by a complex argumentation where facts are warranted by other proofs. Evidence, in other words, is not certain, but must be supported in order to be acceptable as a conclusive proof. This conception, in Wigmore's time, was revolutionary. Only in the 1960s were source uncertainty theories developed, and the importance of linked arguments and complex (or cascade) inferences recognized (Tillers, 2003, p. 37). Wigmore, by utilizing complex inferences, introduced what now is being analyzed by the term "inference networks": nets of links between nodes, influencing each other's probabilities.

From these characteristics there follows the third main feature of Wigmore's charts: the conditional dependency of arguments. Arguments are related each other by dependency links, and their probability is influenced by the probability of the supporting evidence. The force of the ultimate conclusion, for this reason, is the result of a complex calculus of probabilities and factual probabilities. Arrows, in his diagrams, connect nodes (evidence), but not the links themselves. In Wigmore's theory, as we can observe, inferential links themselves are not deemed relevant in the consideration of the relationship evidence-conclusion. They do not need to be warranted: the calculus of probabilities is only based on proofs (nodes), not on the strength of the inference.

Finally, Wigmore, in his diagrams, introduced triangles to indicate a form of evidence distinct from the other kinds of affirmative evidence (squares). These proofs are called "ancillary" - that is, they affect the probability of the evidence. In Wigmore's example, items of ancillary evidence are the ones furnishing proofs for the explanation of the death of Moses Young. Ancillary evidence, therefore, in Wigmore is considered necessary to establish and evaluate a hypothesis about a fact. In modern theories this notion has developed, through the theories of probabilities and inferences, in evidence supporting generalizations (Schum, 1994, p. 191)

5.2 Schum

Wigmore's ideas were developed in a new theory on evidence by Schum (1994). His work is based on Bayesian probabilities and on Toulmin's analysis of inferences. The most important feature, regarding the role of inferences, is the concept of generalization and of ancillary evidence supporting it. The passage from evidence to a conclusion is defined as a "generalization". We can interpret generalizations as proper *topoi*, or forms of warrant that in some cases fall under the main categories of argumentation schemes. Generalizations function in the same way as warrants in argumentation. They allow a conclusion to proceed from premises that function as evidence, and for this reason their function and nature covers the role of the ancient *topoi*. Schum offers examples of maxims like "The events reported by police officers testifying under oath usually have occurred" (Schum, 1994, p. 87). These kinds of principles are useful to understand Schum's original way of building diagrams. His interest is focused on the probability of the link between the nodes, and ancillary evidence acts like Toulmin's backing, i.e., it strengthens or weakens the inferential step.

The following example (Schum, 1994, p. 154) clarifies the function of ancillary evidence. In this case, the inference from E_s to E is weakened by the ancillary evidence A_3 . The function of this kind of evidence is very close to the notion of critical questions in Walton's theory (for example, Walton, 1996, p. 51): they provide critical elements to evaluate the reliability of the proof. The conditions are indicated beside the line connecting the circles (evidence). For example, Mike's observational sensitivity is related to the conditions of evaluation of witness testimony. The black circle represents the directly relevant evidence, while the black squares represent the direct ancillary evidence.

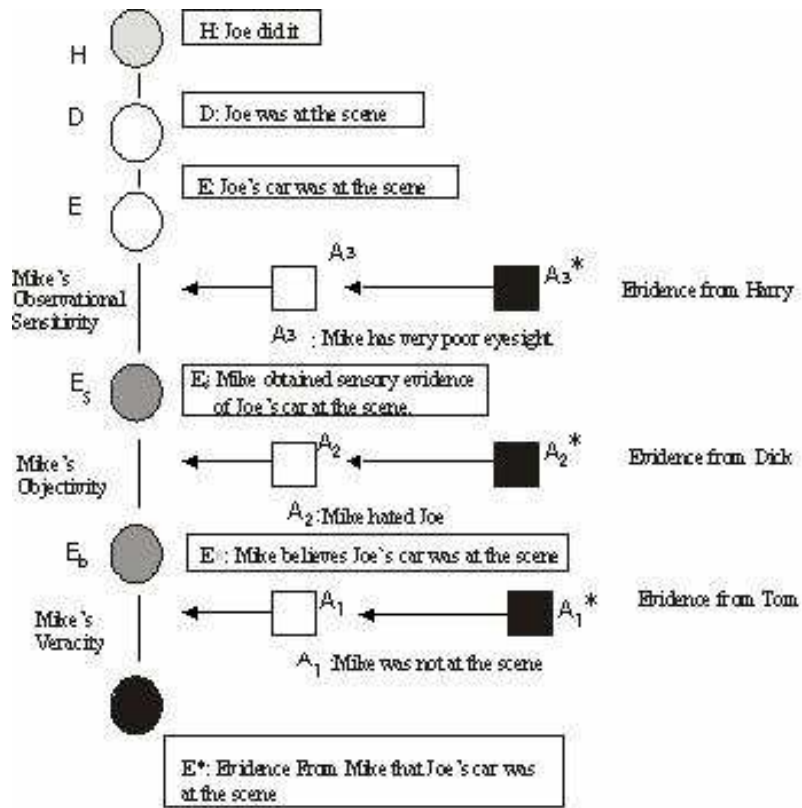

Figure 20. Schum's evidence diagramming

In the following scheme (Schum, 1994, p. 157) showed three of the strategies to support a thesis: by providing support to the inferential link (generalization support), or to the passage from the testimony to the evidence (credibility support), or to strengthen the evidence with supplementary proofs (corroboration).

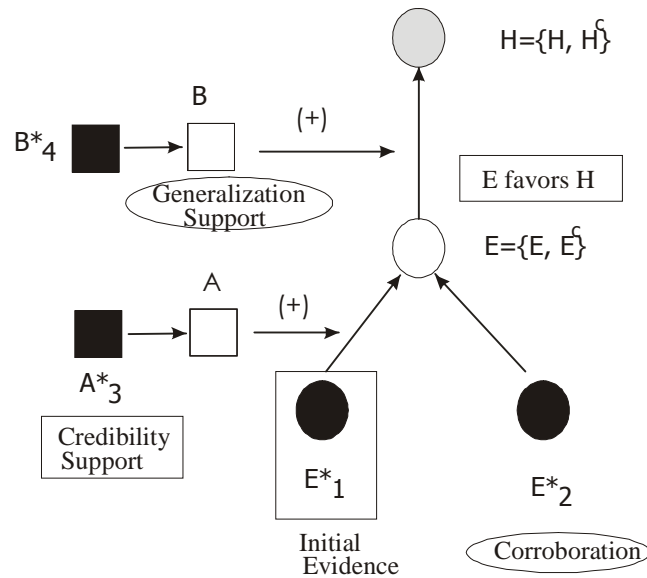

Figure 21. Further features of Schum's approach

From these diagrams, another important feature of Schum's graphs is illustrated: the inference networks. The pieces of evidence may depend on each other. They may, in other words, be connected forming dependencies networks. This notion became extremely important after the introduction of the probabilistic calculus based on the Bayesian approach.

6. Argument Diagrams in Artificial Intelligence

There is a natural relationship between arguments expressed in diagrams and knowledge in AI systems represented using an argumentation theoretic basis. This relationship is bidirectional. On the one hand, existing argumentation theoretical structures in AI are often presented and explored using argument diagrams, with those diagrams acting as an abstraction mechanism. In this way, examples of propositional databases built with Dung-style semantics (Dung, 1995) are presented and investigated for properties such as circularity. For this sort of presentation, internal structures of arguments are relatively unimportant (and are sometimes simply conflated to triangles), whilst the attack relationship between propositions forms a central focus of both the theory and its diagrammatic exposition. Similarly, Bayesian and rhetorical networks used in language generation (Grasso *et al.*, 2000; Carenini and Moore, 2001) are used to summarise the knowledge a system exploits in producing text. On the other hand, diagrams are also used informally to visualise and explore problems of inter-related knowledge, with these diagrams then informing and framing the subsequent development of the theoretical and implemented machinery for handling such information. So for example, the multi-faceted arguments diagrammed idiosyncratically in (Crosswhite *et al.*, 2003) lead to a unique form of implemented context-based argument representation.

There is thus a close tie between diagrammatic and computational representations of argument with the theoretical assumptions of each one framing and constraining development of the other. A good example is offered by comparing (Krause *et al.*, 1996) with (Parsons and Jennings, 1996), both relatively early AI papers making use of argumentation. Despite common roots, in the former, there is a strong formal association with the Toulmin model, and in the latter a similarly strong association with

the Beardsley type model (though this is not made explicit in that work). These different theoretical frameworks inevitably lead to alternative ways of explicating and developing the two models.

Perhaps one of the most influential theoretical frameworks is that of Pollock (2001). Pollock focused his interest on the phenomenon Toulmin defined as Rebuttal (Toulmin, 1958). Using tree diagrams to represent reasoning, a method often used in AI (Pearl, 1984), he analyzed how a conclusion can be defeated, weakened, or refuted by a counterargument. A counterargument can attack the argument at which it is aimed in two ways: it can refute the conclusion itself or it can attack the inferential link between the premises and the conclusion. The first kind of refutation is defined as a *rebutting defeater*. Its meaning is close to Toulmin's Rebuttal. A given proposition S concluded on the basis of a premise R is rebutted when another proposition Q is a reason for denying S . A rebutting defeater attacks the conclusion, whereas an *undercutting defeater* aims to undermine the inferential link between premises and the conclusion. As his leading example, Pollock considers the case of an object x , looking red, illuminated by red lights. The inference is from the perception to the reality of the observed phenomenon: if the object looks red, it is red. The undercutting defeater intervenes by attacking the passage between perception and reality. The fact that the object is illuminated by red lights is not a rebuttal of the conclusion however, because a red object illuminated by a red light looks red. It gives reasons, instead, for doubting that x wouldn't look red unless it were red: that, in other words, the premise guarantees the conclusion (Pollock, 2001, p. 3). He represents the undercutting defeaters as propositions leading to the formula $P \otimes Q$, that is, P does not guarantee for Q . He defines (Pollock, 1995, p. 57) such defeaters as *Reliability Defeaters*, for their action works against the reliability of a reason.

The different kinds of defeaters are shown in the following diagram. In the first figure, the conclusion S is rebutted by proposition Q . In the second diagram, the conclusions following from P and R are opposite and equivalent: in this case they are both rebutted. The third case is an example of how undercutters work. As Pollock explains (2001, p. 7), P = "Jones says Smith is untrustworthy", R = "Smith says Jones is untrustworthy", Q = "Smith is untrustworthy", S = "Jones is untrustworthy". The two arguments conflict with each other on the level of the reliability of the reasons. The argumentative reason to accept Q or S is reciprocally undermined.

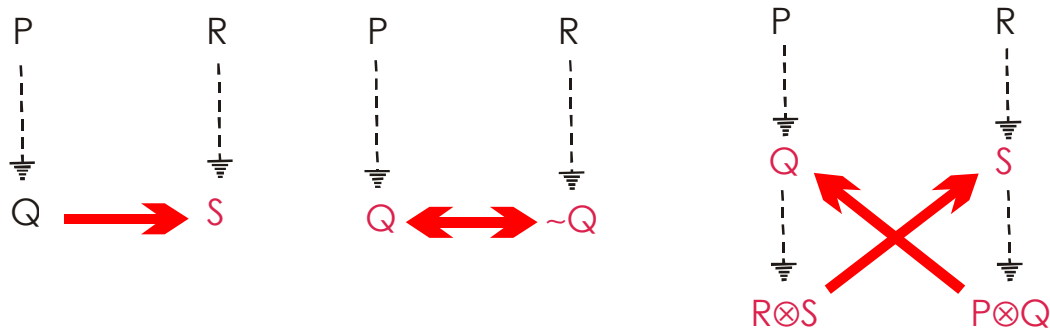

Figure 22. Pollock diagrams

Another important topic raised by Pollock concerns the defeaters and the relationship between strength and rebuttal. A defeater, in order to rebut a conclusion, must be as strong as the argument supporting the original conclusion. In other words, its premises must be as justified (likely to win an argument) as the ones supporting the conclusion. If a defeater is not as strongly justified as its target, it cannot defeat it but only diminish it. In the diagrams, in these cases, the red arrow is not present, while the red character of the contrasting arguments remains to indicate the weakening (Pollock, 2001, p. 25).

Pollock's theory has been influential in many implemented models of AI reasoning (see, e.g., (Chesnevar *et al.*, 2000) for a thorough review), but reasoning is not the only use to which argument diagramming has been put in AI. One key area is “computer supported collaborative argumentation” (CSCA), in which the focus is upon developing tools that help people work together using computer infrastructure. (Kirschner *et al.*, 2003) provide a good overview of the area. Conklin (2003) and Selvin (2003) both explore how QuestMap has been used not only in academic domains, but also for supporting commercial decision making. QuestMap takes a very broad approach, integrating materials often ignored by more traditional diagramming techniques (including background resources such as articles, spreadsheets, pictures and so on), and allowing exploration of a domain in an intuitive and fairly unstructured way.

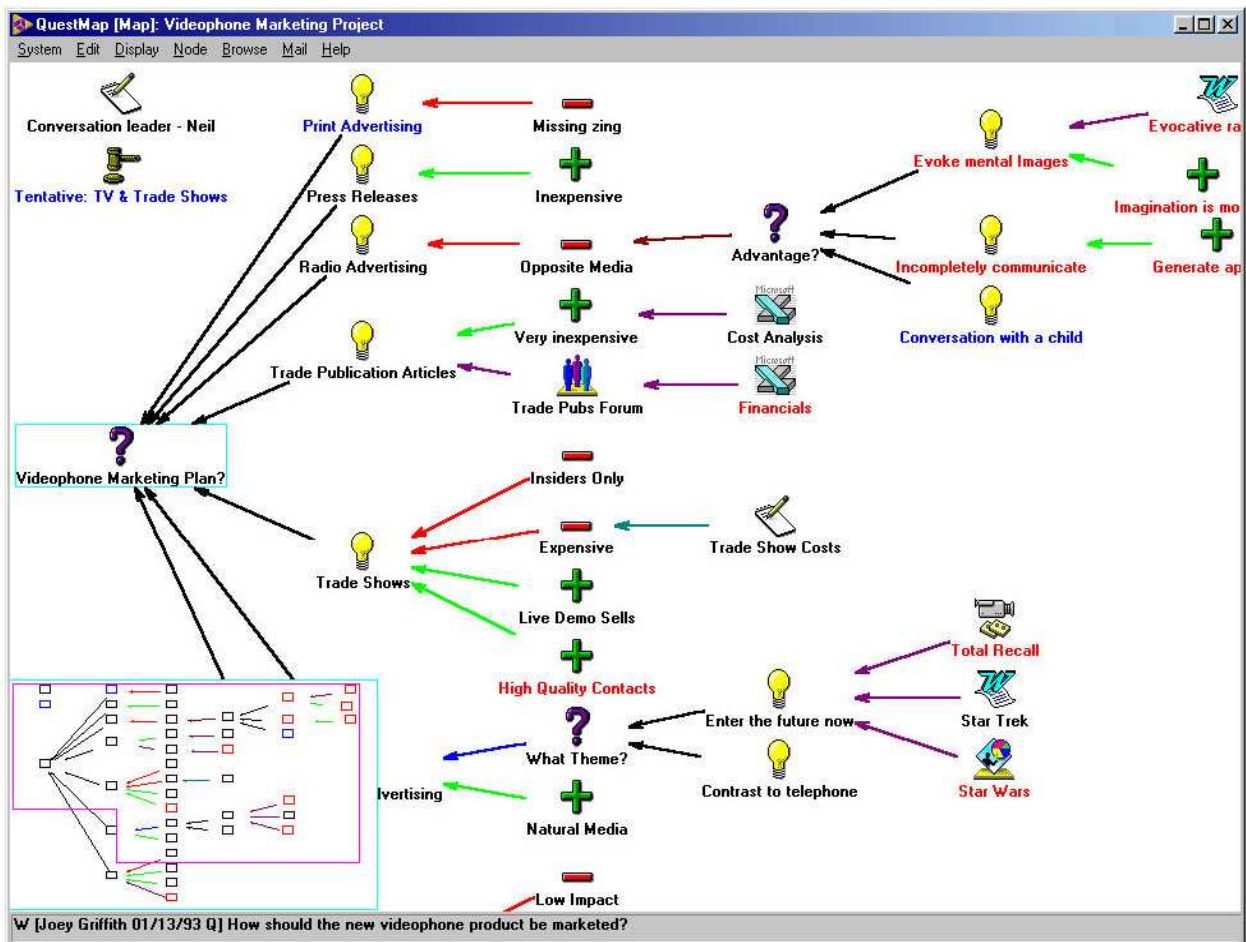

Figure 23. QuestMap

But perhaps the single most successful use of argument diagramming has been with AI tools in education, both in the teaching of critical thinking and argumentation skills themselves, and also as a means to teaching in other subject areas.

In the pedagogy of argumentation, there are a number of important examples of tools developed under the auspices of AI. First is the Araucaria tool introduced in the previous section. It has been deployed in several courses and universities where it has played a practical role in providing opportunities for examples, students' independent study and automated assessment. Further tools such as Athena (Rolf and Magnusson, 2002) follow a similar route, but investigation of the impact of Athena and Araucaria in the classroom is rather immature by comparison to the studies concerning a third tool, Reason!Able (Van Gelder, 2001). Reason!Able is designed specifically for pedagogic use (as opposed to Araucaria and Athena which are both oriented more towards research), and empirical studies have shown that students who are taught argumentation skills using Reason!Able improve significantly faster and further than those taught using other, traditional techniques (Van Gelder and Rizzo, 2001). (A more detailed comparison of Athena, Araucaria, Reason!Able and several other packages in the context of teaching philosophy can be found in (Harrell, 2005)).

Argument diagrams have also been used for some time as a way of abstracting, summarising and presenting complex domains for pedagogical purposes, with Horn's vast argument maps one of the best examples (Horn, 2003):

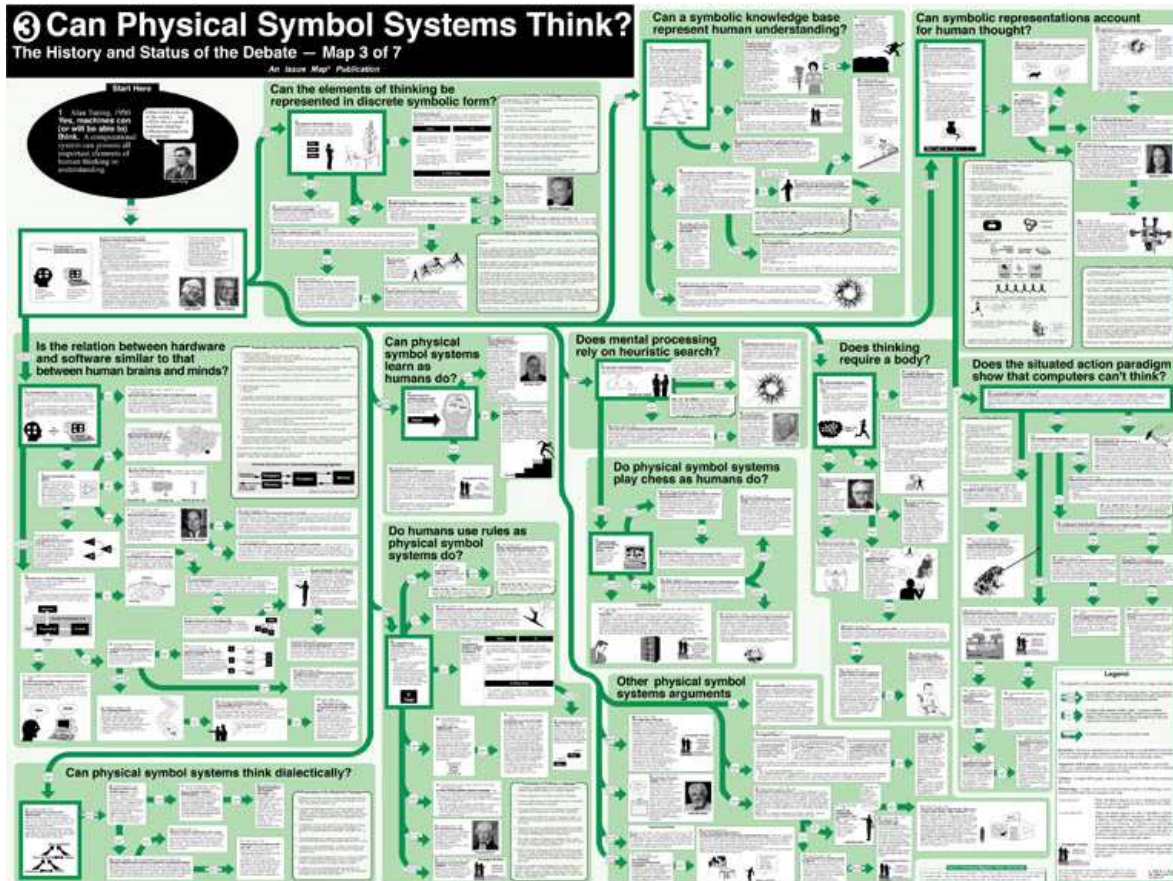

Figure 24. Horn's argument maps

It is perhaps unsurprising, therefore, that AI models of argument diagramming have also been put to work in a variety of educational domains. Belvedere (Paolucci *et al.*, 1995) offers one of the earliest examples, with argument diagrams making concrete the abstract ideas of scientific theories. More recently, the large SCALE project (Hirsch *et al.*, 2004) has investigated both diagrammatic and dialogic argumentation in high school classrooms. Law pedagogy, in particular, has been a fertile area of investigation. Alevén (2003) describes one of the most high-profile systems, CATO, a case-based reasoner that is designed to support law students as they explore cases. It organises on the basis of issues, and supports a variety of argument structures, but targets text rather than diagrams (interestingly, Alevén's presentation makes significant use of diagrams to explain his examples – (2003; Figs. 11 and 15 for example) – even though those diagrams are hand- rather than system-generated). Diagramming plays a much more central role in systems such as ArguMed (Verheij, 2005), where the focus is upon diagramming dialectical argument. For Verheij, a range of diagrammatic conventions are required to uniquely represent each of: support, attack, assumptions, issues, defeat and specificity. This produces complex diagrams such as the following, after (Verheij, 2005: 69):



Figure 25. Verheij's defeasible argument diagrams

One of the key foci of Verheij's work is in capturing Pollock style undercutters and subsequent defeat status in his diagrams (shown in the example above by dashed lines and crossed arrows), which makes the approach particularly useful for those AI models derived from Pollock's theory.

7. Conclusions

Use of argument diagrams to aid in the identification and analysis of argumentation has now been well-established, both as applied to everyday argumentation and in law. Increasingly, these same techniques are being deployed in artificial intelligence for the representation of knowledge and for reasoning. The problem for the future for philosophical, legal and computational development of these techniques is how to evaluate the argumentation once the structure has been identified or represented in a diagram. Though automated techniques of defeasible reasoning of the sort reviewed by Chesnevar *et al.* (2000) are now maturing in AI, what is vital according to the argumentation approach is to look at each argument in a given chain of reasoning, and identify the form of the argument, or so-called argumentation scheme. Then you need to ask the critical questions matching that argumentation scheme. For example suppose the evidence is expert testimony, and the form of the argument is that of appeal to expert opinion. But these are defeasible arguments, as analyzed on the Toulmin model. They tend to be arguments that hold tentatively as acceptable, subject to critical questioning. Matching the argument from appeal to expert opinion, or any other defeasible argumentation scheme, there is a set of appropriate critical questions. Each of these questions needs to be considered, in finding the weakest part of the appeal to expert opinion, the aspect of the argument most open to critical doubt. These techniques should of course not replace those of Bayesian calculations, defeasible reasoning and other nonclassical processing methods, but both practical diagramming and automated reasoning techniques derived from it needs to be extended. Processing argumentation schemes represents a significant opportunity for developing more fine grained theories of argument, for enhancing legal process, and for increasing efficiency of computational systems.

In this paper, a comparison has been made between a technique for modelling reasoning as used in three different fields - informal logic (argumentation theory), AI and evidence law (legal reasoning).

This comparison has produced some revelations that are quite startling for all three fields. One surprise for informal logic is that the technique of argument diagramming was not invented within the recent research in informal logic and argumentation theory. It was highly developed well before that time, by the legal evidence theorist John H. Wigmore. But perhaps another surprise is that it was not invented by Wigmore, and was used by Whately, though not in nearly so well a developed form. It may also be a surprise for legal evidence theorists is that there is quite a widespread use of argument diagramming within informal logic, and quite a literature showing how the technique can be modelled by argumentation systems. Evidence theory, and the study of legal reasoning generally, can benefit from this literature. Although Wigmore did base his theory of evidence on leading writers on logic of his time, argumentation theory was not on the scene yet, and Wigmore's diagram method did not have a theoretical backing and practical sophistication of the kind that has now been provided by the recent growth and advancement of argumentation theory. And finally, though AI is a much younger discipline, it is building models and tools for education, law, philosophy, science, engineering, e-government, and more, drawing on the full gamut of argumentation techniques developed in philosophy and law.

This paper has brought together these previously unrelated bodies of literature on argument diagramming, with the hope of showing how each field how can benefit from the other. In light of the recent lively and productive research in artificial intelligence in law that concentrates on aspects of legal reasoning relating to argumentation, and the increasing use of argumentation in computer models of reasoning and communication, it is high time that such beneficial interaction start to grow.

References

- Aleven, K.D. 'Using Background Knowledge in Case-Based Legal Reasoning: A Computational Model and an Intelligent Learning Environment' *Artificial Intelligence* 150, 2003, pp183-237.
- Anderson, Terence, William L. Twining, *Analysis of Evidence: How to Do Things with Facts Based on Wigmore's 'Science of Judicial Proof'*, Northwestern University Press, Evanston, 1998.
- Beardsley, Monroe C., *Practical Logic*, Prentice-Hall, New York, 1950.
- Carbogim, Daniela, Robertson, David and Lee, John "Argument-based Applications to Knowledge Engineering" *Knowledge Engineering Review* 15 (2) 2000, pp119-149.
- Carenini, Giuseppe and Moore, Johanna "An Empirical Study of the Influence of User Tailoring on Evaluative Argument Effectiveness", *Proceedings of the 17th International Joint Conference on Artificial Intelligence (IJCAI 2001)*, 2001.
- Chesnevar, Carlos, Maguitman, Gabriela and Loui, Ron "Logical Models of Argument" *ACM Computing Surveys* 32 (4) 2000, pp337-383.
- Conklin, Jeff, 'Dialog Mapping: Reflections on an Industrial Strength Case Study' in (Kirschner *et al.*, 2003) pp117-136.
- Crosswhite, Jim, Fox, John, Reed, Chris, Scaltsas, Theodore and Stumpf, Simone "Computational Models of Rhetorical Argument" in Reed, Chris and Norman, Timothy (eds) *Argumentation Machines*, Kluwer, 2003, pp 175-210.

Finocchiaro, Maurice, *Galileo and the Art of Reasoning*, Reidel, Dordrecht, 1980.

Freeman, James B., *Dialectics and the Macrostructure of Arguments*, Berlin, Foris, 1991.

Grasso, Floriana, Cawsey, Alison and Jones, Ray “Dialectical Argumentation to Solve Conflicts in Advice Giving: A Case Study in the Promotion of Healthy Nutrition” *International Journal of Human-Computer Studies*, **53 (6)**, 2000, pp. 1077-1115.

Grennan, Wayne, *Informal Logic*, McGill-Queen’s University Press, Buffalo, 1997.

Harrell, Maralee, 'Using Argument Diagramming Software in the Classroom' *Teaching Philosophy*, 2005, to appear.

Hirsch, L. Saeedi, M., Cornillon, J. and Litosseliti, L. 'A Structured Dialogue Tool for Argumentative Learning', *Journal of Computer Assisted Learning* 20, 2004, pp72-80.

Horn, Robert E. 'Infrastructure for Navigating Interdisciplinary Debates: Critical Decisions for Representing Argumentation', in (Kirschner *et al.*, 2003) pp165-184.

Hurley, Patrick, *A Concise Introduction to Logic*, 8th ed., Wadsworth, Belmont, 2003.

Kirschner, Paul A., Buckingham Shum, Simon J. and Carr, Chad S. (eds) *Visualizing Argumentation*, Springer 2003.

Krause, P., Ambler, S., Elvang-Goransson, M. and Fox, J., 'A Logic of Argumentation for Reasoning under Uncertainty', *Computational Intelligence* 11, 1995, pp113-131.

Palmer, Andrew *Proof and the Preparation of Trials*, Sydney, Australia, Lawbook Co., 2003.

Paolucci, Massimo, Suthers, Dan and Weiner, Arlene, “Belvedere: Stimulating Students' Critical Discussion' in *Proceedings CHI'95*, ACM Press, 1995, pp123-4.

Parsons, Simon and Jennings, Nicholas, “Negotiation through Argumentation: A Preliminary Report” *Proceedings of ICMAS 96*, 1996, pp267-274.

Pearl, Judea *Heuristics: Intelligent Search Strategies for Computer Problem Solving*, Reading, Mass., Addison-Wesley, 1984.

Pollock, John, ‘Defeasible Reasoning with Variable Degrees of Justification II’, greatly revised and expanded version of ‘Defeasible Reasoning with Variable Degrees of Justification’, *Artificial Intelligence* 133 (2002), pp. 233-282. <http://oscarhome.soc-sci.arizona.edu/ftp/PAPERS/Degrees.pdf>

Pollock, John, *Cognitive Carpentry*, MIT Press, Cambridge, 1995.

Reed, Chris and Norman, Timothy J. (eds) *Argumentation Machines*, Kluwer, 2003.

Reed, Chris and Rowe, Glenn, 'Araucaria: Software for Argument Analysis, Diagramming and Representation', *International Journal of AI Tools* 14 (3-4) (2004) 961-980.

Rolf, Bertil and Magnusson, C. 'Developing the art of argumentation: A software approach' *Proceedings of the 5th Conference of the International Society for the Study of Argument (ISSA) Sicsat*, 2002.

Scriven, Michael, *Reasoning*, Edgepress, Point Reyes, 1976.

Selvin, Albert M., 'Fostering Collective Intelligence: Helping Groups Use Visualized Argumentation' in (Kirschner *et al.*, 2003) pp137-163.

Schum, David, *Evidential Foundations of Probabilistic Reasoning*, John Wiley & Sons, Toronto, 1994.

Tillers, Peter, *Picturing Inference, An Essay in Honor of Professor Lothar Philipps*, 2004, <http://tillers.net/pictures/picturing.html>

Tillers, Peter, *Probability and Uncertainty in Law*, International Summer School Lectures, Konstanz, 2003, <http://tillers.net/uncertainlaw/uncertain.html>

Toulmin, Stephen, *The Uses of the Argument*, Cambridge University Press, Cambridge, 1958.

Toulmin, Stephen, Richard Riecke, Allan Janik, *An Introduction to Reasoning*, Macmillan, New York, 1984.

Van Gelder, Tim, "The Reason! Project", *The Skeptic* 21 (2), 2001, pp. 9-12.

Van Gelder, Tim and Rizzo, Alberto, "Reason!Able Across the Curriculum" in *2001: Is IT an Odyssey in Learning? Proceedings of the 2001 Conference of ICT in Education Victoria*, 2001.

Verheij, Bart, *Virtual Arguments: On the Design of Argument Assistants for Lawyers and Other Arguers*, T.M.C.Asser Press, The Hague, 2005.

Woods, John, Douglas Walton, *Argument: the Logic of the Fallacies*, McGraw-Hill, Toronto, 1982.

Walton, Douglas, *Argumentation Schemes for Presumptive Reasoning*, Erlbaum, New York, 1996

Walton, Douglas, Henry Prakken, Chris Reed, "Argumentation Schemes and Generalisations in Reasoning about Evidence", *Proceedings of the 9th International Conference on Artificial Intelligence and Law*, Edinburgh, 2003. New York: ACM Press 2003, pp. 32-41.

Whately, Richard, *Elements of Logic*, Sheldon & Company, New York, 1859.

Wigmore, John Henry, *The Principles of Judicial Proof*, Boston, Little, Brown and Company, 1913, second edition 1931.