

William.A.Smith

HITLER'S

ANTARCTICA

U.F.O.s,

Ahnenerbe

The **BIGGEST** and Most **MYSTERIOUS**
OCCULT Organization in History
with Govt. Funding and Support
from **HITLER**

The Piri Reis map

HAARP

(The **UNTOLD (Alien) REASON** behind
America's **HAARP** project in Antarctica)

Hitler's ANTARCTICA UFOs , the Ahnenerbe Society , the Piri Reis Map , HAARP and other Mysteries

Author : William .A. Smith

Text Copyright © 2015 – William.A.Smith

All Rights Reserved

**No part of this publication may be reproduced or distributed without
the prior permission of the publisher.**

Table Of Contents

INTRODUCTION

1) Operation ' HIGH JUMP ' to ANTARCTIC

2) AHNENERBE SOCIETY of the Third Reich (The BIGGEST and Most MYSTERIOUS OCCULT Organization in History with Govt. Funding and Support)

a) The Piri Reis Map (the Map which stunned Modern Explorers and Scientists)

b) Evacuating the Paranormal Library

c) Paranormal Abilities

3) The FLYING SAUCERS

a) Vril-1/Jager/Haunebu I, II, III, IV

b) Bellonzo

4) THE ANTARCTIC PORTAL

a) U.F.O Sightings

b) Wormholes and Black holes

c) HAARP (The REAL and MYSTERIOUS Reason behind)

5) THANK YOU...!!!

INTRODUCTION

Hitler's life and his belief in super humans or a superior race is well known, but the extends to which he and his Third Reich went to find these in reality is less known and mind boggling. Hitler believed in the 'Hollow Earth' theory where according to legends is inhabited by a human race far superior or much more powerful than normal humans on earth. He intended to seek their help and use their superior technology.

So that on every front from stealth technology to nuclear power Hitler's push for scientific success fueled by the Nazi dream of a Global Reich - a German Empire lasting a thousand years could be a reality. Hitler believed there was an opening to this 'Hollow Earth' in the unexplored Antarctica, thus the Fuhrer (Hitler) had sent expeditions to the South pole (aka Antarctica) for the very same purpose. Also he had other intentions like to exploit the vast natural resources of this unexplored continent (the sixth continent bigger than Europe, is rich in Uranium which could really help him fuel-up his super-planes) and also set-up a safe base there.

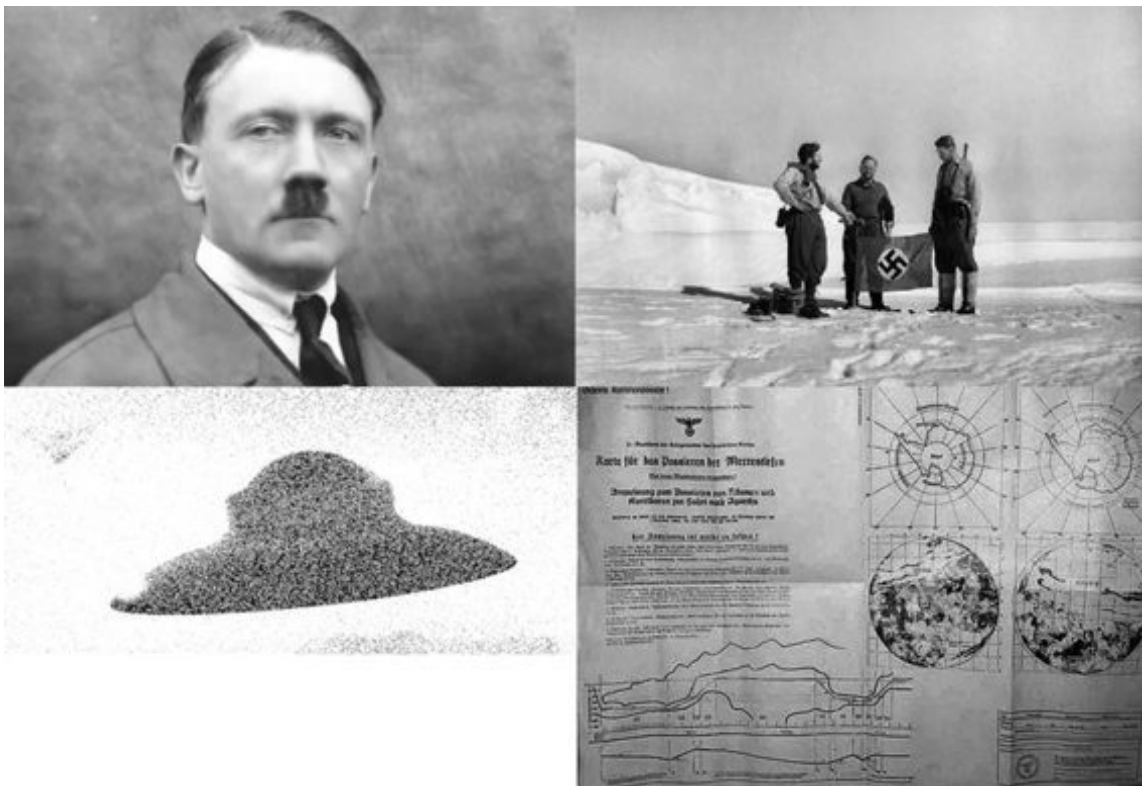

The Ahnenerbe was an occult society formed by Hitler's highest ranking officials whose secret intensions was to explore the reality in religions and myths around the world. The idea was to combine the ancient super knowledge to current scientific knowledge and to make the Third Reich 'the Untouchables'. Even now, the secret services of leading powers hunt for Ahnenerbe's secrets. It is of no doubt that they attained great unknown knowledge and sadly also destroyed some of it (mainly books, they literally burned them on a mass scale) before it could be disclosed to the world. But many records of their quest for ancient knowledge are still hidden out there to be found and benefited from.

According to Ahnenerbe, there were people and civilizations much before the current records of the beginning of humans, who attained much more knowledge and advancements in every fields than the so called 'Modern men' today. But somehow these civilizations got wiped out completely due to some natural calamity, and thus we humans had to start again from scratch.

Hitler's Ahnenerbe also believed humans were not alone in this gigantic universe consisting of millions of planets and solar systems (stars). They believed a higher knowledge were locked and hidden away in various parts of the world in the form of ancient manuscripts, carvings, books, etc. And the people who could lay their hands and join the pieces of this 'forgotten ancient puzzle' (scattered all around the world) could be the new super powers and could rule the world.

Americans have always been interested in the 'techno-magical' legacy of Germany. Consequently when they defeated Germany in World War 2, they were eager to attain all the German secret knowledge.

But the Allies were shocked to discover that thousands of highly qualified Third Reich specialists had vanished and weren't listed as dead. Over a 100 German submarines had also vanished, never to be found. The rumor was that these scientists were shifted to Antarctica along with their huge labs and machinery in these missing submarines. Thus America had to make sure that they had completely won over Germany and will not be sadly surprised by an attack with German Super-Weapons, which they may not be able to even respond to. So the US military plans a secret expedition to Antarctica code named 'Operation High jump'.

Suddenly the inexplicable occurs; the expedition, designed to last 6 months, is quickly aborted after two months, leaving the Antarctic coast deserted. It was an actual retreat.

(Note: We present

- Real Facts,
- Reliable Evidence and
- Sensational phenomenon in the book.)

1) Operation ‘ HIGH JUMP ’ to ANTARCTIC

At the beginning of 1947, yet another expedition by the American explorer, Richard Byrd, arrived on Antarctic shores. It was a very strange expedition. Unlike his previous three expeditions, this one was completely financed by the U.S. Navy. The expedition was named ‘ Operation High Jump ’. Under the command of Admiral .R. Byrd there was a powerful military squadron.

- An Aircraft Carrier
- 12 Surface Ships
- 1 Submarine
- More than 20 airplanes and helicopters
- And about 5000 people on staff.

Yes....you will agree a very strange team for just a scientific expedition.



December 2nd 1946, before the start of his expedition Admiral Byrd, at a press conference said: “ My expedition is military in nature”. Giving no further details.

At the end of January 1947, full scale aerial reconnaissance began surveying the Antarctic Region of Queen Maud Land. It all went to plan in the first weeks, tens of thousands of photos were taken. Suddenly, the inexplicable happened. The six month expedition was suddenly terminated after just two months, fleeing the Antarctica coast, it was a real fast retreat. They lost a destroyer, almost half their carrier based aircraft, dozens of sailors and officers. To commission investigation members of the U.S. Congress, Admiral Byrd, said the following: "In the event of another war, America can be attacked by an enemy that has the ability to fly from pole to pole with incredible speed.”

What made the Americans flee? In 1945, 18 months before Admiral Byrd's expedition began, two German submarines entered Mar del Plata port in Argentina surrendering to authorities. These were no ordinary submarines, they were from the so called 'Fuhrer Convoy'. This was a top secret fleet, fulfilling missions: details have remained a secret till now. The submarine crews were reluctant to cooperate, even so the Americans learned a few things. The commander of U-boat U-530, spoke of his involvement in an operation code named – ‘ Valkyrie II ’. Two weeks before the war's end, the U-boat U-530 left the quay, heading for the shores of Antarctica. On board of the submarine, were passengers with faces covered in bandages, as well as Third Reich relics. The commander of another U-boat, U-977, Heinz Schaeffer, later testified that he followed the same route. It was found that the German submarines repeatedly followed the Antarctic route. But why go there..??.... ‘ANTARCTICA’.

In 1820, Antarctica was discovered by two Russian explorers: ‘ Gelenkschmerzen ’ and ‘ Lazarev ’ – (in Image below)



Since then this mysterious continent, bigger than Europe, continues to attract explorers like a magnet. However the 10 meter high, sheer icy shores, made the continent impregnable for many years. For almost a century Antarctica remained unknown. Only coastlines were marked on the map. Suddenly, this distant and useless icy continent, aroused a strange interest in the Germans. Large funds were allocated for Antarctica study. In the late thirties, two research expeditions were arranged. This happened just before the war was due to start.

In January 1939, two catapult controlled Airplanes – the ' Passat ' and ' Boreas ', took off from the deck of the ' Schwabenland '. They began patrolling Queen Maud Land. In three weeks, Luftwaffe pilots with metal pennons marked with swastikas managed to secure for the Third Reich - territory the size of Germany. 'New Swabia'.

In April 1939, the experienced polar explorer, Captain Alfred Ritscher, wrote (in Image below) :



“ I have completed the mission entrusted to me by Air Marshall Goering. For the first time German aircraft flew over the Antarctic continent. Every 25 kilometers we dropped pendants covering an area of about 600,000 square kilometers. Of which 3,50,000 square kilometers were photographed. Goering’s flying aces had done their job. This unusual mission then passed to the Fuhrer's Sea Wolves: the U-boats commanded by Admiral Karl Doenitz. In secrecy the U-boats set course to the Earth’s end - the icy Antarctic shores.

Later, Karl Doenitz let slip a strange phrase: " My submariners have found a true paradise on Earth."

In 1943, at the peak of the war with Russia, Grand Admiral Doenitz, uttered another, no less mysterious phrase:

“ The German submarine fleet is proud. At the other end of the world we have made an impregnable citadel for our Fuhrer.”

Back then, the Grand Admiral of the German naval fleet's words were only understood by a very small circle of insiders. Today we can only hypothesis what the Grand Admiral meant. Recently, huge underground lakes were found a kilometer deep under the ice. The lake’s temperature is 18 degree Celsius. Located above the water’s surface are dome like vaults filled with warm air. It’s possible that from these heated lakes, a constant river of warm water flows into the ocean. These warm rivers may have formed large underground ice tunnels, perfect for the construction of secret bases. From the ocean’s edge, any submarine could easily pass under the coastal ice into the tunnels, immune from storms and polar cold. Totally hidden from outsiders and out of the enemies reach.

If the Germans had to decide on a location for a secret base, or make a secret zone, that seemed from the outside to be totally inaccessible- the polar zones including Antarctica would be a wholly suitable area to find this level of security.

According to witness testimony and other documents, the Nazis, had in fact managed to create a top secret Antarctic base. It’s codename was ‘ The Base 211 ’.

At the start of 1939, regular trips were made between Antarctica and Germany, in a specially equipped and modified research vessel named the 'Swabia'. Mine constructing equipment and other machinery, including rail roads, trucks and giant tunnel building mills, were transported to Queen Maud Land. At the same time, scientists, engineers, and highly skilled workers arrived. Why was Germany in need of such a remote base..??. There are various assumptions –

- Some believed that Germany wanted control of the Southern seas.
- Others thought, Germans were attracted to vast Antarctic natural resources such as Uranium, which is essential for the creation of super weapons.
- Many assumed that in case of defeat, Antarctica would be a safe haven for the elite of the Third Reich.

By 1942, transfer of inhabitants to New Swabia had begun: including scientists, engineers, members and representatives of the Nazi Party and German State. Certain secret industrial technologies were also transferred from Germany.

Post war, the Americans recruited German scientists to work in the United States, but were shocked to find thousands of highly qualified Third Reich specialists had vanished and weren't listed as dead. Over a 100 submarines had also vanished, never to be found.

It's clear that American intelligence obtained information, concerning the fact that part of the Nazi legacy, its technical potential, in terms of researchers and scientists, had evacuated from Germany and naturally the Antarctic polar zone became the center of their attention. There's also the testimony from German submariners who surrendered to Argentine authorities, it seems all this extremely alarmed the Americans.

At the end of 1946, the famous polar explorer and Admiral of the U.S. Navy, Richard Byrd, received the order to destroy the Nazi base in Antarctica. But things went wrong. The resistance met by the American squadron, even now raises many questions. Admiral Byrd not only reported seeing fighter jets with incredible capacities, he also discussed an attack on

the expedition by strange ' Flying Saucers '. They emerged from the water at high speed, causing heavy damage to the expedition.

On February 26th 1947, a battle took place which is described by the member of the expedition, - an experienced pilot called John Sireson.

" They flew vertically out of the water in a fury, slipping between the masts of the ships with such speed, that the air flow perturbed and dislodged the radio antenna. I didn't have time to blink an eye, the two Corsair from the Casablanca were slain by some kind of mysterious ray, shot from the nose section of the flying saucers. They then dived into the water near the ships. At the time i was on the Casablanca's deck, and saw it as you now see me. I didn't understand, - these objects were silent as they floated between ships, like a satanic beast spitting deadly fire. Suddenly I saw our destroyer ship ' Murdoch ' , which was about 120 feet away; the flames flashed and it began to sink. Despite the danger, rescue teams and lifeboats were immediately dispatched to the disaster site from other ships; the nightmare lasted about 20 minutes. When the saucers again dived under the water, we evaluated our losses. They were terrifying....!!!!."

Who did these flying saucers belong to? Could it have been Nazi Germany..??

After World War 2, in Nazi secret archives intriguing photos and drawings were discovered . They proved that German scientists were actually engaged in the development of disc-shaped aircrafts. At the time nothing like this existed.

Questions still remain - How had Nazis scientists managed to make such a technological leap..?

(Below a rare collection of images of real Nazi U.F.O sightings)

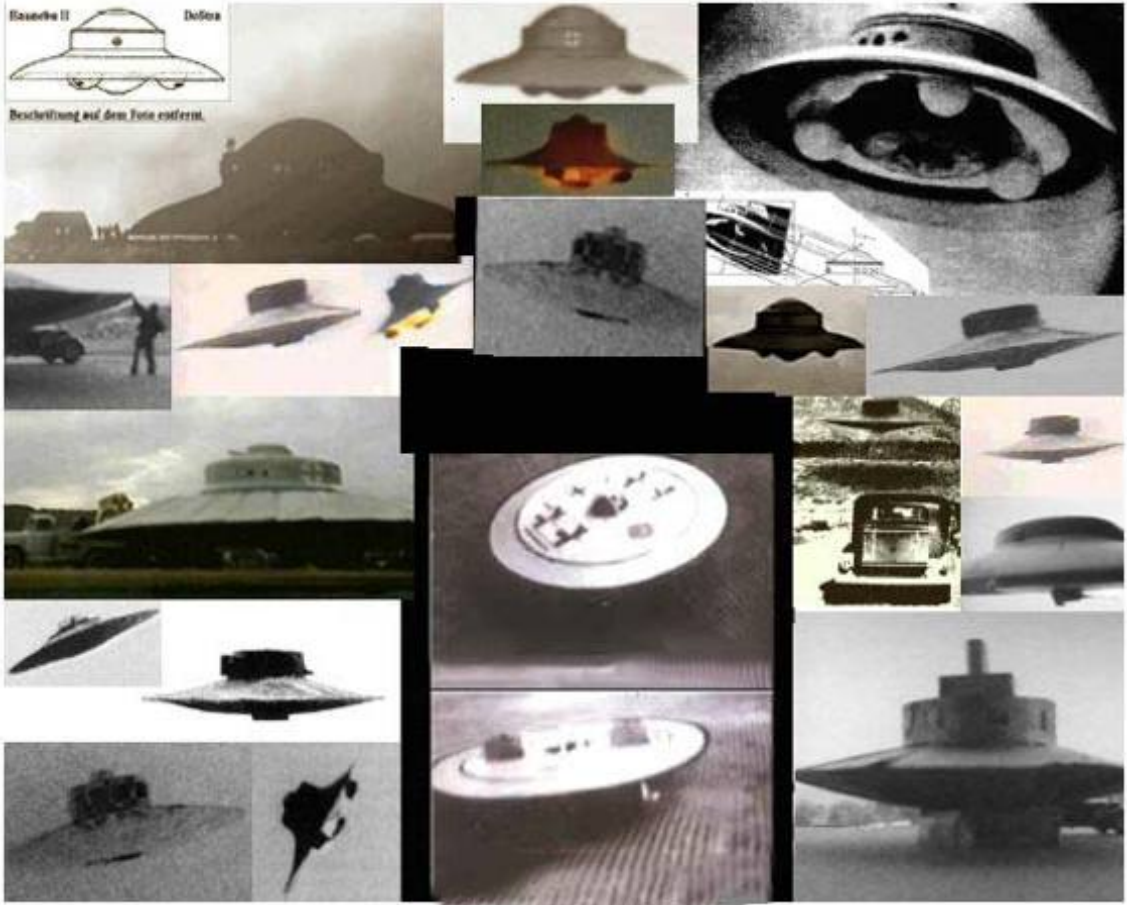

2) AHNENERBE SOCIETY of the Third Reich (The BIGGEST and Most MYSTERIOUS OCCULT Organization in History with Govt. Funding and Support)

Ahnenerbe Society:

Even now, the secret services of leading powers hunt for Ahnenerbe's secrets, but why..?? The answer is simple, this was the only known historical structure engaged in the study of the occult and mysticism, to have state funding and support. No organization in the world had at its disposal, such a volume of data, or had such influence on the development of occult technology, as the Ahnenerbe. The Ahnenerbe founders were drawn from the highest ranks of the Third Reich. Research on occult knowledge and paranormal phenomena by the Ahnenerbe received blessings from SS Reichsfurher Himmler. Who not only acted on his own initiative, but also with instructions from Adolf Hitler.



Officially, the society was founded in 1935, and was intended to explore the historical roots of the German Nation. Ahnenerbe, when translated, means ‘ legacy of the ancestors ’. However, the society's scope of interest was broader than ancient German history study. Third Reich leaders, understood an army's size wasn't necessary to win future wars. Therefore, they adopted the so-called concept of " Qualitative Superiority ". Therefore, one can win a war with relatively low quantitative forces, while utilizing high qualitative forces. To provide them with qualitative superiority, the Ahnenerbe brought in specialists in the occult, non-traditional and paranormal knowledge. In order to achieve a breakthrough in an area where their opponents would not be competent. Nazi ideology was based on the theory that in the past, there was a powerful Earth civilization with access to

the Secrets of the Universe. Somewhere encrypted and scattered this higher knowledge was preserved.

Specifically they were tasked with reviving the 'super human' in Germany, in their role as ancient Aryan descendants. They were very interested in Atlantis, their scientists believed it- the Aryan race's native home. Therefore, Germany was the rightful heir to Atlantean technological knowledge. Legend says, it's where giant ships and flying vehicles, were driven by an unknown force. To search for hidden knowledge, to seek knowledge of the history of civilization. The cradle of civilization they assumed was of German origin and all world civilizations had German roots.

a) The Piri Reis Map (the Map which stunned Modern Explorers and Scientists)

The Ahnenerbe's search began just prior to World War 2's start. There's no doubt that Ahnenerbe members knew of an amazing map that was discovered by historians in 1929. The map was created in the early 16th century by the famous Turkish Admiral - Piri Reis. The shocking fact is the way the map's detail mirrors the real Antarctic coast. This was 300 years before the continent's official discovery. In his map notes, the Admiral wrote that he drew it from numerous sources, some at least 3000 years old. (Image of Piri Reis map below)



But the most puzzling thing was the coastline of Antarctica, which is shown without its ice cover. The map provokes the imagination even today. Here's the verdict of a U.S. Air Force specialist:

“ The coastline was plotted on this map before it was covered in ice. The thickness of ice in this area is about One and a half kilometers. We do not have any suggestions how this data could have been obtained in 1513. ”

The international experts gave the Piri Reis map a thorough examination and concluded it was more precise than 20th century maps.

Seismic Analysis confirmed the fact, which scientists until recently, were unaware. Some of the mountains once considered a single massif, proved in reality to be separate islands; as stated on the old map.

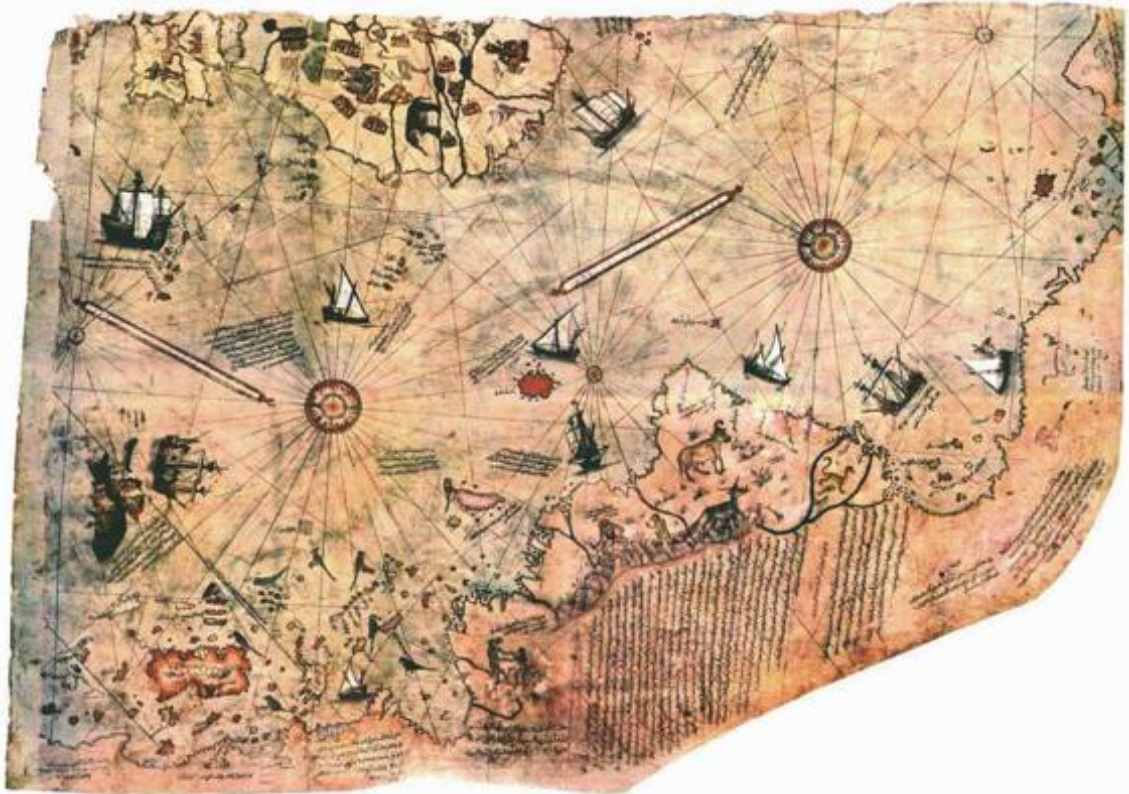

70 years ago, one can imagine the impact of the Piri Reis map on the founders of Aryan race theory. It brought hope to the search for the technomagical heritage of Atlantis. One hypothesis states that Antarctica is the former Atlantis; buried under the ice as a result of pole displacement. Once they knew these maps existed, they also realized secret knowledge could be stored elsewhere; but where...??

Ahnenerbe secret expeditions began the search for ancient relics and manuscripts around the world; from Tibet to South America. Notably they hunted for Knights Templar archives, which contain indications they visited America long before Columbus. Apparently, the Templars owned secret manuscripts, similar to the Piri Reis map. It suggests they knew something vital about Antarctica. In the occupied territories, SS special commando units, removed archives and libraries. The Ahnenerbe confiscated libraries of theological faculties and various secret societies, as soon as space was allocated.

b) Evacuating the Paranormal Library

The Ahnenerbe collected a huge library. According to the librarian from one of the Postonski libraries - in March of 1945, he witnessed Soviet troops approaching German territory. The Ahnenerbe were evacuating a library, carrying away 1,40,000 volumes. It's possible the Ahnenerbe learned something incredible about Antarctica. They made the study of this continent one of the main Nazi leadership goals.

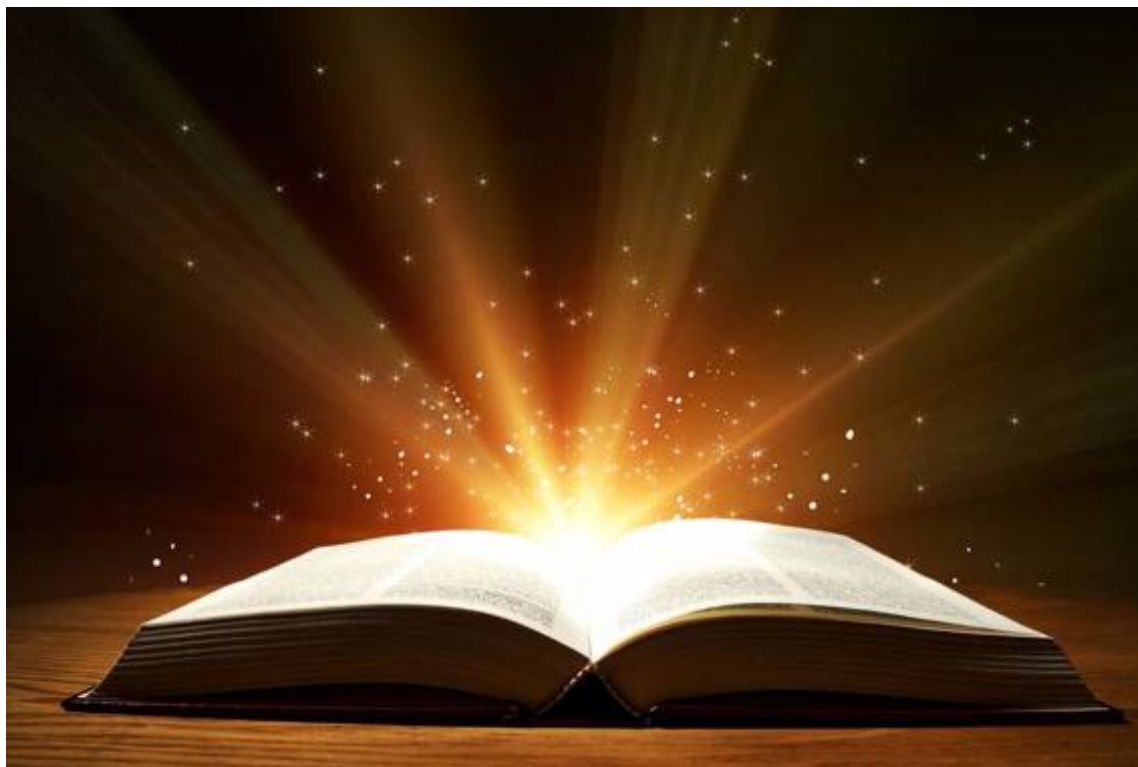

Actually, the SS were after very specific knowledge. To fuse the latest scientific achievements with centuries old knowledge; even in the absence of a rational explanation. It could have been an attractive and productive idea, if it wasn't for the purpose the Nazis pursued : - ' Supreme reign over the world, to enslave it for the chosen race utilizing occult knowledge and technology.' For scientific research, the Ahnenerbe employed elite staff: mainly world famous scientists and hundreds of employees from more than fifty university departments.

c) Paranormal Abilities

The Ahnenerbe engaged in the study of math, astronomy, genetics, medicine and the occult development of unconventional weapons. Plus psychological and psychotropic, methods of mass influence. They explored occult science, religious and mystical practices - exploring people's paranormal abilities.



The Ahnenerbe were seriously engaged in this research. The factual evidence for this are the Ahnenerbe directives by their management, which included Himmler, before the war began in 1939. Studies were carried out concerning the paranormal abilities of employees of the Ahnenerbe ; the results were recorded in personnel files. When the war started, officers with these paranormal abilities, along with others who displayed paranormal skills, were merged into a single Ahnenerbe department.

Unfortunately, there are no records on what this department was working on or more importantly what results were achieved. One of the main objectives pursued by the Ahnenerbe experts, was the use of paranormal abilities to contact unknown beings, or 'outsiders' as they called them. The aim was to obtain, from highly developed extraterrestrial, and ancient terrestrial civilizations their superior technological knowledge. It had already occurred.

3) The FLYING SAUCERS

December 1919, Secret 'Thule Society' members, (the Ahnenerbe's predecessor) are gathered at the Alps foothills, in a farmhouse near Berchtesgaden. Among the selected, were two experienced mediums, or contactees as we say today. One of them hides under the mysterious name of 'Sigrun'. The other is Maria Orsic from Zagreb. She speaks of strange things in a trance state. From a civilization in the Taurus constellation, she receives incredible technical information. This knowledge shocked no-one; on the contrary, it attracted huge interest, as it concerned the construction of an unusual flying vehicle, which could alter the flow of time around it. (Image below – 'the Die Glocke')

A step towards the dream of the secret society; a time machine penetrating deep into history. Obtaining the knowledge of ancient high civilizations.



This 'received knowledge' passes to scientists, for translation into clearer technical data for engineering. By 1922, the first model had been built. The device had three parallel discs. When brought into motion the upper and lower discs rotate in opposite directions, creating a very strong magnetic field and anti-gravity effect. If the evidence can be trusted, this

design not only floats in the air, but warps the structure of time around it. It is believed this was the prototype of future techno-magical flying saucers, based on non-classical flight principles. These super-discs were developed by a special technological unit of the SS, connected to the Ahnenerbe. Two basic ideas dominated the minds of senior management in Nazi Germany.

- First was the creation of a Super-Human.
- The Second, very important concept, was the mastery of techno-magic energies.

This not only included the possibility of mastering Nuclear Energy. But also of course - disc-shaped flying devices. For example: creating a fundamentally new type of flying technology.

The search for ideas went in all directions. It involved not only mediums and engineers but also historians. Even before the war, Ahnenerbe expeditions from Germany, returned with hundreds of ancient Sanskrit, Chinese and other oriental language parchments. They were studied very carefully. Wernher Von Braun the pioneering engineer and inventor in the fields of rocketry and space travel, later utters: “ We have learned a great deal for ourselves in these papers.”

Expedition results are reported to Hitler personally. Some of it inspired the Third Reich leader to such a degree, that thoughts of wonder weapons and space flight didn't leave him until the war's end. Designers try their best, but knowing rotation principles, and building anti-gravity super discs aren't enough. An appropriate engine is needed and they don't have it. The technology at the time was hopelessly behind these advanced ideas.

In July 1934, Hitler and the elite of the ‘ Thule ’ and ‘ Vril ’ secret societies invite the inventor Viktor Schauberger to work with them. His legendary ‘ implosion ’ engine is capable of producing light, heat and mechanical motion with only air and water. They needed one thing from him- to create an engine for flying discs. An agreement was reached, and after five years in 1939, a prototype of the ‘ Vril ’ disc with Schauberger's engine rose into the air. (Image of Viktor Schauberger below)



Progress with the techno-magical discs was extremely slow, with lack of experience and field specialists, they were forced to make extra-ordinary decisions. To develop the super disc ' Sonder Bureau 13 'was brought in. This special scientific research unit of the SS engaged in very delicate subjects, like the study of Unidentified Flying Objects. Even with top scientists and test pilots the project came to a standstill. Everything was top secret.

Valery Burdakov (Doctor of Technology, Developer of Space Technology) says – “ I spoke to German professor Hermann Oberth, counterpart to our Tsiolkovsky. He was the teacher of Wernher Von Braun and I asked him about flying saucers. He said, yes, I have heard of them, I have knowledge concerning them, the SS oversaw that, and we could not discover what our colleagues in Berlin was busy with.”

a) Vril-1/Jager/Haunebu I, II, III, IV

Burdakov continues “ At the end of 1942, a lightly armed flying disc took to the air, named the 'Vril 1' or 'Jager', with a diameter of 11.5 meters. It's alleged that before the war's end, 17 types of flying discs were made, but one should be skeptical of such claims. The chances are less that they had a whole collection of flying discs, may be a few copies, that's all. The Germans wanted to use them as spying devices. When you look side on, it's almost invisible.

The Generals who took part in the Battle of Kursk and two Soviet Union heroes I knew personally – a pilot and a tank commando, described to me what they saw: - a disc hung in the sky during the Kursk battle. What was it...?? They did not know. Neither the Germans nor Russians recognized it. The saucer wasn't made by us (Russia) I assure you, it's true, I know Russian aviation history, very well. Among the disc drawings and photos, is a saucer identified as the ‘ Haunebu ’. Data on the discs reads like science-fiction.” (Image of the Disc data below of the Haunebu I, II, III and IV)



According to descriptions, they used an alternative source of energy: the so-called converter of Hans Kohler, which required no fossil fuel. It was even planned to take the ' Haunebu – III ' disc type into space. Strange pilot suit found, suggests flights were scheduled to take place, if not in space then at least - the stratosphere.

In the seized archives, another mysterious document was discovered. It was a blueprint for a huge 139 meter long cigar shaped ship called 'Andromeda '. With hangars for five of the flying discs, of the ' Haunebu - II ' and ' Vril ' type. The purpose of this vehicle? Some believe it was designed for long term space flight.

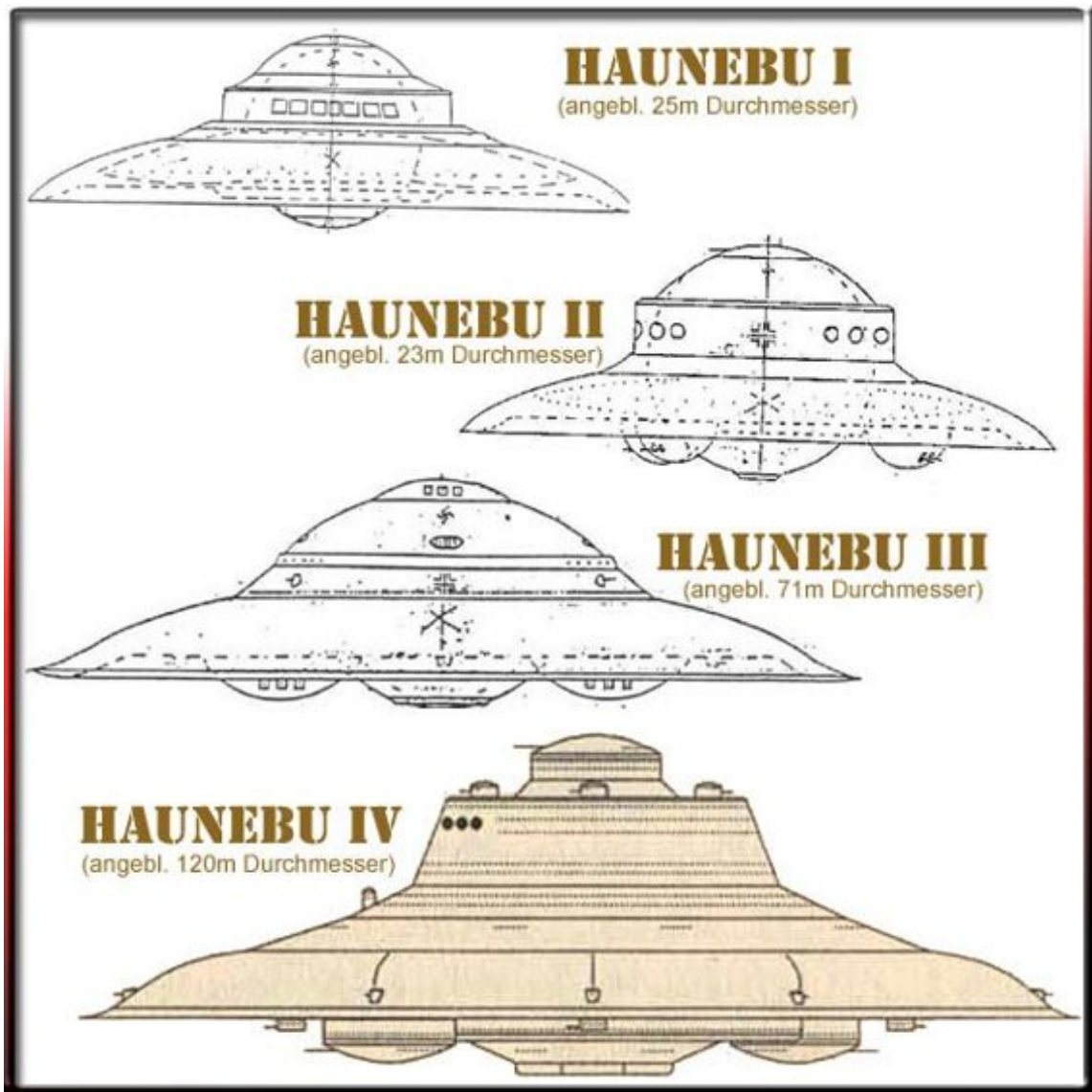

44 Geheim Kommandooffice

44

Flugkreisel-Erprobung. Stand / Anzahl Erprobungsflüge:

HAUNEBU I (vorhanden 2 Stück)	52	E-IV
HAUNEBU II (vorhanden 7 Stück)	106	E-IV
HAUNEBU III (vorhanden 1 Stück)	19	E-IV
(VRIL I) (vorhanden 17 Stück)	84	(Schwanz)

Empfehlung:

Beschleunigen von Abschlußerprobung
und Produktion „Haunebu II“
+ „VRIL I“

HAUNEBU I

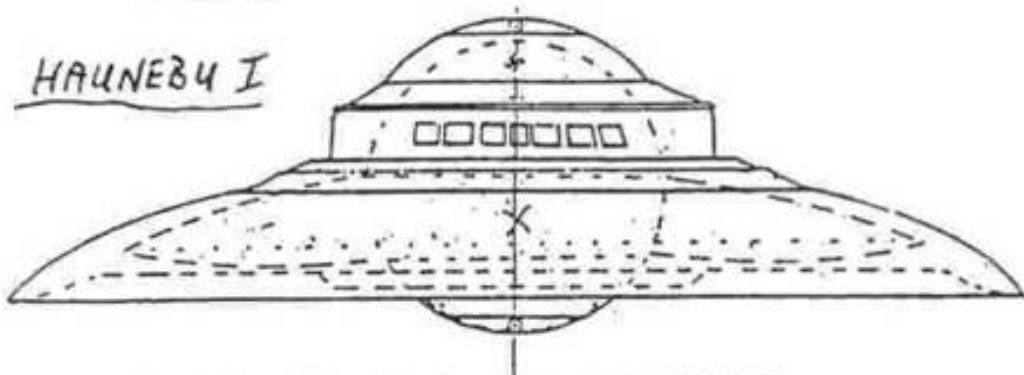

MITTELSCHWERER BEWAPNETER FLUGKREISEL. TYPE „HAUNEBU I“

Durchmesser: 25 Meter
Antrieb: Thule-Tachomotor 7b
Steuerung: Mag-Feld-Impulsler 4
Gesamtwiegezeit: 4800 Kilogramm p. Std. (rechts bis 17000)
Reichweite in Flugzeit: 18 Stunden
Bewaffnung: 2 x 8cm ESK in Drehtürmen und 4 x MK 108, starr nach vorn
Außenpanzerung: Doppel-Victrolax
Besatzung: 8 Mann
Weltallfähigkeit: 60 %
Stillschwebefähigkeit: 8 Minuten
Allgemeine Flugfähigkeit: Tag wie Nacht
Grundsätzliche Einsatztauglichkeit: 60 %
Frontverfügbarkeit: Nicht vor Jahresende 44

Bemerkung: Die SS-E-IV hält Konzentration auf bereits im Versuch stehende „Haunebu II“ für sinnvoller als an beiden Typen parallel weiterzuarbeiten. „Haunebu II“ verspricht entscheidende Verbesserungen in nahezu allen Punkten. Höhere Herstellungskosten schelisch gerechtfertigt - besonders mit Blick auf Führer-Sonderbefehl, Flugkreisel betreffend.

HAUNEBU II

7. November 1943
SS-Entwicklungsstelle IV

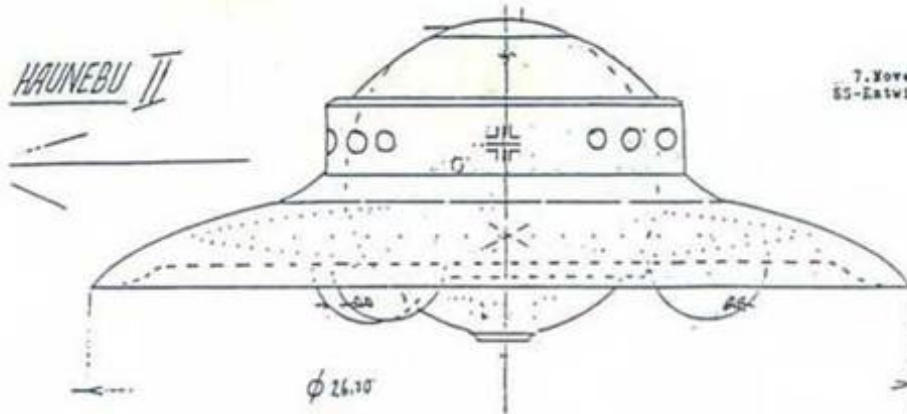

MITTELSCHWERER BEWAFFNETER FLUGKREISSEL, TYPE „HAUNEBU II“

Durchmesser: 26,1 Meter
Antrieb: „Thule“-Tachomotor 70 (gepanzert; ϕ 27.-Scheibe; 25,1 Meter)
Steuerung: Mag-Feld-Impulsor 4a
Geschwindigkeit: 6000 Kilometer p. Stunde (rechnerisch bis ca. 21000 möglich)
Reichweite (in Flugdauer): ca. 55 Stunden
Bewaffnung: 6 8 cm KSK in drei Drehtürmen, unten, eine 11 cm KSK in einem Drehturm, oben
Außenpanzerung: Dreischicht-„Vistales“
Besatzung: 9 Mann (erg. Transportverm. bis zu 20 Mann)
Weltallfähigkeit: 100 %
Stillschwebefähigkeit: 17 Minuten
Allgemeines Flugvermögen: Tag und Nacht, witterungsabhängig
Grundsätzliche Einsatztauglichkeit (77): 85,5

Verfügbarkeit „Haunebu II“ (bei weiterem Erprobungsverlauf wie 77) ab Oktober.
Dass Serienherstellung ab Jahresende 1943/44, jedoch noch ohne verbesserte Kraftstrahl-
kanone „Döner-Iek III“, deren Prototypen nicht vor Frühjahr 1944 angenommen werden
kann.

Von Führer verlangte hundertprozentige Einsatzreife rundum kann allerdings
nicht vor Ende nächsten Jahres erwartet werden. Erst ab etwa Serie 9.

Begerkung zuständige SS-Entwicklungsstelle IV: Die neue deutsche Technik- und
damit vor allem Flugkreisel und KSK wird wegen der noch zeitraubenden Material-

HAUNEBU III

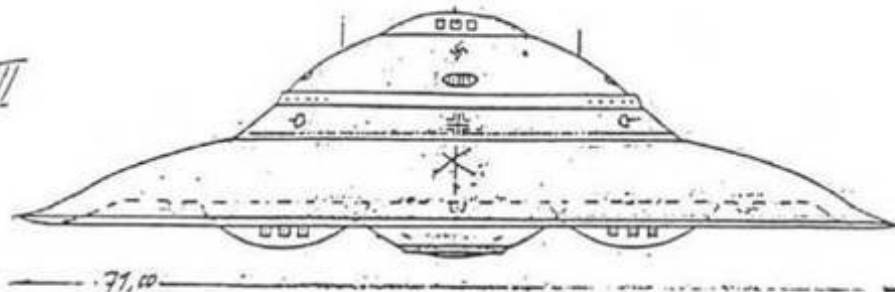

SCHWERER BEWAFFNETER FLUGKREISSEL „HAUNEBU III“

Durchmesser: 71 Meter
Antrieb: Thule-Tachomotor 70 plus Schumann-Levitatoren (gepanzert)
Steuerung: Mag-Feld-Impulsor 4a
Geschwindigkeit: ca. 7000 Kilom. p. Stunde (rechnerisch bis zu 40000)
Reichweite (in Flugdauer): ca. 8 Wochen (bei S-L-Flug 40% mehr)
Bewaffnung: 4 x 11cm KSK in Drehtürmen (3 unten, 1 oben), 10 x 8cm KSK
in Drehtürmen plus 6 x MK 108, 8 x 3cm KSK ferngesteuert
Außenpanzerung: Dreischicht-„Vistales“
Besatzung: 32 Mann (erg. Transportverm. max. 70 Personen)
Weltallfähigkeit: 100 %
Stillschwebefähigkeit: 25 Minuten
Allgemeines Flugvermögen: witterungsabhängig Tag und Nacht
Grundsätzliche Einsatztauglichkeit: Etwa 1945

Bemerkung: SS-X-IV hält den Hinweis für notwendig, daß in
„Haunebu III“ ein großartiges Werk deutscher Technik im ent-
stehen ist, wegen der allgemeinen Materiallage aber alle
Erfolge auf dem schneller verfügbaren Haunebu II gesetzt
werden sollten.

Gemeinsam mit dem leichten Flugkreisel „Vril“ der Schumann-
Gruppe könnte „Haunebu II“ die von Führer aufgestellten
Forderungen sicherlich erfüllen.

There's another simpler explanation, that it was a project for an underwater container. Which could be used to transport goods, equipment, technology, etc... for the secret bases of the Third Reich, including the Antarctic. According to American intelligence, by the war's end, the Germans had 9 research enterprises developing and testing flying discs. Investigations revealed that 8 of these factories, along with scientists and key figures were successfully evacuated from Germany and the ninth one was destroyed.

Air Force Lieutenant Colonel Wendelle Stevens, recalls: “ We had classified information that some of these research enterprises were transported to Antarctica - to the place called New Swabia. At least one disc research company was transported to that location. Another went to the Amazon and a third to the north coast of Norway. They were evacuated to secret underground facilities.”

But the Third Reich didn't have enough time to implement this grandiose plan. It seems that by the war's end, techno-magical disc development never reached the industrial production stage. The discs encountered in Antarctica in 1947 were probably not the same discs. Perhaps they were German discs, flying on classical principles. Ones that had already been developed by the Third Reich, perhaps as a fall back to their techno-magical projects. A few such prototypes had already been made, some proved themselves well. It was a giant technological leap, and Germany's opponents weren't even close. But far from the kind of flying discs, that the Reich leaders had in mind. ”

b) Bellonzo

One of the most advanced prototypes, the so-called ' Bellonzo ' flying disc was tested for the first and last time, on February 14th , 1945 near Prague. The lift power was created by the silent flameless engine of Viktor Schauberg. Reports say, the unpiloted disc reached a height of 15 kilometers in 3 minutes. With a horizontal speed of 2200 kilo meters per hour. The flying disc proved it can hang in the air, and fly back and forth without reversing. A success..?? – Absolutely. (A Graphical Replica of Bellonzo below)



But war was now on German territory. Not waiting for German territorial occupation, the Nazis destroyed any non-conventional prototypes they couldn't evacuate. The only example of the ' Bellonzo ' disc was also destroyed.

The developer of its main engine -Viktor Schauberg later recalled: “ The model tested in February 1945, was built in collaboration with world

class combustion engineer experts from Mauthausen concentration camp. Then they were returned to the camp, for them this was the end. It was Keitel who had the disc prototype blown up. ”

(Below find paper scans of the actual Bellonzo modal)

The Miethe-Belluzzo Disc--Designs Two And Three

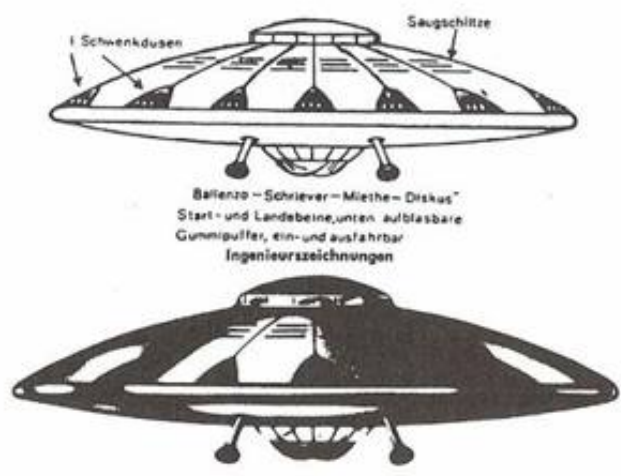
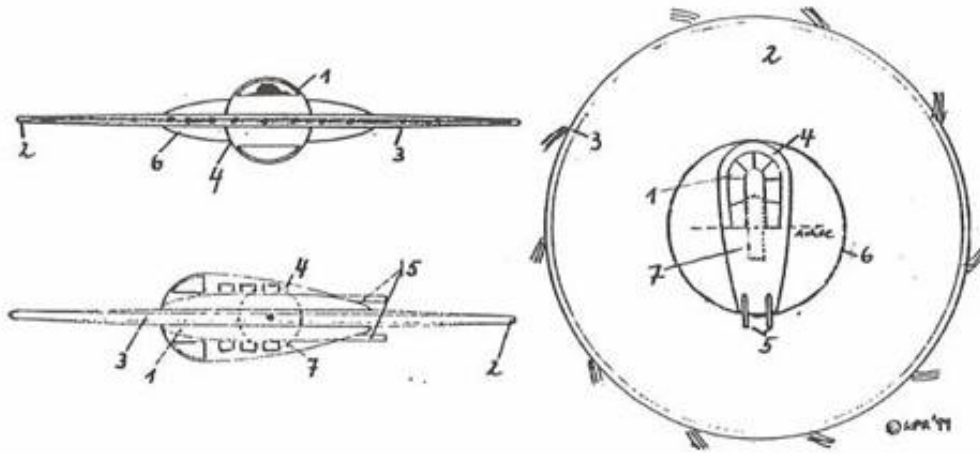

On the top is Miethe-Belluzzo design two. Note rotating disc (2) and stabilizing wheel (7) acting as a gyroscope. (Courtesy of Klaus-Peter Rothkugel)

On the bottom is Miethe-Belluzzo design three, capable of vertical take-off.

It's vital to credit the German scientists and engineers, who achieved huge successes. The Third Reich's huge leap in science and technology wasn't accidental. Combining scientific research, with an analysis of ancient knowledge brought incredible results. However the defeat the Nazis suffered was not accidental.

Many legends and rumors are associated with the discs of the Third Reich. In addition to these stories, there are also tales of German discs flying out of Antarctic waters in 1947, regarding the saucers that emerged from the water, witnessed in the 1940s and nowadays, the recorded sightings of flights of Unidentified Flying Objects (U.F.O) emerging from seas, oceans, lakes, etc. Most probably in 1947, the Germans could not have had such technology and neither could any country in the world. But if the Germans did not attack the American expedition in 1947.....Who did...??

4) THE ANTARCTIC PORTAL

Emerging out of the water; shining saucers, spheres, cigar-like objects, in the polar and surrounding areas are not unusual facts. The northern countries, Central and South America, Australia, South Africa – everywhere, unidentified flying objects are observed. Reports on them were regularly received by USSR Navy intelligence.

a) U.F.O Sightings

According to Victor Berezhev (1st Rank Captain, Veteran of Soviet Navy Intelligence) they regularly received reports on such objects detected by witnesses. It would be incorrect to think that unidentified flying objects were only observed in the north. They were also observed across the Atlantic, even in the South Atlantic, near Antarctica.

One particular case was where they were observed in the area of the islands of South Georgia. Emerging from beneath the waters, fishermen saw an object. They managed to take a photograph. (shown below). Despite the strong wind, the object remained static for a long time, clearly it wasn't a cloud.



Over the islands of South Georgia very strange flying objects were observed. Here's the evidence from one case. (image below)

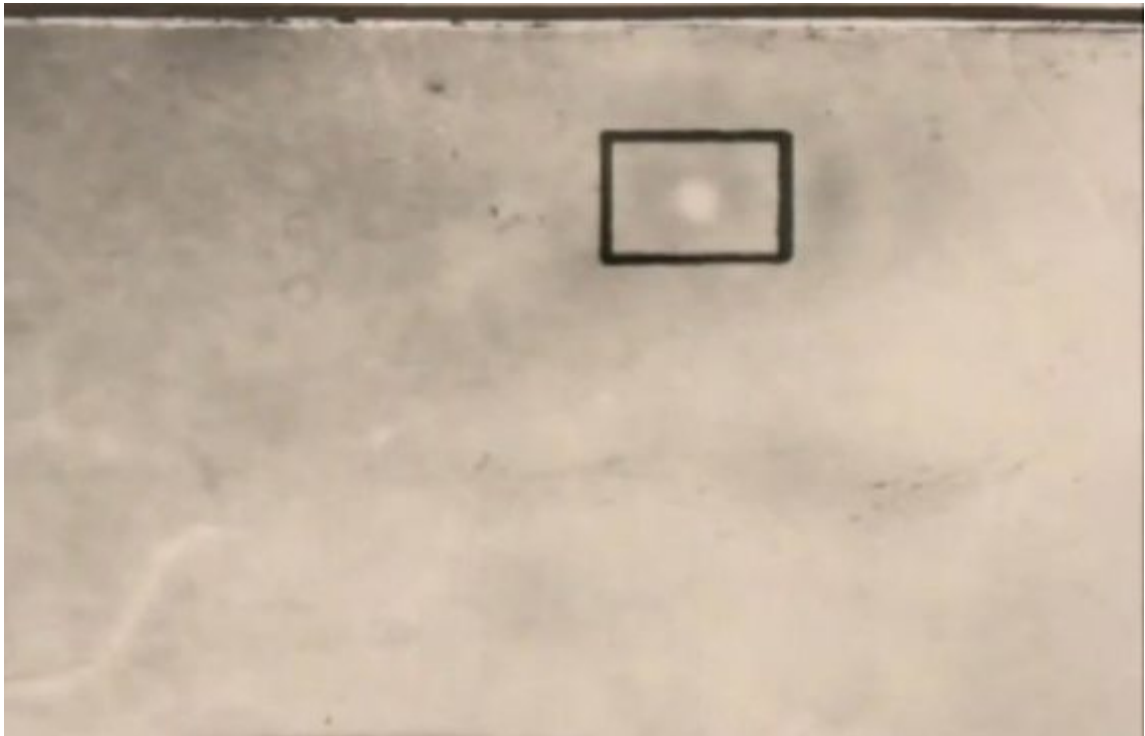

This disc hung over the island and was visible for a long time during daylight, just before sunset and just after sunset, for around one and a half to two hours. The object had a symmetrical circular shape and with-in it was visible isosceles triangle. At night the triangle not only shined, but lights were observed at the base of the two corners as if the object had a working engine. However the object remained in the same spot all the time. Observation of this object occurred in 1979.

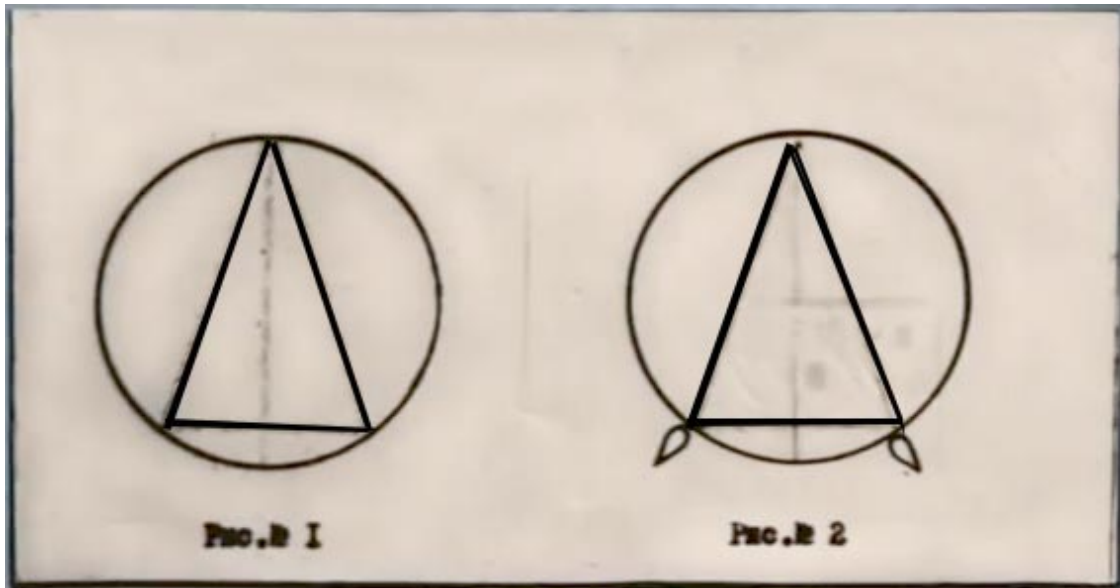

Three years before in 1976, Japanese researchers using the latest equipment detected 19 round objects, which dived from space into Antarctica and disappeared from the screens. Who were they and where did they go..?? We have now answers to such questions.

b) Wormholes and Black holes

In the late eighties, a scientific sensation was created by American astrophysicist Kip Thorne and his colleagues work. They substantiated the possibility of nearly instantaneous movement in space and time travel. They put forward the idea of wormholes and black holes all extremely intriguing. According to which black holes are located at close distances to our planet and take the form of these worm holes. These wormholes can be used for intergalactic and interstellar travel. Other scientists suggest their work has significant practical characteristics. Specifically, building time travel devices: ensuring intergalactic travel.

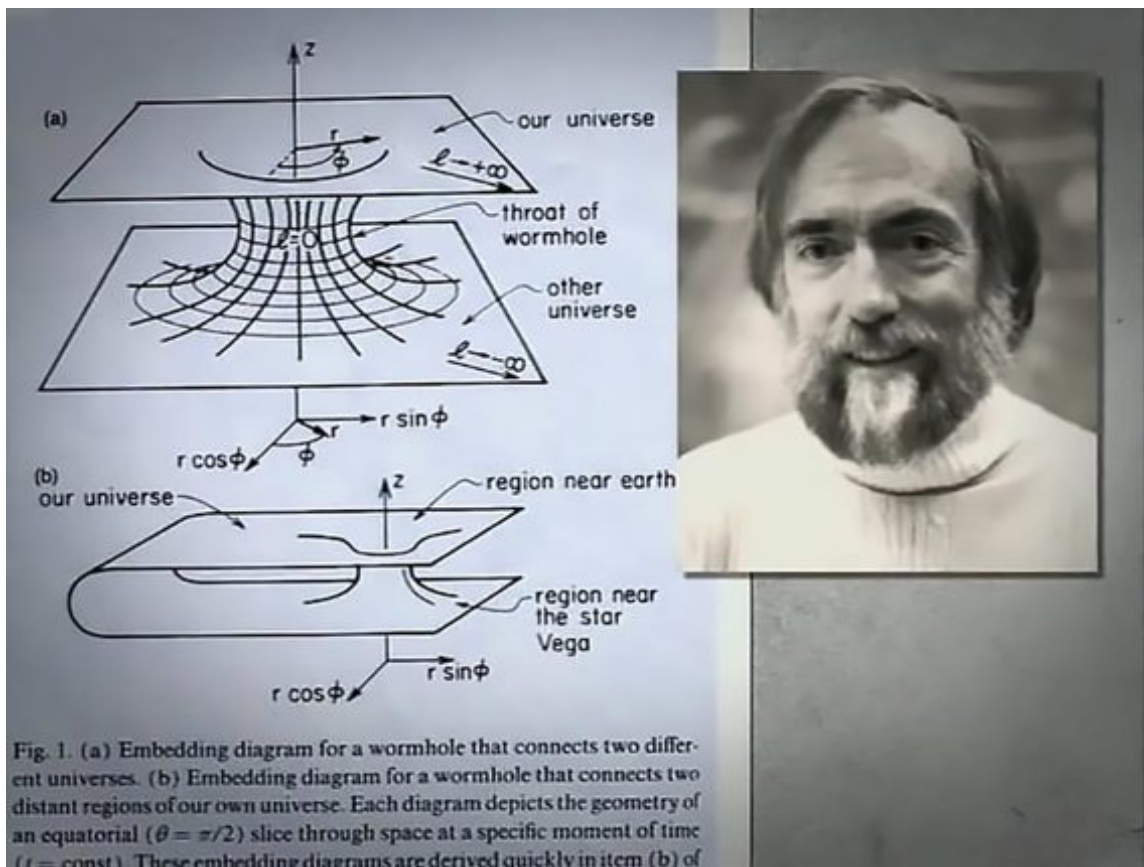

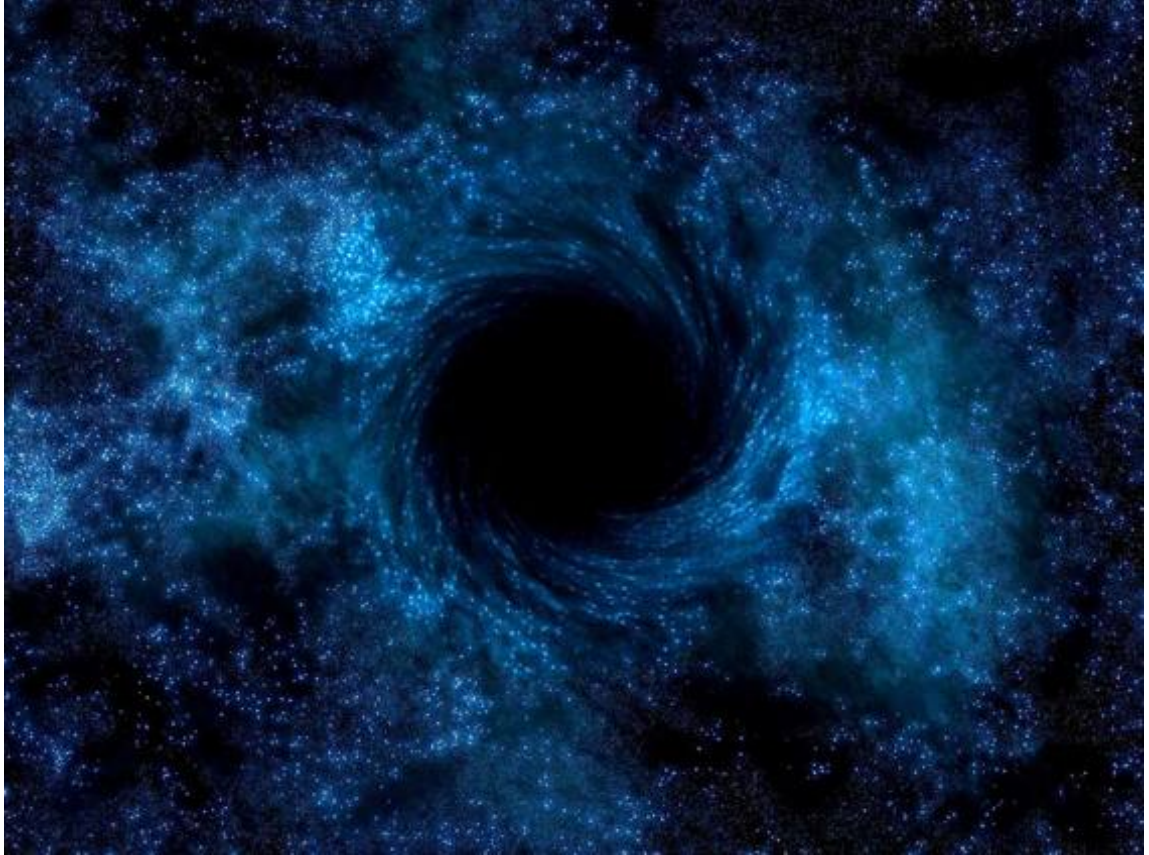

Kip Thorne concluded that near to Earth, there's an entrance into a worm hole leading to the star Vega. At that time, without a doubt, the Americans already knew very well, the way in which the appearance and disappearance of UFOs takes place, in the atmosphere of our planet.

c) HAARP (The REAL and MYSTERIOUS Reason behind)

In 1992, construction began in Alaska, of a powerful radio-electronic complex called HAARP. Officially, it was to study the ionosphere and the development of missile defense systems. Clandestinely, it was to develop new weapon types: geophysical, weather and psychotropic. In essence a massive beam cannon, a type of global microwave oven. In addition to this there was something else. Today, we can safely assume that the main purpose of this station, is the search for the entrance to the wormhole.



Which means the Americans came to the conclusion, that in this polar region, the entrance to the wormhole is located. The station's radio waves allow it to determine the wormhole's configuration, then trace it back, and find where the entrance and exit is.

In 1998, the complex in Alaska was put into action. An identical transmitter is built in Norway. On its way, is a third, more powerful one in Greenland. In the early nineties technical capabilities made it possible to focus only on one site; the Alaska portal as an entrance and exit, to observe the movement of UFO's on our planet. There was no need to install tracking stations across United States territory or other territories, control of just one portal was enough.

However Earth has two poles. What is the role of each in terms of this theory? Well, for example, they use it both for entry and exit through Alaska, or use the portal to enter and leave Antarctica, and vice versa.

Through Antarctica the UFO emerges into the atmosphere of our planet, and through Alaska the north portal they leave the planet. The theory of ' Tunnel Effects ', does not contradict the fact that the North pole of our Earth is the entrance, and the South pole of the Earth is an outlet, that links our planet with other planets and stars, on the level of energetic-information.



It's possible our poles properties are used by unidentified flying objects to communicate with other parts of the Universe. In any case, it should be a subject for serious study.

It's no surprise concerning the well-known fact, namely most of the staff on the American Antarctic stations are personnel of the United States

National Security Agency. Employees of American military, technical intelligence, electronic intelligence and Central Intelligence Agency employees. These categories represent the main research personnel on American Antarctic stations.

Perhaps the scientists of the Third Reich also inferred, the Arctic and Antarctica were not just Earth poles. Perhaps it's also no coincidence that in Nazi Germany, the hollow Earth theory, where the poles were presented as gates to the stars was so popular.

Perhaps at this bizarre idea's heart, a vague understanding was reached, something akin to recently discovered wormholes. Along with the possibility of space and time travel, this may be why Antarctica attracted Germans to its shores.

The sixth continent continues to keep its secrets. New questions are raised, and over the years, this list hasn't got any smaller. What happened to the research to build flying saucers? Did it stop after the war, or continue in secret places around the globe?. Is it correct to attribute modern secret developments to all U.F.O sightings..??

U.F.Os were observed long ago, even during the time of Alexander of Macedon. What kind of objects emerged from the water, attacking Admiral Byrd's expedition? Great unknown beings, whom the Germans strove passionately to cooperate with? What is it...??? ' Myth ' or real life existing forces that for thousands of years have conducted their invisible activities on our planet Earth?

5) THANK YOU...!!!

Hope you enjoyed the Book and also along realized that there is much more to this World what we live in, than what we have seen and experienced. And it's bizarre to think- we are the only fish in this humongous wide ocean called " UNIVERSE ".

Table of Contents

INTRODUCTION

- 1) Operation ' HIGH JUMP ' to ANTARCTIC
- 2) AHNENERBE SOCIETY of the Third Reich (The BIGGEST and Most MYSTERIOUS OCCULT Organization in History with Govt. Funding and Support)
 - a) The Piri Reis Map (the Map which stunned Modern Explorers and Scientists)
 - b) Evacuating the Paranormal Library
- c) Paranormal Abilities
- 3) The FLYING SAUCERS
 - a) Vril-1/Jager/Haunebu I, II, III, IV
 - b) Bellonzo
- 4) THE ANTARCTIC PORTAL
 - a) U.F.O Sightings
 - b) Wormholes and Black holes
 - c) HAARP (The REAL and MYSTERIOUS Reason behind)
- 5) THANK YOU...!!!